

BE 3251 - BASIC ELECTRICAL AND ELECTRONICS ENGINEERING.

UNIT-1. ELECTRICAL CIRCUITS :-

DC CIRCUITS :-

CIRCUIT COMPONENTS :-

Conductors :-

* Continuous flow of electrons through a medium constitutes an electric current.

* The substances which allows the electric current to pass through it are known as CONDUCTORS.

The three basic circuit components are

- ① Resistor
- ② Inductor
- ③ Capacitor.

RESISTOR :-

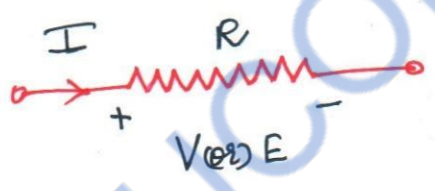

Resistor is an electrical component made from the material which opposes the flow of current through it.

* It is denoted by "R"

* The unit of Resistance is Ohm (Ω)

* The relation between voltage and current is given by

OHM'S LAW.

OHM'S LAW :-

When the temperature remains constant, the current flowing through a conductor is directly proportional to the potential difference across the conductor.

$E \propto I$ (At const temperature) \Rightarrow $E = IR$, where 'R' is constant of proportionality.

$$\boxed{E = IR} \quad (\text{or}) \quad \boxed{V = IR}$$

$E \Rightarrow$ Potential difference in Volts

$I \Rightarrow$ Current in amperes.

* Energy is dissipated in the resistor in the form of heat.

It is given by

$$P = VI = (IR)(I) = I^2R = \frac{V^2}{R} \cdot R = \frac{V^2}{R}$$

$$\boxed{P = \frac{V^2}{R} \text{ Watts}}$$

INDUCTOR:-

Inductor is an element in which energy can be stored in the form of Electromagnetic field.

* It is denoted by "L"

* Unit is Henry (H)



CAPACITOR:-

Capacitor is a storage element which can store and deliver energy in an electric field.

* It is denoted by "C"

* Unit is Farad (F).



OHM'S LAW:-

When voltage is applied to a closed circuit, it causes a flow of electrons and consequently there exists current in the circuit.

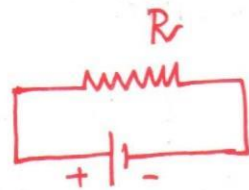

The resistance of the circuit opposes this current flow.

Ohm's Law states that

When the temperature remains constant, the current flowing through a conductor is directly proportional to the potential difference across the conductor.

$$V \propto I$$

$$V = IR$$

Where 'R' \Rightarrow Proportionality Constant

V \Rightarrow Voltage in volt.

I \Rightarrow Current in ampere.

Limitations :-

- \Rightarrow Ohm's law does not apply to all the non-metallic conductors
- \Rightarrow It is not applicable to non-linear devices such as Zener Diode, vacuum tubes etc.
- \Rightarrow Ohm's law is true for metal conductors at constant temperature.

(*) If the temperature changes, the law is not applicable.

KIRCHHOFF'S LAW:-

Law 1 :- KIRCHHOFF'S CURRENT LAW

Law 2 :- KIRCHHOFF'S VOLTAGE LAW.

KIRCHHOFF'S CURRENT LAW :- (LAW 1)

The sum of the currents flowing towards a junction is equal to the sum of the currents flowing away from the junction.

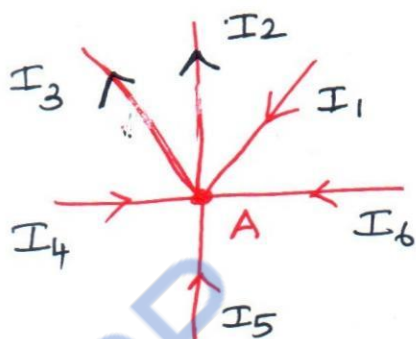

A → Junction

According to Kirchhoff's current law,

$$I_1 + I_4 + I_5 + I_6 = I_2 + I_3$$

Current flowing towards junction "A"

Current flowing away from junction "A"

The current at node "A" is equal to zero.

KIRCHHOFF'S VOLTAGE LAW :- (LAW 2)

In a closed circuit, the sum of the potential drops is equal to the sum of the potential rises.

* ABCDA form a closed circuit

Sum of potential drops

$$= IR_1 + IR_2 + IR_3 \rightarrow \textcircled{1}$$

$$\text{Potential rise from D to A} = V \rightarrow \textcircled{2}$$

Equating $\textcircled{1}$ & $\textcircled{2}$ Equations

$$V = IR_1 + IR_2 + IR_3$$

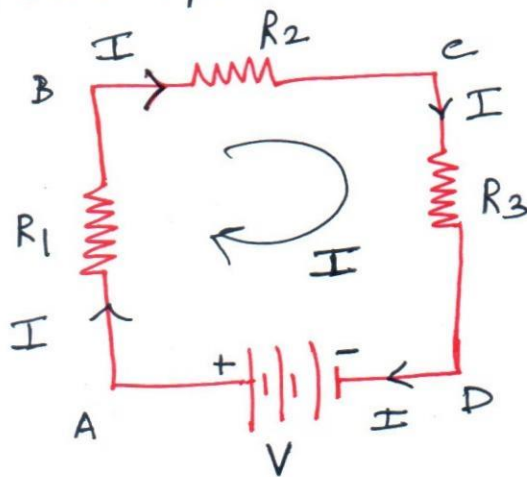

NETWORK DEFINITIONS:-

NETWORK :-

Any arrangement of the various electrical energy sources along with different circuit elements is called an ELECTRICAL NETWORK.

NETWORK ELEMENT:-

Any individual circuit element with two terminals which can be connected to other circuit element is called as NETWORK ELEMENT.

NETWORK ELEMENTS

ACTIVE ELEMENTS

PASSIVE ELEMENTS

Eg:- Voltage sources
Current sources

Eg:- Resistors
Capacitors
Inductors.

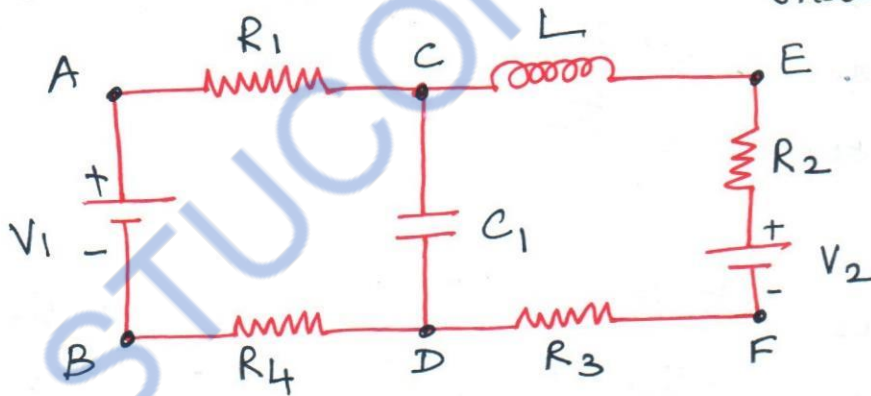

BRANCH :-

Figure (a).

A part of the network which connects the various points of the network with one another is called a BRANCH.

In the figure (a)

A-C, C-E, E-F, F-D, D-B, B-A, C-D are called the branches of the network.

JUNCTION POINT:-

A point where three or more branches meet is called a JUNCTION POINT.

The Junction points are 'C' and 'D'.

NODE:-

A point at which two or more elements are joined together is called NODE.

The junction points are also the nodes of the network. In the figure @ A, B, C, D, E and F are the nodes.

LOOP:-

LOOP is a set of branches forming a closed path in a network.

In the figure @, paths ACDBA, ACEFDBA, CEFDC are the loops of the network.

MESH:-

MESH is a set of branches forming a closed path in a network with no other paths inside it.

In the figure @ paths ACDBA, CEFDC are the meshes of the network.

ENERGY SOURCES:-

Energy sources are devices which supply

Electric Energy.

INDEPENDENT SOURCES :-

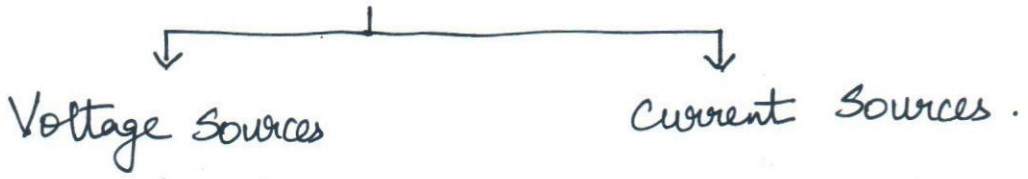

VOLTAGE SOURCES

(I) Ideal voltage source

* It is the source which delivers energy with specified terminal voltage, which is independent of the current supplied by the source.

* For Ideal voltage source, the internal resistance (or) Impedance is zero.

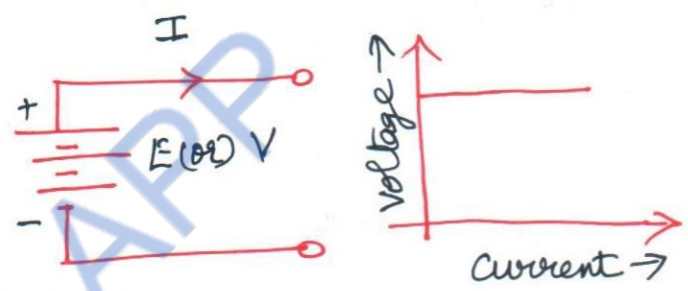

(II) Practical voltage source.

The terminal voltage falls with increase in the current supplied by the source.

(-X) The voltage is dependent on the current supplied by the source.

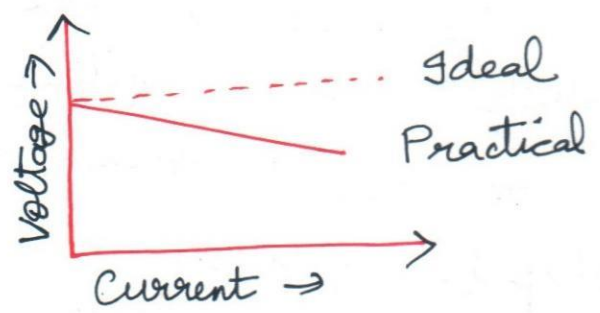
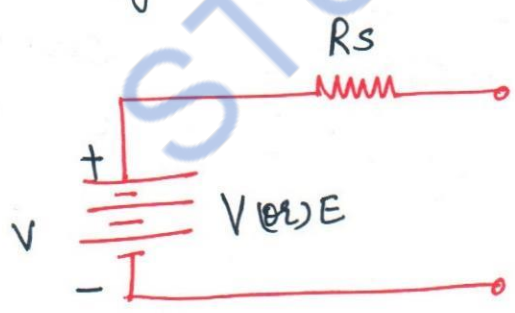

CURRENT SOURCES :-

Ideal current source:-

It is a source which delivers energy with a specified current, which is independent of the voltage at its terminals.

The internal Impedance (or Resistance) of an Ideal Current Source is Zero

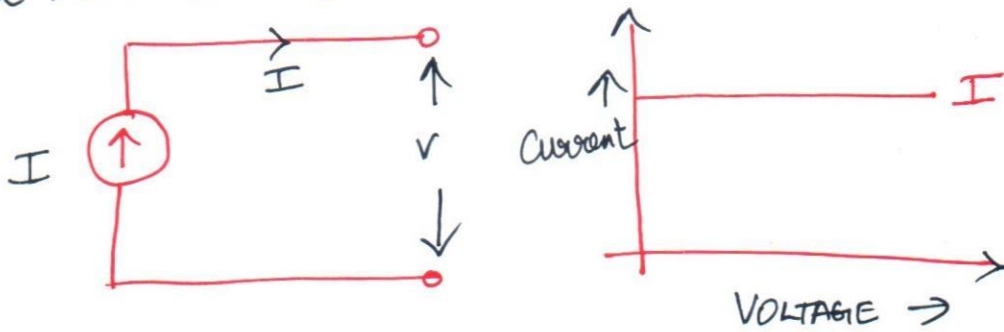

PRACTICAL CURRENT SOURCE

⇒ It is represented by the current source 'I' in parallel with Internal Impedance (or Resistance).

* In a practical current source, current supplied by the source is decreased with increase in voltage.

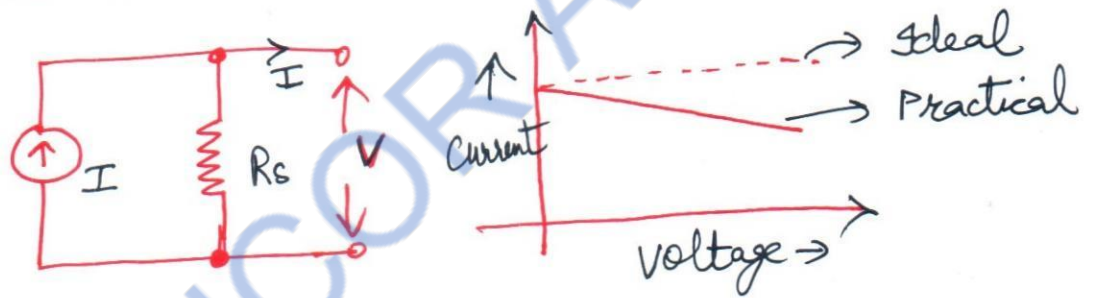

DEPENDENT SOURCES:-

→ Depends on some other quantity in the circuit which may be either a voltage or a current.

* Such a source is represented by a diamond shaped symbol.

FOUR TYPES OF DEPENDENT SOURCES.

- ① Voltage Dependent Voltage source
- ② Current Dependent Voltage source
- ③ Voltage Dependent Current source
- ④ Current Dependent Current source.

Voltage Dependent voltage source

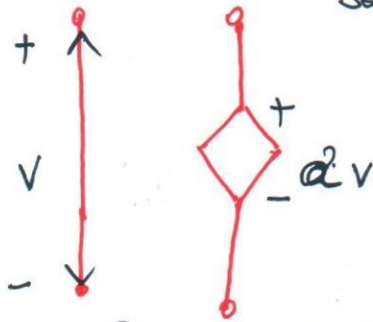

Current Dependent voltage source (5)

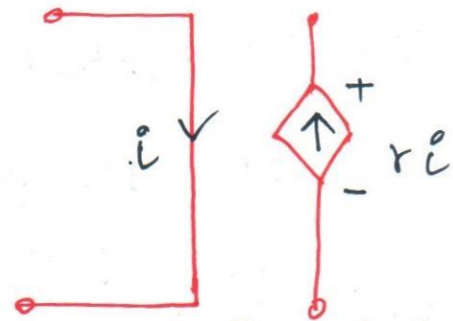

Voltage Dependent current source

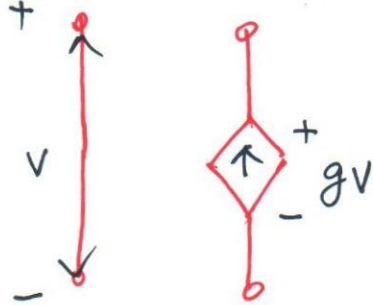

Current Dependent current source

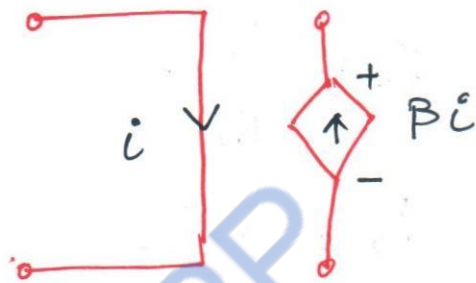

RESISTORS IN SERIES:-

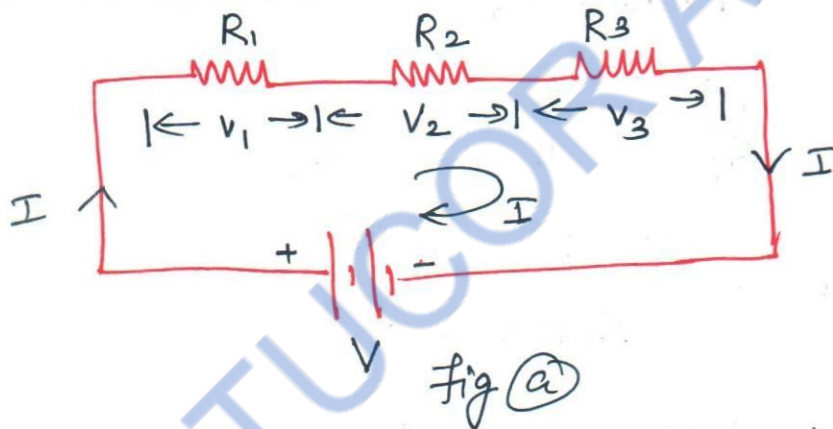

→ When the Resistors are connected such that the same current passes through all of them, then it is said that the Resistors are connected in series.

Each Resistor has a voltage drop across it

$$V_1 = IR_1 \rightarrow \textcircled{1}$$

$$V_2 = IR_2 \rightarrow \textcircled{2}$$

$$V_3 = IR_3 \rightarrow \textcircled{3}$$

The total drop in the three resistors put together is

$$V = V_1 + V_2 + V_3$$

$$V = IR_1 + IR_2 + IR_3$$

$$V = I[R_1 + R_2 + R_3]$$

In the circuit, the power dissipated in 'R₁' is given as

$$P_1 = I^2 R_1 = \frac{V_1^2}{R_1} \times R_1 \Rightarrow \frac{V_1^2}{R_1}$$

Similarly,

$$P_2 = \frac{V_2^2}{R_2}$$

$$P_3 = \frac{V_3^2}{R_3}$$

Total power $P = P_1 + P_2 + P_3$

$$P = \frac{V_1^2}{R_1} + \frac{V_2^2}{R_2} + \frac{V_3^2}{R_3}$$

$$P = \frac{V_1^2 + V_2^2 + V_3^2}{R_1 + R_2 + R_3}$$

$$P = \frac{V^2}{R_{\text{eff}}} = VI$$

$$R_{\text{eff}} = R_1 + R_2 + R_3$$

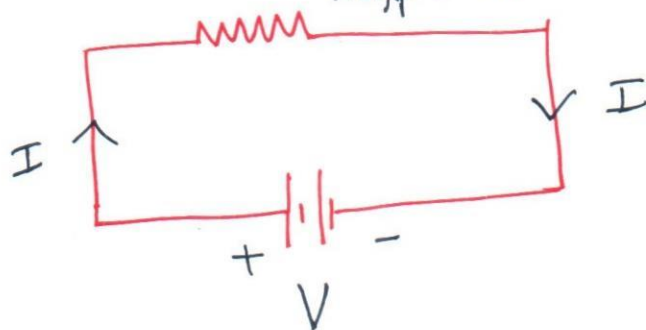

In series circuit,

- ⇒ Same current flows through all the resistors.
- ⇒ For each resistor, there will be voltage drop according to OHM's Law.
- ⇒ The sum of the voltage drop = Applied voltage

DIVISION OF VOLTAGE IN SERIES CIRCUIT:-

Let two resistors R_1 and R_2 are in series connected to a DC source of voltage " V ".

' I ' is the current flowing through the resistor R_1 & R_2 .
' V_1 ' and ' V_2 ' are the voltage drop across ' R_1 ' & ' R_2 ' respectively

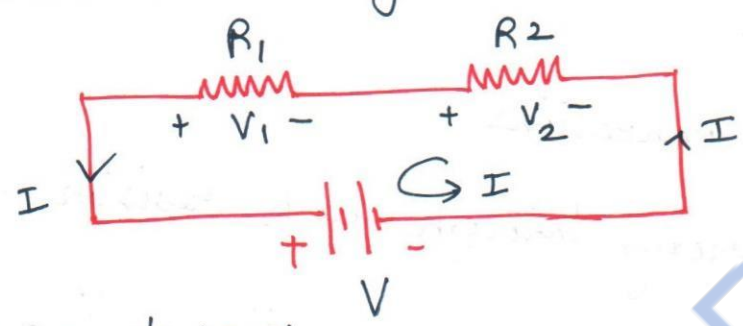

By applying OHM'S LAW:-

$$V_1 = IR_1 \rightarrow \textcircled{1}$$

$$V_2 = IR_2 \rightarrow \textcircled{2}$$

Applying KVL we get

$$V = V_1 + V_2 \Rightarrow IR_1 + IR_2 \Rightarrow I(R_1 + R_2)$$

$$\Rightarrow I = \frac{V}{R_1 + R_2}$$

To find $V_1 \Rightarrow$ Total Voltage

$$V_1 = V \times \frac{R_1}{R_1 + R_2} \quad \text{(Voltage divider rule)}$$

(Total Resistance)

$$V_2 = V \times \frac{R_2}{R_1 + R_2} \quad \text{(same Resistance)}$$

$$V_1 = V \times \frac{R_1}{R_1 + R_2}, \quad V_2 = V \times \frac{R_2}{R_1 + R_2}$$

[voltage divider rule Equations]

RESISTORS IN PARALLEL:-

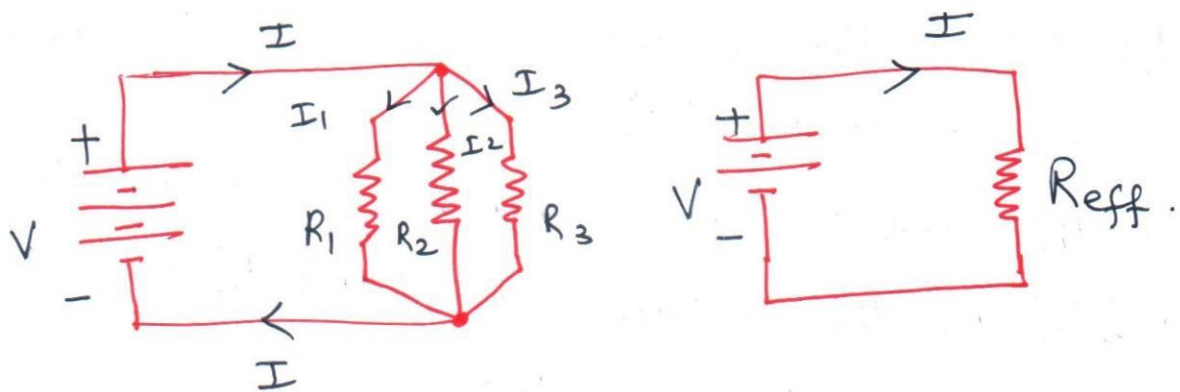

In parallel connections

(*) * Current flowing through each resistor is different

$$I_1 = \frac{V}{R_1}, \quad I_2 = \frac{V}{R_2}, \quad I_3 = \frac{V}{R_3}$$

* Voltage across the terminals in parallel connection is SAME

$$I = I_1 + I_2 + I_3 \Rightarrow \frac{V}{R_1} + \frac{V}{R_2} + \frac{V}{R_3}$$

$$I = V \left[\frac{1}{R_1} + \frac{1}{R_2} + \frac{1}{R_3} \right]$$

$$\therefore \frac{1}{R_{\text{eff}}} = \frac{1}{R_1} + \frac{1}{R_2} + \frac{1}{R_3}$$

For '2' Resistors

$$\frac{1}{R_{\text{eff}}} = \frac{1}{R_1} + \frac{1}{R_2} \Rightarrow$$

$$\frac{1}{R_{\text{eff}}} = \frac{R_1 + R_2}{R_1 R_2}$$

(*) \Rightarrow $R_{\text{eff}} = \frac{R_1 R_2}{R_1 + R_2}$

In a parallel circuit

(7)

- ⇒ Voltage across each resistor is same
- ⇒ Current in each branch is given by OHM'S LAW
- ⇒ Total current = Sum of the branch currents.

DIVISION OF CURRENT IN PARALLEL CIRCUIT:-

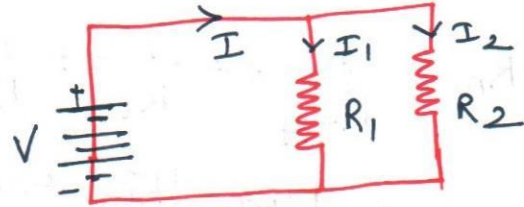

$$\text{Current } I = I_1 + I_2$$

$$\text{Voltage } V = I_1 R_1 = I_2 R_2$$

$$\text{To find } I_1 = I (\text{Total current}) \times \frac{R_2 (\text{Other Resistance})}{R_1 + R_2}$$

$$I_2 = I (\text{Total current}) \times \frac{R_1 (\text{Other Resistance})}{R_1 + R_2}$$

Difference between Series & Parallel Circuit.

Series circuit

1. The total effective resistance is the sum of the individual resistances

$$R_{\text{eff}} = R_1 + R_2 + R_3 \dots + R_n$$

2. Only one path for the current flow
3. The current flowing through all the resistor will be same and equal to the total current
4. The voltage is divided across each resistor according to the value of resistance.
5. The Input voltage is equal to the sum of the voltage drop in individual resistances

$$V = V_1 + V_2 + \dots + V_n$$

Parallel circuit

1. The reciprocal of the total effective resistance is the sum of the reciprocals of the individual Resistances

$$\frac{1}{R_{\text{eff}}} = \frac{1}{R_1} + \frac{1}{R_2} + \dots + \frac{1}{R_n}$$

2. More than one path for the current flow.
3. The current flowing through each resistance is different.
4. The voltage across each resistor is same which will be equal to the Input voltage
5. The total current is the sum of currents flowing through various resistances connected in parallel

$$I = I_1 + I_2 + \dots + I_n$$

INTRODUCTION TO AC CIRCUITS:

20

The voltage changes not only in magnitude but also in direction (or) time.

Sinusoidal voltage and current Equations:

$$e = E_m \sin \omega t \quad (\text{or}) \quad v = V_m \sin \omega t \quad \text{and}$$

$$i = I_m \sin \omega t$$

Where e (or) v are instantaneous values

E_m , V_m & I_m are peak values.

$\omega \Rightarrow$ Angular frequency in radians/second.

Problems:

1. The period of a sine wave is 20ms. What is its frequency? Represent the sine wave

Solution

$$\text{Frequency } f = \frac{1}{T}$$

$$f = \frac{1}{20 \times 10^{-3}}$$

$$f = 50 \text{ Hz.}$$

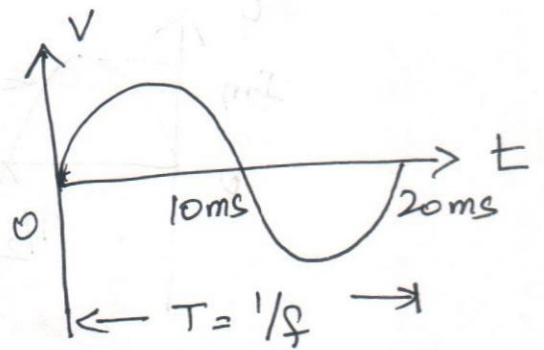

Average value:-

The average value of an alternating current is that value of steady direct current which transfers the same charge as the alternating current flowing for the same time

$$\text{Average value} = \frac{\text{Area under the curve over one complete cycle}}{\text{Base (Time period)}}$$

⇒ For symmetrical waves, the average value is taken over half a cycle only.

⇒ For unsymmetrical waves, the average value is taken over one complete cycle.

① Find the average value of the sine wave shown in figure

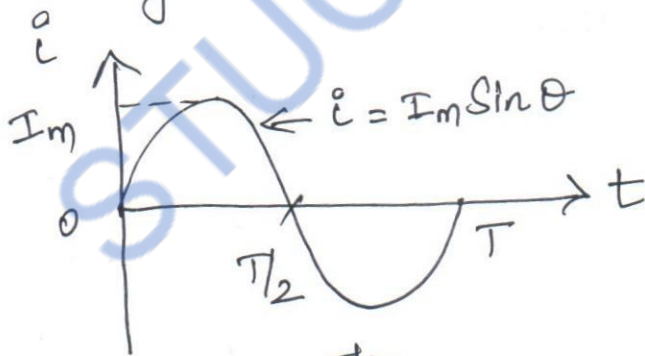

$$I_{av} = \frac{1}{T/2} \int_0^{T/2} i \cdot dt$$

$$I_{av} = \frac{1}{T/2} \int_0^{T/2} i \cdot dt \quad \left(\text{Put } T/2 = \pi \right)$$

$$I_{av} = \frac{1}{\pi} \int_0^{\pi} I_m \sin \theta \cdot d\theta$$

$$I_{av} = \frac{1}{\pi} \int_0^{\pi} I_m \sin \theta \cdot d\theta$$

$$= \frac{I_m}{\pi} \left[-\cos \theta \right]_0^{\pi}$$

$$= \frac{I_m}{\pi} \left[-\cos \pi + \cos 0 \right]$$

$$= \frac{I_m}{\pi} \left[-(-1) + 1 \right] \Rightarrow \frac{I_m}{\pi} [1+1] \Rightarrow \frac{2I_m}{\pi}$$

$$I_{av} = \frac{2I_m}{\pi}$$

2) Find the average value of the (i) Full Rectified sine wave (fig a) (ii) Half rectified sine wave (fig b)

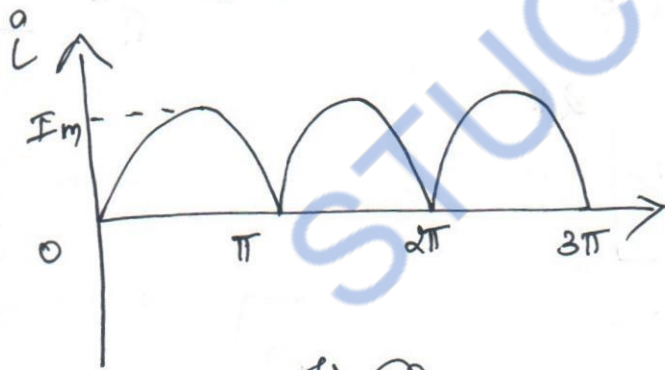

Fig (a)

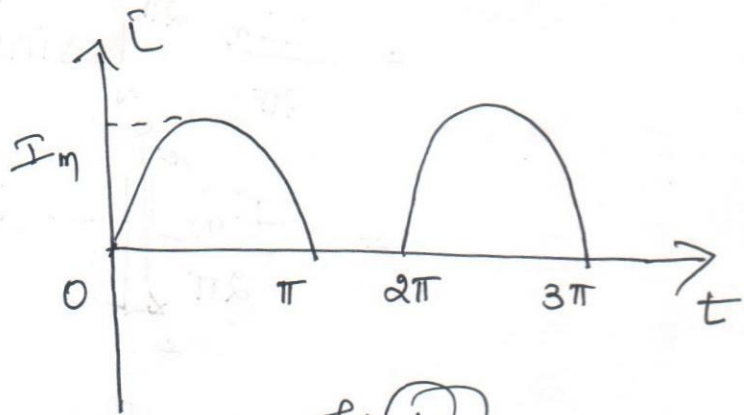

Fig (b)

Solution:-

Period is $\pi/2$ sec (or π radians)

$$I_{av} = \frac{1}{\pi/2} \int_0^{\pi/2} i \cdot dt = \frac{1}{\pi} \int_0^{\pi} i_m \sin \theta \cdot d\theta$$

$$I_{av} = \frac{I_m}{\pi} [-\cos\theta]_0^\pi \Rightarrow \frac{I_m}{\pi} [-\cos\pi - (-\cos 0)]$$

$$I_{av} = \frac{I_m}{\pi} [-(-1) + 1] \Rightarrow \frac{I_m}{\pi} [1+1] = \frac{2I_m}{\pi}$$

$$\boxed{I_{av} = \frac{2I_m}{\pi}}$$

(ii) Period is 'T' sec (2π radians) as the wave is Unsymmetrical.

$$I_{av} = \frac{1}{T} \int_0^T i dt = \frac{1}{2\pi} \int_0^{2\pi} i \cdot d\theta$$

$$I_{av} = \frac{1}{2\pi} \int_0^{2\pi} I_m \sin\theta \cdot d\theta = \frac{1}{2\pi} \left[\int_0^\pi I_m \sin\theta \cdot d\theta + \int_\pi^{2\pi} 0 \cdot d\theta \right]$$

$$= \frac{I_m}{2\pi} \int_0^{2\pi} \sin\theta \cdot d\theta$$

$$= \frac{I_m}{2\pi} [-\cos\theta]_0^{2\pi}$$

$$= \frac{I_m}{2\pi} [-\cos(2\pi) - (-\cos 0)]$$

$$= \frac{I_m}{2\pi} [-\cos(2\pi) - (-1)]$$

$$= \frac{I_m}{2\pi} [-(-1) - (-1)] \Rightarrow \frac{I_m}{2\pi} [1+1]$$

$$= \frac{I_m}{2\pi} (2) \Rightarrow \boxed{\frac{I_m}{\pi} = I_{av}}$$

RMS value! (Root Mean Square value).

The effective value of the alternating current is the value of steady direct current which produces the same heat as that produced by the alternating current when passed through the same resistor for the same interval of time.

Form Factor

$$\text{Form factor} = \frac{\text{RMS value}}{\text{Average value}}$$

Crest (or) Peak Factor

$$\text{Crest (peak factor)} = \frac{\text{Maximum value}}{\text{RMS value}}$$

① Find the RMS value of the sine wave shown in figure

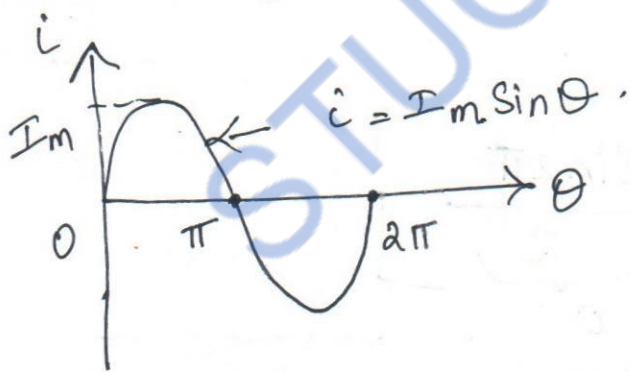

$$\begin{aligned} I_{\text{RMS}} &= \sqrt{\frac{1}{T} \int_0^T i^2(t) \cdot dt} \quad (\text{or}) \quad \sqrt{\frac{1}{\pi} \int_0^{\pi} i^2 d\theta} \\ &= \sqrt{\frac{1}{\pi} \int_0^{\pi} (I_m \sin \theta)^2 d\theta} \\ &= \sqrt{\frac{I_m^2}{\pi} \int_0^{\pi} \sin^2 \theta \cdot d\theta} \end{aligned}$$

$$= \sqrt{\frac{I_m^2}{\pi} \int_0^\pi \frac{1 - \cos 2\theta}{2} \cdot d\theta} \quad \because \sin^2 \theta = \frac{1 - \cos 2\theta}{2}$$

$$= \sqrt{\frac{I_m^2}{2\pi} \int_0^\pi 1 - \cos 2\theta \cdot d\theta}$$

$$= \sqrt{\frac{I_m^2}{2\pi} \left[\int_0^\pi d\theta - \int_0^\pi \cos 2\theta \cdot d\theta \right]}$$

$$= \sqrt{\frac{I_m^2}{2\pi} \left[\left[\theta \right]_0^\pi - \left[\frac{\sin 2\theta}{2} \right]_0^\pi \right]} \quad (\because \sin 0 = 0)$$

$$= \sqrt{\frac{I_m^2}{2\pi} \left[(\pi - 0) - \left(\frac{\sin 2\pi - \sin 0}{2} \right) \right]}$$

$$= \sqrt{\frac{I_m^2}{2\pi} \left[\pi - \frac{\sin 2\pi}{2} \right]}$$

$$= \sqrt{\frac{I_m^2}{2\pi} (\pi - 0)} = \sqrt{\frac{I_m^2}{2\pi} (\pi)}$$

$$= \sqrt{\frac{I_m^2}{2\pi} \times \pi} = \sqrt{\frac{I_m^2}{2}} = \frac{I_m}{\sqrt{2}}$$

$$\boxed{I_{RMS} = \frac{I_m}{\sqrt{2}}}$$

① Find the average and effective values of the saw-tooth waveform shown in figure.

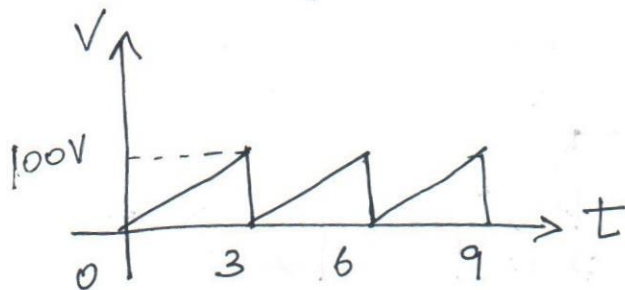

Solution:-

$$\text{Average value} = \frac{\text{Area of the Sawtooth under one cycle}}{\text{Period}}$$

$$\text{Period} = 3 \text{ (s)}$$

$$\text{Maximum value} = 100 \text{ V (V)}$$

$$\text{Area of the Sawtooth} = \frac{1}{2}bh \text{ (triangle).}$$

$$= \frac{1}{2} \times 3 \times 100 = 150$$

$$\text{Average value} = \frac{150}{3} = 50 \text{ V.}$$

$$\text{RMS value} = \sqrt{\frac{\text{Area of the squared wave}}{\text{Period}}}$$

Area of the square wave under one cycle

= Area of the parabola under one cycle

$$= \frac{1}{3} V_m^2 T \Rightarrow \frac{1}{3} (100)^2 (3) = 10000$$

$$\text{RMS value} = \sqrt{\frac{10000}{3}} = 57.73 \text{ V.}$$

② Find the form factor and peak factor for the voltage waveforms

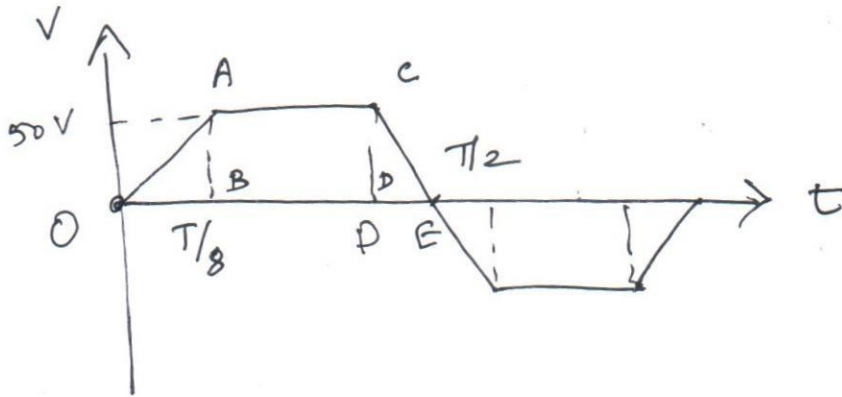

Solution:-

$$\text{Form factor} = \frac{\text{RMS Value}}{\text{Average Value}}$$

$$\text{Peak factor} = \frac{\text{Maximum Value}}{\text{RMS Value}}$$

$$\text{RMS value} = \sqrt{\frac{\text{Area of the Squared wave}}{\text{Period}}}$$

Since the wave is symmetrical, the average value is found over half a cycle (ie upto $T/2$).

Area of the squared wave for a half cycle } =

Area of squared wave for ΔOAB +

Area of squared wave for ΔCDE

Area of squared wave for rectangle (ACDB)

$$= \left[\frac{1}{3} (50)^2 \cdot \frac{T}{8} \right] + \left[\frac{1}{3} (50)^2 \cdot \frac{T}{8} \right] + \left[(50)^2 \cdot \frac{T}{4} \right]$$

$$= 2 \times \frac{1}{3} (50)^2 \left(\frac{T}{8} \right) + (50)^2 \cdot \frac{T}{4}$$

$$= 208.33T + 625T \Rightarrow 833.35T$$

$$\text{RMS Value} = \sqrt{\frac{833.35T}{(T/2)}} = \underline{\underline{40.82V}}$$

$$\boxed{\text{RMS value} = 40.82V}$$

$$\text{Form Factor} = \frac{\text{RMS value}}{\text{Average value}} = \frac{40.82}{37.5} = 1.088$$

$$\text{Average value} = \frac{\text{Area of the waveform under half the cycle}}{T/2}$$

$$\text{Area value} = \frac{\text{Area of the waveform under half the cycle}}{\text{Period}}$$

Area of the waveform under half the cycle

$$= \text{Area of } \triangle OAB + \text{Area of } \triangle CDE + \text{Area of rectangle ACDB}$$

$$\text{① Area of } \triangle OAB = \frac{1}{2} bh = \left(\frac{1}{2} \right) \left(\frac{T}{8} \right) (50) = 3.125T$$

$$\text{Area of } \triangle CDE = \frac{1}{2} bh = \left(\frac{1}{2} \right) \left(\frac{T}{8} \right) (50) = 3.125T$$

Area of Rectangle ACDB

$$= b \times h = \frac{T}{4} \times 50 = 12.5T$$

∴ Area of the waveform under half the cycle

$$= 3.125T + 3.125T + 12.5T = 18.75T$$

$$\text{Average value} = \frac{18.75T}{T/2} = 37.5V$$

$$\text{Average value} = 37.5V$$

$$\text{RMS value} = 40.82V$$

$$\text{Form Factor} = \frac{\text{RMS Value}}{\text{Average value}} = \frac{40.82}{37.5} = 1.088$$

$$\text{Peak Factor} = \frac{\text{Maximum value}}{\text{RMS value}} = \frac{50}{40.82} = 1.22$$

$$\text{Peak Factor} = 1.22$$

③ A sinusoidal voltage of frequency 50 Hz has a maximum value of 240V. What is its equation? Find the value of the voltage at (a) time $t = 0.0025$ s after the voltage passes through zero and is increasing and at (b) time $t = 0.001$ second after the voltage passes thro' zero and is decreasing.

Solution

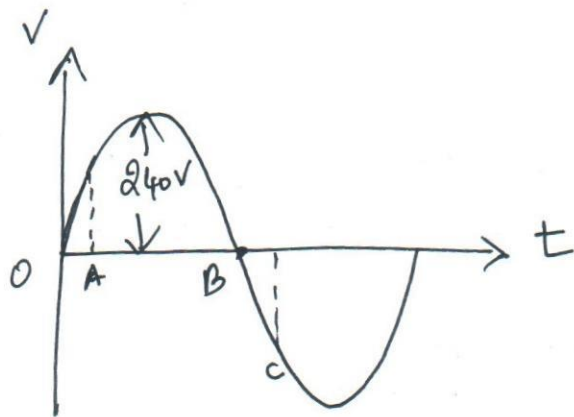

Frequency = 50 Hz
 $V_m = 240V$

Equation $V = V_m \sin \omega t$ ($\omega = 2\pi f$)

$$V = V_m \sin 2\pi f t$$

$$= (240)(\sin 2\pi)(50)(t)$$

$$= 240 \sin 314 t \text{ Volts}$$

a) At time $t = 0.0025$ s, after the voltage passes through zero and is increasing. (Passes thro' A)

$$V = 240 \sin 314 t$$

Here $t = 0.0025$ seconds.

$$\therefore V = 240 \sin (314)(0.0025)$$

$$V = 240 \sin 45^\circ$$

$$V = 169.70 V$$

Note (Radians to Degree)

$$314 \times 0.0025$$

$$= 0.785 \times \frac{180}{\pi}$$

$$= 44.97$$

$$\Rightarrow \underline{45^\circ}$$

b) At $t = 0.001$ sec, voltage passes through zero and decreasing (Passes thro' C)

$$V = 240 \sin 314 t$$

$$V = 240 \sin 314 (0.001)$$

$$314 \times 0.001$$

$$= 0.314 \times \frac{180}{\pi}$$

Once again 314×0.001 is in radians. The radian value is converted into degree $3.454 \times \frac{180}{\pi} = 197.8^\circ \Rightarrow V = 240 \sin 197.8^\circ$

$$V = -73.76 V$$

PHASOR DIAGRAM:-

An alternating quantity (current or voltage) is a vector quantity. A vector is a phasor that is rotating to a constant angular velocity.

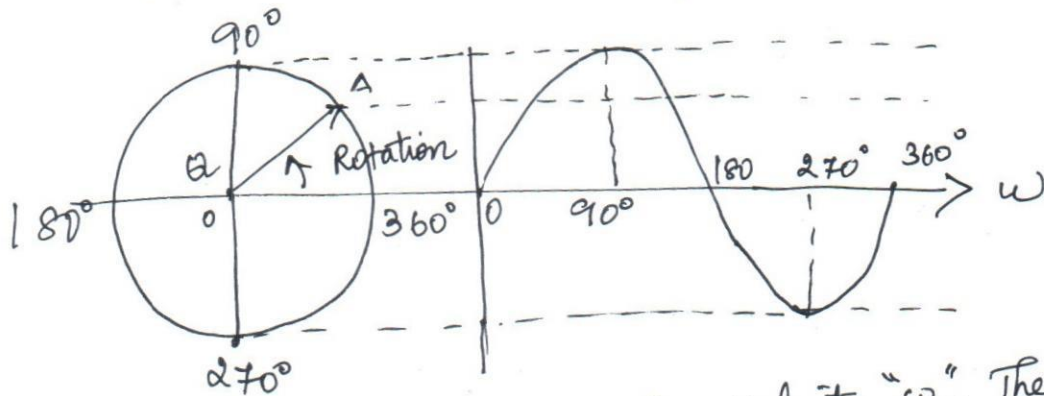

OA is a phasor with constant angular velocity " ω ". The phasor length is equal to maximum value of the voltage or current. By convention, the direction of vector (Phasor) rotation is taken as anticlockwise. Length of the phasor should be equal to the maximum value of alternating quantity.

PHASE DIFFERENCE:-

Consider '2' quantities

$$i_1 = I_m \sin \omega t, \quad i_2 = I_m \sin(\omega t - \phi), \quad i_3 = I_m \sin(\omega t + \phi)$$

i_1, i_2 & i_3 are sinusoidal quantities varying with the same peak value and frequency.

i_1, i_2 & i_3 do not reach maximum & minimum values at the same instant of time.

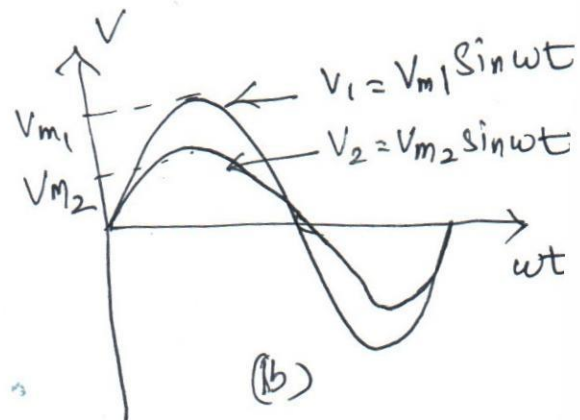
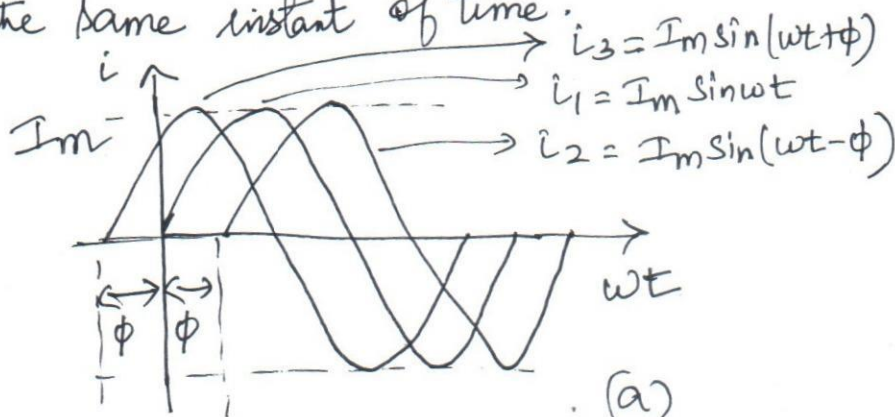

→ The current ' i_1 ' leads ' i_2 ' by ϕ degrees (or) ' i_2 ' lags behind ' i_1 ' by ϕ .

→ Also the current $i_3 = I_m \sin(\omega t + \phi)$ is said to lead ' i_1 ' by ϕ° .

→ Another example, consider

$$V_1 = V_m \sin \omega t$$

$$V_2 = V_m \sin \omega t$$

These two are in phase as they reach their maximum and minimum values at the same time and at the same frequency.

COMPLEX FORM:-

$$OA = OD + j DA$$

Phasor

$$OA = I \angle \alpha$$

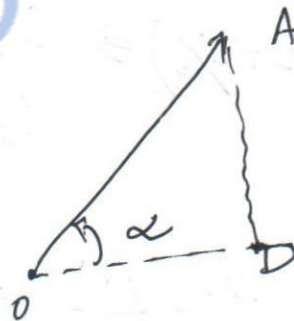

OD → Horizontal Component
DA → Vertical Component

$$OD = I \cos \alpha$$
$$DA = I \sin \alpha$$

$(a + jb)$

Rectangular form (or) Complex form is convenient

For Addition & Subtraction ⇒

For multiplication & Division ⇒ Polar form is convenient

$a \angle b$

CONVERSION (USING CALCULATOR)

Rectangular to Polar

$$\left. \begin{array}{l} \text{Shift, Polar}(a, b) = \frac{x}{y} \text{ (one value)} \\ \text{Alpha, tan}(\) = \frac{y}{x} \text{ (Another value)} \end{array} \right\} \Rightarrow x \angle y$$

(Polar form)

Polar to Rectangular

$$\left. \begin{array}{l} \text{Shift, Rect}(a, b) = \frac{z}{m} \text{ (one value)} \\ \text{Alpha, tan}(\) = \frac{m}{z} \text{ (Another value)} \end{array} \right\} \frac{z + jm}{\text{(Rectangular form)}}$$

Problem: A coil of wire carries simultaneously the currents $i_1 = 12 \sin \omega t$ and $i_2 = 10 \sin(\omega t + \pi/3)$. Find the total current

Sol $i_1 = 12 \sin \omega t \Rightarrow i_1 = I_{m1} \sin \omega t \Rightarrow \boxed{I_{m1} = 12}$

$i_2 = 10 \sin(\omega t + \pi/3) \Rightarrow i_2 = I_{m2} \sin(\omega t + \frac{180}{3})$

$i_2 = I_{m2} \sin(\omega t + 60^\circ)$

$$\boxed{I_{m2} = 10}$$

$$I_1 = \frac{I_{m1}}{\sqrt{2}} = \frac{12}{\sqrt{2}} \angle 0^\circ = 8.48 \angle 0^\circ \text{ A}$$

$$I_2 = \frac{I_{m2}}{\sqrt{2}} = \frac{10}{\sqrt{2}} \angle 60^\circ = 7.07 \angle 60^\circ \text{ A}$$

$$\text{TOTAL CURRENT } I = I_1 + I_2 = 8.48 \angle 0^\circ + 7.07 \angle 60^\circ$$

$$I = 8.48 + j0 + 3.535 + j6.122$$

$$I = 12.015 + j6.122 \Rightarrow \boxed{I = 13.5 \angle 27^\circ \text{ A}}$$

(For Addition Convert into Rectangular Form)

Phase Diagram

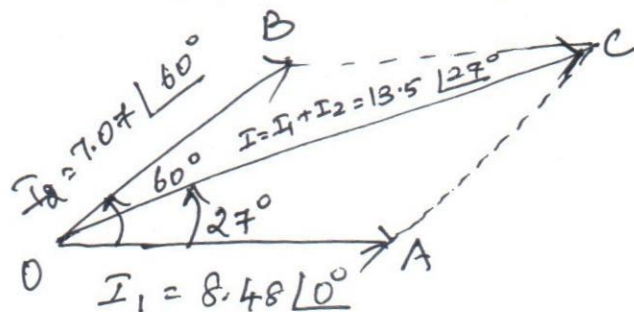

STEADY STATE ANALYSIS OF SINGLE PHASE AC CIRCUITS:-

(26)

Resistor :-

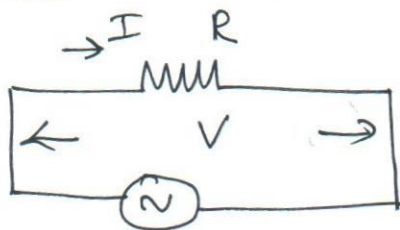

$$V = V_m \sin \omega t$$

$$i = \frac{V}{R} = \frac{V_m \sin \omega t}{R}$$

The value of current will be maximum when $\sin \omega t = 1$ ($\omega t = 90^\circ$)

$$I_m = \frac{V_m}{R}$$

$$i = I_m \sin \omega t$$

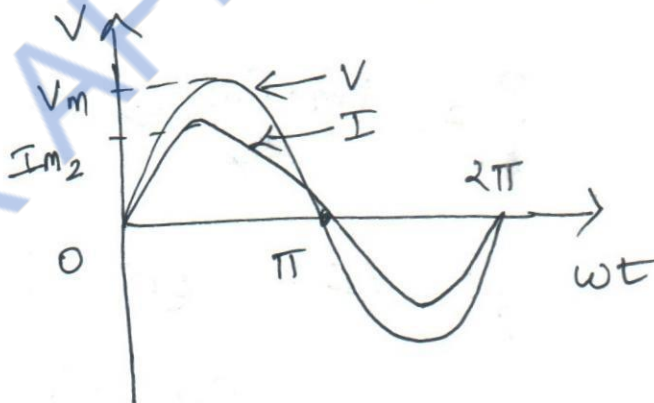

$$\text{Power} = V \cdot i = V_m \sin \omega t \cdot I_m \sin \omega t$$

$$\text{Average power } P = \frac{1}{2\pi} \int_0^{2\pi} P \cdot d(\omega t)$$

$$= \frac{1}{\pi} \int_0^{\pi} V_m \sin \omega t \cdot I_m \sin \omega t \cdot d\omega t$$

$$= \frac{V_m I_m}{\pi} \int_0^{\pi} \sin^2 \omega t \cdot d(\omega t)$$

$$= \frac{V_m I_m}{\pi} \int_0^{\pi} \left(\frac{1 - \cos 2\omega t}{2} \right) d(\omega t)$$

$$= \frac{V_m I_m}{2\pi} \int_0^{\pi} 1 - \cos 2\omega t \cdot d\omega t$$

$$= \frac{V_m I_m}{2\pi} \left[\left(\omega t - \frac{\sin 2\omega t}{2} \right) \right]_0^{\pi}$$

$$= \frac{V_m I_m}{2\pi} \left[\left(\pi - \frac{\sin 2\pi}{2} \right) - \left(0 - \frac{\sin 0}{2} \right) \right]$$

$$= \frac{V_m I_m}{2\pi} [\pi - 0] \Rightarrow \frac{V_m I_m}{2\pi} \times \pi \Rightarrow \frac{V_m I_m}{2}$$

$$P = \frac{V_m \cdot I_m}{2} \Rightarrow \frac{V_m}{\sqrt{2}} \cdot \frac{I_m}{\sqrt{2}} = V \cdot I$$

$$\boxed{P = VI} \quad (\text{or}) \quad P = I^2 R$$

Where $V \Rightarrow$ RMS value of a/p voltage
 $I \Rightarrow$ RMS value of a/p current.

INDUCTOR

$$V = V_m \sin \omega t$$

emf induced $\propto \frac{di}{dt}$

$$V \propto \frac{di}{dt}$$

$$V = L \cdot \frac{di}{dt}$$

$L \Rightarrow$ constant of proportionality

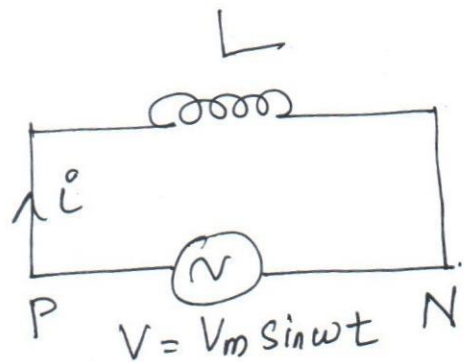

$$V_m \sin \omega t = L \cdot \frac{di}{dt}$$

$$di = \frac{V_m}{L} \cdot \sin \omega t \cdot dt$$

Integrating on both sides

$$\int di = \int \frac{V_m}{L} \cdot \sin \omega t \cdot dt$$

$$i = \frac{V_m}{L} \left(-\frac{\cos \omega t}{\omega} \right) = \frac{V_m}{\omega L} \sin \left(\omega t - \frac{\pi}{2} \right)$$

$$i = \frac{V}{X_L} \sin \left(\omega t - \frac{\pi}{2} \right)$$

Here $\sin \left(\omega t - \frac{\pi}{2} \right) = 1$

$$\therefore I_m = \frac{V_m}{X_L}$$

Instantaneous power

$$P = v i$$

$$P = V_m \sin \omega t \cdot I_m \sin \left(\omega t - \frac{\pi}{2} \right)$$

$$= V_m I_m \sin \omega t \cos \omega t$$

$$= -V_m I_m \frac{\sin 2\omega t}{2}$$

$$= \frac{-V_m}{\sqrt{2}} \cdot \frac{I_m}{\sqrt{2}} \cdot \sin 2\omega t$$

$$\text{Power } P = \frac{V_m}{\sqrt{2}} \cdot \frac{I_m}{\sqrt{2}} \int_0^{\pi} \sin 2\omega t \cdot d\omega t$$

$$P_{av} = 0$$

Problems:-

① A 25Ω Resistance has a voltage v of $V = 150 \sin 311t$ Volts. Find the corresponding current & power.

Sol

$$V = V_m \sin \omega t$$

$$\Rightarrow V_m = 150V$$

$$V_a = \frac{V_m}{\sqrt{2}} = \frac{150}{\sqrt{2}} = 106.06V$$

$$\text{Current } I = \frac{V_a}{R} = \frac{106.06}{25} = 4.24A$$

$$\text{Power } P = I^2 R = (4.24)^2 (25) = 449.44W$$

② A pure inductor of $100mH$ has an applied voltage of $V = 240 \sin 314t$. Find the eqn for the

(i) current (ii) Instantaneous power. Find also the

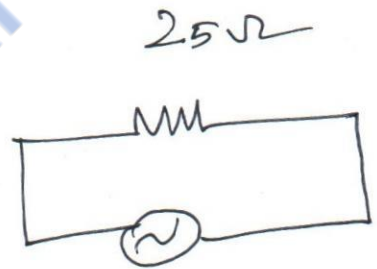

inductive reactance, rms value of current & (29)
Average power.

Sol $L = 100 \text{ mH}$, $V = 240 \sin 314 t$

$$V_m = 240 \text{ V}$$

$$\text{Angular frequency } \omega = 314 = 2\pi f$$

Inductive Reactance

$$\begin{aligned} X_L &= \omega L \\ &= (314)(0.1) = 31.4 \Omega \end{aligned}$$

RMS value of the current

$$\frac{I}{\text{RMS}} = \frac{V_{\text{RMS}}}{X_L} = \frac{169.7}{31.4} = 5.4 \text{ A}$$

$$V_{\text{RMS}} = \frac{V_m}{\sqrt{2}} = \frac{240}{\sqrt{2}} = 169.7 \text{ V}$$

$$i = I_m \sin(\omega t - \pi/2) = \underbrace{I_{\text{rms}} \cdot \sqrt{2}} \sin(\omega t - \pi/2)$$

$$i = 5.4 \times \sqrt{2} \sin(314t - \pi/2)$$

$$\boxed{i = 7.64 \sin(314t - \pi/2)}$$

Instantaneous power = v_i
 $(V_i) = (240 \sin 314t)$
 $(7.64 \sin(314t - \pi/2))$

$$P = 1833.6 \sin 314t \cdot \cos 314t$$

Current in an inductor lags the applied voltage by 90° ($\pi/2$ radians).

$$\boxed{P = 1833.6 \sin 314t \cdot \cos 314t} \text{ W}$$

Average power = $P_{\text{av}} = 0$

A 127 MF capacitor has 125V, 50 Hz supply. Calculate
 (i) Capacitive reactance, (ii) RMS current (iii) Instantaneous
 power (iv) Average power.

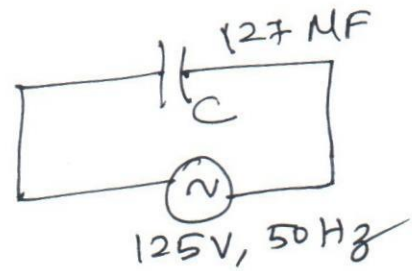

sol
 (i) Capacitive Reactance (X_c)

$$X_c = \frac{1}{2\pi f C} = \frac{1}{(2\pi)(50)(127 \times 10^{-6})} = 25.06 \Omega$$

(ii) RMS Current (I)

$$I_{rms} = \frac{V_{rms}}{X_c} = \frac{125}{25.06} = 4.988 \text{ A}$$

(iii) Instantaneous power (P)

$$P = v i$$

$$= V_m \sin \omega t \cdot I_m \sin(\omega t + \pi/2)$$

$$\omega = 2\pi f = (2\pi)(50) = 314$$

$$V_m = \sqrt{2} V_{rms} = (\sqrt{2})(125) = 176.77 \text{ V}$$

$$I_m = \sqrt{2} I_{rms} = (\sqrt{2})(4.988) = 7.05 \text{ A}$$

$$\therefore P = (176.77 \sin 314 t) (7.05 \sin(314 t + \pi/2))$$

(iv) Average power

$$\boxed{P = 0}$$

Expression for Power & Power Factor.

30

RL Series Circuit :-

$R \Rightarrow$ Resistance in Ω

$L \Rightarrow$ Inductance in Henry

$I \Rightarrow$ Current flowing in RL series circuit

$V \Rightarrow$ S/P voltage

$V_R =$ Voltage drop across $R = IR$

$V_L =$ Voltage drop across $L = I \times X_L$

$X_L =$ Inductive reactance in $\Omega = 2\pi fL$

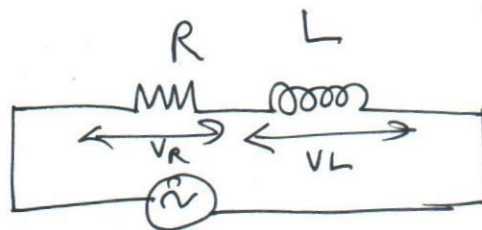

(X) Resistive \Rightarrow Current & Voltage are in Phase



(X) Inductive \Rightarrow Current lags the voltage by 90°

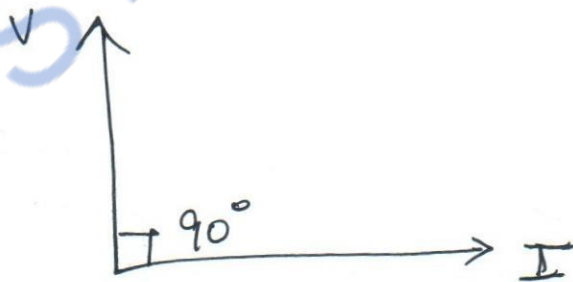

Combining these 2 figures, we get the phasor diagram for RL circuit

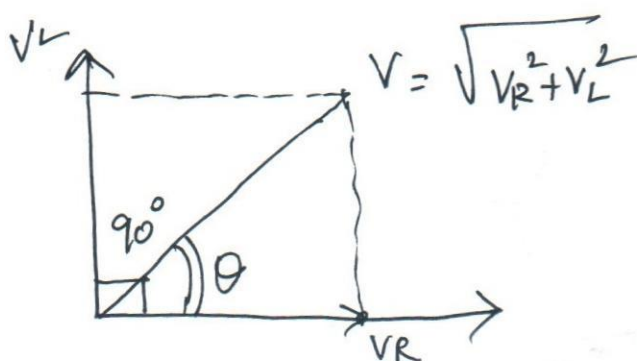

$$\text{Impedance } Z = R + jX_L$$

$$= \sqrt{R^2 + X_L^2}$$

$$Z = \frac{V}{I}$$

$$\text{Phase angle } \phi = \tan^{-1} \left(\frac{X_L}{R} \right)$$

$$\text{Power factor} = \cos \phi \text{ (Lag)} = \frac{R}{Z}$$

$$\text{Apparent power } S = |V| |I|$$

$$\text{Real power } P = |V| |I| \cos \phi = S \cos \phi$$

$$\text{Reactive power } Q = |V| |I| \sin \phi = S \sin \phi$$

- ① A coil having a resistance of 7Ω and an inductance of 31.8 mH is connected to 230V 50Hz supply. Calculate the circuit current, phase angle, power factor and power consumed.

Sol

$$\text{Resistance } R = 7 \Omega$$

$$\text{Inductance } L = 31.8 \text{ mH}$$

$$V = 230 \text{ V}$$

$$f = 50 \text{ Hz}$$

$$\text{Current } I = \frac{V}{Z}$$

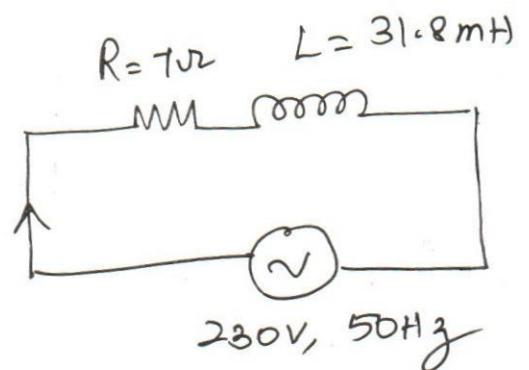

Impedance $Z = \sqrt{R^2 + X_L^2} = \sqrt{(7)^2 + (10)^2} = 12.2 \Omega$

Current $\Rightarrow I = \frac{V}{Z} = \frac{230}{12.2} = 18.85 \text{ A}$

Phase angle $\phi = \tan^{-1} \left(\frac{X_L}{R} \right) \Rightarrow \tan^{-1} \left(\frac{10}{7} \right)$

To find X_L

$X_L = 2\pi fL = (2\pi)(50)(31.8) \times 10^{-3} = 10 \Omega$

\therefore Phase angle $\phi = \tan^{-1} \left(\frac{10}{7} \right) = 55^\circ$

Power factor $\cos\phi = \cos 55 = \underline{0.573 \text{ (Lag)}}$

Power Consumed $P = VI \cos\phi$
 $= (230)(18.85)(0.573)$
 $= \underline{2484.24 \text{ W}}$

\therefore Current $I = 18.85 \text{ A}$

Phase angle $\phi = 55^\circ$

Power factor $\cos\phi = 0.573 \text{ (Lag)}$

Power Consumed $P = 2484.24 \text{ W}$

② A 100Ω Resistor and a 20mH inductor are connected in series across a 230V , 50Hz supply. Find Circuit Impedance, Admittance, Current, Voltage across Resistor, voltage across inductor, Apparent power, Active power and power factor.

Sol

$$R = 100\Omega$$

$$L = 20\text{mH} = 20 \times 10^{-3}\text{H}$$

$$V = 230\text{V}$$

$$f = 50\text{Hz}$$

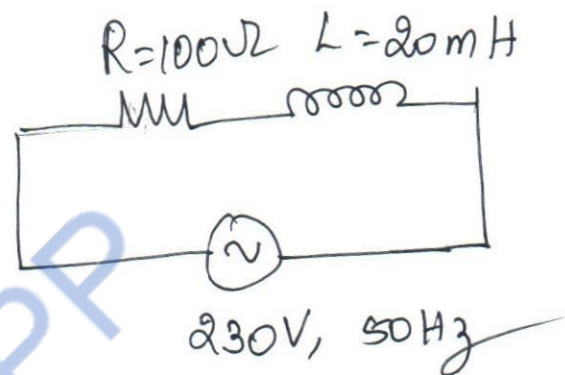

① Circuit Impedance $Z = \sqrt{(R)^2 + (X_L)^2}$

To find $X_L = 2\pi fL = (2\pi)(50)(20 \times 10^{-3})$

$$X_L = 6.283\Omega$$

$$\therefore Z = \sqrt{(100)^2 + (6.283)^2} = 100.197\Omega$$

Admittance $Y = \frac{1}{Z} = \frac{1}{100.197} = 9.98 \times 10^{-3}\text{S}$

Current $I = \frac{V}{Z} = \frac{230}{100.19} = 2.295\text{A}$

Voltage across the resistor $V_R = IR$
 $= (2.295)(100)$

$$V_R = 229.5\text{V}$$

Voltage across Inductor $V_L = I X_L$

$$V_L = 2.295 \times 6.283$$

$$V_L = 14.42 \text{ V}$$

Active power $P = I^2 R = (2.295)^2 \times 100$

$$P = 526.7 \text{ W}$$

Apparent power $S = VI$

$$= (230)(2.295) = 527.85 \text{ VA}$$

Power Factor $\cos \phi = \frac{R}{Z} = \frac{100}{100.197} = 0.998 \text{ (lag)}$

$$\therefore \cos \phi = 0.998 \text{ lag}$$

RC Series circuit

Resistor & Capacitor are connected in series

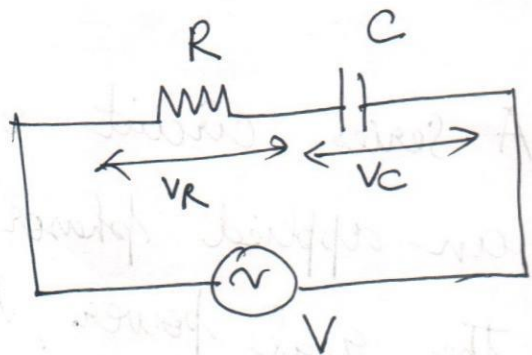

$R \Rightarrow$ Resistance in Ω

$C \Rightarrow$ Capacitance in F

$I \Rightarrow$ Current flowing through the RC circuit

$V \Rightarrow$ Input voltage

$V_R \Rightarrow$ Voltage drop across resistance = IR

$V_C \Rightarrow$ Voltage drop across Capacitance = $I X_C$

For Resistor circuit
 V_R & I are in phase

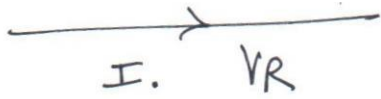

For Capacitor circuit alone

'I' leads the voltage by 90°

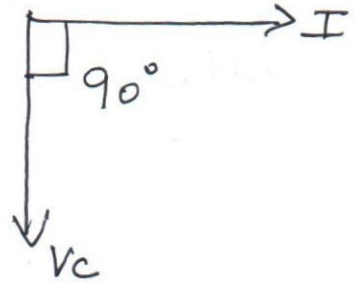

$$\text{Impedance } Z = \sqrt{R^2 + (X_C)^2}$$

$$Z = R + (-jX_C) \Rightarrow \sqrt{R^2 + X_C^2}$$

$$\text{Phase angle } \phi = \tan^{-1}\left(\frac{X_C}{R}\right) \text{ (Lead)}$$

$$\text{Power Factor} = \cos \phi = \frac{R}{|Z|} \text{ (Lead)}$$

$$\text{Apparent power } S = |V| |I|$$

$$\text{Real power } P = |V| |I| \cos \phi$$

$$\text{Reactive power } Q = |V| |I| \sin \phi$$

① A series circuit of $R = 10\Omega$ and $X_C = 15\Omega$ has an applied phasor voltage $V = 50 \angle -90^\circ \text{ V}_{\text{rms}}$. Find the real power, Reactive power, Complex power & power factor.

Sol

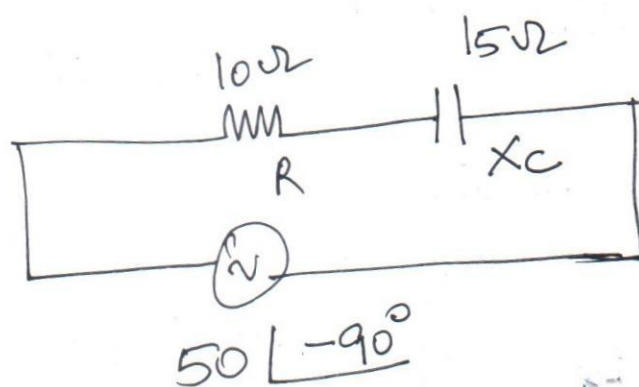

Impedance $Z = R - jX_C$

$$= 10 - j15 = 18.02 \angle -56.30^\circ \Omega$$

Current $I = \frac{V}{Z} = \frac{50 \angle -90^\circ}{18.02 \angle -56.30^\circ}$

$$I = 2.77 \angle -33.7^\circ \text{ A}$$

Real power $P = I^2 R = (2.77)^2 \times 10$

$$P = 76.729 \text{ W}$$

Power factor $\cos \phi = \cos(-56.30)$

$$\cos \phi = 0.5548 \text{ (Lead)}$$

$$\sin \phi = 0.831$$

Reactive power $Q = |V| |I| \sin \phi$

$$= (50)(2.77)(0.831)$$

$$Q = 115 \text{ VAR}$$

Complex power (or) Apparent power

$$S = |V| |I| = 50 \times 2.77$$

$$S = 138.5 \text{ VA}$$

RLC Series Circuit:

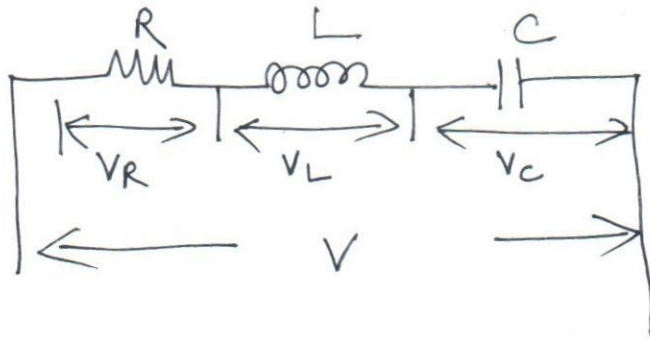

$$V_R \rightarrow \text{RMS voltage across 'R'} = IR \angle 0^\circ$$

$$V_L \Rightarrow \text{RMS voltage across 'L'} = IX_L \angle 90^\circ (\text{lag}) \Rightarrow jIX_L$$

$$V_C \Rightarrow \text{RMS voltage across 'C'} = IX_C \angle -90^\circ (\text{lead}) \Rightarrow -jIX_C$$

$$\text{Total rms voltage } (V_{\text{rms}}) = V_R + V_L + V_C$$

$$V = IR + jIX_L - jIX_C$$

$$= I [R + j(X_L - X_C)]$$

Where $R + j(X_L - X_C)$ is called the Impedance of the circuit and given by symbol " Z "

$$\boxed{Z = R + j(X_L - X_C)}$$

$$|Z| = \sqrt{R^2 + (X_L - X_C)^2}$$

$$\boxed{\phi = \tan^{-1} \left(\frac{X_L - X_C}{R} \right)}$$

The phasor diagram $X_L > X_C$ (ϕ is positive)
 $X_C > X_L$ (ϕ is negative)

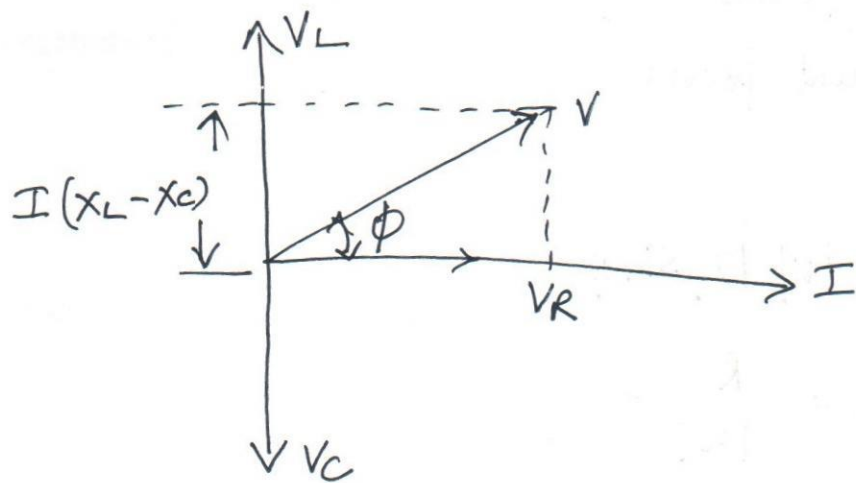

Phasor diagram.

* The Average power in such RLC circuit is given by the power in the resistor alone and the average power is zero in 'L' and 'C'.

$$\text{Power in the circuit} = |I|^2 R = \frac{|V|^2}{|Z|^2} \cdot R$$

$$= \frac{|V| |V| |R|}{|Z| |Z|}$$

$$= |V| |I| \cos \phi$$

$$\therefore \cos \phi = \frac{R}{\sqrt{R^2 + (X_L - X_C)^2}}$$

Power may be calculated as $\frac{|V_R|^2}{R}$.

Apparent power = $|V| |I|$

Real power = $|V| |I| \cos \phi$

$$\cos \phi = \frac{\text{Real power}}{\text{Apparent power}}$$

(Power Factor)

$$\text{Reactive power} = |V| |I| \sin \phi$$

$$\text{Power Factor} = \frac{R}{|Z|}$$

① In a series RLC circuit $R = 24 \Omega$, $L = 191 \text{ mH}$ and $C = 66.3 \mu\text{F}$ given that the supply voltage is 240 V , 60 Hz . Find (i) Equivalent Impedance (ii) Power factor (iii) Current (iv) Power and (v) Reactive power.

Solution

Given

$$R = 24 \Omega$$

$$L = 191 \text{ mH}$$

$$L = 191 \times 10^{-3} \text{ H}$$

$$C = 66.3 \mu\text{F}$$

$$C = 66.3 \times 10^{-6} \text{ F}$$

$$V = 240 \text{ V}$$

$$f = 60 \text{ Hz}$$

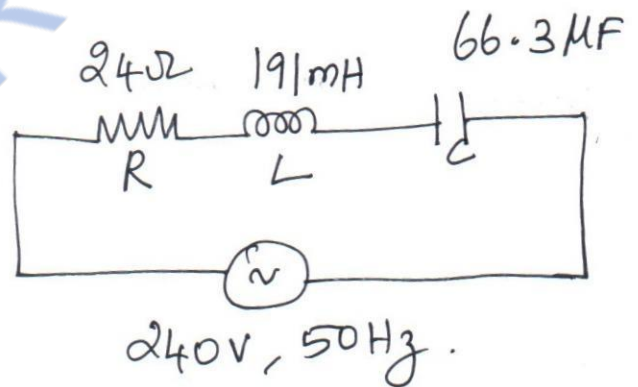

Impedance $z = R + j(X_L - X_C)$

To find X_L & X_C

$X_L = 2\pi fL = (2\pi)(60)(191 \times 10^{-3})$

$X_L = 72 \Omega$

$X_C = \frac{1}{2\pi fC} = \frac{1}{(2\pi)(60)(66.3 \times 10^{-6})} = 40 \Omega$

$X_C = 40 \Omega$

∴ Equivalent Impedance $z = R + j(X_L - X_C)$

$z = 24 + j(72 - 40) = 24 + j32 \Rightarrow 40 \angle 53.13^\circ$

$z = 40 \Omega$

Power Factor $\cos \phi = \cos(53.13) \text{ (or) } \frac{R}{|z|} = \frac{24}{40}$

$\cos \phi = 0.6 \text{ (Lag)}$

Current $I = \frac{V}{z} = \frac{240 \angle 0^\circ}{40 \angle 53.13} = 6 \angle -53.13^\circ \text{ A}$

$|I| = 6 \text{ A}$

Real power $P = |V| |I| \cos \phi = 240 \times 6 \times 0.6 = 864 \text{ W}$

$P = 864 \text{ W}$

Reactive power $Q = |V| |I| \sin \phi = 240 \times 6 \times 0.8 = 1152 \text{ VAR}$

STUCOR APP

Problems based on Power calculation, Energy calculation

and ohm's law.

① A 5Ω resistor has a voltage rating of $100V$, what is the power rating.

Given:

$$R = 5\Omega$$

$$V = 100V$$

To find:

Power rating

Solution:

$$P = \frac{V^2}{R}$$

$$P = \frac{(100)^2}{5}$$

$$P = 2000 \text{ Watts}$$

② A resistor with a current of $3A$ through it converts $500J$ of electrical energy into heat energy in 12 seconds. what is the voltage across the resistor?

Given:

$$I = 3 \text{ Amperes}$$

$$W = 500 \text{ Joules}$$

$$t = 12 \text{ seconds}$$

($I \rightarrow$ current)

($W \rightarrow$ Energy)

($t \rightarrow$ time)

To find:

Voltage across the resistor.

Solution:

$$W = V I t$$

$$\therefore 500 = V \times 3 \times 12$$

$$\therefore \frac{500}{3 \times 12} = V$$

$$\therefore V = \frac{500}{36}$$

$$V = 13.88 \text{ volts}$$

Problems from KCL

Find the current through $12\ \Omega$ resistor
 $(10-5)=5A$ $(4+2)=6A$

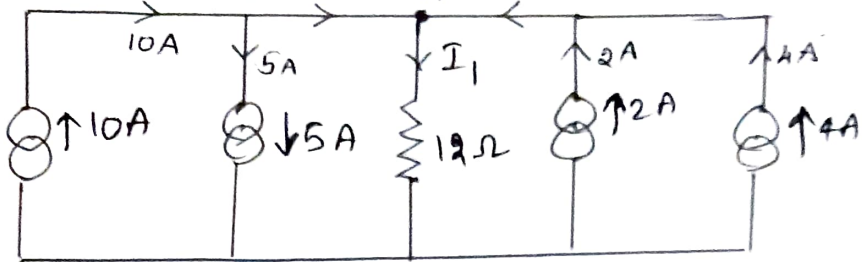

Consider node A,

current entering is positive, (Incoming current)
 current leaving is negative (outgoing current).

∴ Apply KCL at node "A",

$$+10 - 5 - I_1 + 2 + 4 = 0$$

$$\therefore -I_1 = -10 + 5 - 2 - 4$$

$$-I_1 = -11$$

Current through $12\ \Omega$ is: $I_1 = 11$ Amperes.

Problems from KVL

find the voltage across resistor "R".

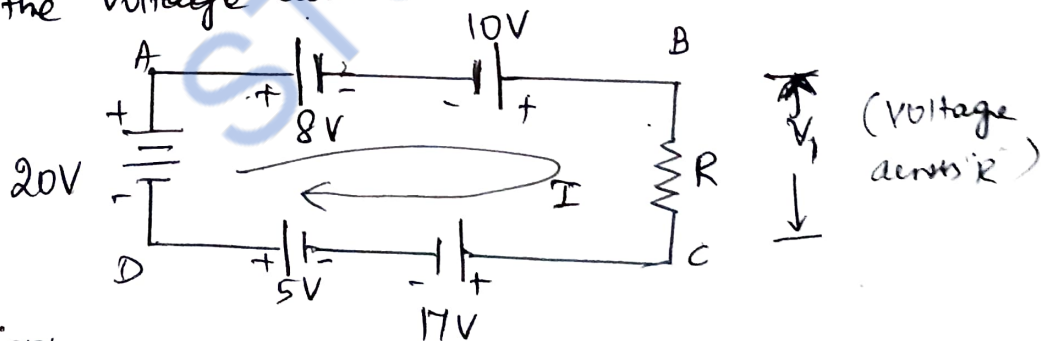

Solution:

* Apply KVL to the loop. (AB CDA)

* consider "I" closed loop current in clockwise direction.

Apply KVL to loop ABCDA.

$$-8 + 10 - IR - 17 + 5 + 20 = 0$$

$$-V_1 + 10 = 0$$

$$-V_1 = -10$$

Voltage across "R", $V_1 = 10V$

$$[\therefore V_1 = IR]$$

(1A)

MESH CURRENT ANALYSIS

- ① Determine the loop currents of the circuit shown in figure below. Also find current through 6Ω resistor.

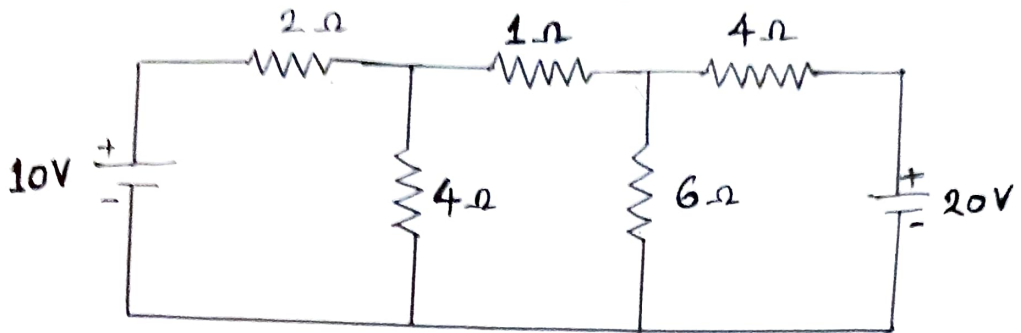

Solution:

* Apply the loop currents I_1, I_2, I_3 for the closed loops ①, ② and ③ respectively

* consider I_1, I_2, I_3 loop currents in clockwise direction.

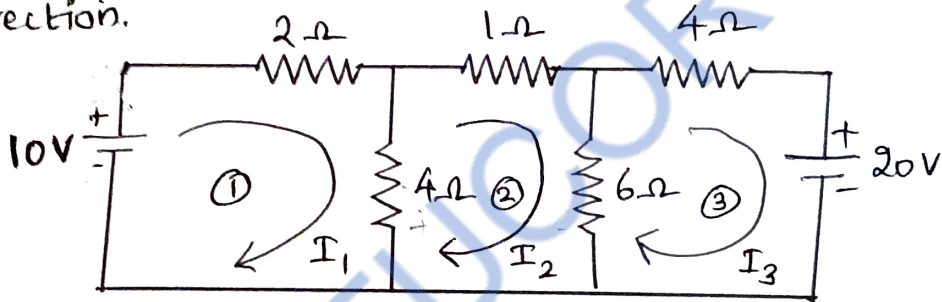

Apply KVL to loop 1 :-

$$+10 - 2I_1 - 4(I_1 - I_2) = 0$$

$$+10 - 2I_1 - 4I_1 + 4I_2 = 0$$

$$-6I_1 + 4I_2 = -10 \longrightarrow \text{①}$$

Apply KVL to loop 2 :-

$$-1I_2 - 6(I_2 - I_3) - 4(I_2 - I_1) = 0$$

$$-I_2 - 6I_2 + 6I_3 - 4I_2 + 4I_1 = 0$$

$$+4I_1 - 11I_2 + 6I_3 = 0 \longrightarrow \text{②}$$

Apply KVL to loop 3

$$-4I_3 - 20 - 6(I_3 - I_2) = 0$$

$$6I_2 - 10I_3 = 20 \longrightarrow \text{③}$$

From the equations ①, ② and ③,
 Arrange in the matrix form,

$$\begin{bmatrix} -6 & 4 & 0 \\ 4 & -11 & 6 \\ 0 & 6 & -10 \end{bmatrix} \begin{bmatrix} I_1 \\ I_2 \\ I_3 \end{bmatrix} = \begin{bmatrix} -10 \\ 0 \\ 20 \end{bmatrix}$$

$$\Delta = \begin{vmatrix} + & - & + \\ -6 & 4 & 0 \\ 4 & -11 & 6 \\ 0 & 6 & -10 \end{vmatrix}$$

$$\Delta = -6(-11 \times -10 - (6 \times 6)) - 4(4 \times -10 - (6 \times 0)) + 0$$

$$\Delta = -284$$

$$\Delta I_1 = \begin{vmatrix} + & - & + \\ -10 & 4 & 0 \\ 0 & -11 & 6 \\ 20 & 6 & -10 \end{vmatrix}$$

$$\Delta I_1 = -10(-11 \times -10 - (6 \times 6)) - 4(0 \times -10 - (6 \times 20)) + 0$$

$$\Delta I_1 = -260$$

$$\Delta I_2 = \begin{vmatrix} + & - & + \\ -6 & -10 & 0 \\ 4 & 0 & 6 \\ 0 & 20 & -10 \end{vmatrix}$$

$$\Delta I_2 = -6(0 \times -10 - (6 \times 20)) - (-10)(4 \times -10 - (0 \times 6)) + 0$$

$$\Delta I_2 = 320$$

$$\Delta I_3 = \begin{vmatrix} + & - & + \\ -6 & 4 & -10 \\ 4 & -11 & 0 \\ 0 & 6 & 20 \end{vmatrix}$$

$$\Delta I_3 = -6(-11 \times 20 - (6 \times 0)) - 4(4 \times 20 - 0 \times 0) - 10(4 \times 6 - (0 \times -11))$$

$$\Delta I_3 = 760$$

Loop currents (I_1, I_2, I_3):

$$I_1 = \frac{\Delta I_1}{\Delta} = \frac{-260}{-284}$$

$$I_1 = 0.915 \text{ Amperes}$$

$$I_2 = \frac{\Delta I_2}{\Delta} = \frac{-320}{-284} = \frac{320}{284}$$

$$I_2 = -1.126 \text{ Amperes.}$$

$$I_3 = \frac{\Delta I_3}{\Delta} = \frac{760}{-284} = \frac{-760}{284}$$

$$I_3 = -2.676 \text{ Amperes}$$

\therefore Current through 6Ω resistor = $I_3 - I_2$

$$\therefore I_{6\Omega} = I_3 - I_2$$

$$I_{6\Omega} = -2.676 - (-1.126)$$

$$I_{6\Omega} = -1.55 \text{ Amperes}$$

Answers:

1) Loop currents, $I_1 = 0.915 \text{ Amperes}$
(I_1, I_2, I_3)

$I_2 = -1.126 \text{ Amperes}$ (or)
1.126 Amperes (considered current direction is opposite).

$I_3 = -2.676 \text{ Amperes}$ (or)
2.676 Amperes (considered current direction is opposite).

2) Current through 6Ω resistor, $I_{6\Omega} = -1.55 \text{ Amperes}$.

(or) $I_{6\Omega} = 1.55 \text{ Amperes}$ (considered current direction is opposite)

- ②. Use mesh method of analysis to find the current through 4Ω resistor in the circuit shown in the figure.

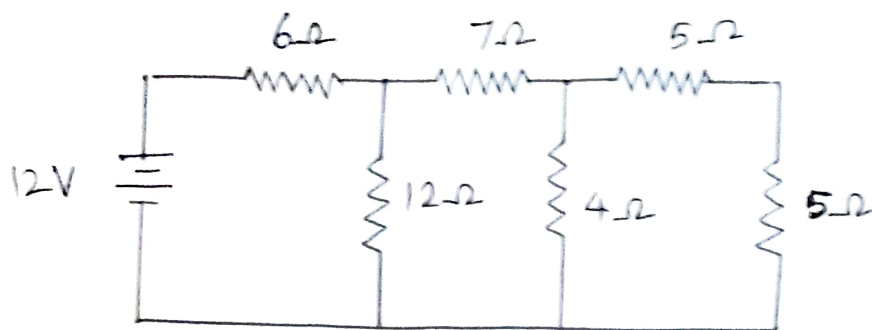

Solution:

* Apply loop current I_1, I_2, I_3 in clockwise direction for the loops 1, 2, 3.

* Consider the loop current I_1, I_2, I_3 in clockwise directions.

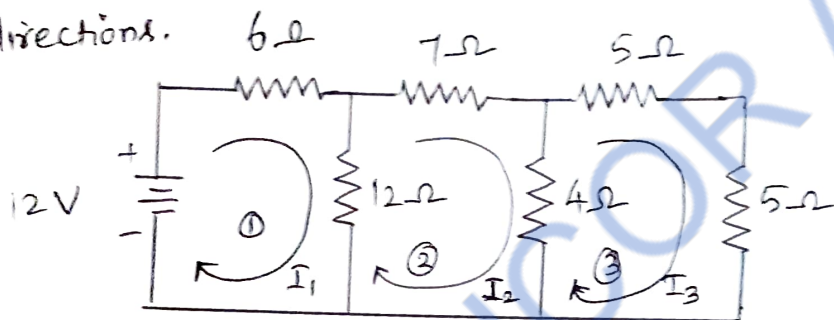

Apply KVL to loop 1,

$$-6I_1 - 12(I_1 - I_2) + 12 = 0.$$

$$-6I_1 - 12I_1 + 12I_2 + 12 = 0.$$

$$-18I_1 + 12I_2 = -12$$

$$\therefore -18I_1 + 12I_2 + 0I_3 = -12 \longrightarrow \textcircled{1}$$

Apply KVL to loop 2,

$$-7I_2 - 4(I_2 - I_3) - 12(I_2 - I_1) = 0$$

$$-7I_2 - 4I_2 + 4I_3 - 12I_2 + 12I_1 = 0$$

$$12I_1 - 23I_2 + 4I_3 = 0 \longrightarrow \textcircled{2}$$

Apply KVL to loop 3,

$$-5I_3 - 5I_3 - 4(I_3 - I_2) = 0$$

$$-5I_3 - 5I_3 - 4I_3 + 4I_2 = 0$$

$$4I_2 - 14I_3 = 0$$

$$\therefore 0I_1 + 4I_2 - 14I_3 = 0 \longrightarrow \textcircled{3}$$

By applying Cramer's rule, we can find current through 4Ω resistor

$$\begin{bmatrix} -18 & 12 & 0 \\ 12 & -23 & 4 \\ 0 & 4 & -14 \end{bmatrix} \begin{bmatrix} I_1 \\ I_2 \\ I_3 \end{bmatrix} = \begin{bmatrix} -12 \\ 0 \\ 0 \end{bmatrix}$$

$$\Delta = \begin{vmatrix} + & - & + \\ -18 & 12 & 0 \\ 12 & -23 & 4 \\ 0 & 4 & -14 \end{vmatrix}$$

$$\Delta = -18(-23 \times 4 - (4 \times 4)) - 12(12 \times -14 - 0) + 0.$$

$$\Delta = 5508 + 2016 = -3492$$

$$\Delta = -3492$$

$$\Delta I_1 = \begin{vmatrix} + & - & + \\ -12 & 12 & 0 \\ 0 & -23 & 4 \\ 0 & 4 & -14 \end{vmatrix}$$

$$\Delta I_1 = -12(-23 \times 4 - (4 \times 4)) - 12(0 - 0) + 0.$$

$$\Delta I_1 = -3672$$

$$\Delta I_2 = \begin{vmatrix} + & - & + \\ -18 & -12 & 0 \\ 12 & 0 & 4 \\ 0 & 0 & -14 \end{vmatrix}$$

$$\Delta I_2 = -18(0 - 0) - (-12)(12 \times 4 - 0) + 0.$$

$$\Delta I_2 = -2016$$

$$\Delta I_3 = \begin{vmatrix} + & - & + \\ -18 & 12 & -12 \\ 12 & -23 & 0 \\ 0 & 4 & 0 \end{vmatrix}$$

$$\Delta I_3 = -18(0 - 0) - 12(0) - 12(12 \times 4 - (0 \times -23))$$

$$\Delta I_3 = -576$$

Solution - Answers.

$$I_1 = \frac{\Delta I_1}{\Delta}$$

$$I_1 = \frac{-3672}{-3492}$$

$$I_1 = 1.051 \text{ Amperes}$$

$$I_2 = \frac{\Delta I_2}{\Delta}$$

$$I_2 = \frac{-2016}{-3492}$$

$$I_2 = 0.577 \text{ Amperes}$$

$$I_3 = \frac{\Delta I_3}{\Delta}$$

$$I_3 = \frac{-576}{-3492}$$

$$I_3 = 0.164 \text{ Amperes}$$

Current through $4\text{-}\Omega$ resistor, $I_{4\text{-}\Omega} = I_2 - I_3$

$$I_{4\text{-}\Omega} = 0.577 - 0.164$$

$$I_{4\text{-}\Omega} = 0.413 \text{ Amperes}$$

- ③. Determine the currents in the 8Ω resistor in the circuit shown in figure using mesh analysis.

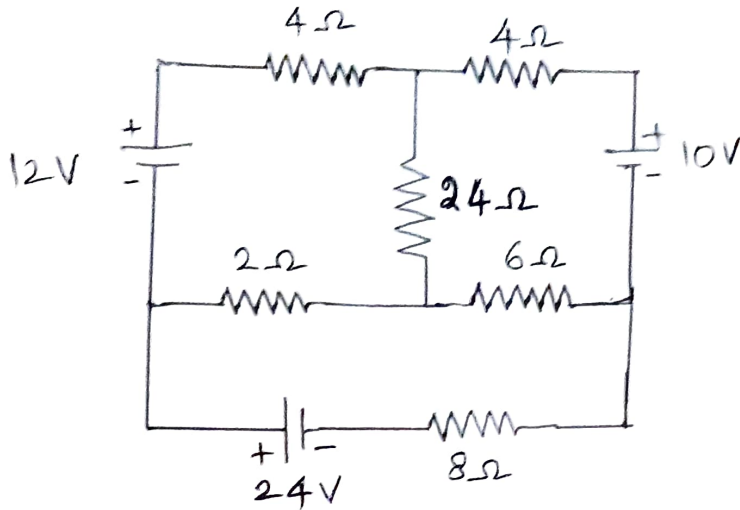

Solution:

* Apply loop numbers 1, 2, 3.

* Apply loop currents I_1, I_2 and I_3 in clockwise direction.

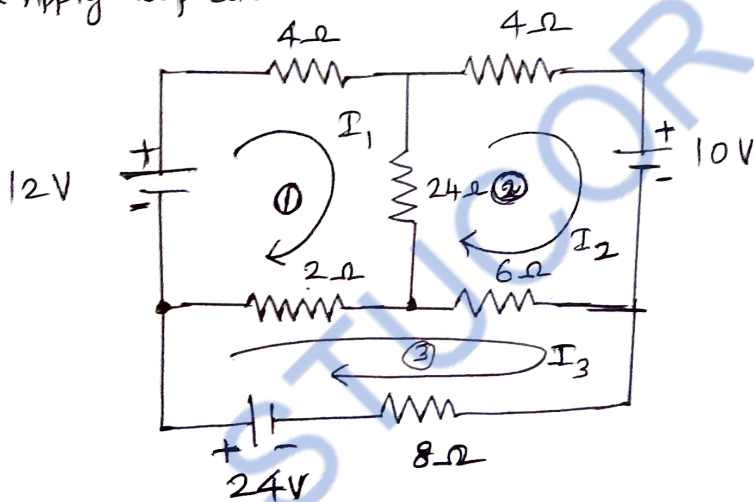

Apply KVL to loop 1,

$$-4I_1 - 24(I_1 - I_2) - 2(I_1 - I_3) + 12 = 0$$

$$-4I_1 - 24I_1 + 24I_2 - 2I_1 + 2I_3 + 12 = 0$$

$$-30I_1 + 24I_2 + 2I_3 = -12 \longrightarrow \textcircled{1}$$

Apply KVL to loop 2,

$$-4I_2 - 10 - 6(I_2 - I_3) - 24(I_2 - I_1) = 0$$

$$-4I_2 - 10 - 6I_2 + 6I_3 - 24I_2 + 24I_1 = 0$$

$$24I_1 - 34I_2 + 6I_3 = 10 \longrightarrow \textcircled{2}$$

$$-2(I_3 - I_1) - 6(I_3 - I_2) - 8I_3 + 24 = 0$$

$$-2I_3 + 2I_1 - 6I_3 + 6I_2 - 8I_3 + 24 = 0$$

$$2I_1 + 6I_2 - 16I_3 = -24 \longrightarrow \textcircled{3}$$

* By using Cramer's rule, we can find the current through the 8Ω resistor.

* As 8Ω resistor is in 3rd loop, hence the current through 8Ω resistor is I_3 .

* To find I_3 , ΔI_3 and Δ had to be found.

$$\begin{bmatrix} -30 & 24 & 2 \\ 24 & -34 & 6 \\ 2 & 6 & -16 \end{bmatrix} \begin{bmatrix} I_1 \\ I_2 \\ I_3 \end{bmatrix} = \begin{bmatrix} -12 \\ 10 \\ -24 \end{bmatrix}$$

$$\Delta = \begin{vmatrix} + & - & + \\ -30 & 24 & 2 \\ 24 & -34 & 6 \\ 2 & 6 & -16 \end{vmatrix}$$

$$\Delta = -30(-34 \times -16 - (6 \times 6)) - 24(24 \times -16 - (6 \times 2)) + 2(24 \times 6 - (-34 \times 2))$$

$$\Delta = -5312$$

$$\Delta I_3 = \begin{vmatrix} + & - & + \\ -30 & 24 & -12 \\ 24 & -34 & 10 \\ 2 & 6 & -24 \end{vmatrix}$$

$$\Delta I_3 = -30(-34 \times -24 - (6 \times 10)) - 24(24 \times -24 - (10 \times 2)) - 12(24 \times 6 - (-34 \times 2))$$

$$\Delta I_3 = -10,920$$

(9)

Thus the current through 8Ω resistor is $I_{8\Omega}$

$$I_{8\Omega} = I_3$$

$$\therefore I_3 = \frac{\Delta I_3}{\Delta}$$

$$I_3 = \frac{-10,920}{-5312}$$

$$I_3 = 2.055 \text{ Amperes}$$

Answer:

Current through 8Ω resistor is 2.055 Amperes.

Problem from KVL:

Consider the circuit shown in figure. Determine the current I . [AV, APRIL/MAY 2022]



To find:

Current I

Solution: Apply KVL to the closed loop

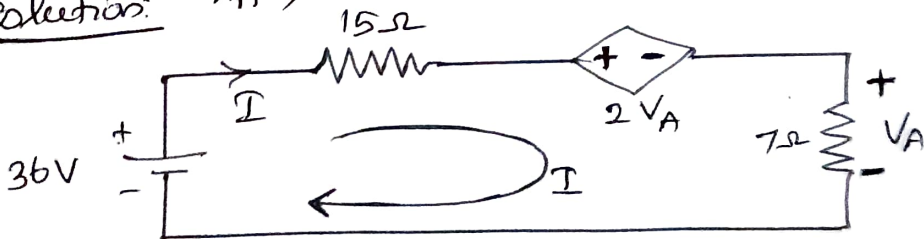

$$-15I - 2V_A - V_A + 36 = 0.$$

Here $V_A = 7I$

$$\therefore -15I - 2(7I) - 7I + 36 = 0$$

$$-15I - 14I - 7I + 36 = 0$$

$$-36I = -36$$

\therefore current is $I = 1 \text{ Amperes}$

Answer

current (I) = 1 Amps

(10)

NODAL ANALYSIS [By using KCL]

Calculate the voltage across 15Ω resistor in the network shown in figure below using Nodal Analysis

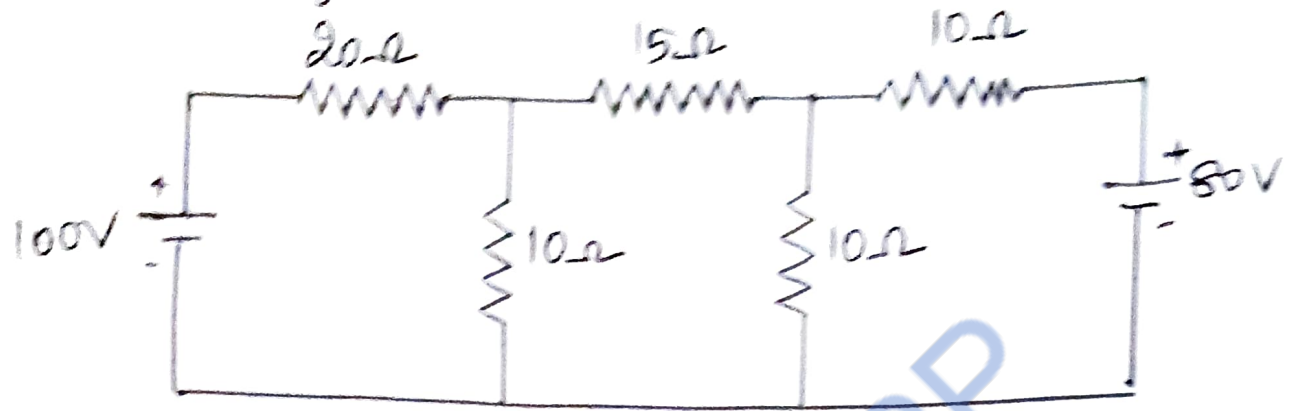

To find:

voltage across 15Ω resistor

Solution:

Convert voltage sources to current sources

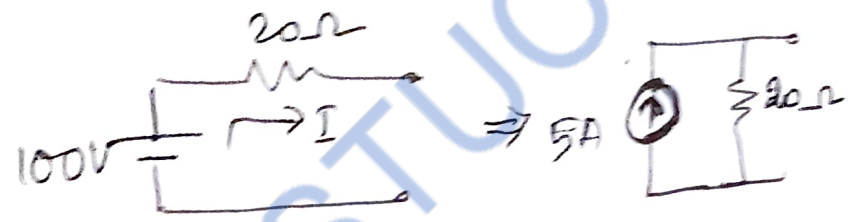

$$I_1 = \frac{V}{R} = \frac{100}{20}$$

$$I_1 = 5A$$

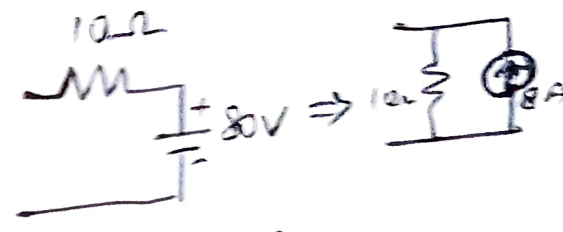

$$I_2 = \frac{V}{R} = \frac{80}{10}$$

$$I_2 = 8 \text{ Amperes}$$

The circuit is changed as

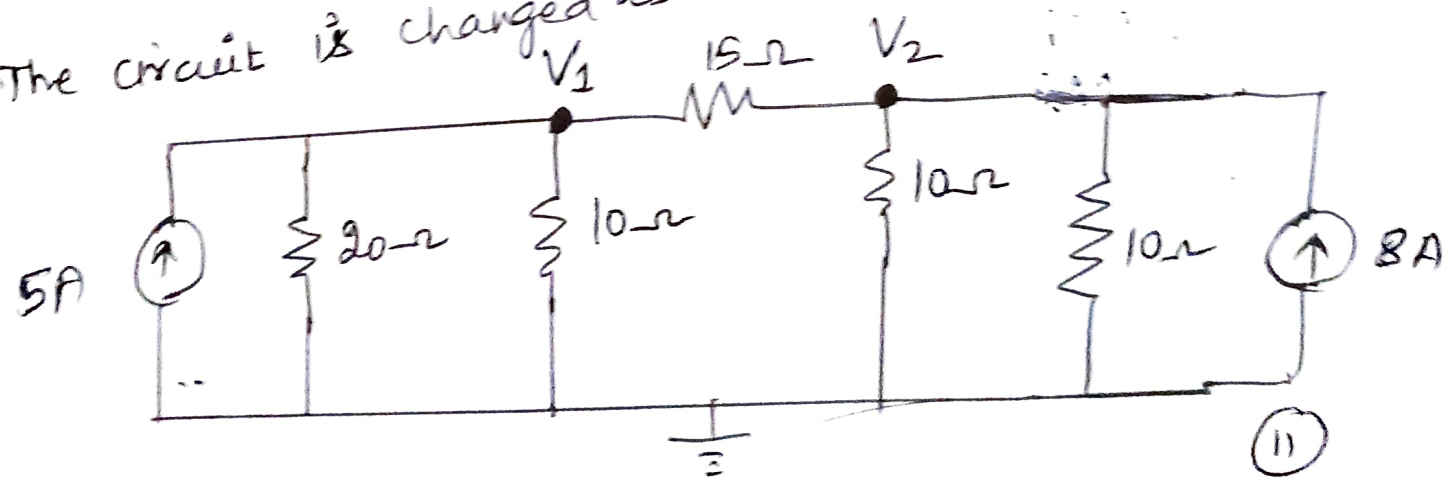

Here 2 nodes are there i.e., V_1 and V_2

By Direct Inspection method.

$$\left[\frac{1}{R} \right] [V] = [I]$$

$$\begin{bmatrix} +\left(\frac{1}{10} + \frac{1}{20} + \frac{1}{15}\right) & -\left(\frac{1}{15}\right) \\ -\left(\frac{1}{15}\right) & +\left(\frac{1}{15} + \frac{1}{10} + \frac{1}{10}\right) \end{bmatrix} \begin{bmatrix} V_1 \\ V_2 \end{bmatrix} = \begin{bmatrix} 5 \\ 8 \end{bmatrix}$$

$$\begin{bmatrix} 0.216 & -0.066 \\ -0.066 & 0.266 \end{bmatrix} \begin{bmatrix} V_1 \\ V_2 \end{bmatrix} = \begin{bmatrix} 5 \\ 8 \end{bmatrix}$$

$$\Delta = \begin{vmatrix} 0.216 & -0.066 \\ -0.066 & 0.266 \end{vmatrix}$$

$$\Delta = 0.216 \times 0.266 - (-0.066 \times -0.066)$$

$$\Delta = 0.053$$

$$\Delta V_1 = \begin{vmatrix} + & - \\ 5 & -0.066 \\ 8 & 0.266 \end{vmatrix}$$

$$\Delta V_1 = 5 \times 0.266 - (-0.066 \times 8)$$

$$\Delta V_1 = 1.858$$

$$\Delta V_2 = \begin{vmatrix} + & - \\ 0.216 & 5 \\ -0.066 & 8 \end{vmatrix}$$

$$\Delta V_2 = 0.216 \times 8 - (5 \times -0.066)$$

$$\Delta V_2 = 2.058$$

Answers :-

① Node Voltages, $V_1 = \frac{\Delta V_1}{\Delta}$

$$V_1 = \frac{1.858}{0.053}$$

$$V_1 = 35.056 \text{ Volts}$$

$$V_2 = \frac{\Delta V_2}{\Delta}$$

$$V_2 = \frac{2.058}{0.053}$$

$$V_2 = 38.830 \text{ Volts}$$

② Current through 15Ω resistor, $I_{15\Omega} = \frac{V_2 - V_1}{15}$

$$I_{15\Omega} = \frac{(38.830 - 35.056)}{15}$$

$$I_{15\Omega} = \frac{3.774}{15}$$

$$I_{15\Omega} = 0.251 \text{ Amperes}$$

③ Voltage across 15Ω resistor, $V_{15} = I_{15} \times 15$

$$V_{15} = 0.251 \times 15$$

$$V_{15} = 3.765 \text{ Volts}$$

② Using nodal voltage analysis, determine the nodal voltages for the circuit shown in the figure.

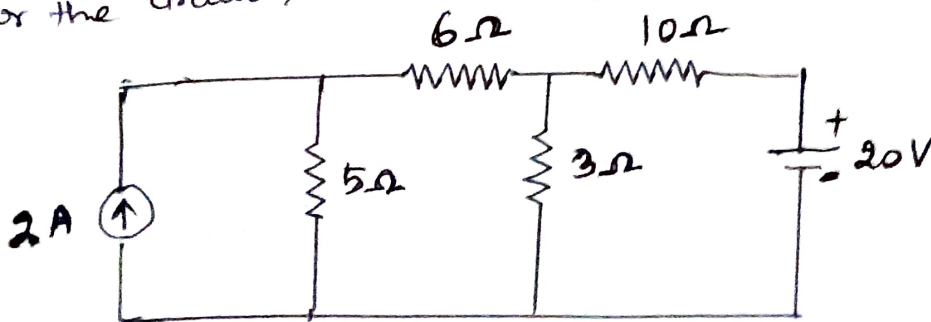

To find:

Nodal Voltages (V_1, V_2).

Solution:

Step 1: Identify the nodes and assign reference.

Step 2: Convert voltage source into current source.

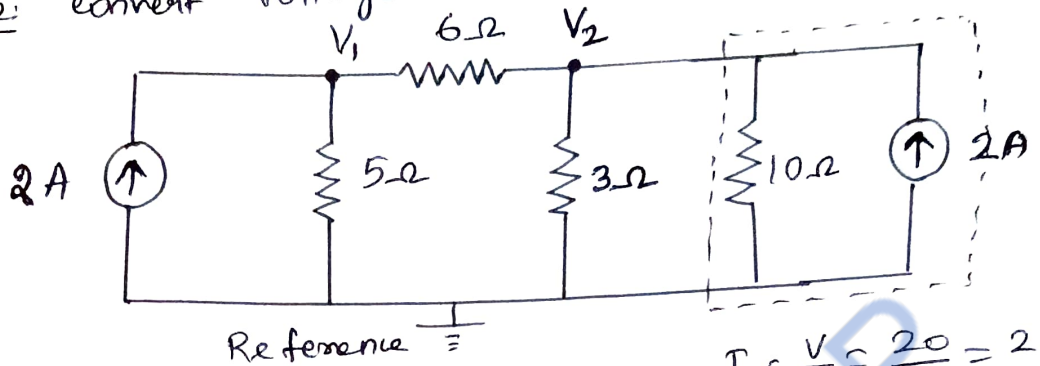

$$I = \frac{V}{R} = \frac{20}{10} = 2A$$

Assuming the nodes, V_1 and V_2 as nodal voltages with a reference.

By direct inspection method,

$$\begin{bmatrix} + \left(\frac{1}{5} + \frac{1}{6} \right) & - \left(\frac{1}{6} \right) \\ - \left(\frac{1}{6} \right) & + \left(\frac{1}{6} + \frac{1}{3} + \frac{1}{10} \right) \end{bmatrix} \begin{bmatrix} V_1 \\ V_2 \end{bmatrix} = \begin{bmatrix} 2 \\ 2 \end{bmatrix}$$

$$\begin{bmatrix} 0.366 & -0.166 \\ -0.166 & 0.6 \end{bmatrix} \begin{bmatrix} V_1 \\ V_2 \end{bmatrix} = \begin{bmatrix} 2 \\ 2 \end{bmatrix}$$

$$\Delta = \begin{vmatrix} 0.366 & -0.166 \\ -0.166 & 0.6 \end{vmatrix}$$

$$\Delta = 0.366 \times 0.6 - (-0.166 \times -0.166)$$

$$\Delta = 0.192$$

$$\Delta V_1 = \begin{vmatrix} + & - \\ 2 & -0.166 \\ 2 & 0.6 \end{vmatrix}$$

$$\Delta V_1 = 2 \times 0.6 - (-0.166 \times 2)$$

$$\Delta V_1 = 1.532$$

$$\Delta V_2 = \begin{vmatrix} + & - \\ 0.366 & 2 \\ -0.166 & 2 \end{vmatrix}$$

$$\Delta V_2 = 0.366 \times 2 - (2 \times -0.166)$$

$$\Delta V_2 = 1.064$$

∴ Nodal Voltages, $V_1 = \frac{\Delta V_1}{\Delta}$

$$V_1 = \frac{1.532}{0.192}$$

$$V_1 = 7.979 \text{ volts}$$

$$V_2 = \frac{\Delta V_2}{\Delta}$$

$$V_2 = \frac{1.064}{0.192}$$

$$V_2 = 5.541 \text{ volts}$$

Answers:

Nodal Voltages,

$$V_1 = 7.979 \text{ volts}$$

$$V_2 = 5.541 \text{ volts}$$

Problems from Series R-L-C circuit.

① In the circuit shown in figure below, determine the total impedance, current I , phase angle ϕ and voltage across the element.

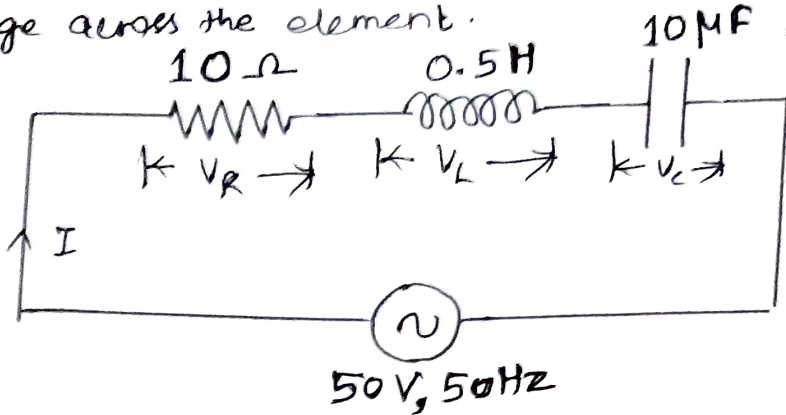

Given:

$$R = 10 \Omega$$

$$L = 0.5 \text{ H}$$

$$C = 10 \text{ MF} = 10 \times 10^{-6} \text{ f}$$

$$V = 50 \text{ V}$$

$$f = 50 \text{ Hz}$$

$$[\because 1 \text{ MF} = 10^{-6} \text{ f}]$$

To find:

- 1) Total impedance (Z)
- 2) current (I)
- 3) phase angle (ϕ)
- 4) voltage across the element

Solution:

1) Total Impedance (Z):

$$Z = R + j(X_L - X_C)$$

$$X_L = 2\pi fL$$

$$X_L = 2 \times \pi \times 50 \times 0.5$$

$$X_L = 157.079 \Omega$$

$$X_C = \frac{1}{(2\pi f C)}$$

$$X_C = \frac{1}{(2 \times \pi \times 50 \times 10 \times 10^{-6})}$$

$$\boxed{X_C = 318.309 \Omega}$$

$$\therefore Z = R + j(X_L - X_C)$$

$$Z = 10 + j(157.079 - 318.309)$$

$$Z = 10 + j(-161.23)$$

$$Z = 10 - j161.23$$

$$\boxed{Z = 161.539 \angle -86.45^\circ}$$

2) Current (I):-

$$I = \frac{V}{Z}$$

$$I = \frac{50}{161.539}$$

$$\boxed{I = 0.309 \text{ Amperes}}$$

3) phase angle (ϕ):

$$\text{From } Z = 161.539 \angle -86.45^\circ$$

$$\therefore \phi = -86.45$$

$$\boxed{\therefore \text{Phase angle, } \phi = -86.45^\circ}$$

4) Voltage across each element:

$$V_R = IR$$

$$V_R = 0.309 \times 10$$

$$\boxed{\therefore V_R = 3.09 \text{ volts}}$$

$$V_L = I \times X_L$$

$$V_L = 0.309 \times 157.079$$

$$V_L = 48.537 \text{ volts}$$

$$V_C = I \times X_C$$

$$V_C = 0.309 \times 318.309$$

$$V_C = 98.357 \text{ volts}$$

Answers:

1) Total Impedance (Z) = $161.539 \angle -86.45^\circ$

2) Current (I) = 0.309 Amperes

3) Phase angle (θ) = -86.45°

4) Voltage across elements

$$V_R = 3.09 \text{ volts}$$

$$V_L = 48.537 \text{ volts}$$

$$V_C = 98.357 \text{ volts.}$$

② In a series RLC circuit, $R = 24 \Omega$, $L = 191 \text{ mH}$, $C = 66.3 \mu\text{F}$ given that the supply voltage is 240 V , 60 Hz , find the following

(i) Inductive reactance

(ii) Capacitive reactance

(iii) Impedance

(iv) Current

(v) Power factor

(vi) Real power

(vii) Reactive power

(viii) Apparent power.

Given:

$$R = 24 \Omega$$

$$L = 191 \text{ mH} = 191 \times 10^{-3} \text{ H}$$

$$[\because 1 \text{ mH} = 10^{-3} \text{ H}]$$

$$C = 66.3 \text{ nF} = 66.3 \times 10^{-6} \text{ F}$$

$$[\because 1 \text{ nF} = 10^{-6} \text{ F}]$$

$$V = 240 \text{ V}$$

$$f = 60 \text{ Hz}$$

Solution

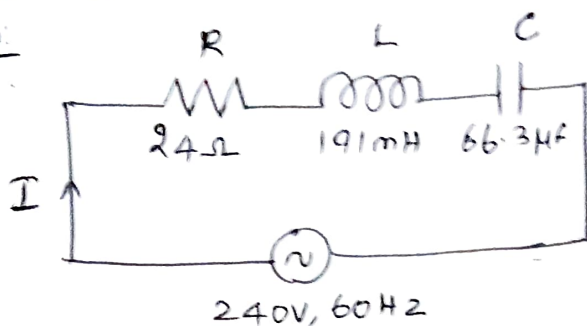

(i) Inductive reactance (X_L):

$$X_L = 2\pi fL$$

$$X_L = 2 \times \pi \times 60 \times 191 \times 10^{-3}$$

$$X_L = 72.005 \Omega$$

(ii) Capacitive reactance (X_C):

$$X_C = \frac{1}{2\pi fC}$$

$$X_C = \frac{1}{(2 \times \pi \times 60 \times 66.3 \times 10^{-6})}$$

$$X_C = 40.008 \Omega$$

(iii) Impedance (Z):

$$Z = R + j(X_L - X_C)$$

$$Z = 24 + j(72.005 - 40.008)$$

$$Z = 24 + j31.997$$

$$Z = 39.997 \angle 53.12^\circ \Omega$$

(iv) Current (I):

$$I = \frac{V}{Z}$$

$$I = \frac{240}{39.997}$$

$$I = 6.000 \text{ Amperes}$$

(v) Power factor (cos θ):

$$\text{Here } Z = 39.997 / 53.12^\circ$$

Phase angle, $\theta = 53.12^\circ$

$$\begin{aligned} \therefore \text{Power factor} &= \cos\theta \\ &= \cos 53.12^\circ \end{aligned}$$

$$\text{Power factor} = \cos\theta = 0.600$$

(vi) Real power (P):

$$P = VI \cos\theta$$

$$P = 240 \times 6.000 \times 0.6$$

$$P = 864 \text{ Watts}$$

(vii) Reactive Power (Q):

$$Q = VI \sin\theta$$

$$Q = 240 \times 6 \times \sin 53.12^\circ$$

$$Q = 1151.847 \text{ VAR}$$

(viii) Apparent Power (S):

$$S = VI$$

$$S = 240 \times 6$$

$$S = 1,440 \text{ VA}$$

Answers:

1) $X_L = 72.005 \Omega$

2) $X_C = 40.008 \Omega$

3) $Z = 39.997 / 53.12^\circ$

4) $I = 6 \text{ Amperes}$

5) $\cos\theta = 0.6$

6) $P = 864 \text{ Watts}$

7) $Q = 1151.847 \text{ VAR}$

8) $S = 1,440 \text{ VA}$

Problems from average value, R.M.S value and Form factor of a sine wave.

①. Find the form factor of the half wave rectified sine wave shown in figure. [AV, APR/MAY 2022]

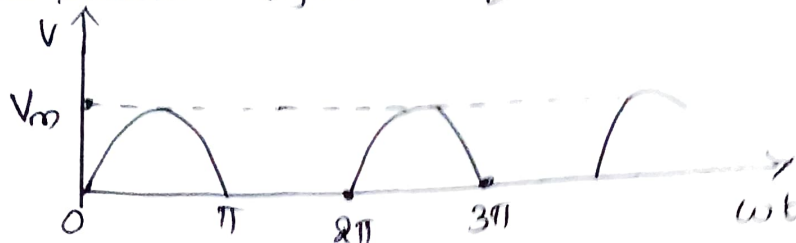

[4 PA]

To find:

$$\text{Form factor} = \frac{\text{R.M.S Value}}{\text{Average Value}}$$

In order to find form factor, R.M.S value and average value had to be found.

Step 1: To find average value:

* Period is "T" seconds (2π radians) as the wave is unsymmetrical.

$$I_{av} = \frac{1}{T} \int_0^T i dt$$

(∵ T = 2π)

$$I_{av} = \frac{1}{2\pi} \int_0^{2\pi} I_m \sin \theta d\theta$$

[∵ i = I_m sin θ]

$$I_{av} = \frac{1}{2\pi} \left[\int_0^{\pi} I_m \sin \theta d\theta + \int_{\pi}^{2\pi} 0 d\theta \right]$$

$$I_{av} = \frac{1}{2\pi} \int_0^{\pi} I_m \sin \theta d\theta$$

[∵ ∫_π^{2π} 0 dθ = 0]

$$I_{av} = \frac{I_m}{2\pi} \int_0^{\pi} \sin \theta d\theta$$

(2)

$$I_{av} = \frac{I_m}{2\pi} \left[-\cos\theta \right]_0^\pi \quad \left[\int \sin\theta d\theta = -\cos\theta \right]$$

$$I_{av} = \frac{I_m}{2\pi} \left[-\cos(\pi) - (-\cos 0) \right] \quad \left[\begin{array}{l} \because \cos\pi = -1 \\ \because \cos 0 = 1 \end{array} \right]$$

$$I_{av} = \frac{I_m}{2\pi} \left[-(-1) - (-1) \right]$$

$$I_{av} = \frac{I_m}{2\pi} (2)$$

$$I_{av} = \frac{I_m}{\pi} \quad (\text{or}) \quad I_{av} = 0.318 I_m$$

Step 2: To find R.M.S value

$$I_{RMS} = \sqrt{\frac{1}{2\pi} \int_0^{2\pi} (I_m \sin\theta)^2 d\theta}$$

$$I_{RMS} = \sqrt{\frac{1}{2\pi} \int_0^{2\pi} I_m^2 \sin^2\theta d\theta}$$

$$I_{RMS} = \sqrt{\frac{I_m^2}{2\pi} \int_0^{2\pi} \sin^2\theta d\theta}$$

$$\left[\because \sin^2\theta = \frac{1 - \cos 2\theta}{2} \right]$$

$$I_{RMS} = \sqrt{\frac{I_m^2}{2\pi} \int_0^{2\pi} \left(\frac{1 - \cos 2\theta}{2} \right) d\theta}$$

$$I_{RMS} = \sqrt{\frac{I_m^2}{4\pi} \int_0^{2\pi} (1 - \cos 2\theta) d\theta}$$

$$I_{RMS} = \sqrt{\frac{I_m^2}{4\pi} \left[\int_0^\pi (1 - \cos 2\theta) d\theta + \int_\pi^{2\pi} (1 - \cos 2\theta) d\theta \right]}$$

$$I_{RMS} = \sqrt{\frac{I_m^2}{4\pi} \left[\int_0^\pi (1 - \cos 2\theta) d\theta + 0 \right]} \quad \left[\because \int_0^{2\pi} (1 - \cos 2\theta) d\theta = 0 \right]$$

$$I_{RMS} = \sqrt{\frac{I_m^2}{4\pi} \left[0 - \frac{\sin 2\theta}{2} \right]_0^\pi}$$

$$I_{RMS} = \sqrt{\frac{I_m^2}{4\pi} \left[(\pi - 0) - \left(\frac{\sin 2\pi}{2} - \frac{\sin 2(0)}{2} \right) \right]}$$

$$I_{RMS} = \sqrt{\frac{I_m^2}{4\pi} (\pi)}$$

$$\left[\because \sin 2\pi = 0 \right]$$

$$\left[\because \sin 0 = 0 \right]$$

$$I_{RMS} = \sqrt{\frac{I_m^2}{4}}$$

$$I_{RMS} = \frac{\sqrt{I_m^2}}{\sqrt{4}}$$

$$I_{RMS} = \frac{I_m}{2}$$

$$(or) \quad I_{RMS} = 0.5 I_m$$

FRA

$$\therefore \text{Form factor} = \frac{\text{R.M.S Value}}{\text{Average value}}$$

$$\text{Form factor} = \frac{0.5 I_m}{0.318 I_m}$$

$$\text{Form factor} = 1.572$$

(23)

Steady State Analysis of RLC Circuit.

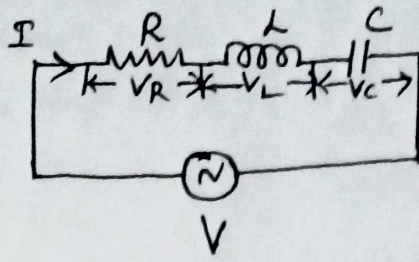

$$V = V_m \sin \omega t.$$

$$V = IZ$$

$$V = V_R + V_L + V_C$$

$$V_R = IR \quad \begin{array}{c} \longrightarrow \\ V_R \quad I \end{array}$$

$$V_L = jI X_L \quad \begin{array}{c} \uparrow V_L \\ \square 90^\circ \\ \longrightarrow I \end{array}$$

$$V_C = -jIX_C \quad \begin{array}{c} \square 90^\circ \\ \downarrow V_C \\ \longrightarrow I \end{array}$$

$$V = IR + jX_L I - jIX_C$$

$$IZ = I(R + j(X_L - X_C))$$

$$Z = R + j(X_L - X_C)$$

$$|Z| = \sqrt{R^2 + (X_L - X_C)^2}; \quad \phi = \tan^{-1}\left(\frac{X_L - X_C}{R}\right)$$

Case: 1 $X_L = X_C$.

$V_L = V_C$ and cancel each other. $\therefore V = V_R$.

Circuit is resistive (I & V are in phase)

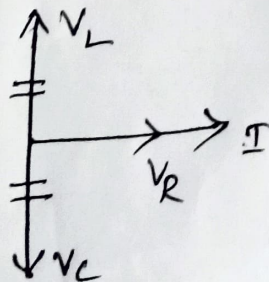

Case 2: $X_L > X_C$.

$$V_L > V_C$$

$$V^2 = V_R^2 + (V_L - V_C)^2$$

$$V = \sqrt{(V_R)^2 + (V_L - V_C)^2}$$

$$V = \sqrt{(IR)^2 + (IX_L - IX_C)^2}$$

$$V = I \sqrt{R^2 + (X_L - X_C)^2}$$

$$Z = \frac{V}{I} = \sqrt{R^2 + (X_L - X_C)^2} ; \phi = \tan^{-1} \frac{X_L - X_C}{R}$$

Circuit is inductive (I lag V).

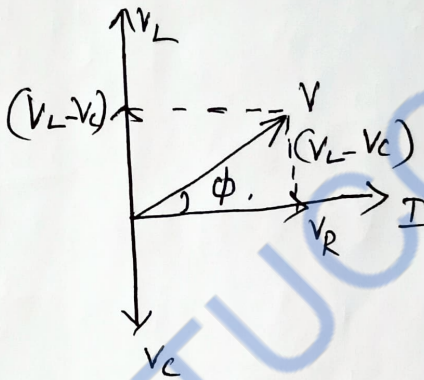

Case 3: $X_C > X_L$

$$V_C > V_L$$

$$V^2 = V_R^2 + (V_C - V_L)^2$$

$$V = \sqrt{(IR)^2 + (IX_C - IX_L)^2}$$

$$V = I \sqrt{R^2 + (X_C - X_L)^2}$$

$$Z = \frac{V}{I} = \sqrt{R^2 + (X_C - X_L)^2}$$

$$\phi = \tan^{-1} \left(\frac{X_C - X_L}{R} \right)$$

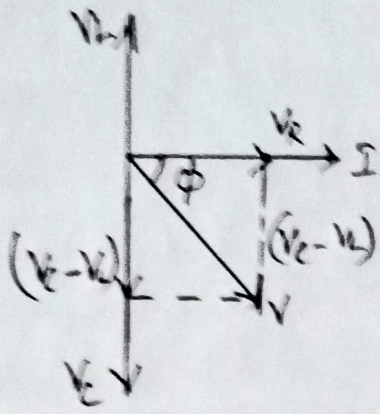

Circuit is capacitive (I lead V)

STUCOR APP

1. Define current

The rate of flow of electrons is called current.

Denoted by letter 'I'

$$current = \frac{charge}{Time} = \frac{Q}{t}$$

$$unit = Ampere (or) \frac{coulomb}{second}$$

2. Define voltage (or) potential difference

Voltage is defined as potential difference between two points in an electric circuit.

$$unit = Volt$$

3. Define Resistance

The opposition offered to the flow of electric current is called resistance.

$$unit = ohm(\Omega)$$

4. Define Electric power

Power is defined as the product of voltage and current.

$$P = VI \quad \quad \quad unit = watts$$

5. Define Energy

Energy is the capacity to do work.

$$Energy = power \times time \quad \quad W = VI \times t$$

$$Unit = watt sec(or) Joules$$

6. Define conductor

The material which allow electric current to pass through it is called conductor.

7. Define Resistor

Resistor is an electrical component made from the material which opposes the flow of current.

8. Define Inductor

Inductor is an element which store energy in the form of electromagnetic field.



$$Unit\ of\ inductance = Henry (H)$$

9. Define Capacitor

Capacitor is a storage element which store and deliver energy in an electric field.



$$Unit\ of\ capacitance = Farad (F)$$

10. State Ohm's law

At constant temperature, the current flowing through a conductor is directly proportional to the potential difference across the conductor.

$$V \propto I$$

$$V = IR$$

R- Resistance (ie) proportionality constant

V- Voltage in volt

I – Current in Ampere

11. State the limitations of Ohm's law

- (i) It is applicable to metallic conductors at constant temperature. If the temperature changes the law is not applicable.
- (ii) It is not applicable to nonlinear devices such as zener diode, vacuum tubes.
- (iii) It is not applicable to non metallic conductors

12. Write the formulas for DC power

$$P = VI = \frac{V^2}{R} = I^2R$$

13. State Kirchoff Current Law (KCL)

The algebraic sum of the current flowing towards a junction is equal to the algebraic sum of the current flowing away from the junction.

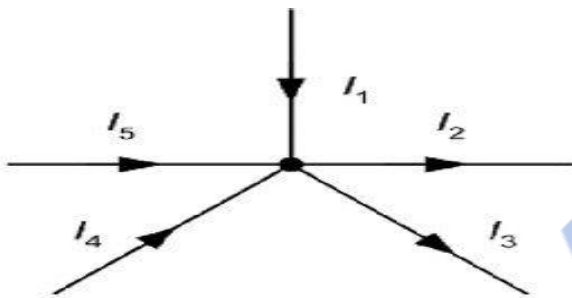

$$I_1 + I_4 + I_5 = I_2 + I_3$$

Current flowing towards junction A = Current flowing away from the junction A

14. State Kirchoff Voltage Law (KVL)

In a closed circuit, the algebraic sum of the potential drop is equal to the algebraic sum of the potential rises.

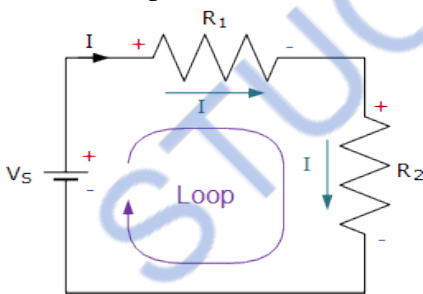

$$\text{Algebraic sum of potential drop} = IR_1 + IR_2$$

$$\text{Algebraic sum of potential rise} = Vs$$

$$Vs = IR_1 + IR_2$$

15. Define the terms Loop and Mesh

The closed path of a network is called a **Loop**

Mesh is a closed path that does not contain any other loop within it

16. Define the terms Node and Junction

A **node** is a point in the network where two or more circuit elements are connected.

A **junction** is a point in the network where three or more circuit elements are connected.

UNIT2-ELECTRICAL MACHINES

1. Explain the construction of D.C Generator/ D.C Motor/ D.C machine

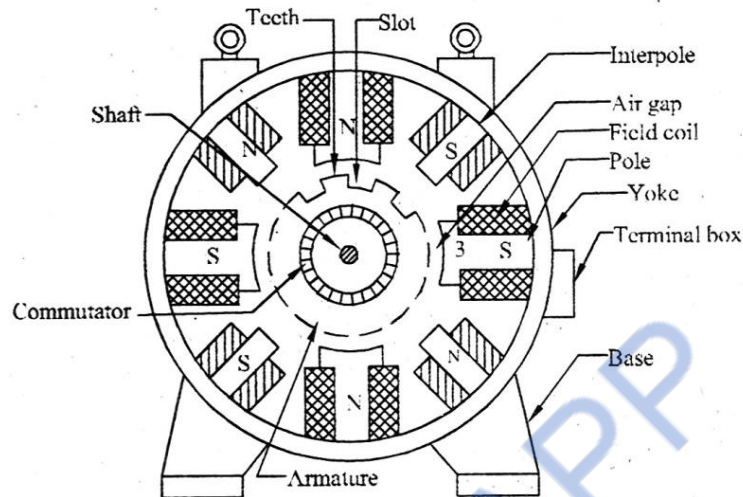

The parts of the D.C. Generator/ motor/ machine are explained in detail as follows:

i) **Yoke or magnetic frame:**

- Provides mechanical support and acts as a cover
- Forms part of the magnetic circuit
- Made of cast iron (smaller machine) or fabricated steel (larger machines)
- For smaller machine, yoke is a single piece
- For large machines, poles are separately made and fitted together

ii) **Magnetic Poles:**

- Consists of pole core and pole shoes
- Spread out flux in air gap
- Support the field coils
- Made of thin laminations of steel
- Cores are laminated to reduce eddy current loss

iii) **Field Coils**

- Wound using enameled copper wire
- Provision is made for insulation and ventilation
- North and South Pole depend on direction of current flow through the coil.

iv) **Inter poles or Commutating poles**

- Improves commutation
- Reduces armature reaction

v) **Armature**

- Attached to machine shaft and rotates between field coils
- Consists of slotted steel laminations
- Laminations insulated from each other by varnish
- Laminations done to reduce eddy current loss
- Armature is wound in two ways:

1. Lap winding
 2. Wave winding
- Ventilation is provided to reduce heat.
- vi) Commutator:**
- Converts A.C into D.C
 - Made of copper segments insulated from each other
- vii) Brushes:**
- Made of carbon
 - Kept inside brush holders
 - Carry current to the load
- viii) Bearings and End cover**
- End cover is made of cast iron or fabricated steel
 - Bearings and end covers are fitted inside the yoke

2. Explain the principle of operation of D.C Generator

- A generator is a machine that converts mechanical energy into electrical energy.
- Works on the principle of Faraday's laws of Electromagnetic Induction.
- When conductor cuts magnetic flux, EMF is induced.
- Current flows through the circuit.

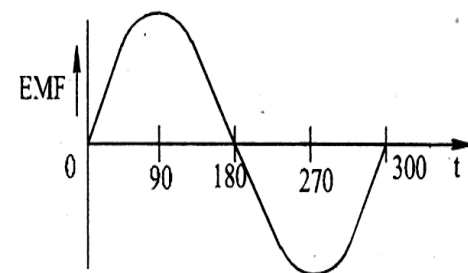
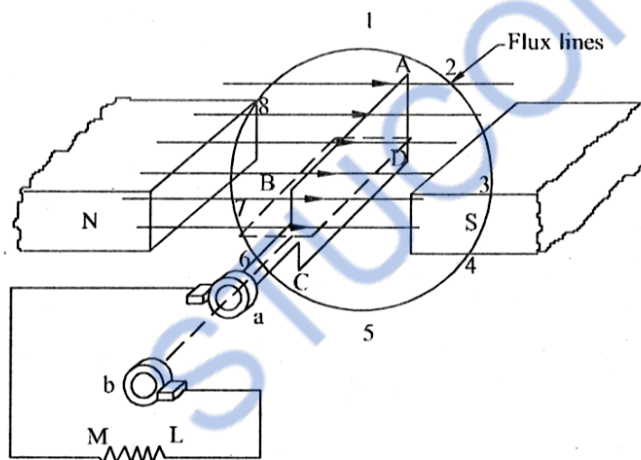

Construction:

- Figure shows a copper coil ABCD moving in a magnetic field
 - Two ends of the coil are joined to the slip rings, 'a' and 'b'.
 - Slip rings 'a' and 'b' are insulated from each other
 - There are two collecting brushes that supply current to External load
- Important components of a generator are:

- i) A Magnetic Field
- ii) Conductor(group of conductors)
- iii) Motion of conductor with respect to Magnetic field

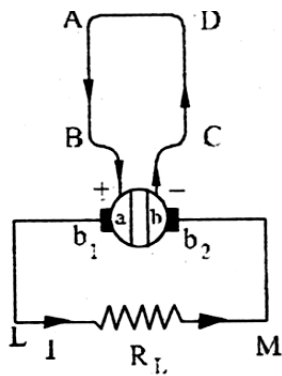

(a)

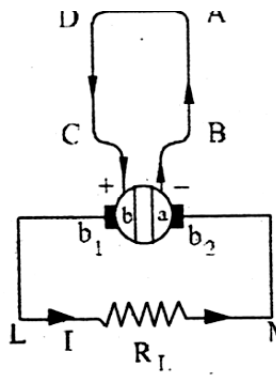

(b)

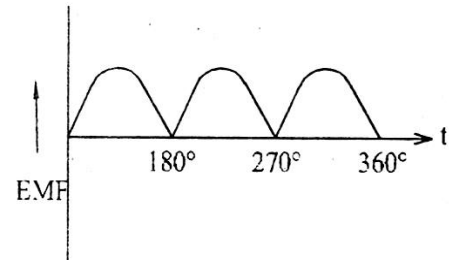

Working:

- Stationary magnetic field is produced by field magnet.
- Armature rotated by a prime mover.
- Prime mover may be a turbine or diesel engine or petrol engine.
- A.C EMF is induced
- Commutator converts A.C into D.C.
- Coil rotated inside magnetic field, flux linkage changes.
- Rate of change of flux linkage is proportional to the induced EMF
- Coil rotates in clockwise direction.

Position of the coil	θ (in degrees)	Flux linked with the coil	EMF=Rate of change of flux linkages
Position '1'	0	Maximum	Minimum
Position '3'	90	Minimum	Maximum
Position '3' - '5'	90 to 180	Gradually increases	Decreases
Position '5' - '7'	180 to 270	Minimum	Maximum
Position '7' - '1'	270 to 360	Gradually increases	Decreases

- EMF induced is alternating EMF.
- Slip rings are replaced by split rings to convert A.C into D.C.

- At first half cycle current flowing through ABLMCD.
- At first half cycle current flowing through DCLMBA.
- The current through load LM is same in both the direction.
- The emf induced is DC

3. State the Fleming's right hand rule.

Fleming's right hand rule:

Keep the thumb finger, fore finger and middle finger of the right hand mutually perpendicular to each other. If the thumb points the direction of motion of the conductor, the fore finger points the direction of flux lines then the middle finger points the direction of induced emf or current.

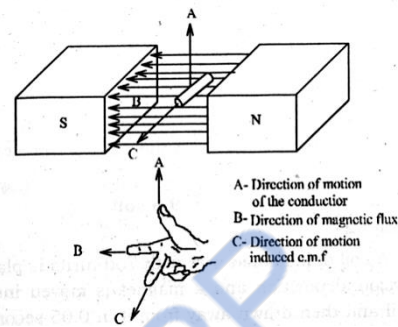

4. State Faraday's laws of electromagnetic induction

Statement:

First Law : It states that flux linking a conductor changes, an emf is induced in it.

Second Law: The magnitude of the induced emf in a coil is equal to the rate of change of flux linkages.

5. List out the types of DC generator and draw the connection diagrams.

Types of DC Generator:

DC generators are classified based on their method of excitation. So on this basis there are two types of DC generators:-

1. Separately excited DC generator

2. Self excited DC generator

Self excited DC generator can again be classified as

- **DC Series generator**
- **DC Shunt generator**
- **DC Compound generator.**

Compound wound generators can again be classified as

- i) **Short Shunt Compound DC Generator**
- ii) **Long Shunt Compound DC Generator**

1. Separately Excited Generator

A field winding is excited using a separate voltage source is called separately excited generator

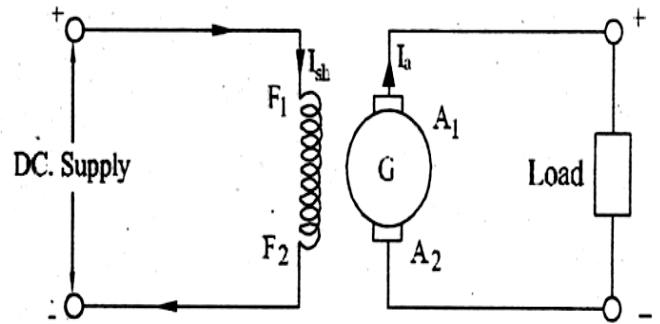

2. Self Excited Generator:

The field winding is excited by the output of the generator itself is called self excited generator. there are three types of self excited dc generators

1) Series 2) Shunt 3) Compound.

A series DC generator in which the armature winding is connected in series with the field winding. Field winding is a low resistance, thick wire of few turns.

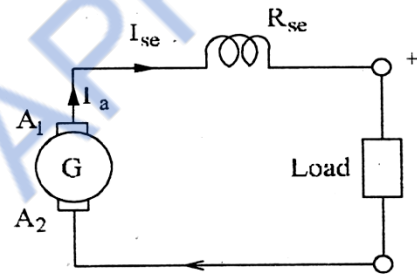

A shunt DC generator in which the field winding is connected in parallel to armature winding. Field winding is a high resistance, thin wire of more turns.

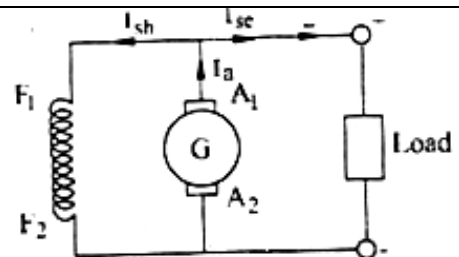

A **compound generator** has two field windings namely shunt winding (R_{sh}) and series winding (R_{se}). They are two types - 1) **Short shunt** 2) **Long shunt**

Short shunt:-

Here the shunt field winding is in parallel with armature winding.

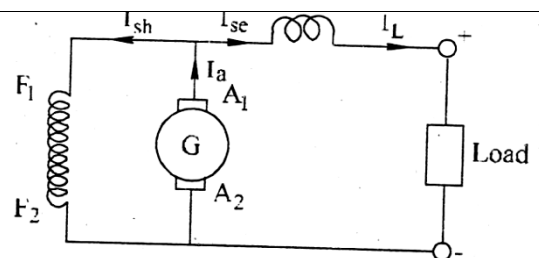

Long shunt:-

Here the shunt field winding is in parallel with both armature and series field winding.

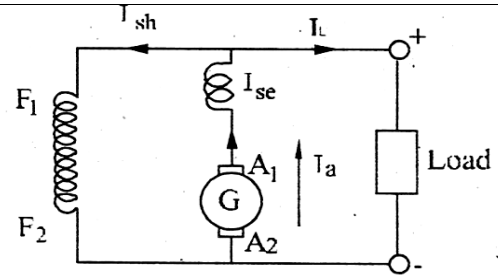
**6. Derive the emf equation of the DC generator.**

Φ = flux per pole

P = Number of poles

Z = Total number of armature conductors

A = Number of parallel path

N = Speed in rpm

Average emf generated per conductor / per revolution = e volts

According to faraday's law,

$$e = \frac{d\Phi}{dt} \text{ volts}$$

'd Φ ' is the flux cut by the conductor in one revolution = P Φ Wb

'dt' is the time taken by the conductor for one revolution = $\frac{60}{N}$ sec

$$e = \frac{d\Phi}{dt} = \frac{P\Phi}{\frac{60}{N}} = \frac{P\Phi N}{60} \text{ volts}$$

The number of conductor in each parallel path = $\frac{Z}{A}$

The emf induced in a DC generator (E_g) = emf induced in each conductor \times the no. of conductor in each parallel path

$$E_g = \frac{P\Phi NZ}{60A} \text{ volts}$$

$$E_g = \frac{\Phi NZ}{60} v \quad (A = P \text{ for lap winding})$$

$$E_g = \frac{P\Phi NZ}{120} v \quad (A = 2 \text{ for Wave winding})$$

7. What are the applications of DC Generator?

Applications of self excited DC Generator:

Series Generator	Shunt generator	Compound generator
<ol style="list-style-type: none"> 1. Boosters 2. for lighting arc lamps 	<ol style="list-style-type: none"> 1. Electroplating 2. Battery Charging 3. lighting loads 4. Excitation of alternators 	<ol style="list-style-type: none"> 1. Differential compound generators are used for DC welding machines. 2. Flat compound generators are used to supply power of offices, hostels and lodges and etc. 3. Over compound generator are used to compensate the voltage drop in feeders.

Applications of separately excited DC Generator:

- Supply source for motors where speed has to be controlled.
- Used where, wide range of DC voltage required for testing purpose

8. State the Fleming's left hand rule.

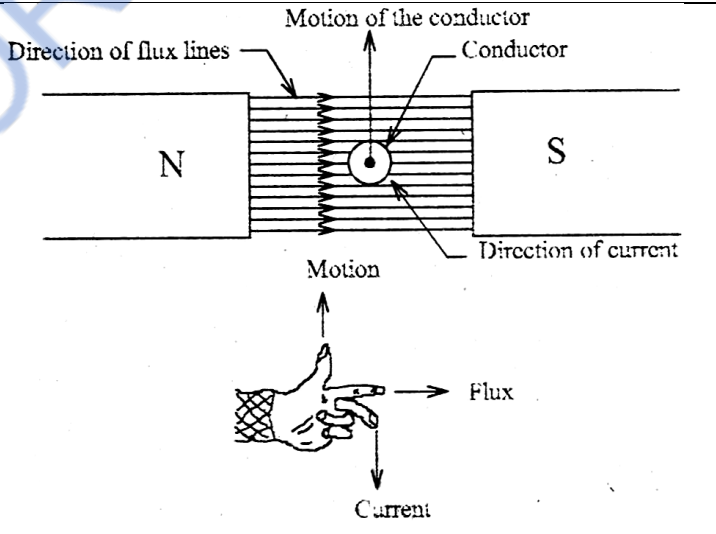
<p>Fleming's left hand rule:</p> <p>Keep the thumb finger, first finger and middle finger of the left hand mutually perpendicular to each other. If the thumb points the direction of force acting on the conductor, the first finger points the direction of field then the middle finger points the direction of current flowing through the conductor</p>	 <p>The diagram illustrates the Fleming's left hand rule. It shows a conductor placed between the North (N) and South (S) poles of a magnet. The direction of flux lines is from the North pole to the South pole. The conductor is shown moving upwards, indicated by an arrow labeled 'Motion of the conductor'. An arrow labeled 'Direction of current' points into the page, indicating the current is flowing away from the viewer. Below the diagram is a hand diagram showing the left hand with the thumb pointing up (Motion), the index finger pointing right (Flux), and the middle finger pointing down (Current).</p>
---	--

9. Explain the types of DC motor and explain with suitable diagrams, the voltage equation of DC motors.

(i) DC Shunt motor:

When the field winding is connected in parallel with the armature winding then it is known as a DC shunt motor.

$$I_a = I_L - I_{sh}$$

$$V = E_b + I_a R_a$$

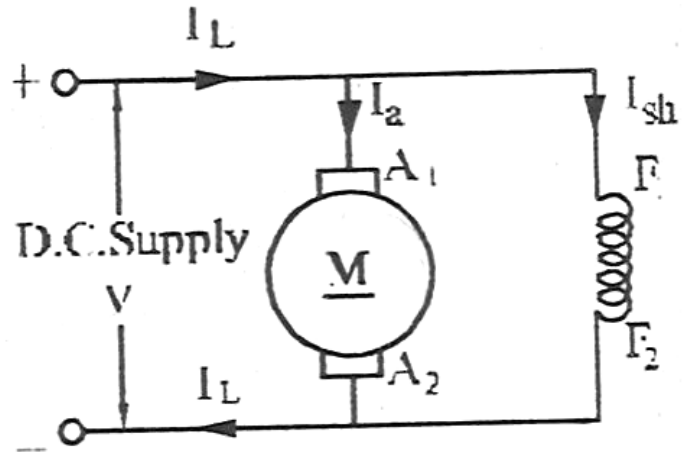

(ii) DC Series motor:

When the field winding is connected in series

with the armature winding then

it is known as a DC series motor.

$$I_a = I_L = I_{sh}$$

$$V = E_b + I_a R_a + I_{re} R_{se}$$

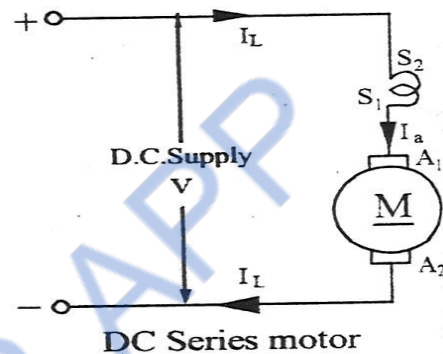

iii) DC Compound motor:

(a) Long shunt compound motor

When a shunt field winding is connected in parallel with the series combination of series field winding and armature winding and this arrangement is connected across the supply. It is called long shunt compound motor.

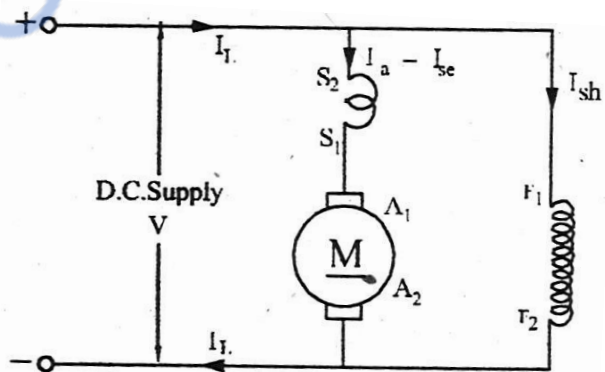

(b) **Short shunt compound motor**

If the shunt field winding is connected only across the armature winding, it is called short shunt compound motor.

$$V = E_b + I_a R_a + I_{Re} R_{Se}$$

$$I_a = I_L - I_{Sh}$$

For long shunt $I_a = I_{Se}$

For short shunt $I_L = I_{Se}$

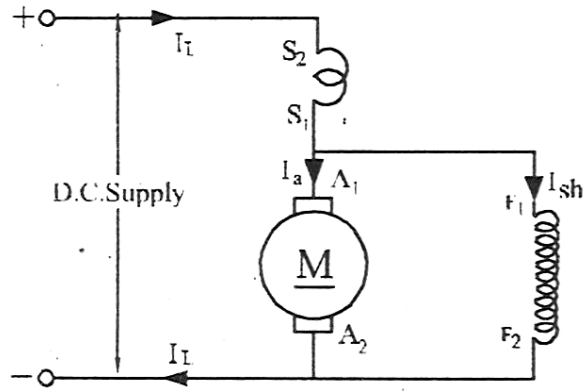

Short shunt DC compound motor

10 . Derive the torque equation of DC motor.

Torque is the turning moment of a force about an axis and is measured by the product of force (F) and radius (r) at right angle to which force acts.

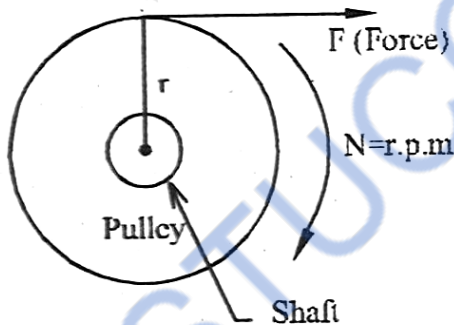

i.e., $T = F \times r$ Newton
re

Where,

$T =$ Torque in Newton
er.

$F =$ Force in Newton
er.

$r =$ radius in
meter

Electrical power is developed by the motor $= E_b I_a$ ----- 1

Mechanical power is developed by the motor $= \frac{2\pi NT}{60}$ ----- 2

In a motor, electrical energy is converted to mechanical energy. So, Equate 1

& 2

$$E_b I_a = \frac{2\pi N T_a}{60}$$

$$T_a = \frac{E_b I_a 60}{2\pi N} \text{ ----- 3}$$

We know

$$E_b = \frac{P\Phi ZN}{60A} \quad \text{-----} \quad 4$$

Substitute, equation 4 in equation 1E

$$T_a = \frac{P\Phi ZN I_a 60}{60A2\pi N}$$

$$T_a = \frac{P\Phi Z I_a}{2\pi A}$$

$$T_a = 0.159P\Phi Z \frac{I_a}{A} \quad \text{N.M} \quad \text{-----} \quad 5$$

The torque should be expressed in terms of kilogram meter. 1Kg = 9.81 Newtons

$$T_a = 0.0162P\Phi Z \frac{I_a}{A} \quad \text{kgm}$$

11. What are the applications of DC motor?

Types of Motor	Applications
Shunt Motor	Centrifugal pumps, light machine tools, reciprocating pumps, wood working machine, paper mills, drilling machines.
Series Motor	Trains, cranes, lifts and conveyors.
Cumulative Compound Motor	Rolling mills, presser, printing machine, punches, shears, conveyors.

12. Explain with neat sketch, the principle of operation of DC Motor. How the direction of rotation is reversed?

- DC motor converts electrical energy into mechanical energy
- When a current carrying conductor is placed in a magnetic field, mechanical force is produced on the conductor.
- Magnitude of force is given by

$$\mathbf{F = BLI \text{ Newton}}$$

where,

F → force produced on the conductor, Newton

B → magnetic flux density, web/m²

L → length of the conductor

I → current flow through the conductor

- Consider a two pole motor

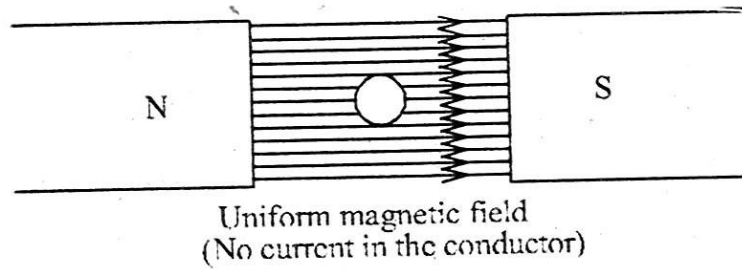

- Figure shows a uniform magnetic field
- No current flow through the conductor.
- Direction of magnetic flux line is from north to south pole
- No movement of the conductor

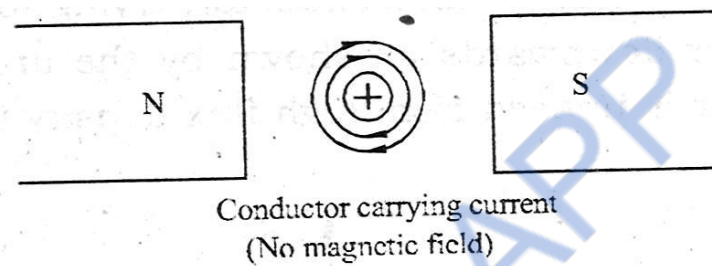

- No exciting current flow through the field winding
- Current is passed through the conductor
- Current flows away from the observer (+)
- Magnetic flux lines produced are in clockwise direction
- No movement of the conductor

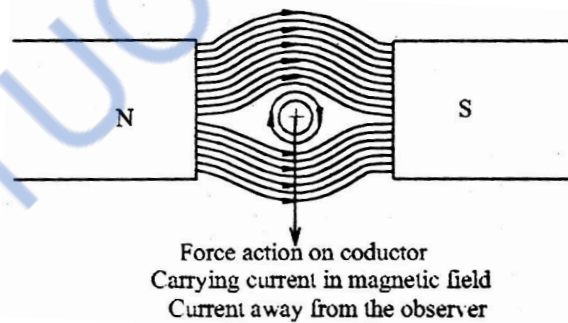

- Current carrying conductor is placed in magnetic field
- Flux is strengthened above the conductor
- Flux is weakened below the conductor
- Conductor is pushed downwards

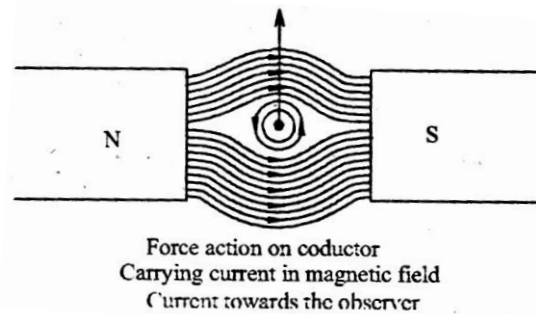

- Current flows towards the observer ()
- Current direction is reversed
- Flux is weakened above the conductor
- Flux is strengthened below the conductor
- Conductor is pushed upwards

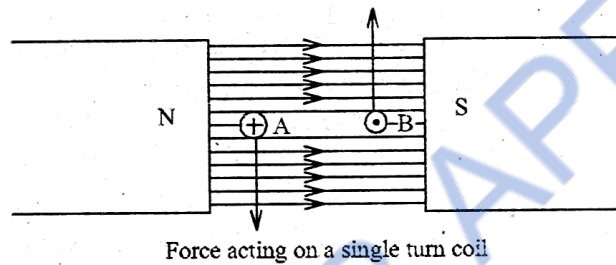

- Consider a current flowing through a single turn coil
- Coil side 'A' moves downwards, Coil side 'B' moves upwards
- Force acting is same in magnitude but opposite in direction
- Coil is wound on armature core and armature will rotate
- Direction of rotation is found out by Fleming's left hand rule

How to change the direction of rotation of motor:

Either by changing the direction of armature current (or) the polarity of the magnetic field.

Explain the constructional details of transformer (or) Explain the construction of core type and shell type transformer.

• Transformer is a static electrical machine which transfer electrical energy from one circuit to another circuit at the same frequency by mutual induction.

• The main components of a transformer are.

- (i) Magnetic core
- (ii) Primary and Secondary windings
- (iii) Insulation of windings
- (iv) Expansion tank or Conservator
- (v) Temperature gauge.
- (vi) Oil gauge.
- (vii) Buchholz relay.
- (viii) Silica gel breather.

Magnetic core.

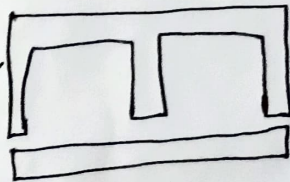
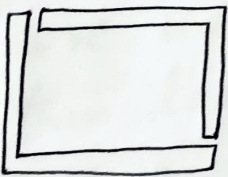

'E' and 'I' stampings.

2 Type Stampings

- Magnetic circuit consists of an iron core
- Transformer core is made up of silicon steel and they are laminated

- The thickness of laminations varies from 0.35 mm to 0.5 mm
- The laminations coated with Varnish and so they are insulated from each other.
- Two types of transformer core are
(i) Core type (ii) Shell type.

(i) Core type transformer

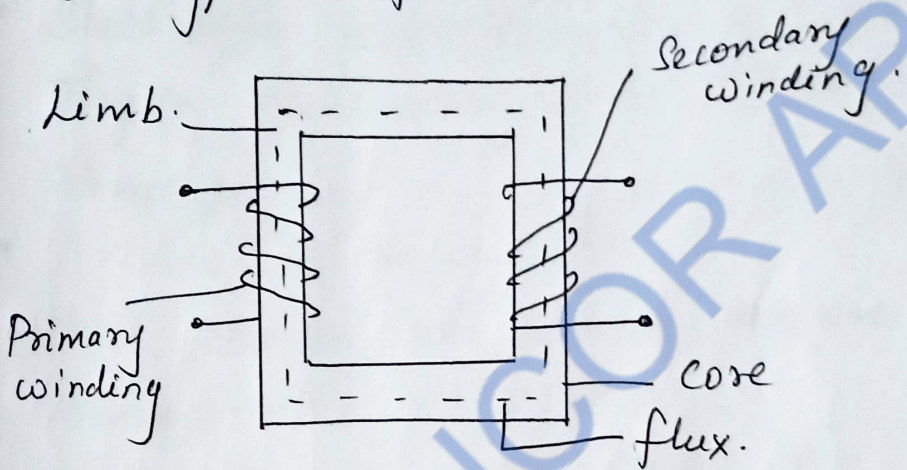

- Core type transformer has two limbs.
- They are made up of 'L' type stampings
- It has only one magnetic path.
- Core is made up of large number of thin laminations
- Both primary and secondary coils are placed on both the limbs.
- The coils used are of cylindrical type.
- Windings surround the core.

(ii) Shell type transformer.

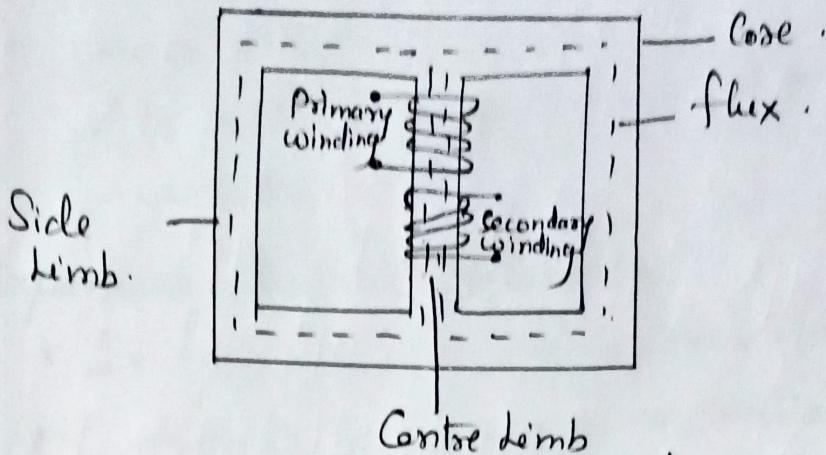

- Shell type transformer has 3 limbs
- They are made up of E and I type stampings
- It has two magnetic paths.
- Both primary and secondary coils are placed on the central limb.
- The coils are of multilayer disc type.
- Core surrounds the winding.
- Primary and secondary windings are made up of copper.

Insulation :

- Paper is used as the basic insulator
- Enamel insulation is used as the inter-turn insulation for low voltage transformers.
- Enameled copper with paper insulation is used for high voltage transformer.

Insulating coil.

- It remove the heat produced in the core and coils.
- Also protects paper from dirt and insulation.

Expansion tank (or) Conservator

- It keep the transformer tank full of oil despite of expansion or contraction of oil with change in temperature.

Temperature Gauge:

- It indicate hot oil (or) hottest spot temperature.

Oil Gauge:

- It indicate oil level present inside the tank.

Buchholz relay:

- It is a gas operated relay
- It give alarm in case of minor fault.
- And disconnect the transformer from the supply in case of severe faults.

Silica gel breather:

It prevent the entry of moisture in the transformer tank.

Working Principle of transformer:

- The transformer works on the principle of electromagnetic induction.

- Transformer is an electrical machine which transfer electrical energy from one circuit to another circuit at the same frequency by mutual induction.

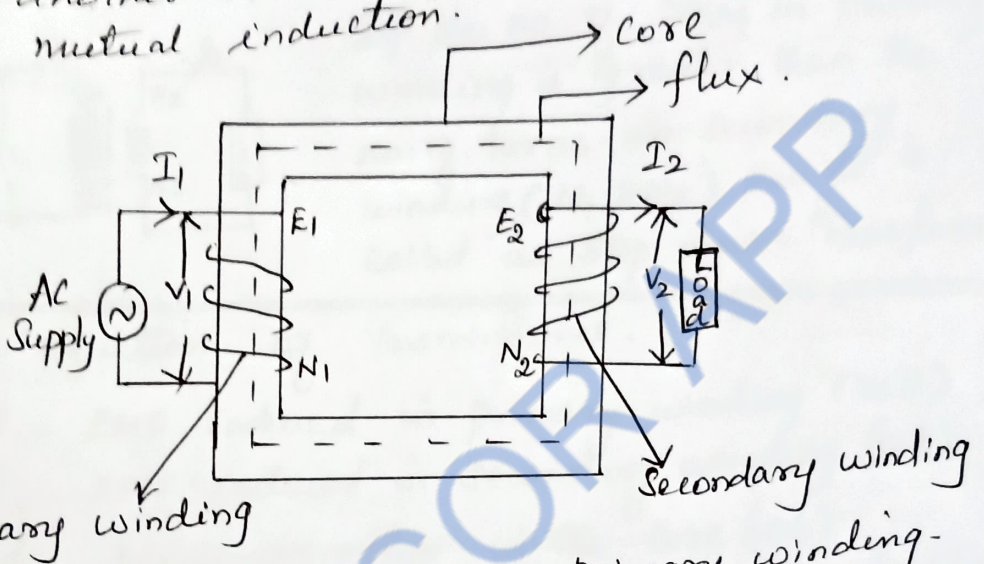

- AC Source is connected to primary winding.
- Exciting current flows through the primary winding.
- Alternating magnetic flux is produced in the core which link both primary and secondary winding.
- By self induction principle, EMF is induced in the primary winding (E_1).
- By mutual induction principle, EMF is induced in the secondary winding (E_2).
- If load is connected in the secondary circuit, current flows through the secondary winding.
- The magnitude of emf induced in secondary winding depend upon the no. of turns.
- N_1 - No. of turns in primary winding.
- N_2 - No. of turns in secondary winding.

Step up transformer:

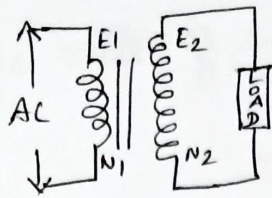

If the no. of turns in secondary winding is greater than the no. of turns in primary winding ($N_2 > N_1$), then it is called as step up transformer.

Step down transformer:

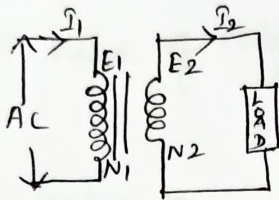

If the no. of turns in primary winding is greater than the no. of turns in secondary winding ($N_1 > N_2$) then it is called as step down transformer.

EMF equation of Transformer:

- E_1 - EMF induced in primary winding (volt)
- E_2 - EMF induced in secondary winding (volt)
- ϕ_m - Maximum flux in the core (wb)
- B_m - Maximum flux density in the core (wb/m^2)
- I_1 - full load primary current
- I_2 - full load secondary current
- N_1 - No. of turns in primary winding.
- N_2 - No. of turns in secondary winding
- A - Area of the core in m^2
- F - Frequency of AC supply.

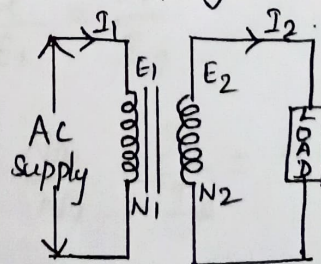
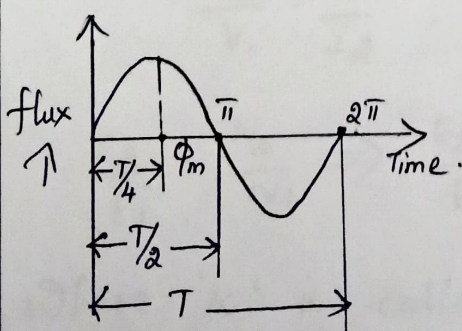

- At time " $T/4$ " sec, flux is maximum (ϕ_m)
- WKT $T = \frac{1}{f}$

According to Faraday's law of electromagnetic induction

$$\begin{aligned} \text{Average rate of change of flux} &= \frac{\phi_m \omega \text{wb/sec}}{\frac{1}{4}f} \\ &= \phi_m \times \frac{4f}{1} = 4f \phi_m \dots \text{VOLT} \end{aligned}$$

$$\text{Form factor} = \frac{\text{RMS}}{\text{Average Value}} = 1.11.$$

$$\begin{aligned} \text{RMS Value of emf induced/turn} &= 1.11 \times 4f \phi_m \\ &= 4.44 f \phi_m \end{aligned}$$

RMS Value of emf induced in p_y wdg

$$E_1 = 4.44 f \phi_m N_1$$

$$E_1 = 4.44 f B_m A N_1$$

$$\begin{aligned} B_m &= \frac{\phi_m}{A} \\ \phi_m &= B_m A \end{aligned}$$

RMS Value of emf induced in s_y wdg

$$E_2 = 4.44 f \phi_m N_2$$

$$E_2 = 4.44 B_m A f N_2.$$

Transformation Ratio

for ideal transformer

$$V_1 = E_1, \quad V_2 = E_2.$$

$$V_1 I_1 = V_2 I_2, \quad E_1 I_1 = E_2 I_2.$$

$$\frac{V_2}{V_1} = \frac{I_1}{I_2}, \quad \frac{E_2}{E_1} = \frac{I_1}{I_2}.$$

$$\frac{E_2}{E_1} = \frac{N_2}{N_1} \Rightarrow \frac{E_2}{E_1} = \frac{N_2}{N_1} = \frac{I_1}{I_2} = k.$$

Where 'k' is called transformation ratio

THREE PHASE ALTERNATORS (SYNCHRONOUS GENERATOR)

Fundamental principle of electromagnetic Induction as like DC generator

When the flux linking a conductor changes, an emf is induced in the conductor.

In alternator, armature wdg. is mounted on a stationary element called STATOR.

Field wdg. is on a rotating element called ROTOR.

Advantages

- Better Insulation
- Ease of current collection
- Increased armature tooth strength
- More rigid construction
- ⇒ Reduced armature leakage reactance
- ⇒ lesser number of slip rings
- ⇒ lesser rotor weight and inertia
- ⇒ Improved ventilation & heat dissipation.

CONSTRUCTION OF ALTERNATOR:-

Stator → Stationary part with laminations
⇒ $A3\phi$ bldg is placed in these slots

ROTOR ⇒ Carries Field wdg which is supplied with DC through '2' slip rings by a separate DC source.

- 2 Types
- Salient pole (or) Projecting pole type
 - Non-salient pole (or) cylindrical type.

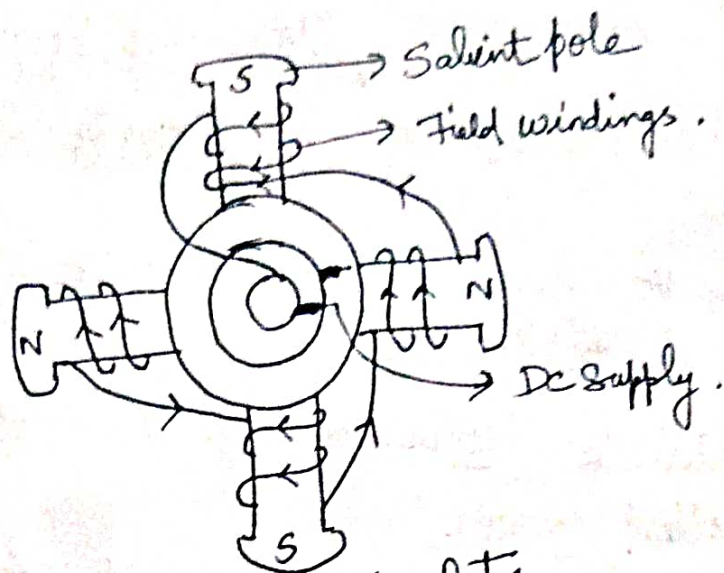

Salient pole rotor

- ⇒ Used for slow and moderate speed alternators
- ⇒ Can't be employed in high speed generators
- ⇒ Salient poles made of thick steel laminations
- ⇒ The pole faces are usually provided with slots for Damper windings → used in preventing hunting.

Special features :-

- ⇒ Large diameter & short axial length
- ⇒ Pole shoes cover about $\frac{2}{3}$ of pole pitch
- ⇒ Poles are laminated to reduce eddy current losses.
- ⇒ Employed with hydraulic turbines (or) diesel engines
Speed is from 120 to 400 rpm.

SMOOTH CYLINDRICAL (or) NON-SALIENT POLE TYPE :-

- ⇒ Used in high speed alternators
- ⇒ Diameter is reduced, axial length is increased

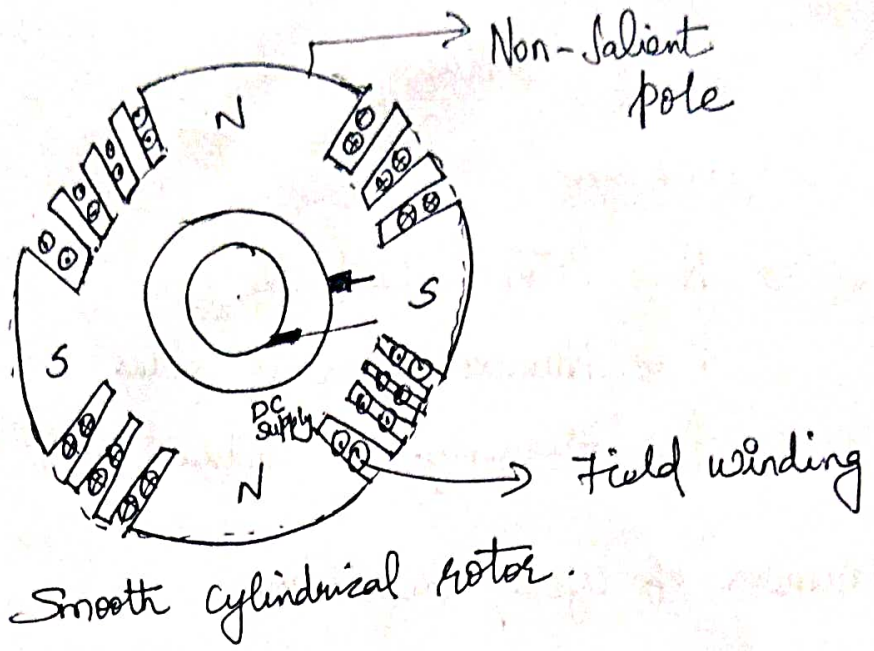

Smooth cylindrical rotor.

Features

- ⇒ Small diameter & very long axial length
- ⇒ less windage loss
- ⇒ Speed range is from 1,000 to 3,000 rpm
- ⇒ Better in dynamic balancing and quieter in operation
- ⇒ No need of Damper windings

Working of Alternator :-

As the rotor rotates, the armature conductors are cut by the magnetic flux. Hence an emf is induced in the armature conductors.

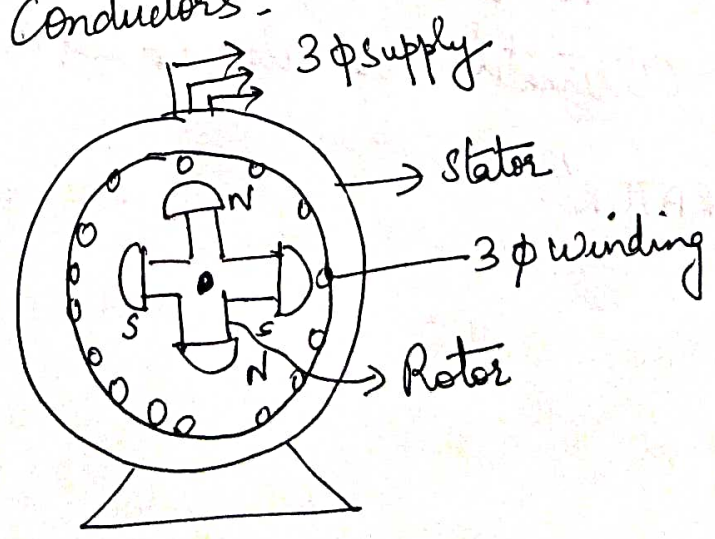

Frequency of Induced emf :-

Depends on

$\Rightarrow N \Rightarrow$ Rotor speed in rpm

$P \Rightarrow$ Number of Rotor poles

$f \Rightarrow$ Frequency of induced emf in Hz.

Number of cycles/ Revolution

$$= \text{No. of pairs of poles} = P/2$$

$$\text{No. of revolutions/sec} = N/60$$

$$\text{No. of cycles/sec} = \left(\frac{P}{2} \right) \left(\frac{N}{60} \right) = \frac{PN}{120}$$

$$\text{Frequency } f = \frac{PN}{120}$$

⊗ The alternators must run at Synchronous speed to give an o/p of desired frequency.
Hence alternators are also called as "SYNCHRONOUS GENERATOR".

PROBLEMS:-

(i) A 415V, 4 pole, 3φ alternator is driven at 1500rpm. Calculate the frequency of operation.

Given

- P = 4
- N = 1500rpm
- V = 415V

$$f = \frac{PN}{120} = \frac{(4)(1500)}{120} = 50\text{Hz}$$

$f = 50\text{Hz}$

Compare Salient pole Rotor & Smooth cylindrical rotor.

Salient Pole Rotor

- (1) Large diameter & short axial length
- (2) used for low speed alternators
- (3) Has projecting poles
- (4) Needs Damper windings
- (5) More Windage loss

Smooth cylindrical Rotor

- (1) small diameter & long axial length
- (2) Used for high-speed alternators
- (3) No projecting poles
- (4) Doesn't need Damper windings
- (5) less Windage loss.

THREE PHASE INDUCTION MOTORS.

(26)

Squirrel cage Induction motor

Wound Rotor (or) Slip Ring Induction motor.

CONSTRUCTION

It has '2' main parts

- ① stator
- ② Rotor

Stator:-

- ⇒ Made up of Stampings with alternate slot and tooth
- ⇒ Stampings are insulated from each other
- ⇒ Each stamping is 0.4 to 0.5 mm thick.
- ⇒ The 3 ϕ wdg is called "Stator winding" may be connected in star or Delta
- ⇒ The stator windings has fixed number of poles.

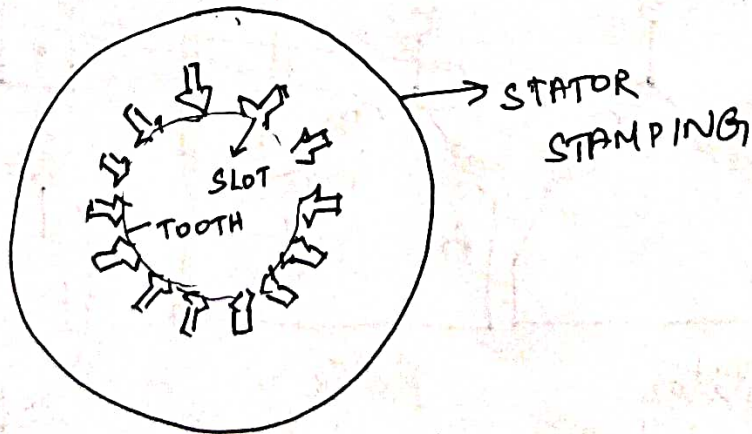

ROTOR $\left\{ \begin{array}{l} \text{Squirrel cage Rotor} \\ \text{Slip Ring (or) wound Rotor.} \end{array} \right.$

Squirrel Cage Rotor :

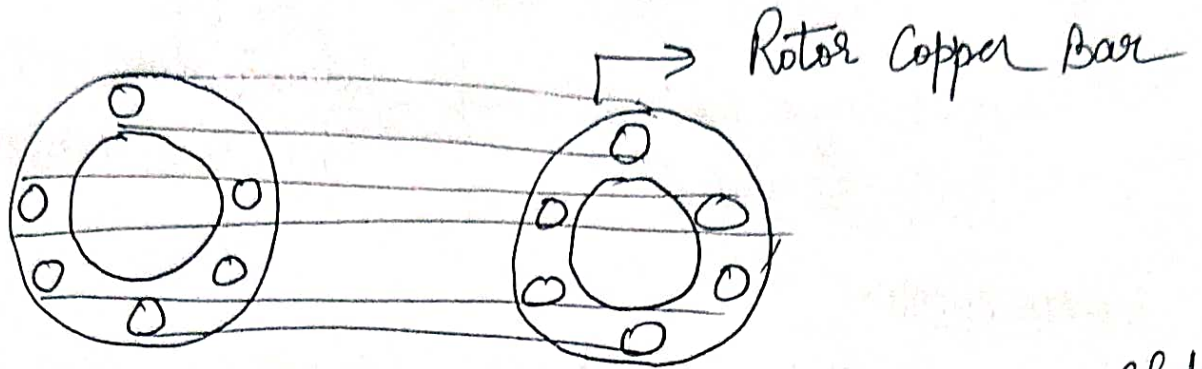

- ⇒ Made up of cylindrical laminated core with slots to carry rotor conductors
- ⇒ The rotor conductors are heavy bars of copper (or) aluminium short circuited at both ends by END RINGS
- ⇒ External Resistance cannot be connected in the rotor circuit

SLIP RING (OR) WOUND ROTOR :-

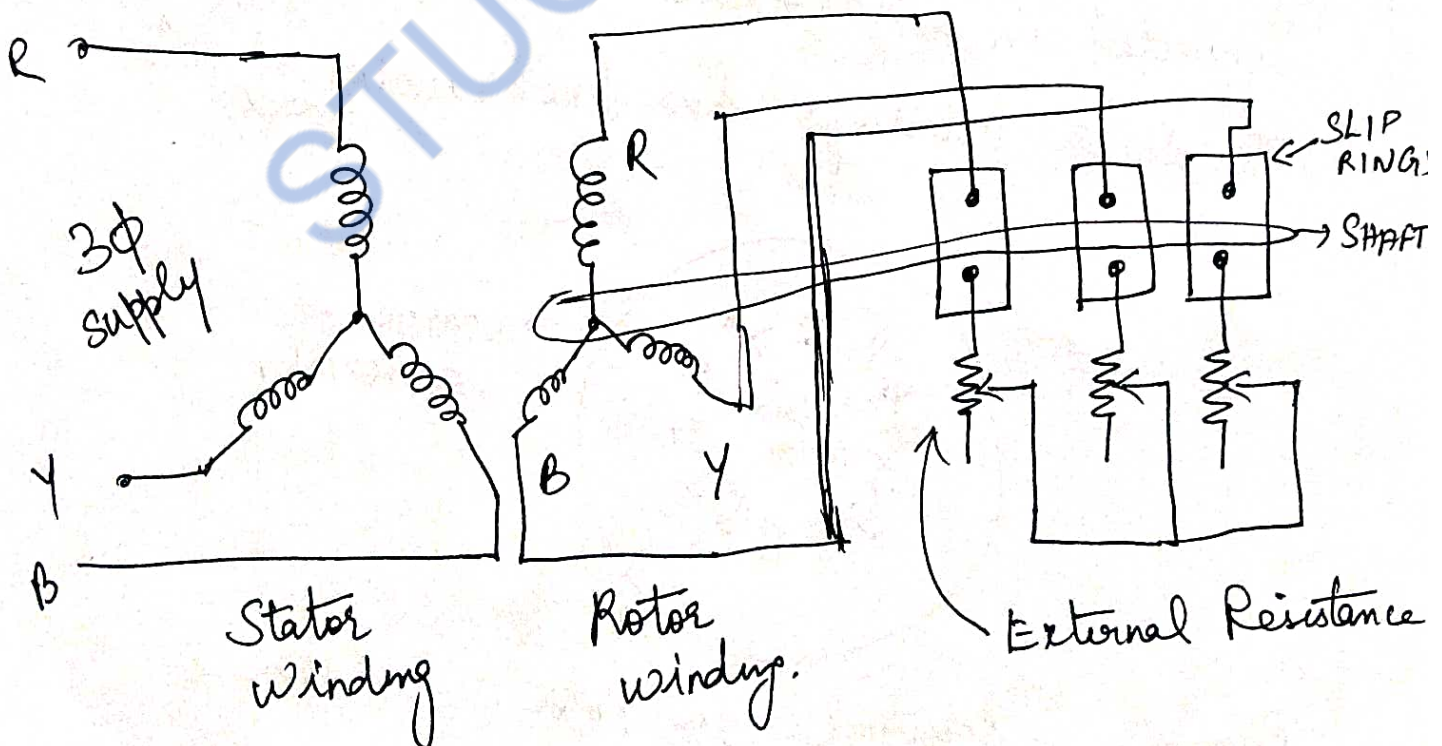

→ Rotor wdg similar to Stator winding which may be star connected (or) Delta Connected (27)

⇒ Variable external Resistance can be connected in the rotor circuit with the help of brushes & slip ring arrangements.

PRINCIPLE OF OPERATION:-

⇒ 3 ϕ supply is given to the stator winding

⇒ Due to this current flows through the stator wdg and it is called stator current.

$$\text{Where } N_s = \frac{120f}{P}$$

N_s ⇒ Synchronous speed

f ⇒ Supply frequency

P ⇒ Number of poles for which the stator is wound.

In an Induction motor, the rotor speed is always less than the synchronous speed.

$$\text{Slip Speed} = \left\{ \begin{array}{c} \text{Synchronous Speed} \\ (N_s) \end{array} \right\} - \left\{ \begin{array}{c} \text{Rotor Speed} \\ N \end{array} \right\}$$

$$\text{Slip Speed} = N_s - N$$

$$\text{Slip } S = \frac{N_s - N}{N_s}$$

$$\Rightarrow N = N_s (1 - S)$$

$$\% \text{ Slip} = \frac{N_s - N}{N_s} \times 100$$

Principle of operation of Three phase induction motor

- 3 ϕ supply is given to stator
- Rotating magnetic field is produced and it rotates at synchronous speed (N_s)
$$N_s = \frac{120f}{P}$$

N_s - Synchronous speed, f - frequency
 P - No. of stator poles
- This magnetic field is cut by rotor conductors
- Rotor emf is induced and current flows in closed rotor circuit.
- So rotor magnetic field is produced.
- Due to the interaction of stator and rotor magnetic field, torque is produced.
- Now rotor starts to rotate.
- The rotor speed (N) is always less than synchronous speed (N_s)

$$\text{Slip speed} = \text{Synchronous speed} - \text{Rotor speed}$$
$$\text{Slip speed} = N_s - N$$

$$\% \text{ Slip} = \frac{N_s - N}{N_s} \times 100$$

- At no load, slip is only about 1%.
- At full load, slip is about 3 to 5%.

Construction of Synchronous motor

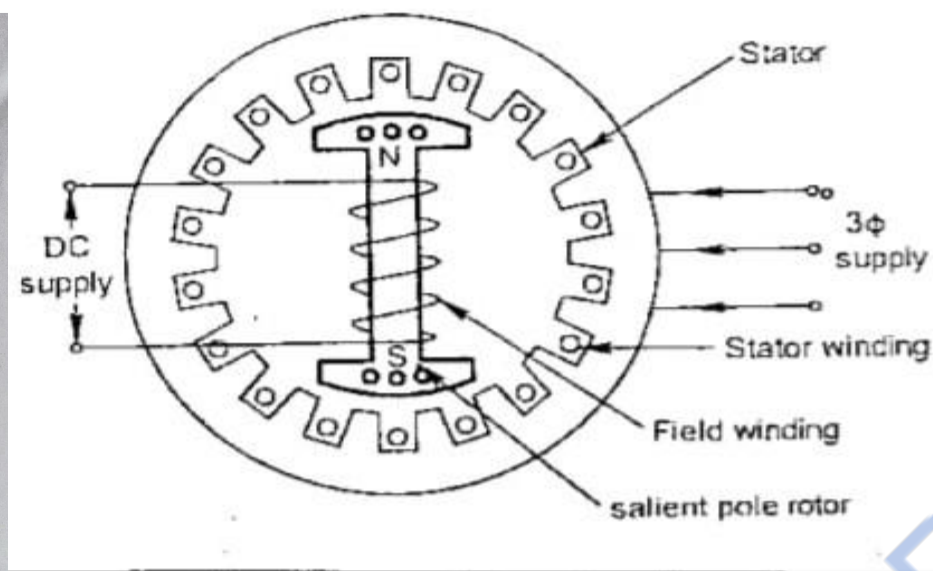

- Synchronous motor has 2 main parts
(i) Stator (ii) Rotor
- Stator stationary armature is supplied with 3 ϕ AC supply.
- DC supply is given to rotor. rotating field system.
- Stator consists of 3 ϕ laminated core with 3 ϕ armature winding.
- Rotor consists of salient poles with damper windings.
- Synchronous motor runs at constant speed called synchronous speed from no load to full load condition

$$N_s = \frac{120f}{p}$$

Principle of operation of Synchronous motor.

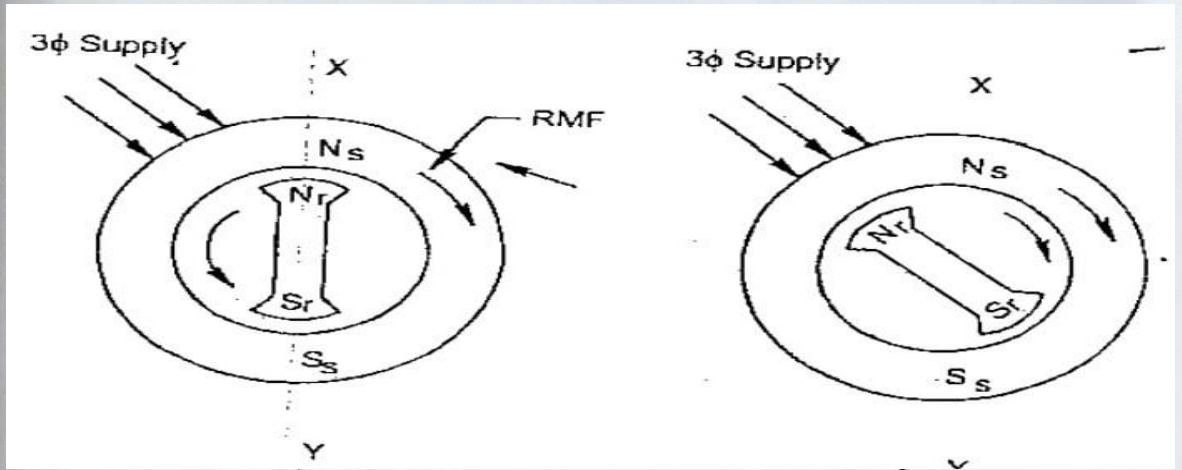

- 3 ϕ AC is given to stator winding.
- Rotating magnetic field is produced and it rotates in clockwise direction at synchronous speed.
- Stator poles are marked as N_s & S_s .
- DC Supply is given to rotor winding.
- Let rotor poles are marked as N_r & S_r . [fig 1]
- Like poles of N_s & N_r repel each other.
- Rotor move in anticlockwise direction (fig 2)
- After a half cycle, stator poles are interchanged (fig 3)

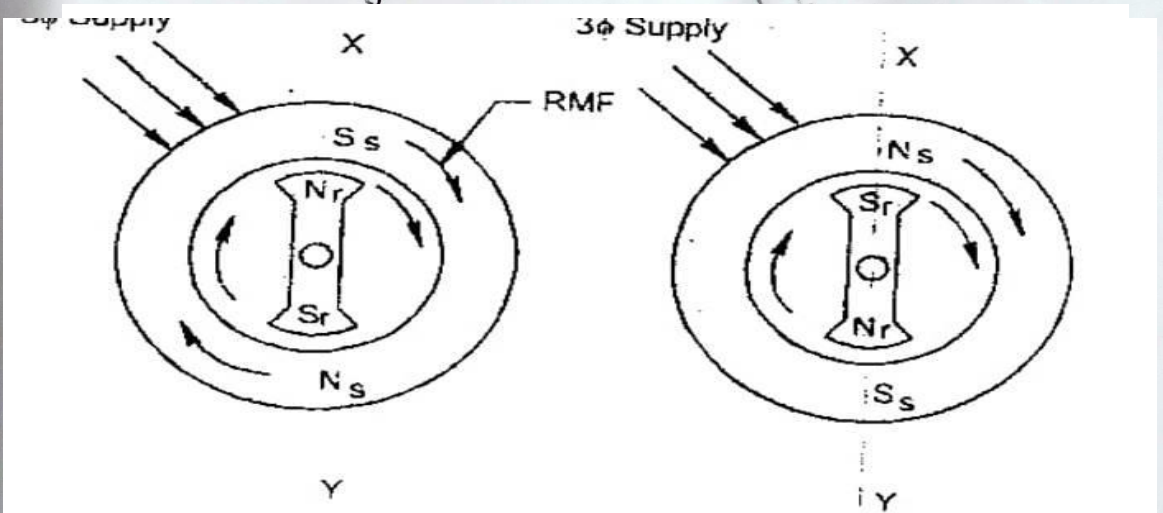

- Now S_s & N_r are attracted
Similarly N_s & S_r .
- Rotor tends to rotate in clockwise direction.
- Since repulsion and attraction takes place in every half cycle alternatively, the rotor is stationary.
- So synchronous motor is not self starting.
- If the rotor poles are rotated by some external means (such as using DC motor, pony motor) at a speed that they interchange their positions along with the stator poles, then the rotor will start to rotate.
- Because of the interlocking between stator and rotor poles, the motor runs only at synchronous speed.

Part-A.

1. What is DC generator?

DC generator is an electrical machine which convert mechanical energy into electrical energy.

2. What is DC Motor?

DC Motor is an electrical machine which convert electrical energy into mechanical energy.

3. What are the essential parts of a generator?

The essential parts of a generator are

1. Yoke
2. Magnetic poles, Field winding, Interpoles
3. Armature
4. Commutator
5. Brushes, shafts.

4. What is the purpose of yoke?

The purposes of yoke are

1. It act as a protective cover for the whole machine.
2. It provide mechanical support for the poles
3. It carries the magnetic flux produced by the poles

5. What is the function of commutator?

Commutator convert the alternating emf into direct emf.

6. Write the EMF equation of DC generator

$$E_g = \frac{P \phi N Z}{60 A} \text{ Volts.}$$

Where P - No. of poles, N - Speed, ϕ - flux, Z - No. of conductors

7. What is the function of brush in DC machine?

In DC generator, brushes are used to collect current from commutator and deliver it to the load.

In DC motor, brushes are used to supply current to armature.

8. What are the types of DC generator?

Types of DC generator are.

1. Separately excited DC generator
2. Self excited DC generator
 - DC shunt generator
 - DC series generator
 - DC compound generator
 - Short Shunt
 - Long Shunt

9. What is the principle of operation of DC motor?
Principle of operation of DC motor:

Whenever a current carrying conductor is placed in a magnetic field, it experiences a force tending to move it.

10. What is back emf? Give its significance.

• In DC motor, when the armature cuts the magnetic field, emf is induced in the armature. This emf is called back emf. The direction of the back emf opposes the supply voltage.
• The back emf regulates the armature current and it makes a motor self-regulating.

11. State the applications of DC generator

DC Shunt generator: used for battery charging, power supply purposes, lighting.

DC Series generator: used in DC traction, Series arc lighting, Series Boosters.

DC Compound generator: Used for power supply purposes, Arc welding, lighting.

12. List the types of DC motor

Types of DC motor

(i) DC Shunt motor

(ii) DC Series Motor

(iii) DC Compound motor

Short Shunt

Long Shunt

13. What is transformer?

Transformer is a static electrical machine which transfers electrical power from one circuit to another circuit without changing the frequency.

14. What are the types of transformer based on construction?

(i) Core type transformer (ii) Shell type transformer

15. Write the principle of operation of transformer

Transformer works on the principle of electromagnetic induction. EMF is induced in primary winding by self induction principle. EMF is induced in secondary winding by mutual induction principle.

16 write the application of DC Motor

DC Shunt Motor :- Used in lathe, light machine tools
Centrifugal pumps.

DC Series Motor :- Used in cranes, conveyors and
electric locomotives

DC Compound Motor :- Used in driving punching machines
heavy machine tools

17. Write the applications of transformer

(i) Transformers are used to step up or step down the voltage

(ii) It is used for transmission and distribution of electrical power

(iii) It is used in radio, TV and telephone circuits

18 Write the EMF equation of transformer.

$$E_1 = 4.44 f \Phi_m N_1$$

$$E_2 = 4.44 f \Phi_m N_2$$

Where E_1, E_2 - EMF induced in primary & secondary winding.

f - frequency

Φ_m - Max. Flux.

N_1, N_2 - No. of turns in primary & secondary.

19. Define voltage transformation ratio

$$\frac{E_2}{E_1} = \frac{N_2}{N_1} = k$$

It is the ratio of emf induced in secondary winding to emf induced in primary winding.

20. Define slip in induction motor

Slip is the ^{ratio of} difference between synchronous speed (N_s) and rotor speed (N_r) to synchronous speed.

$$\% S = \frac{N_s - N_r}{N_s} \times 100$$

21. Why transformer induction motor is called rotating transformer?

The rotor of induction motor receives the power due to mutual induction like the secondary winding of transformer receive power from primary. So induction motor is called rotating transformer.

22. What are the 2 types induction motor based on rotor construction? Which motor has more efficiency?
(i) Squirrel cage induction motor
(ii) Slip ring induction motor

23. What are the 2 types of alternators based on construction of rotor?
(i) Salient pole and (ii) Non Salient pole alternators

24. Calculate the emf generated by a 4 pole, wave wound armature having 45 slots with 18 conductors per slot when driven at 1200 rpm, the flux per pole is 0.016 wb.

Formula Used. $E_g = \frac{P \phi N Z}{60A}$

Given data

$$P = 4$$

$$N = 1200 \text{ rpm}$$

$$\phi = 0.016 \text{ wb}$$

Wave wound [A=2]

Solution: $Z = \text{No. of slot} \times \text{conductors per slot}$

$$Z = 45 \times 18 = 810 \text{ conductors}$$

$$E_g = \frac{P \phi N Z}{60A} = \frac{4 \times 0.016 \times 1200 \times 810}{60 \times 2}$$

$$E_g = 518.4 \text{ V}$$

25. The primary and secondary voltages of a 25 kVA power transformer are 2200V and 220V. The transformer has 56 turns in the secondary. Calculate the number of turns in primary.

Given data:

$$E_1 = 2200, E_2 = 220 \text{ V}, N_2 = 56.$$

$$\text{Formula Used :- } \frac{E_2}{E_1} = \frac{N_2}{N_1}$$

$$\frac{220}{2200} = \frac{56}{N_1}$$

$$\frac{1}{10} = \frac{56}{N_1}$$

$$\Rightarrow N_1 = 56 \times 10 = 560 \text{ turns}$$

26. The no load ratio required in a 1 ϕ 50 Hz transformer is 6600/300V. If the maximum value of flux is 0.09 weber. Find the number of turns in each winding.

Given data $E_1 = 6600 \text{ V}, E_2 = 300 \text{ V}, f = 50 \text{ Hz}$
 $\phi = 0.09 \text{ wb.}$

$$E_1 = 4.44 f \phi_m N_1$$

$$6600 = 4.44 \times 50 \times 0.09 \times N_1$$

$$N_1 = 330 \text{ turns}$$

$$E_2 = 4.44 f \phi_m N_2$$

$$300 = 4.44 \times 50 \times 0.09 \times N_2$$

$$N_2 = 15 \text{ turns}$$

27. What is rotating magnetic field? At what speed it rotates?

The magnetic field which has constant amplitude and rotates at a certain speed in axially in a plane.

It rotates at a speed called synchronous speed.

$$N_s = \frac{120f}{P}$$

N_s - Synchronous Speed, f - frequency, P - No. of poles,

28. State the different losses which occur in a transformer
(i) Hysteresis loss (ii) Eddy current loss (iii) Copper loss

29. Compare salient pole and cylindrical type alternators

Salient pole	Cylindrical type.
① Rotor poles are projected	① Rotor poles are not projected.
② Rotor diameter is large	② Rotor diameter is small
③ Smaller Axial length	③ Larger Axial length.
④ Used in low and medium speed alternators	④ Used in high speed alternators
⑤ Non uniform air gap	⑤ Uniform air gap.
⑥ It has more no. of poles	⑥ It has 2 or 4 poles.

30. Compare 3 ϕ induction motor and Synchronous motors

3 ϕ Induction motor	Synchronous motor
<ul style="list-style-type: none">(i) Self Starting(ii) Rotor speed $< N_s$(iii) Operate in lagging pf(iv) Separate DC Source is not needed for rotor excitation(v) Construction is simple(vi) Motor is cheap & maintenance free	<ul style="list-style-type: none">(i) Not self starting(ii) Runs at only N_s.(iii) Operate in lagging, leading, Uf.(iv) Separate DC Source is not needed.(v) Construction is complicated.(vi) Motor is costly and frequent maintenance is required.

31. Write the applications of synchronous motor

- (i) Used as synchronous condensers for power factor improvement.
- (ii) Used to regulate transmission line voltage
- (iii) Used in textile mill, paper mill, centrifugal pumps.

32. Write the applications of 3 ϕ induction motor
Used in lathes, drilling machines, fans, grinders, blowers etc.

32. Why Synchronous motor is not self starting?

The stator poles change their polarities rapidly, they tend to pull the rotor first in clockwise direction and after a half cycle in anticlockwise direction. Due to high inertia of motor, the motor fails to start. So Synchronous motor is not self starting.

33. Define Synchronous speed

The speed at which the rotating flux revolves is called synchronous speed.

$$N_s = \frac{120f}{P} \text{ where } f - \text{supply frequency} \\ P - \text{No. of poles.}$$

34. Write the voltage equation of a DC motor

$$V = E_b + I_a R_a$$

V - Applied Voltage, E_b - back emf

I_a - Armature current R_a - Armature Resistance

35. Write the torque equation of a DC Motor

$$T_a = 0.159 \phi I_a \frac{PZ}{A} \text{ NM}$$

Where T_a - Torque in NM, ϕ - flux in wb, P - No. of poles

I_a - Armature current, Z - Total no. of conductors

A - Number of parallel paths.

36. What is meant by step up and step down transformers?

If $N_2 > N_1$, the voltage is step up from low voltage to high voltage, then it is called step up transformer.

If $N_1 > N_2$, the voltage is step down from high voltage to low voltage, then it is called step down transformer.

37. A 6 pole 3 ϕ induction motor is connected to 50 Hz supply. If it is running at 970 rpm. Find the % slip.

Given Data: $P = 6$, $f = 50 \text{ Hz}$, $N_r = 970 \text{ rpm}$.

$$\% \text{ Slip} = \frac{N_s - N_r}{N_s} \times 100, \quad N_s = \frac{120f}{P} = \frac{120 \times 50}{6} = 1000 \text{ rpm}$$

$$\% \text{ Slip} = \frac{1000 - 970}{1000} \times 100 = 3\%$$

38. A 3 ϕ 4 pole, 50 Hz induction motor is running at 1440 rpm. Determine the slip speed and % slip.

Given Data: $P = 4$, $f = 50 \text{ Hz}$, $N_r = 1440 \text{ rpm}$.

$$N_s = \frac{120f}{P} = \frac{120 \times 50}{4} = 1500 \text{ rpm}$$

$$\text{Slip speed} = N_s - N_r = 1500 - 1440 = 60 \text{ rpm}$$

$$\% \text{ Slip} = \frac{N_s - N_r}{N_s} \times 100 = \frac{1500 - 1440}{1500} \times 100 = 4\%$$

39. Compare squirrel cage and slip ring induction motor.

40. Compare 3 ϕ induction motor and transformer.

UNIT-2 - ELECTRICAL MACHINES

DC GENERATOR:

An electrical generator is a rotating machine which converts mechanical energy into electrical energy.

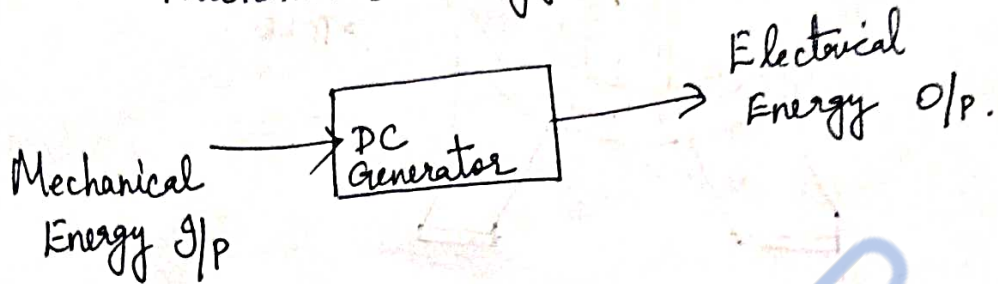

Faraday's Law of Electromagnetic Induction:-

Whenever a conductor is moved in a magnetic field, dynamically induced emf is produced in the conductor.

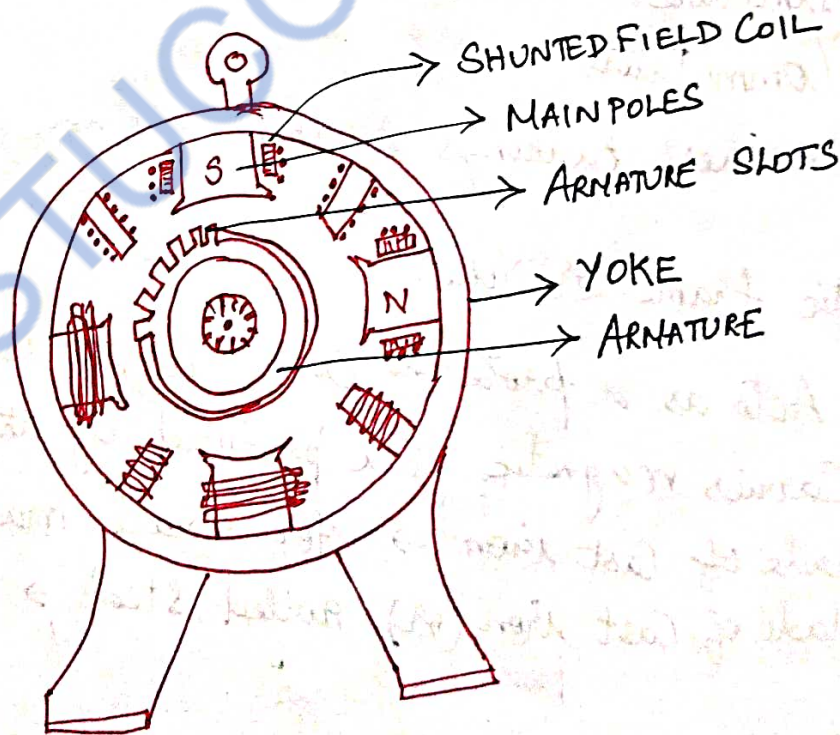

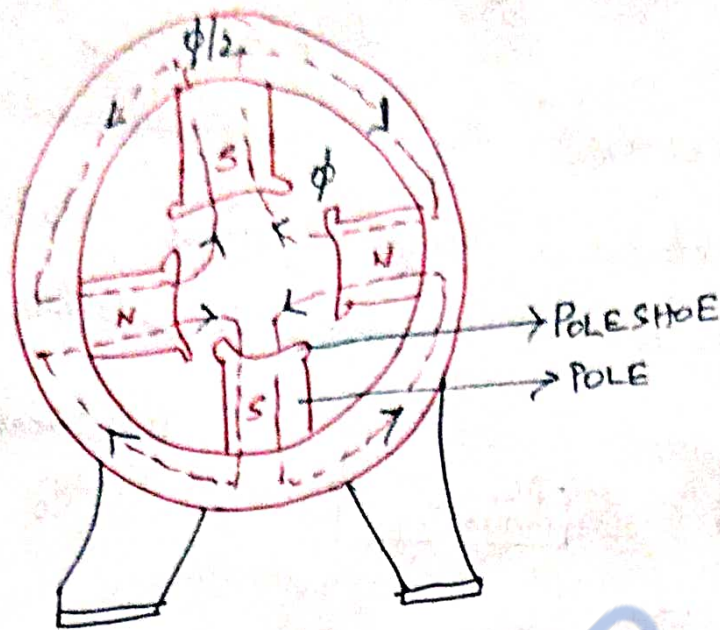

Major parts of a DC Generator

- ① Magnetic frame (or) Yoke
- ② Poles, Interpoles, windings, Pole shoes
- ③ Armature
- ④ Commutator
- ⑤ Brushes, bearings & shaft.

Magnetic frame (or) Yoke:-

- Acts as a protecting cover for the whole machine.
- Carries magnetic flux produced by the poles.
- Made of Cast iron → for small machines
- Made of Cast iron (or) rolled steel → for large machines

Poles:-

- Consist of pole core, pole shoe & Pole coils
forms the field magnet

- (2)
- The pole coils are made up of copper wire or strip.
 - To minimize eddy current losses, the poles is laminated. Sheet steel laminations are used for this.

Interpoles:

- To improve commutation.

Armature:

- Consist of armature core and armature windings

↓
Houses armature conductors or coils

- The armature along with the conductors rotates under the poles and hence, the flux produced by the field magnets is cut by the armature conductors.

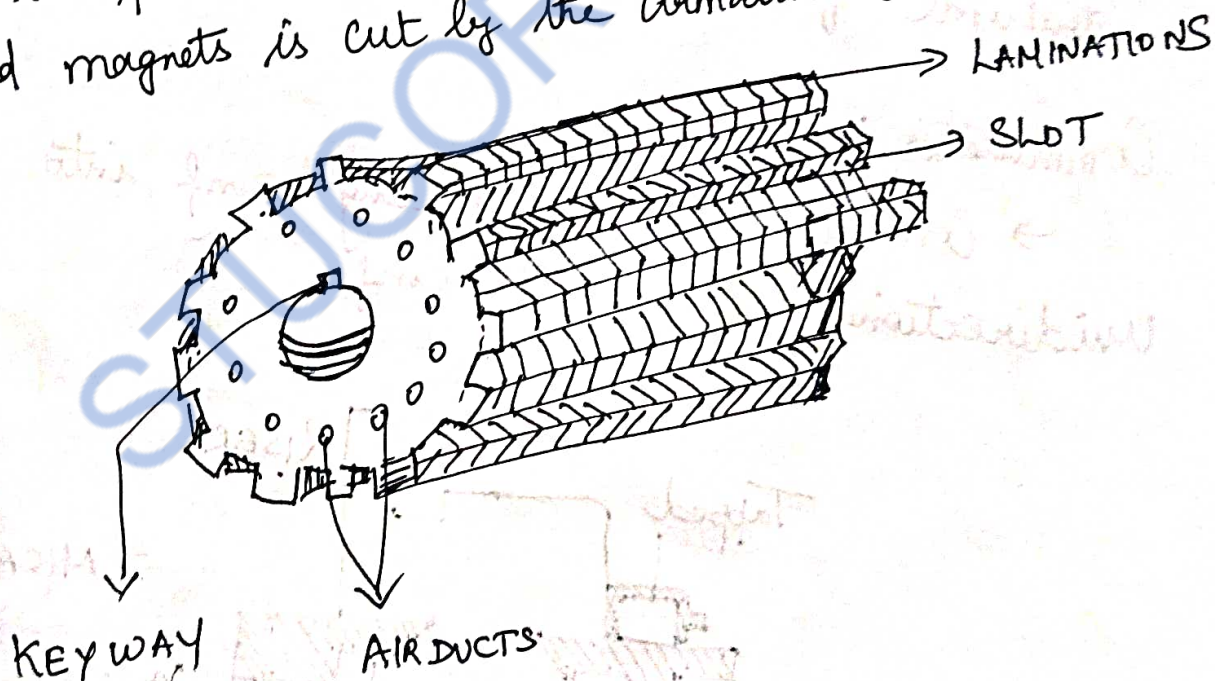

- To reduce losses, low hysteresis steel containing a few percentage of silicon is used in the armature.

→ To reduce (or) minimize the eddy current losses, the armature core is laminated.

→ The laminations are about 0.4 mm to 0.5 mm thick.

→ The eddy current losses and hysteresis losses produce considerable heat in the armature and spacers.

→ Ventilating ducts may be necessary to remove this heat.

→ The slots are rectangular in shape - for larger machines.

→ The slots are circular in shape - for small machines.

→ The slots are closed by files (or) wooden wedges to prevent the conductors from flying out due to centrifugal force when the armature rotates.

Commutator :-

→ Converts the alternating emf into unidirectional or direct emf.

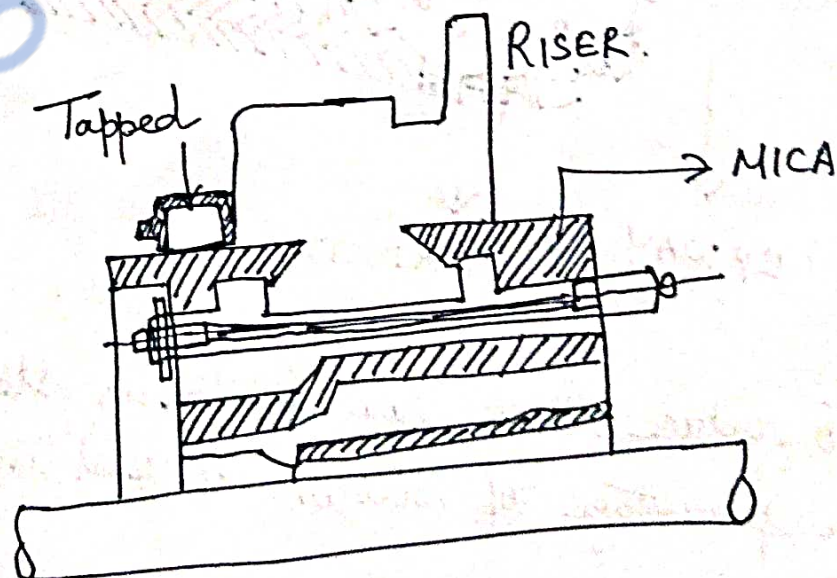

Construction of Commutator

BRUSHES AND BEARINGS:-

- Brushes are made up of carbon or graphite
- Collect the current from the commutator and to the external load resistance.
- Ball bearings are usually employed as they are reliable for light machines.

PRINCIPLE OF OPERATION.

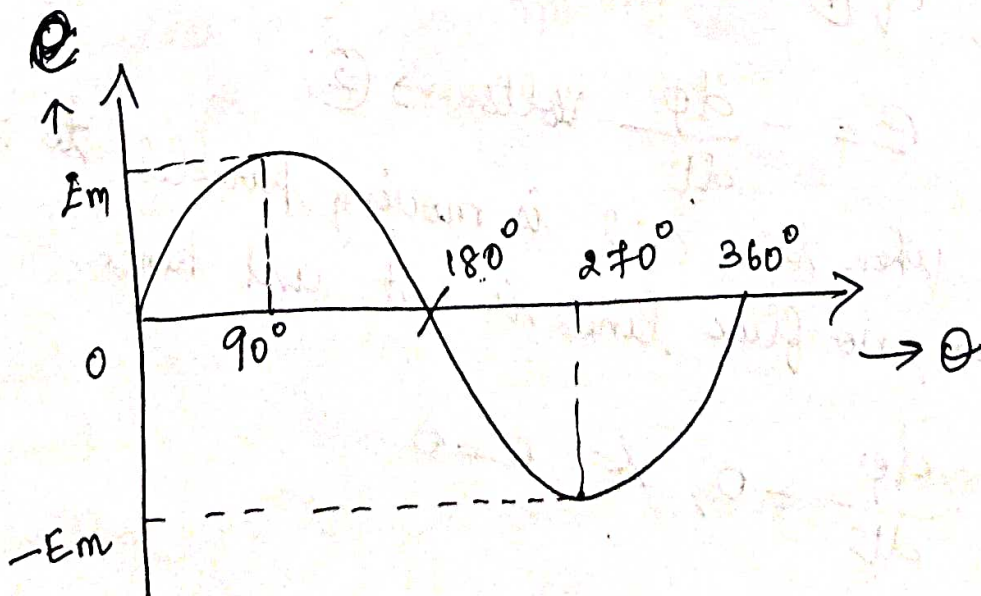
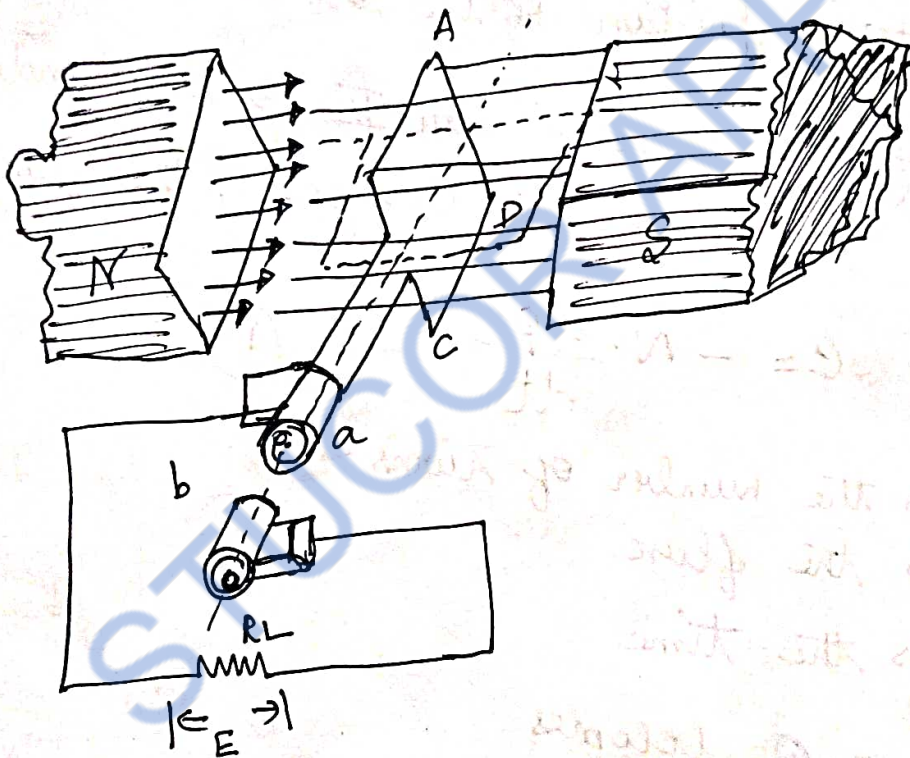

Let 'l' \rightarrow Length of the coil in meters

'b' \rightarrow Breadth of the coil in meters

When the coil sides AB and CD are moving parallel to the magnetic field, the flux lines are not being cut and no emf induced in the coil.

At this position, it is assumed that the angle of rotation ' θ ' as zero.

\rightarrow This vertical position of the coil is the starting position.

\rightarrow According to Faraday's law II \rightarrow EMF induced is proportional to the rate of change of the flux linkages.

$$e = -N \cdot \frac{d\phi}{dt} \rightarrow \textcircled{1}$$

Where 'N' is the number of turns

' ϕ ' is the flux

't' is the time

As $N=1$, eq $\textcircled{1}$ becomes

$$e = -\frac{d\phi}{dt} \text{ Volts} \rightarrow \textcircled{2}$$

Initially when the coil is moving parallel to the flux lines, no flux line is cut and hence

$$\frac{d\phi}{dt} = 0, \& e = 0$$

After time 't' secs, the coil would have rotated through an angle " ωt " radians in the anti-clockwise direction. (4)

The flux then linking with the coil is $B l b \cos \theta$.

$$e = -\frac{d}{dt} (B l b \cos \omega t) = +B l b \sin \omega t (\omega)$$

Where $E_m = B l b \omega$

($B \rightarrow$ Flux Density
 $E_m \Rightarrow$ Maximum value of induced emf)

$$\therefore e = E_m \sin \omega t$$

When $\theta = 90^\circ$

\rightarrow Coil sides moving at right angles to the flux lines.

\rightarrow The flux lines are cut at the maximum rate and the emf induced is maximum.

When $\theta = 180^\circ$

\rightarrow Coil sides are again moving parallel to the flux lines but with the position reversed

When $\theta = 360^\circ$ or 270°

Coil sides moving at right angles but position reversed.

When $\theta = 360^\circ \Rightarrow$ Coil sides once again parallel and induced emf is zero.

The induced emf in the coil can be increased by

→ Increasing the flux density (B).

→ Increasing the angular velocity (ω)

→ The current flowing in the external resistance to a DC generator is made unidirectional by replacing the slip rings by a split rings.

In a generator, the split rings are called Commutator.

EMF INDUCED IN A DC GENERATOR:-

Let ' ϕ ' be the flux/pole in webers

Let ' p ' be the number of poles.

Let ' z ' be the total number of conductors in the armature.

→ All the ' z ' conductors are not connected in series.

→ They are divided into groups.

→ Let ' A ' be the number of parallel paths into which the conductors are grouped.

→ So each parallel path will have z/A conductors in series.

→ ' N ' be the speed of rotation in revolutions per minute (rpm).

$$e \propto \frac{d\phi}{dt}$$

$$e = \frac{P\phi}{60/N} \text{ volts.}$$

As this conductor makes one complete revolution, it cuts $P\phi$ webers. As the speed is 'N' rpm, the time taken for one revolution is $60/N$ seconds.

$$[\therefore d\phi = P\phi \ \& \ dt = 60/N]$$

Since there are Z/A conductors in series, in each parallel path, the emf induced is

$$E_g = \frac{NP\phi}{60} \left(\frac{Z}{A} \right) \Rightarrow \frac{\phi Z N}{60} \left(\frac{P}{A} \right) \text{ Volts}$$

Connection of armature conductors

lap wound

Number of parallel path

= Number of poles

$$\boxed{A = P}$$

wave wound

A is always '2'

$$\boxed{A = 2}$$

PROBLEMS :-

- Calculate the emf generated by a 6 pole DC generator having 480 conductors and driven at a speed of 1200 rpm. The flux/pole is 0.012 wb. Assume the generator to be
 (a) lap wound (b) wave wound.

Solution

Number of conductors = 480

Speed N (r) = 1200 rpm

Flux/pole $\phi = 0.012$ wb

Number of poles $P = 6$ poles.

\therefore The emf generated $E_g = \frac{\phi Z N}{60} \left(\frac{P}{A} \right)$.

(a) For lap wound machine

$$A = P = 6$$

$$E_g = \frac{0.012 \times 480 \times 1200 \times 6}{60 \times 6} = 115.2 \text{ Volts}$$

(b) For wave wound machine

$$A = 2$$

$$E_g = \frac{0.012 \times 480 \times 1200 \times 6}{60 \times 2} = 345.6 \text{ Volts.}$$

$$E_g = 345.6 \text{ V}$$

Types of DC Generator:

Separately Excited DC generators self Excited DC generators

Separately Excited DC generators:

If the field winding is excited by a separate DC supply, then the generator is called separately Excited DC generator.

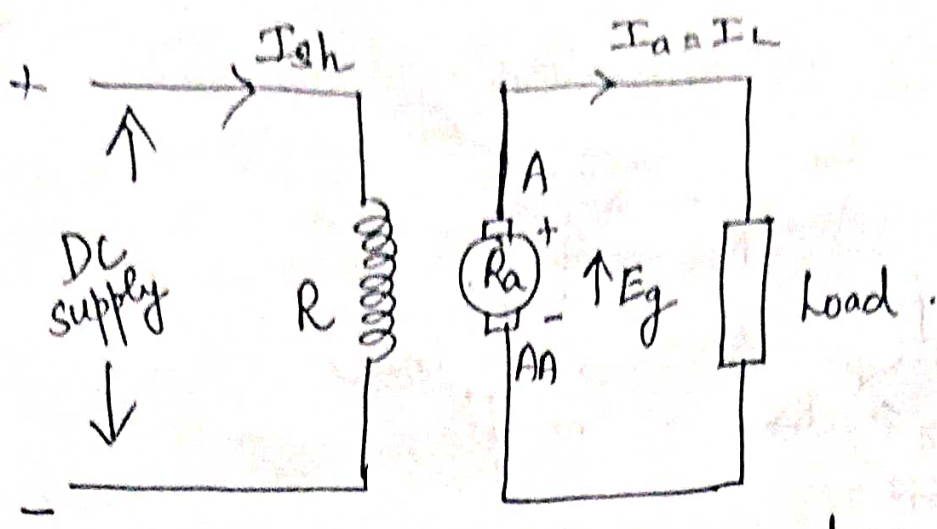

Separately excited DC generators.

→ The field winding has large number of turns of thin wire

Armature current $I_a =$ Load current I_L

$R_a \Rightarrow$ Resistance of the armature winding

Terminal voltage $V = E_g - I_a R_a - V_{brush}$

$V_{brush} =$ Voltage drop at the contacts of the brush
(Neglected because of low value)

∴ Generated EMF $E_g = V + I_a R_a + V_{brush}$

If V_{brush} is neglected

$$E_g = V + I_a R_a$$

Electric power developed $P_a = E_g I_a$

Power delivered to the load $P_o = V I_a$

Self-Excited DC Generators :-

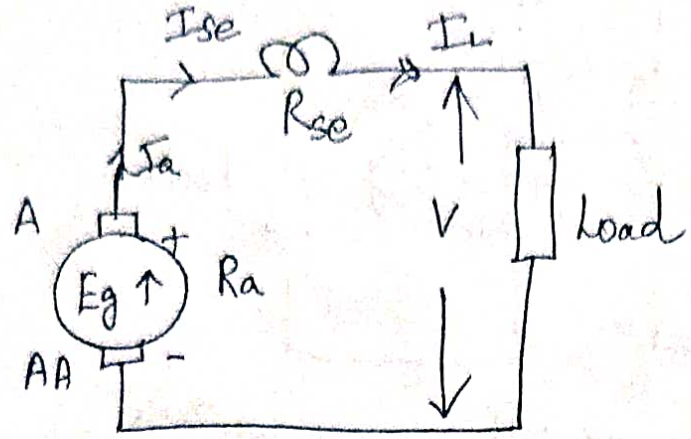

⇒ If the field wdg is supplied from the armature of the generator itself, then it is called a Self-excited DC generator.

⇒ Residual flux is present in the poles

Depending upon how the field wdg is connected to the armature

- Series Generator
- Shunt Generator

(i) Series Generator :- (DC Series Generator)

⇒ Field wdg is connected in series with the armature

⇒ Armature current flows through the field winding as well as the load.

⇒ The field wdg has less number of turns of thick wire
 ⇒ It has low resistance denoted by R_{se}

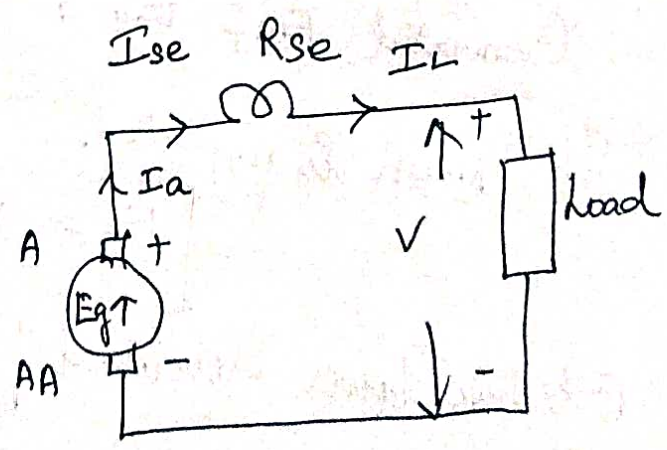

$$I_a = I_{se} = I_L$$

Generated emf

$$E_g = V + I_a R_a + I_a R_{se} + V_{brush}$$

Where $V \Rightarrow$ Terminal voltage in volts
 $I_a R_a =$ Voltage drop in the armature resistance
 $I_a R_{se} =$ Voltage drop in the series field wdg resistance

$V_{brush} =$ Brush drop.

$$\text{Terminal voltage } V = E_g - I_a R_a - I_a R_{se} - V_{brush}$$

Power developed in the armature $P_a = E_g I_a$.

Power delivered to load $P_o = V I_a$ (or) $V I_L$.

SHUNT GENERATOR:-

- \Rightarrow Field wdg connected across the armature.
- \Rightarrow load connected parallel across the armature.
- \Rightarrow Shunt field wdg has more number of turns of this wire
- \Rightarrow High Resistance.

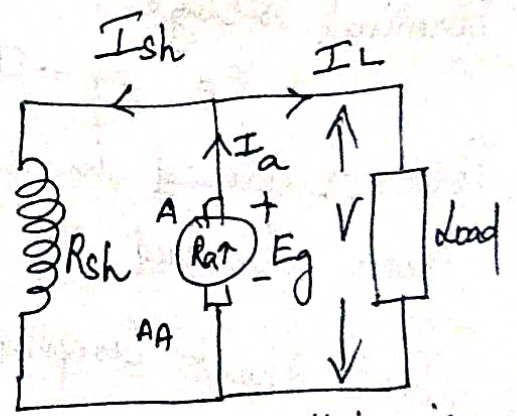

$$\text{Terminal voltage } V = E_g - I_a R_a$$

$$\text{Shunt Field current } I_{sh} = \frac{V}{R_{sh}}$$

$$\text{Armature current } I_a = I_{sh} + I_L$$

Power developed by armature $P_a = E_g I_a$

Power delivered by the load $P_o = V I_L$.

COMPOUND GENERATOR :-

⇒ Consist of both shunt field and series field winding
 Depending upon the shunt field & series field connections,
 Compound generator can be classified as

- ① Long Shunt Compound Generator
- ② Short Shunt Compound Generator

Long Shunt Compound Generator

Series Field current

$$I_{se} = I_a = I_L + I_{sh}$$

$$\text{Shunt Field current } I_{sh} = \frac{V}{R_{sh}}$$

Generated EMF

$$E_g = V + I_a (R_a + R_{se}) + V_{brush}$$

Terminal voltage

$$V = E_g - I_a (R_a + R_{se}) - V_{brush}$$

$$\text{Power developed in armature } P_a = E_g I_a$$

$$\text{Power delivered to load } P_o = V I_L$$

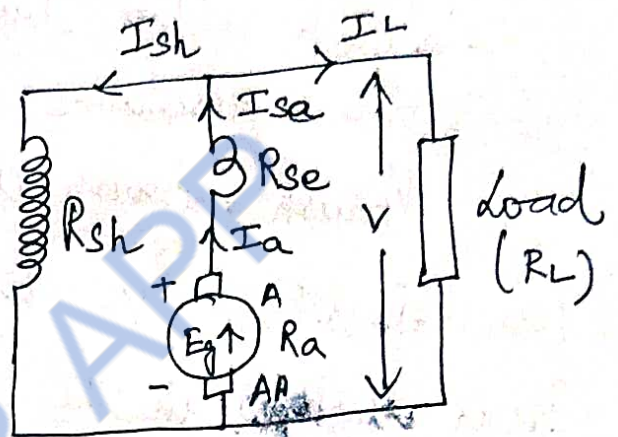

Short Shunt Compound Generator :-

Shunt field wdg is connected in parallel with the armature and this combination is connected in series with series field winding

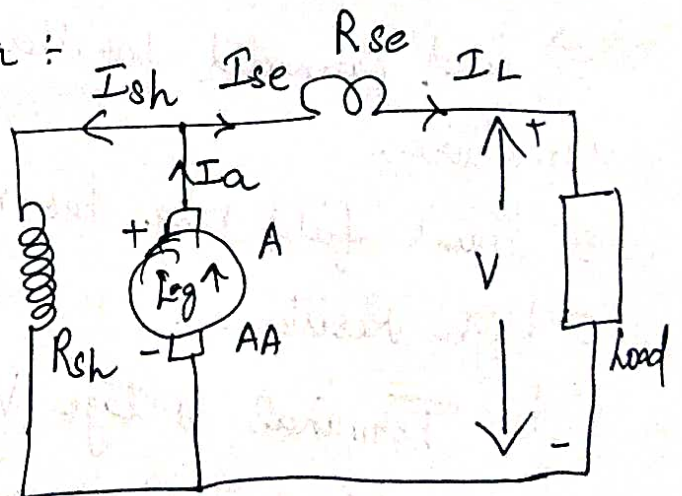

Series field current $I_{se} = I_L$ (load current)

$$I_a = I_{sh} + I_{se}$$

Generated emf $E_g = V + I_a R_a + I_{se} R_{se} + V_{brush}$

Voltage across shunt field winding = $I_{sh} R_{sh}$

$$I_{sh} R_{sh} = E_g - I_a R_a - V_{brush}$$

$$= V + I_a R_a + I_{se} R_{se} + V_{brush} - I_a R_a - V_{brush}$$

$$= V + I_{se} R_{se}$$

$$\text{Shunt Field current } I_{sh} = \frac{V + I_{se} R_{se}}{R_{sh}}$$

Terminal voltage $V = E - I_a R_a - I_{se} R_{se} - V_{brush}$

Power developed in armature $P_a = E_g I_a$

Power delivered to load $P_o = V I_L$

Problems:-

① A DC series generator delivers a load of 20 kW at 400 V. Its armature and series field ~~resistances~~ resistances are 0.3Ω and 0.2Ω respectively. Calculate the generated emf and the armature current. Allow 1.1 V/brush for contact drop.

Solution O/p power $P_{out} = 20 \text{ kW}$

Load voltage $V_L = 400 \text{ V}$

Armature resistance $R_a = 0.3 \Omega$

Series Field resistance $R_{se} = 0.2 \Omega$

Brush drop / brush = 1.1 V

$$E_g = ? \quad E_g = V_L + (I_a)(R_a + R_{se}) + V_{brush}$$

$$\text{Load Current } I_L = \frac{P_{out}}{V_L} = \frac{20 \times 10^3}{400} = 50 \text{ A}$$

∴ Generated emf

$$E_g = V_L + I_a(R_a + R_{se}) + V_{brush}$$

$$= 400 + 50(0.3 + 0.2) + 1.1 \times 2$$

$$E_g = 427.2 \text{ V}$$

② A 4-pole shunt generator, with a lap wound armature has field resistance of 50Ω and armature circuit resistance of 0.1Ω . The generator is supplying sixty, 100 V , 50 W lamps. Find the total armature current in each armature conductor and generated emf. The brush contact drop is 1 V/brush .

Sol $P = 4$ (Number of poles)

Shunt field resistance $R_{sh} = 50 \Omega$

Armature resistance $R_a = 0.1 \Omega$

Total power supplied $P_o = 60 \times 40 = 2400 \text{ W}$

Brush drop $V_{brush} = 2 \times 1 = 2 \text{ V}$

Terminal voltage $V = 100 \text{ V}$

To find Armature current I_a
Generated emf E_g

Sol

Total power supplied

$$P_o = 60 \times 40$$

$$P_o = 2400 \text{ W}$$

$$\text{Load current } I_L = \frac{P_o}{V} = \frac{2400}{100} = 24 \text{ A}$$

$$\text{Shunt field current } I_{sh} = \frac{V}{R_{sh}} = \frac{100}{50} = 2 \text{ A}$$

$$\text{Armature current } I_a = I_L + I_{sh} = 24 + 2 = 26 \text{ A}$$

$$I_a = 26 \text{ A}$$

Current / armature parallel path

$$= \frac{I_a}{A} = \frac{I_a}{P} = \frac{26}{4} = 6.5 \text{ A} \quad \begin{matrix} (A = P) \\ (\text{lap connection}) \end{matrix}$$

$$\begin{aligned} \text{Generated emf } E_g &= V + I_a R_a + V_{\text{brush}} \\ &= 100 + (26 \times 0.1) + (1 \times 2) \end{aligned}$$

$$E_g = 104.6 \text{ V}$$

APPLICATIONS OF DC GENERATORS:

- Used for battery charging for supplying the fields of synchronous machines & separately excited DC machines
- Voltage of a series generator \uparrow with load \uparrow , hence used as boosters for adding a voltage to the transmission line and to compensate for the line drop.
- Maintain better voltage regulation and hence find use where constancy of voltage is required.

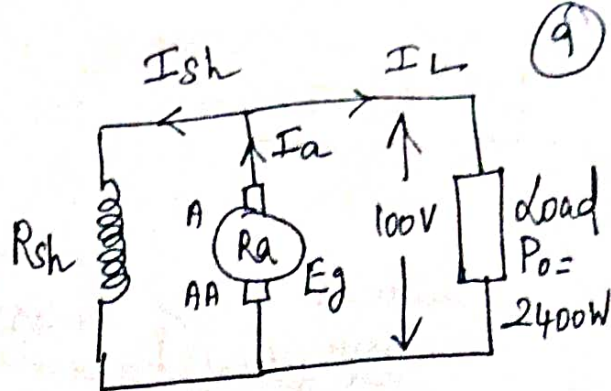

DC MOTORS :-

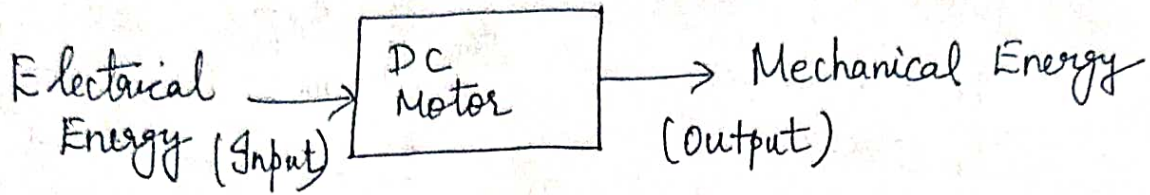

Working Principle of DC motor :-

⇒ Whenever a current carrying conductor is placed in a magnetic field, it experiences a force tending to move it.

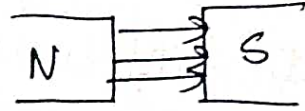

The magnitude of the force experienced by the conductor in a motor is given by

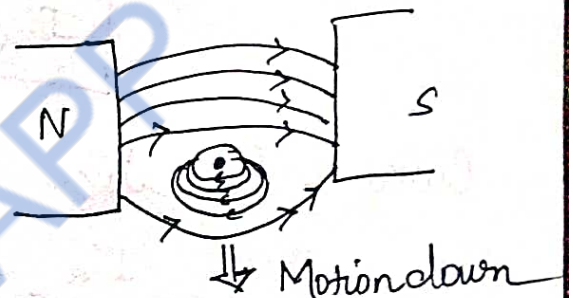

$$F = BIL \text{ Newton}$$

Where $B \Rightarrow$ Magnetic field intensity in Wb/m^2

$I \Rightarrow$ Current in amperes

$l \Rightarrow$ length of the conductor in meters

→ The direction of motion is given by Fleming's left Hand rule.

If the thumb, fore finger and middle finger of the left hand are held such the three fingers are mutually perpendicular in direction, fore finger indicates direction of the field, middle finger indicates the direction of current and the thumb points, the direction of motion of conductor.

Back EMF

Even when the machine is working as a motor, voltages are induced in the conductors. This emf is called the BACK EMF (OR) COUNTER EMF, since the cause for this is the rotation, which in turn is due to the supply voltage.

According to LENZ'S LAW, the direction of the back emf opposes the supply voltage.

$$E_b (\text{Back EMF}) = \frac{\Phi Z N}{60} \cdot \frac{P}{A} \text{ Volts}$$

Voltage Equation of this DC motor is

$$V = E_b + I_a R_a \text{ Volts}$$

$$\therefore I_a R_a = V - E_b$$

$$I_a = \frac{V - E_b}{R_a} \text{ Ampere}$$

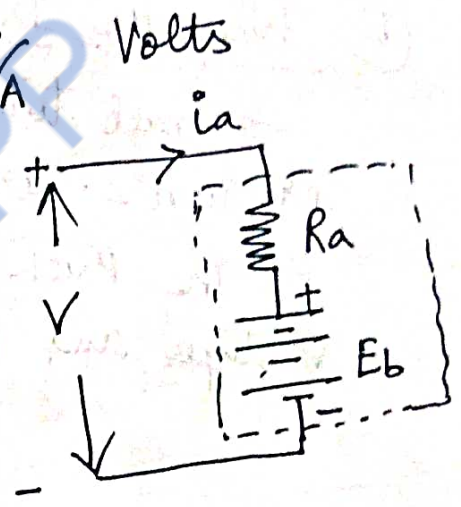

Here V ⇒ Applied voltage

Eb ⇒ Back EMF

Ia ⇒ Armature current

Ra ⇒ Armature Resistance

V - Eb ⇒ Net voltage in the armature circuit.

Motor Speed High → Back Emf Eb large → Armature current small

Motor Speed Low → Back Emf Eb low → Armature current more

Importance of Back EMF :-

→ The DC motor is a self regulating machine because the development of Back Emf makes the DC motor to draw as much as Armature current which is just sufficient to develop the required load torque.

$$\text{Armature Current } I_a = \frac{V - E_b}{R_a}$$

(I) When the DC motor is operating on No Load Condition
⇒ Small torque is required to overcome the friction & windage losses.

The Back Emf ' E_b ' is nearly equal to the Input voltage and armature current is small

$$E_b \approx V$$

(II) When the DC motor is operating ON LOAD Condition
Driving torque of the DC motor is not sufficient to counter the increased retarding torque due to load.
Armature slows down, E_b decreases and $I_a \uparrow$

The $I_a \uparrow$ makes Driving torque \uparrow and due to this the motor continues to slow down till the driving torque matches the load torque & steady state condition is reached.

(III) When the load on DC motor is decreased :-

The driving torque developed is momentarily in excess of the load requirement so that

(11)

motor armature is accelerated.

Motor speed \uparrow $E_b \uparrow$ $I_a \downarrow$
Motor Speed \downarrow $E_b \downarrow$ $I_a \uparrow$

The decrease in armature current causes decrease in driving torque and steady state conditions are reached, when the driving torque is equal to the load torque. Thus the E_b (Back EMF) of a DC motor regulates the armature current and it makes a motor self regulating.

VOLTAGE EQUATION OF DC MOTOR:-

$V \Rightarrow$ S/P Voltage

$E_b \Rightarrow$ Back emf

$R_a \Rightarrow$ Armature Resistance

$I_a \Rightarrow$ Armature Current

$I_{sh} \Rightarrow$ Shunt Field current

$R_{sh} \Rightarrow$ Shunt Field Resistance

line current $I_L = I_a + I_{sh}$

Here, the current flowing in the armature is given by

$$I_a = \frac{V - E_b}{R_a}$$

(or)

$$V = E_b + I_a R_a$$

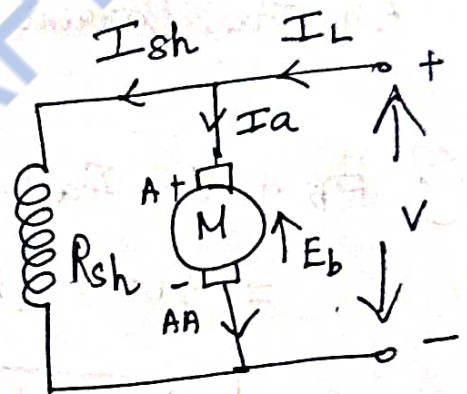

Problems :-

1. A DC motor connected to a 460V supply has an armature resistance of $0.15\ \Omega$. Calculate (a) value of back emf when the armature current is 120A. (b) the value of armature current when the back emf is 447V.

Solution :-

$$\text{Supply voltage } V = 460\text{V}$$

$$\text{Armature Resistance } R_a = 0.15\ \Omega$$

$$\text{Armature Current } I_a = 120\text{A}$$

To find

$$E_b \text{ at } I_a = 120\text{A}$$

$$I_a \text{ at } E_b = 447\text{V}$$

$$(a) E_b = V - I_a R_a$$

$$= 460 - (120)(0.15) = 460 - 18 = 442\text{V}$$

$$\boxed{E_b = 442\text{V}} \quad [\text{Back emf at } 120\text{A}]$$

(b)

$$I_a R_a = V - E_b$$

$$I_a = \frac{V - E_b}{R_a} = \frac{460 - 447}{0.15} = 86.67\text{A}$$

$$\boxed{I_a = 86.67\text{A}} \quad [\text{At } E_b = 447\text{V}]$$

TYPES OF DC MOTOR

- It is similar to DC generator in its classification
- Classification is based on the connections of field winding in relation to the armature.

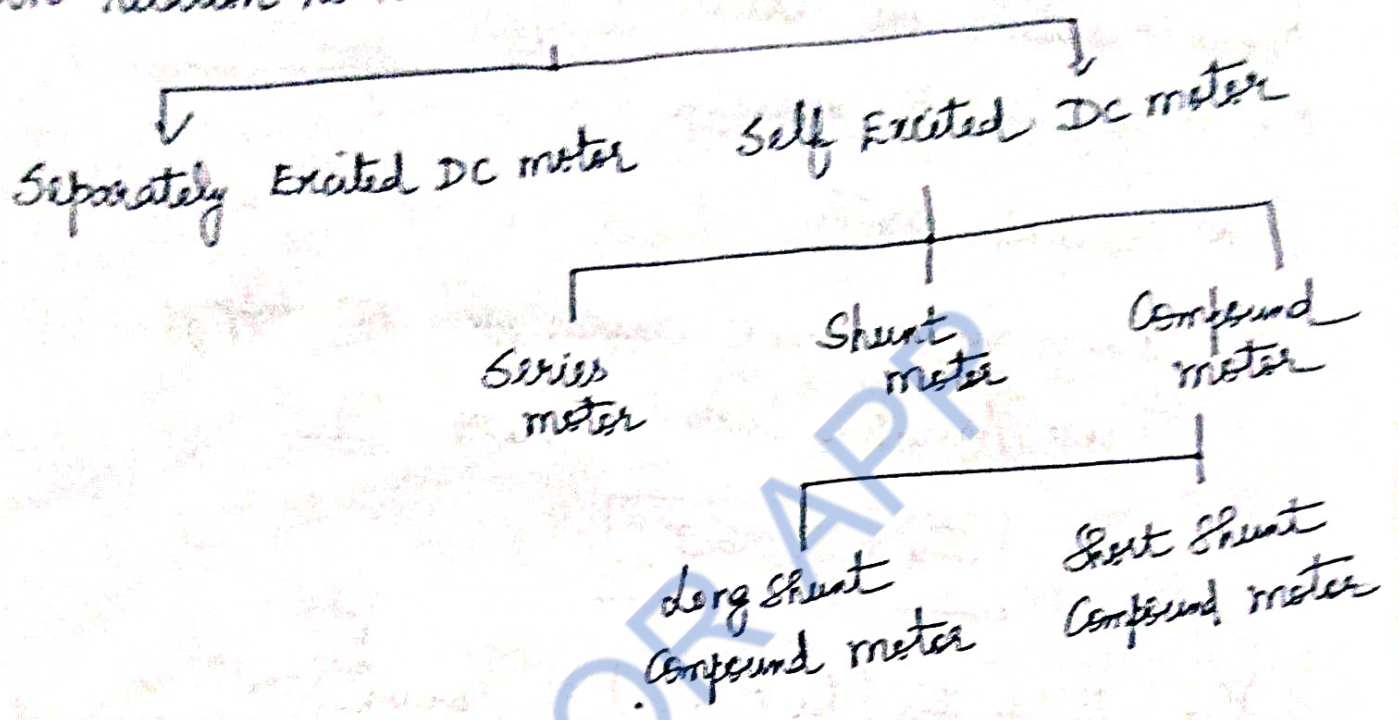

Separately Excited DC motor:

- ⇒ Field wdg and Armature Resistance are separated.
- ⇒ Field wdg is excited by a separate DC source.
- ⇒ That is why it is called Separately Excited DC motor.

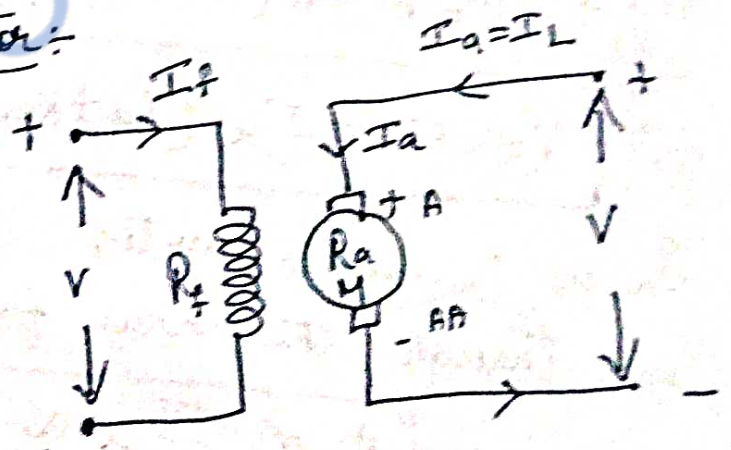

Armature current $I_a = \text{line current } I_L$

Back Emf $E_b = V - I_a R_a - V_{\text{brush}}$

V_{brush} is very small, can be neglected.

Self Excited DC motor :-

- ⇒ Field wdg connected in series with the armature
- ⇒ less wdg of thick wire
- R_{se} ⇒ Resistance in series
- R_{se} is very small normally.

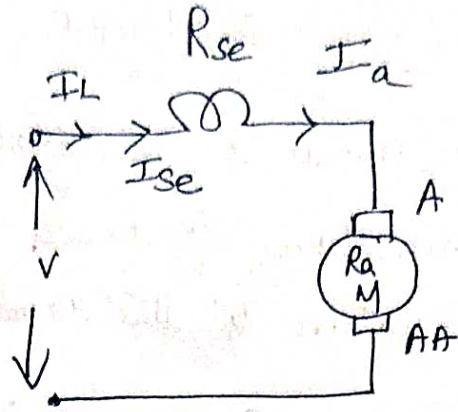

In a DC series motor,

I_L ⇒ line current drawn from the supply

I_a = Armature Current $I_{se} = I_L$

$$I_a = I_{se} = I_L$$

$$V = E_b + I_a (R_a + R_{se}) + V_{brush} \text{ (small \& can be neglected)}$$

$$\therefore V = E_b + I_a (R_a + R_{se})$$

In a DC series motor, full armature current flows through the series field winding

$$\phi \propto I_{se} \propto I_a$$

DC Shunt motor :-

- ⇒ Field winding is connected across the armature
- ⇒ Shunt field wdg has more number of turns with less cross-sectional area.

⇒ Shunt field wdg has more number of turns with less cross-sectional area.
 "Ra" Very small & "Rsh" Quite large.

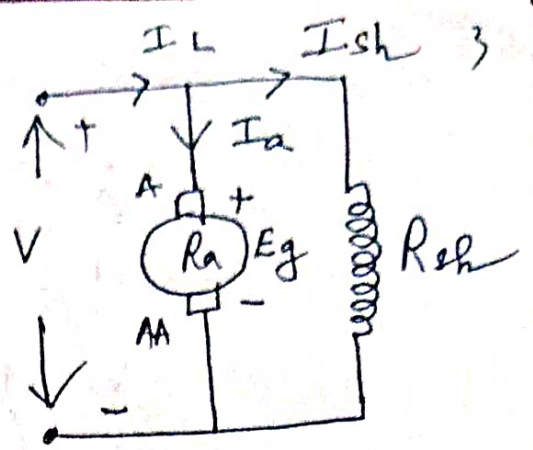

$$I_L = I_a + I_{sh}$$

I_a ⇒ Armature current
 I_{sh} ⇒ Shunt Field current

$$I_{sh} = \frac{V}{R_{sh}}$$

Voltage equation of a DC shunt motor is given by

$$V = E_b + I_a R_a + V_{brush}$$

In shunt motor, flux produced by field wdg is proportional to the field current I_{sh} .

$$\Phi \propto I_{sh}$$

If voltage is constant - Flux is constant

DC shunt motor is also called a Constant flux motor (or) constant speed motor.

DC Compound Motor:

⇒ Consist of both series & shunt field winding

② Long Shunt Compound motor :-

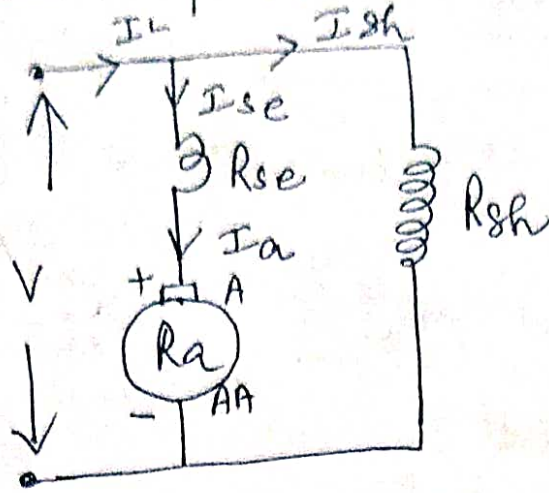

$$I_L = I_{se} + I_{sh}$$

$$I_{se} = I_a$$

$$I_L = I_a + I_{sh}$$

$$I_{sh} = \frac{V}{R_{sh}}$$

Voltage equation of this motor is given by

$$V = E_b + I_a R_a + I_{se} R_{se} + V_{brush}$$

Where $I_a = I_{se}$

$$\therefore V = E_b + I_a (R_a + R_{se}) + V_{brush}$$

Short Shunt Compound motor :-

$$I_L = I_{se}$$

$$I_L = I_a + I_{sh}$$

$$I_L = I_{se} = I_a + I_{sh}$$

The voltage across the shunt field wdg can be found out from the voltage equation

$$V = E_b + I_a R_a + I_{se} R_{se} + V_{brush}$$

$$I_{se} = I_L$$

$$V = E_b + I_a R_a + I_L R_{se} + V_{brush}$$

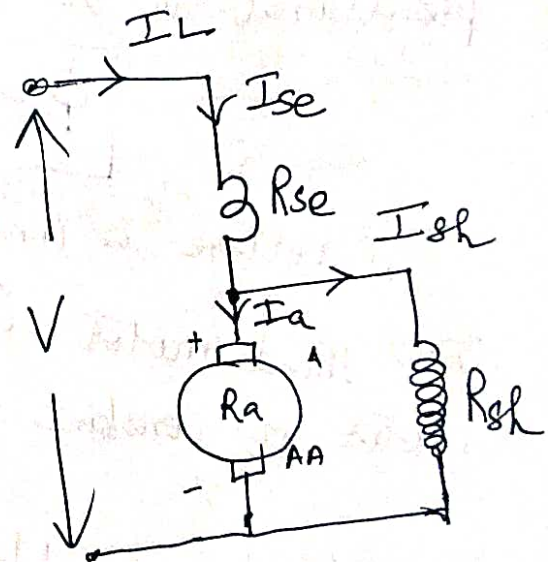

$$V = E_b + I_a R_a + I_L R_{se} + V_{brush}$$

Voltage drop across the shunt field wdg. is

$$V_{sh} = V - I_L R_{se}$$

$$V_{sh} = E_b + I_a R_a + V_{brush}$$

$$I_{sh} = \frac{V - I_L R_{se}}{R_{sh}}$$

The compound motor again can be classified into '2' types

Cumulative Compound motor

Differential Compound motor

Cumulative Compound

- Two field winding fluxes aid each other
- The flux due to the series field winding strengthens the flux due to the shunt field winding.

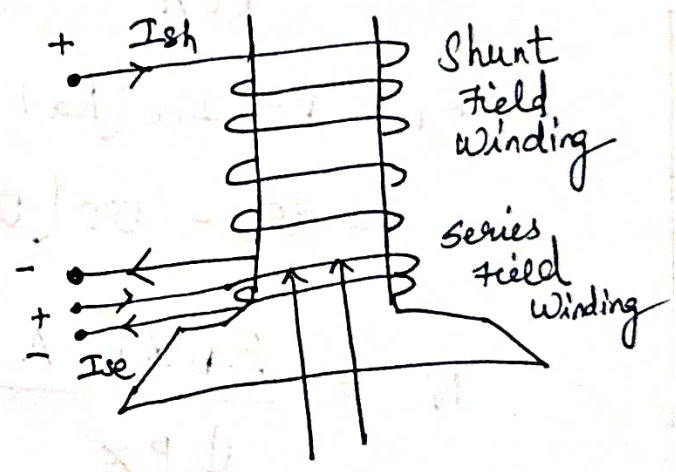

Differential Compound Motor

- ⇒ Fluxes opposes each other
- ⇒ Flux due to series field winding weakens the field due to shunt field winding

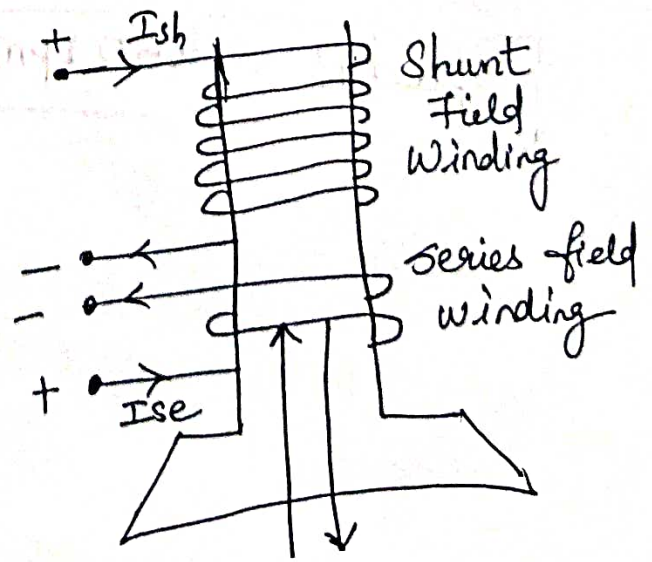

Problems:-

① A 4 pole, 250V series motor has a wave connected armature with 1254 conductors. The flux per pole is 22 mwb. The motor takes an armature current of 50A. Armature & field resistances are 0.2Ω & 0.2Ω respectively. Calculate its speed.

Sol

$$P = 4, V = 250V, Z = 1254 \text{ conductors}$$

$$\phi = 22 \text{ mwb}, I_a = 50A, R_a = 0.2\Omega$$

$$R_{se} = 0.2\Omega, \text{ for wave connected armature } A = 2.$$

$$E_b = \frac{\phi P N Z}{60 A}$$

$$E_b = V - I_a (R_a + R_{se})$$

$$= 250 - 50(0.2 + 0.2) = 250 - 20 = 230V$$

$$N = \frac{E_b \times 60 A}{\phi P Z} = \frac{(230)(60)(2)}{22 \times 10^{-3} \times 4 \times 1254}$$

$$\boxed{\text{Speed } N = 250 \text{ rpm}}$$

② A 10kW, 250V DC Shunt machine has an armature and field resistances of 0.1Ω & 125Ω respectively. Calculate the total armature power developed when running (i) as a motor taking 10kW input (ii) as a generator delivering 10kW as o/p.

Sol $V = 250V$, $P = 10kW$, $R_a = 0.1\Omega$ $R_{sh} = 125\Omega$

(i) Total armature power developed when running

(a) As a motor taking 10kW input.

Line current

$$I_L = \frac{P}{V}$$

Required Power $P_a = E_b I_a$

To find E_b

$$E_b = V - I_a R_a$$

To find I_a

$$I_a = I_L - I_{sh} \Rightarrow \text{To find } I_L \text{ \& } I_{sh}.$$

Line current $I_L = \frac{P}{V} = \frac{10 \times 10^3}{250} = 40A$

Shunt field current $I_{sh} = \frac{V}{R_{sh}} = \frac{250}{125} = 2A$

$$I_a = I_L - I_{sh} \Rightarrow 40 - 2 = 38A$$

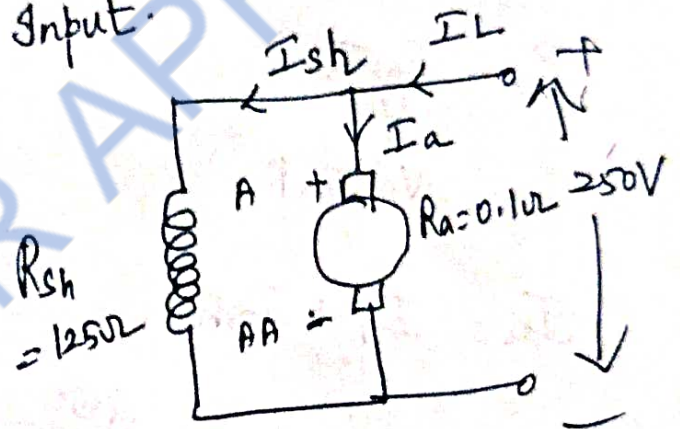

$$\text{Back EMF } E_b = V - I_a R_a$$

$$E_b = 250 - (38 \times 0.1)$$

$$E_b = 246.2 \text{ V}$$

Power developed in the armature

$$P_a = E_b I_a = (246.2)(38)$$

$$P_a = 9355.6 \text{ W}$$

(ii) As a generator delivering 10 kW o/p

$$P_a = E_g I_a$$

$$E_g = V + I_a R_a$$

$$I_a = I_L + I_{sh}$$

$$I_{sh} = \frac{V}{R_{sh}} = \frac{250}{125} = 2 \text{ A}$$

$$I_L = \frac{P}{V} = \frac{10 \times 10^3}{250} = 40 \text{ A}$$

$$I_a = I_L + I_{sh} = 40 + 2 = 42 \text{ A}$$

$$\text{Generated EMF } E_g = V + I_a R_a$$

$$= 250 + (42 \times 0.1)$$

$$= 254.2 \text{ V}$$

∴ Power developed in the armature

$$P_a = E_g I_a = (254.2)(42)$$

$$= 10676.4 \text{ W} \Rightarrow 10.67 \text{ kW}$$

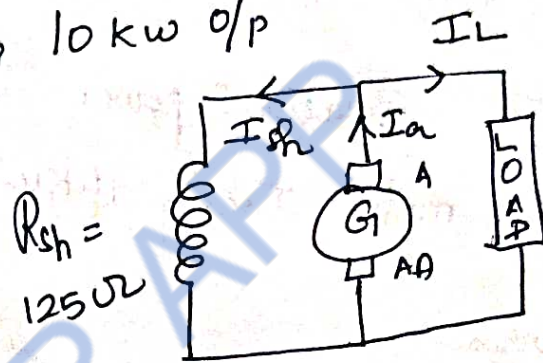

TORQUE EQUATION:

Torque is measured by the product of force and the radius at which the force acts.

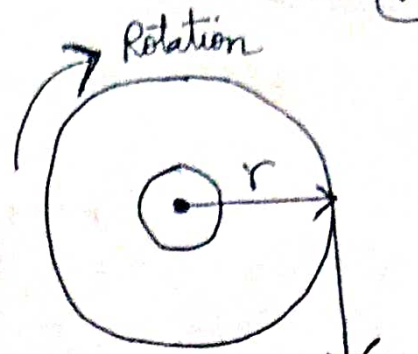

The angular velocity of the wheel is

$$\omega = \frac{2\pi N}{60} \text{ rad/sec}$$

$$\text{Torque } T = F \times r \quad \text{N-m}$$

$$\begin{aligned} \text{Work done/Revolution} &= F \times \text{Distance moved} \\ &= F \times 2\pi r \quad \text{Joules.} \end{aligned}$$

$$\text{Power Developed } P = \frac{\text{Work done}}{\text{time}} = \frac{F \times 2\pi r}{\text{time for 1 rev}}$$

$$P = \frac{F \times 2\pi r}{(60/N)}$$

$$P = (F \times r) \left(\frac{2\pi N}{60} \right)$$

$$\begin{aligned} \text{rpm} &= 60 \\ \text{rps} &= \frac{N}{60} \\ 1 \text{ rev} &= 60/N \end{aligned}$$

$$\boxed{P = T\omega \text{ Watts}}$$

Where $T \Rightarrow$ Torque in N-m
 $\omega \Rightarrow$ Angular Speed in rad/sec.

\Rightarrow The torque developed by a DC motor is obtained by looking at the electrical power supplied to it and mechanical power produced by it. It is also called Armature torque.

Power in armature $P_a = \text{Armature torque} \times \omega$

$$E_b I_a = T_a \times \frac{2\pi N}{60} \rightarrow (1)$$

$$\Rightarrow E_b = \frac{\phi P N Z}{60 A} \rightarrow (2)$$

Sub (2) in (1) we get

$$\frac{\phi P N Z I_a}{60 A} = T_a \cdot \frac{2\pi N}{60}$$

$$T_a = \frac{\phi I_a P Z}{(2\pi) (A)} = 0.159 \phi I_a \frac{P Z}{A} \text{ N-m}$$

$$T_a = 0.159 \phi I_a \frac{P Z}{A} \text{ N-m}$$

This is the torque equation of a DC motor.

$$T \propto \phi I_a$$

Torque of the given DC motor is proportional to the product of armature current & flux.

SHAFT TORQUE:-

\Rightarrow The torque developed by the armature is called Armature torque. (T_a)

\Rightarrow The full armature torque is not available for doing work.

⇒ Some amount of torque is used for supplying iron + friction losses in the motor. This torque is called **LOST TORQUE (T_f)**

⇒ It is used for doing useful work.

⇒ Also known as **Shaft Torque (or) Useful Torque (T_{sh})**

Armature Torque = lost Torque + Shaft Torque.

$$T_a = T_f + T_{sh}$$

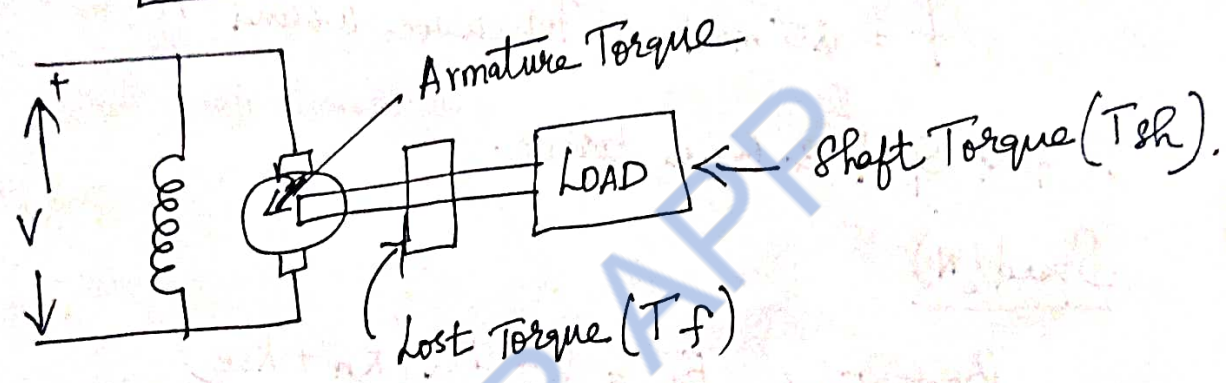

The output power of the motor is

$$P_{out} = T_{sh} \times \frac{2\pi N}{60} \text{ W}$$

$$T_{sh} = \frac{P_{out}}{2\pi N/60} \text{ N-m} \quad (\text{Where 'N' is in rpm})$$

$$= \frac{60}{2\pi} \frac{P_{out}}{N} \text{ N-m}$$

$$T_{sh} = 9.55 \frac{P_{out}}{N} \text{ N-m.}$$

Problems:-

① A 250V, 4 pole wave wound DC series motor has 782 conductors on its armature. It has armature and series

field resistance of 0.75Ω . The motor takes a current of 40 A . Determine its speed and Gross torque developed if it has a flux/pole of 25 mWb .

Sol $V = 250 \text{ V}$, $P = 4$, $Z = 782$

$$R_a + R_{se} = 0.75 \Omega$$

$$I_a = I_L = 40 \text{ A}$$

$$f = 25 \text{ mWb}, \text{ For wave wound } A = 2$$

To find Speed & Gross torque.

Speed (N)

$$\text{Back Emf } E_b = V - I_a (R_a + R_{se})$$

$$E_b = 250 - (40)(0.75) = 220 \text{ V}$$

$$E_b = \frac{P \phi Z N}{60 A} \Rightarrow N = \frac{E_b \cdot 60 A}{P \phi Z} = \frac{(220)(60)(2)}{4 \times 25 \times 10^{-3} \times 782}$$

$$N = 337.6 \text{ rpm}$$

Gross Torque (T_a)

$$T_a = 0.159 \cdot \frac{\phi I_a P Z}{A}$$

$$= \frac{(0.159)(25 \times 10^{-3})(40 \times 4)(782)}{2}$$

$$T_a = 248.61 \text{ N-m}$$

APPLICATIONS OF DC MOTOR:

- DC shunt motors are used where the speed has to remain nearly constant with load and where a high starting torque is not required
- Used for driving Centrifugal pumps and light machine tools, wood working machines, lathe etc.
- Series motors → load is directly attached to the shaft or through a gear arrangement & hence no danger of the load being "thrown off".
- ⇒ Used in Electric trains → Self weight of trains acts as load
- ⇒ Used in Cranes, hoists, fans, blowers, Conveyers, lifts
- ⇒ Where starting torque requirement is high
- ⇒ Compound motors are used for driving heavy machine tools for intermittent loads, shears, punching machines etc.

TYPE

TRANSFORMER.

- ⇒ Works on the principle of electromagnetic Induction
- ⇒ A transformer is an electrical device having no moving parts, ~~which~~ by which mutual Induction transfers electric energy from one circuit to another at the same frequency usually with change in values of voltage and current.
- ⇒ It consist of '2' windings insulated from each other and wound on a common core made up of magnetic material
- ⇒ The AC voltage is connected across one of the winding called the PRIMARY WINDING.
- ⇒ The second winding is called the SECONDARY WINDING.

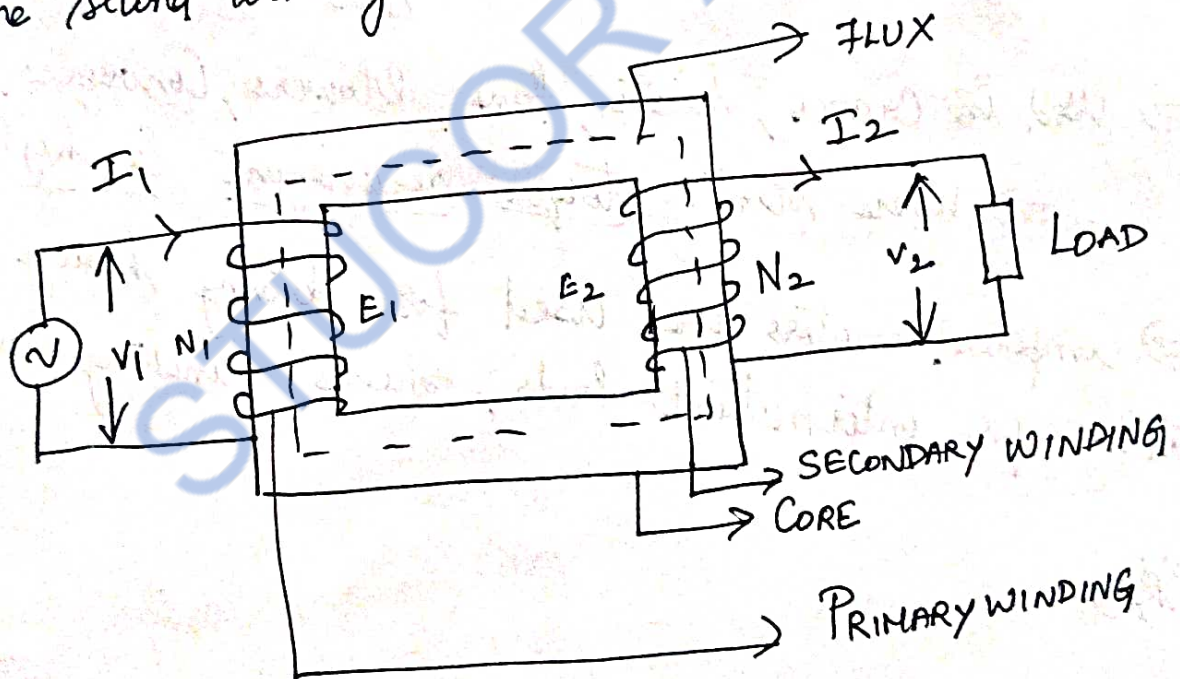

Transformer - Cross-section

CLASSIFICATION OF TRANSFORMERS

(i) Duty they perform

- Power transformer - for transmission & Distribution purposes
- Current transformer - Instrument transformers
- Potential transformer - Instrument transformers.

(ii) Construction

- Core type
- Shell type
- Berry type

(iii) Voltage output

- Step down transformer (Higher to lower)
- Step up transformer (lower to higher)
- Auto transformer (variable from '0' to rated value)

(iv) Applications

- welding transformer
- Furnace transformer

(v) Cooling

- Duct type (Air natural (or) Air Blast)
- oil Immersed
 - self cooled
 - Forced air cooled
 - Water cooled
 - Forced oil cooled

(vi) I/P Supply

- 1 ϕ
- 3 ϕ
- Star-Star
- Star-Delta
- Delta-Star
- Delta-Delta
- Open-Delta
- Scott Connection

CONSTRUCTION DETAILS

→ A transformer is a static device and its construction is simple as there are no moving parts.

COMPONENTS OF A TRANSFORMER:-

- ⇒ Magnetic core
- ⇒ Primary & Secondary windings
- ⇒ Insulation of windings.
- ⇒ Expansion tank or Conservator.
- ⇒ Lead & tappings for coils with their supports, terminals and terminal insulators.
- ⇒ Tank, oil, cooling arrangement, temperature gauge, oil guage
- ⇒ Buchholz relay
- ⇒ Silica Gel breather.

Magnetic Core :-

- ⇒ Iron core
- ⇒ Transformer core is laminated (Silicon Steel)
- ⇒ Thickness of lamination varies from 0.35 mm to 0.5 mm

Two types of transformer core

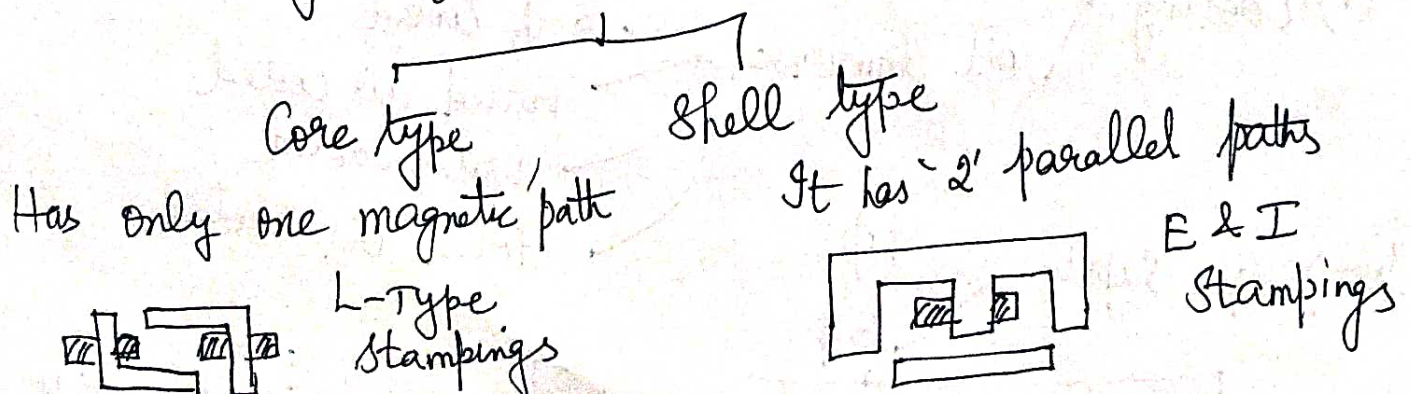

Windings \rightarrow 2 wdg's in a transformer made of copper
 Primary Secondary ,

Insulation

Paper \Rightarrow Basic insulator

Enameled \Rightarrow inter turn insulation for low voltage transformer

Enameled copper with paper insulation

\Rightarrow For power transformer

Insulating oil:

\Rightarrow Protects paper from dirt & moisture

\Rightarrow Removes the heat produced in the core & coils

Expansion Tank (or) Conservator:

\Rightarrow Keeps the transformer tank full of oil despite of expansion (or) contraction of the coil with temperature change

Temperature Gauge \rightarrow Indicate hot oil (or) hottest spot temperature

Oil Gauge \Rightarrow Indicate oil level present inside the tank

Buchholz Relay \Rightarrow Indicate the presence of bubbles in the oil

Bushings \Rightarrow Connections from the transformer windings are brought out by means of bushings

Cooling arrangement in Transformers.

- ⇒ Oil immersed natural cooled transformers
- ⇒ Oil immersed forced air cooled transformers.
- ⇒ Oil immersed water cooled transformers
- ⇒ Oil immersed forced oil cooled transformers
- ⇒ Air Blast transformers.

Working Principle of a Transformer:-

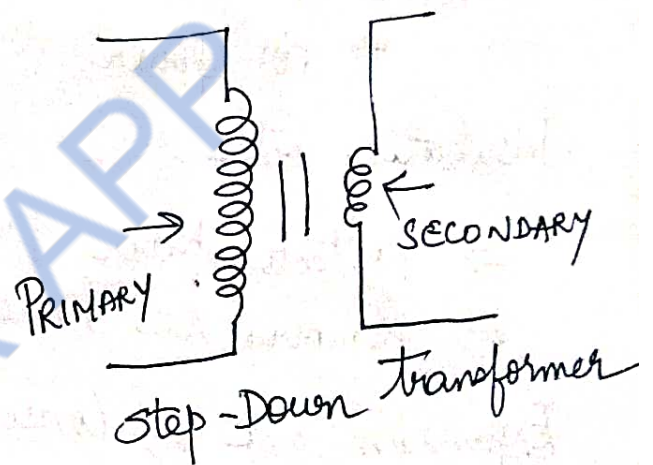
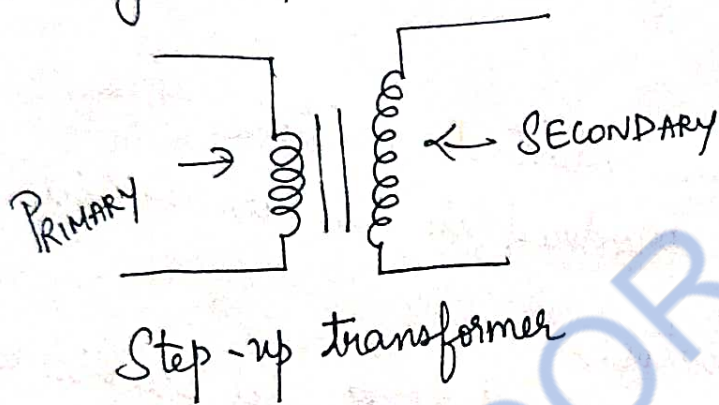

Applications:-

- ⇒ Electrical power Engineering for transmission & Distribution
- ⇒ As an instrument transformer for measuring current (C.T) and measuring voltage (P.T)
- ⇒ Step up & Step down transformers to make the output voltage to be increased (or) reduced.
- ⇒ Radio & TV circuits, telephone circuits, control & instrumentation circuits
- ⇒ Furnaces & welding transformer.

Working Principle of transformer:

- The transformer works on the principle of electromagnetic induction.

- Transformer is an electrical machine which transfer electrical energy from one circuit to another circuit at the same frequency by mutual induction.

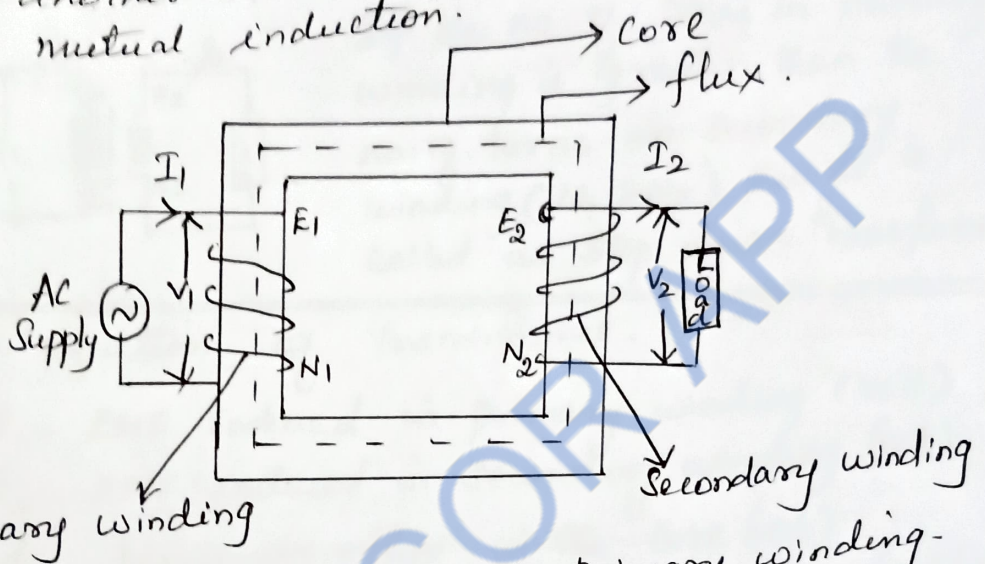

- AC Source is connected to primary winding.
- Exciting current flows through the primary winding.
- Alternating magnetic flux is produced in the core which link both primary and secondary winding.
- By self induction principle, EMF is induced in the primary winding (E_1)
- By mutual induction principle, EMF is induced in the secondary winding (E_2)
- If load is connected in the secondary circuit, current flows through the secondary winding.
- The magnitude of emf induced in secondary winding depend upon the no. of turns
- N_1 - No. of turns in primary winding.
- N_2 - No. of turns in secondary winding.

Step up transformer:

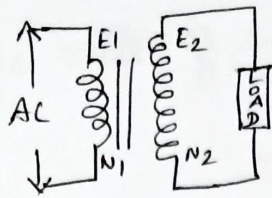

If the no. of turns in secondary winding is greater than the no. of turns in primary winding ($N_2 > N_1$), then it is called as step up transformer.

Step down transformer:

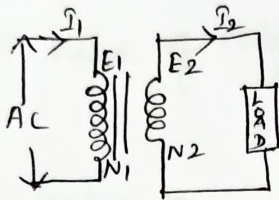

If the no. of turns in primary winding is greater than the no. of turns in secondary winding ($N_1 > N_2$) then it is called as step down transformer.

EMF equation of Transformer:

- E_1 - EMF induced in primary winding (volt)
- E_2 - EMF induced in secondary winding (volt)
- ϕ_m - Maximum flux in the core (wb)
- B_m - Maximum flux density in the core (wb/m^2)
- I_1 - full load primary current
- I_2 - full load secondary current
- N_1 - No. of turns in primary winding.
- N_2 - No. of turns in secondary winding
- A - Area of the core in m^2
- F - Frequency of AC supply.

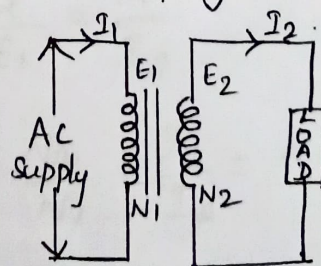
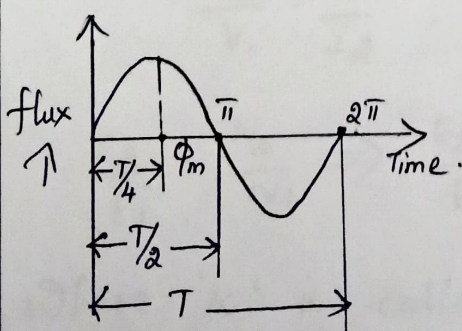

- At time " $T/4$ " sec, flux is maximum (ϕ_m)
- WKT $T = \frac{1}{f}$

According to Faraday's law of electromagnetic induction

$$\begin{aligned} \text{Average rate of change of flux} &= \frac{\Phi_m \omega \text{wb/sec}}{\frac{1}{4}f} \\ &= \Phi_m \times \frac{4f}{1} = 4f \Phi_m \dots \text{VOLT} \end{aligned}$$

$$\text{Form factor} = \frac{\text{RMS}}{\text{Average Value}} = 1.11.$$

$$\begin{aligned} \text{RMS Value of emf induced/turn} &= 1.11 \times 4f \Phi_m \\ &= 4.44 f \Phi_m \end{aligned}$$

RMS Value of emf induced in P_y wdg

$$E_1 = 4.44 f \Phi_m N_1$$

$$E_1 = 4.44 f B_m A N_1$$

$$\begin{aligned} B_m &= \frac{\Phi_m}{A} \\ \Phi_m &= B_m A \end{aligned}$$

RMS Value of emf induced in S_y wdg

$$E_2 = 4.44 f \Phi_m N_2$$

$$E_2 = 4.44 B_m A f N_2$$

Transformation Ratio

for ideal transformer

$$V_1 = E_1, \quad V_2 = E_2$$

$$V_1 I_1 = V_2 I_2, \quad E_1 I_1 = E_2 I_2$$

$$\frac{V_2}{V_1} = \frac{I_1}{I_2}, \quad \frac{E_2}{E_1} = \frac{I_1}{I_2}$$

$$\frac{E_2}{E_1} = \frac{N_2}{N_1} \Rightarrow \frac{E_2}{E_1} = \frac{N_2}{N_1} = \frac{I_1}{I_2} = k$$

Where 'k' is called transformation ratio

THREE PHASE ALTERNATORS (SYNCHRONOUS GENERATOR)

Fundamental principle of electromagnetic Induction as like DC generator

When the flux linking a conductor changes, an emf is induced in the conductor.

In alternator, armature wdg. is mounted on a stationary element called STATOR.

Field wdg. is on a rotating element called ROTOR.

Advantages

- Better Insulation
- Ease of current collection
- Increased armature tooth strength
- More rigid construction
- ⇒ Reduced armature leakage reactance
- ⇒ lesser number of slip rings
- ⇒ lesser rotor weight and inertia
- ⇒ Improved ventilation & heat dissipation.

CONSTRUCTION OF ALTERNATOR:-

Stator → Stationary part with laminations
⇒ $A3\phi$ bldg is placed in these slots

ROTOR ⇒ Carries Field wdg which is supplied with DC through '2' slip rings by a separate DC source.

- 2 Types
- Salient pole (or) Projecting pole type
 - Non-salient pole (or) cylindrical type.

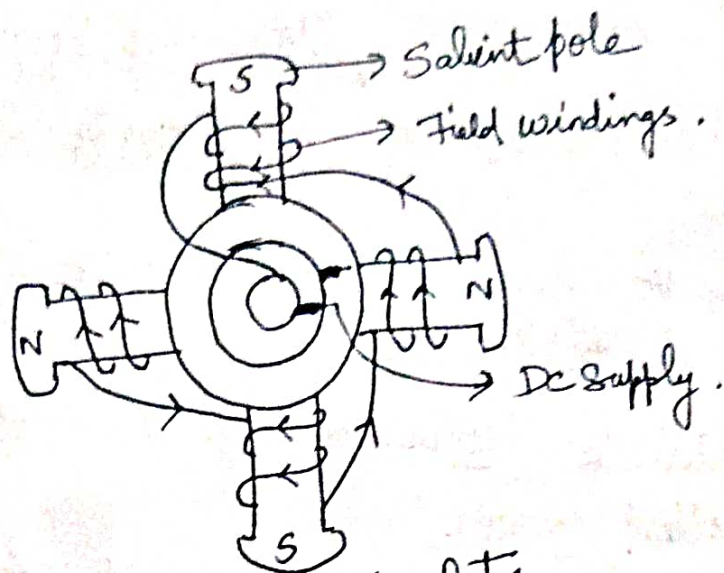

Salient pole rotor

- ⇒ Used for slow and moderate speed alternators
- ⇒ Can't be employed in high speed generators
- ⇒ Salient poles made of thick steel laminations
- ⇒ The pole faces are usually provided with slots for Damper windings → used in preventing hunting.

Special features :-

- ⇒ Large diameter & short axial length
- ⇒ Pole shoes cover about $\frac{2}{3}$ of pole pitch
- ⇒ Poles are laminated to reduce eddy current losses.
- ⇒ Employed with hydraulic turbines or diesel engines
Speed is from 120 to 400 rpm.

SMOOTH CYLINDRICAL (or) NON-SALIENT POLE TYPE :-

- ⇒ Used in high speed alternators
- ⇒ Diameter is reduced, axial length is increased

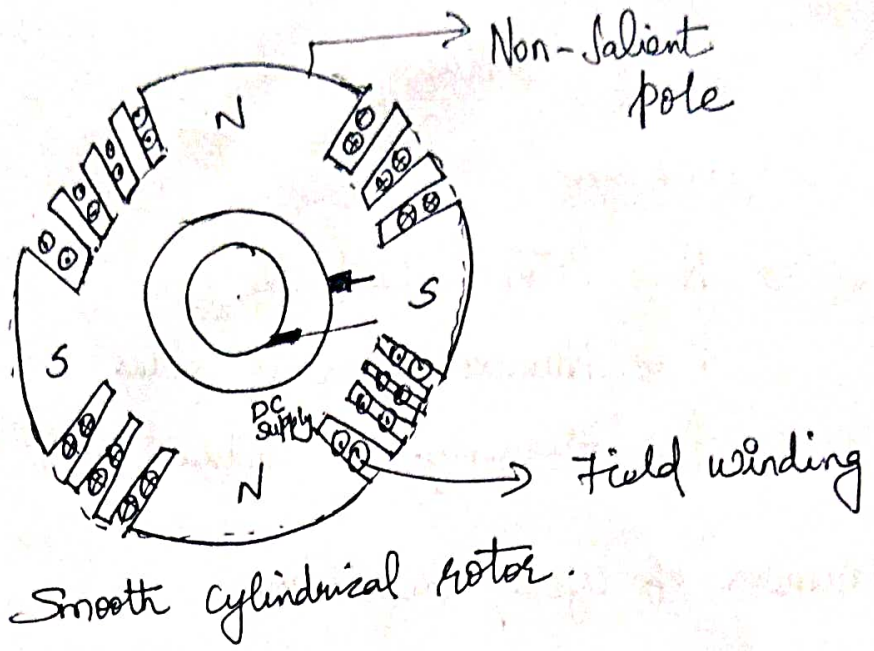

Features

- ⇒ Small diameter & very long axial length
- ⇒ less windage loss
- ⇒ Speed range is from 1,000 to 3,000 rpm
- ⇒ Better in dynamic balancing and quieter in operation
- ⇒ No need of Damper windings

Working of Alternator :-

As the rotor rotates, the armature conductors are cut by the magnetic flux. Hence an emf is induced in the armature conductors.

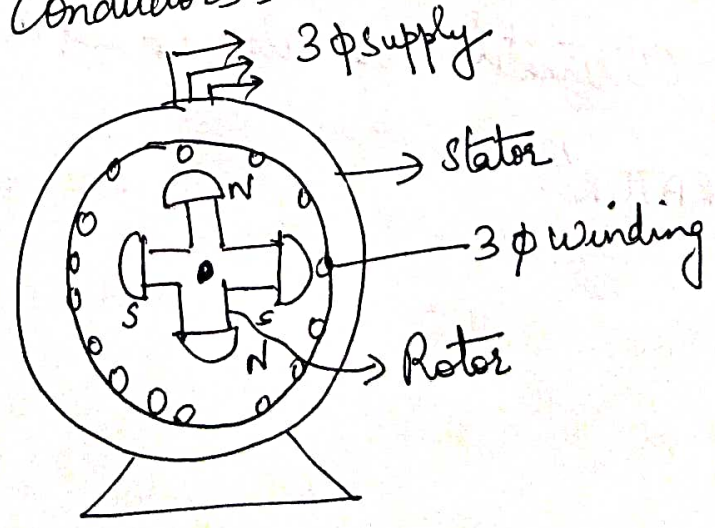

Frequency of Induced emf :-

Depends on

$\Rightarrow N \Rightarrow$ Rotor speed in rpm

$P \Rightarrow$ Number of Rotor poles

$f \Rightarrow$ Frequency of induced emf in Hz.

Number of cycles/ Revolution

$$= \text{No. of pairs of poles} = P/2$$

$$\text{No. of revolutions/sec} = N/60$$

$$\text{No. of cycles/sec} = \left(\frac{P}{2}\right) \left(\frac{N}{60}\right) = \frac{PN}{120}$$

$$\text{Frequency } f = \frac{PN}{120}$$

⊗ The alternators must run at Synchronous speed to give an o/p of desired frequency.
Hence alternators are also called as "SYNCHRONOUS GENERATOR".

PROBLEMS:-

(i) A 415V, 4 pole, 3φ alternator is driven at 1500rpm. Calculate the frequency of operation.

Given

- P = 4
- N = 1500rpm
- V = 415V

$$f = \frac{PN}{120} = \frac{(4)(1500)}{120} = 50\text{Hz}$$

$f = 50\text{Hz}$

Compare Salient pole Rotor & Smooth cylindrical rotor.

Salient Pole Rotor

- (1) Large diameter & short axial length
- (2) used for low speed alternators
- (3) Has projecting poles
- (4) Needs Damper windings
- (5) More Windage loss

Smooth cylindrical Rotor

- (1) small diameter & long axial length
- (2) Used for high-speed alternators
- (3) No projecting poles
- (4) Doesn't need Damper windings
- (5) less Windage loss.

SYNCHRONOUS MOTOR :

⇒ A type of 3 ϕ AC motors which operate at constant speed from No load to full load.

⇒ Used to improve the power factor for 3 ϕ AC Industrial Circuits.

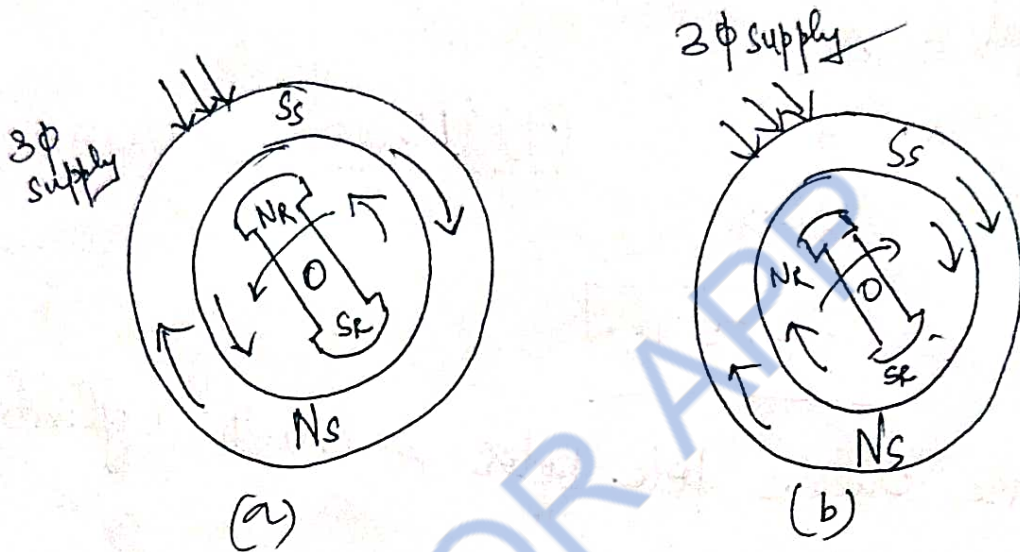

When a 3 ϕ supply is given to a 3 ϕ wdg, a magnetic field of constant magnitude but rotating at a constant speed, N_s is produced.

When ' N_s ' and ' N_r ' are together, like poles repel each other. Hence when N_s & S_s are moving in clockwise direction N_r & S_r are moving in anticlockwise direction S_s and N_r gets attracted and the rotor tries to rotate in clockwise direction.

Thus rotor experiences torque in different directions every half a cycle, Hence Rotor is at standstill due to large inertia.

⊗ "SYNCHRONOUS MOTOR HAS NO STARTING TORQUE AND CANNOT START BY ITSELF"

24

But it starts working as a motor if it is started by some means.

STARTING METHODS OF SYNCHRONOUS MOTORS :-

⇒ By using DC source.

Synchronous motor is coupled & started by means of DC compound motor. The speed of the DC motor is adjusted by the speed regulator. The synchronous motor is then excited and synchronized with AC supply mains.

Thus the synchronous machine is operating as a motor from AC mains & DC machine acts as load on it.

By Means of Pony Motor (Small AC motor)

⇒ A small direct coupled induction motor called the PONY MOTOR, may be used for starting the synchronous motor unless the motor is required to start against the full load torque.

Before switching on the AC supply to the synchronous motor, it must be synchronized with the bus-bars. Once the rotor attains synchronous speed, DC excitation is given to rotor.

At once synchronism is achieved, the pony motor is decoupled from the synchronous motor. This method is rarely used & not suited for industrial applications.

Modern machines are usually of self starting type and are arranged to start as induction motor.

By means of Damper Grids in the pole Faces:-

⇒ Synchronous motor is made self-starting by using a special winding on the rotor pole, known as Damper winding (or) Squirrel cage winding.

The Damper winding consist of short circuited copper bars which are placed in the face of field poles.

At starting, synchronous motor provided with damper winding starts as Squirrel cage Induction motor, when the AC supply is given to the stator.

Once the motor is given excitation, the motor runs at sub-synchronous speed. Then the DC supply is applied to the field winding. After sometime, the motor gets locked into synchronism and starts to run at synchronous speed & hence the relative speed between damper winding and rotating magnetic field is zero. After that, the damper is disconnected from the circuit.

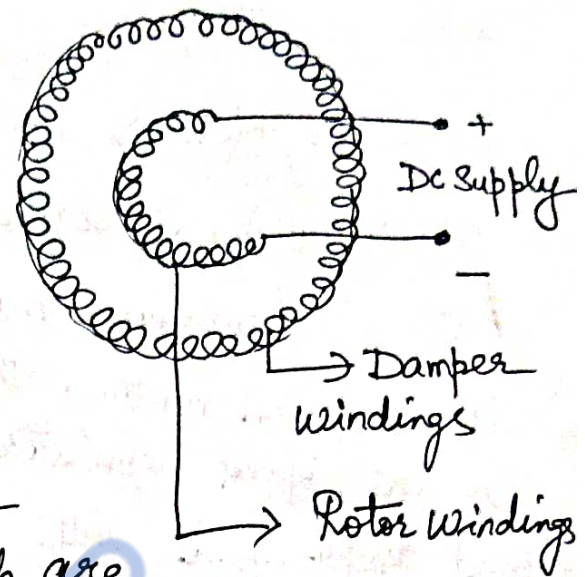

As a Slip Ring Induction motor

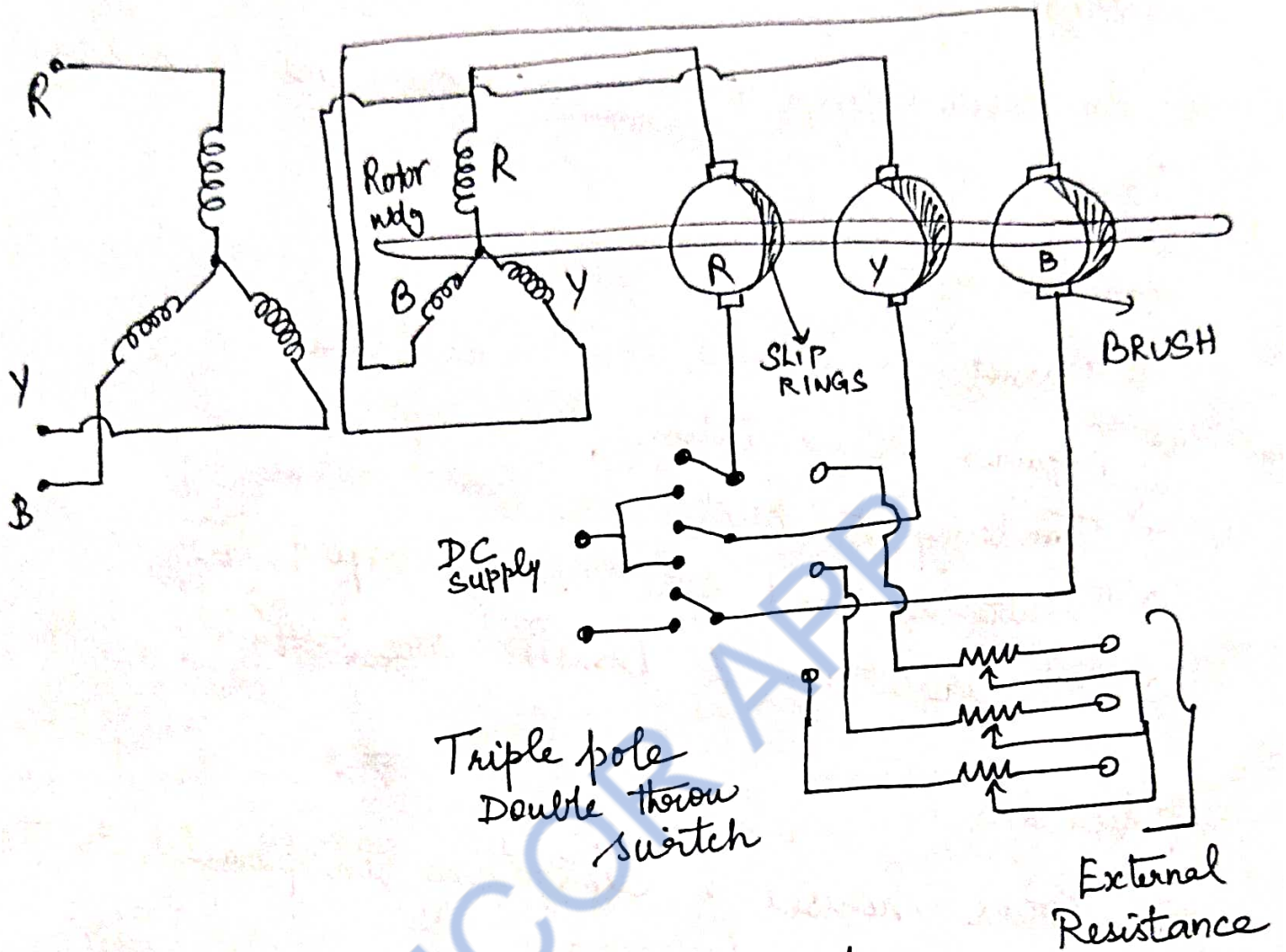

⇒ In order to obtain high starting torque, the synchronous motor can be started as slip ring induction motor. It is achieved by forming damper windings as STAR (OR) DELTA connected winding instead of just making them as short circuited wdg.

Advantages :-

- ⇒ Speed is constant & independent of load
- ⇒ Motor usually operated at higher efficiencies
- ⇒ Electromagnetic power varies linearly with voltage
- ⇒ Motor can be constructed with wider air gaps

than Induction motors which makes mechanically strong

⇒ An over excited synchronous motor having a leading PF

Disadvantages:

⇒ Cannot be started under load

⇒ Requires DC excitation

⇒ Tendency to hunt

⇒ Cannot be used for variable speed jobs

⇒ Collector rings & brushes are required

Applications

⇒ Power houses & substations in parallel to the Bus-Bars, to improve PF

⇒ Used to regulate the voltage at the end of the transmission lines.

⇒ In factories, having large number of Induction motor they are employed to improve P.f

⇒ The High Speed synchronous motors are such drive as fans, Blowers, DC generators, line shafts, Centrifugal pumps, compressors, Reciprocating pumps, constant speed frequency changers, rubber and paper mills etc.

THREE PHASE INDUCTION MOTORS.

(26)

Squirrel cage Induction motor

Wound Rotor (or) Slip Ring Induction motor.

CONSTRUCTION

It has '2' main parts

- ① stator
- ② Rotor

Stator:-

- ⇒ Made up of Stampings with alternate slot and tooth
- ⇒ Stampings are insulated from each other
- ⇒ Each stamping is 0.4 to 0.5 mm thick.
- ⇒ The 3 ϕ wdg is called "Stator winding" may be connected in star or Delta
- ⇒ The stator windings has fixed number of poles.

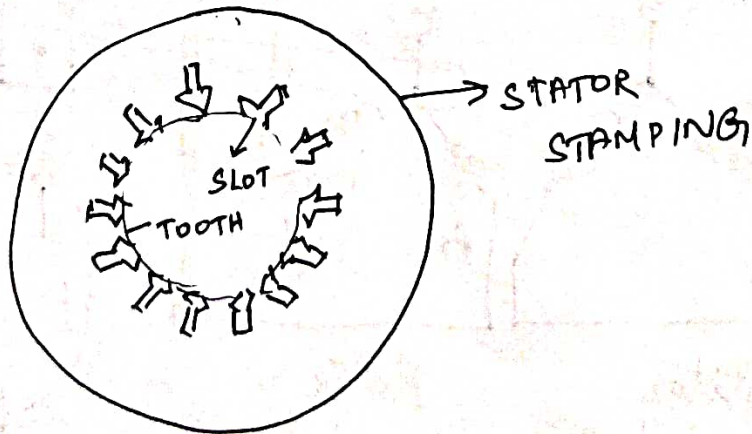

ROTOR $\left\{ \begin{array}{l} \text{Squirrel cage Rotor} \\ \text{Slip Ring (or) wound Rotor.} \end{array} \right.$

Squirrel Cage Rotor :

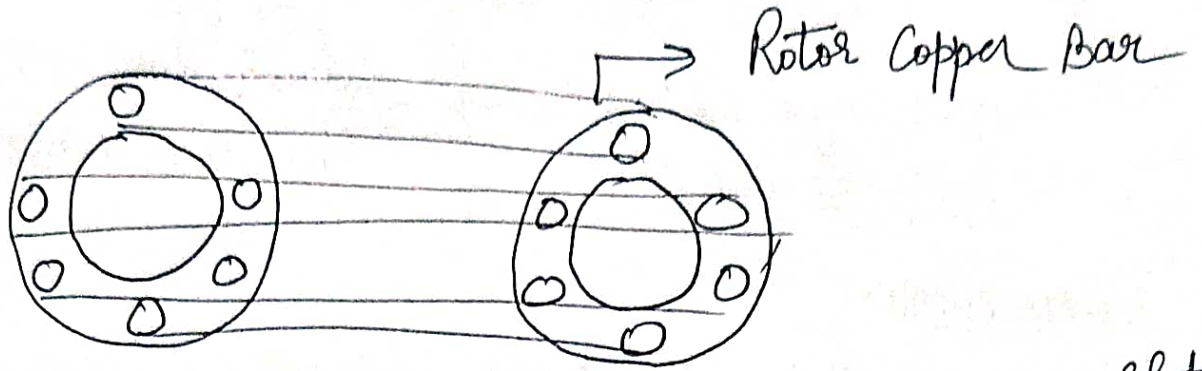

- ⇒ Made up of cylindrical laminated core with slots to carry rotor conductors
- ⇒ The rotor conductors are heavy bars of copper (or) aluminium short circuited at both ends by END RINGS
- ⇒ External Resistance cannot be connected in the rotor circuit

SLIP RING (OR) WOUND ROTOR :-

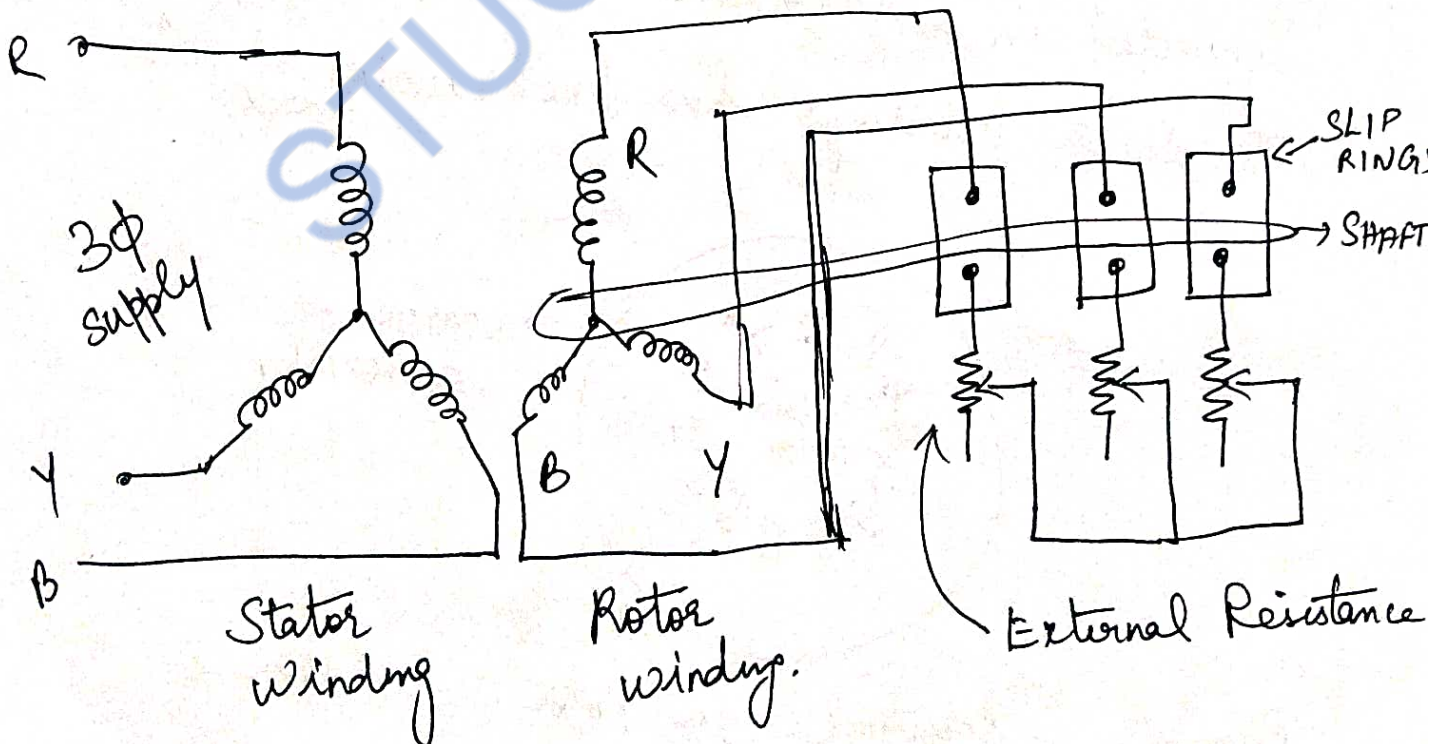

→ Rotor wdg similar to stator winding which may be star connected (or) Delta connected (27)

⇒ Variable external Resistance can be connected in the rotor circuit with the help of brushes & slip ring arrangements.

PRINCIPLE OF OPERATION:-

⇒ 3 ϕ supply is given to the stator winding

⇒ Due to this current flows through the stator wdg and it is called stator current.

$$N_s = \frac{120f}{P}$$

Where

N_s ⇒ Synchronous speed

f ⇒ Supply frequency

P ⇒ Number of poles for which the stator is wound.

In an Induction motor, the rotor speed is always less than the synchronous speed.

$$\text{Slip Speed} = \left\{ \begin{array}{c} \text{Synchronous Speed} \\ (N_s) \end{array} \right\} - \left\{ \begin{array}{c} \text{Rotor Speed} \\ N \end{array} \right\}$$

$$\text{Slip Speed} = N_s - N$$

$$\text{Slip } S = \frac{N_s - N}{N_s}$$

$$\Rightarrow N = N_s (1 - S)$$

$$\% \text{ Slip} = \frac{N_s - N}{N_s} \times 100$$

At No-load, the difference between synchronous speed and rotor speed is only about 1%.

Under steady state conditions, the electromagnetic torque is equal to the load torque.

At full load conditions, the difference between the synchronous speed and rotor speed is about 3 to 5%.

3 ϕ Induction motor is also called Constant Speed motor.

Advantages :- (Squirrel cage)

- ⇒ Cheaper
- ⇒ Light weight
- ⇒ Rugged construction
- ⇒ More Efficient
- ⇒ Requires less maintenance
- ⇒ Can be operated in dirty & explosive environment

Disadvantages :- (Squirrel cage)

- ⇒ Moderate Starting torque
- ⇒ External Resistance cannot be connected in Rotor circuit. So starting torque can't be controlled

Applications

⇒ Used in Lathes, Drilling machines, fans, Blowers, Water Pumps, Grinders, Printing machines etc

Advantages (Slip Ring Induction motor)

- ⇒ Starting torque can be controlled by varying the rotor circuit resistance
- ⇒ Speed of the motor can also be controlled by varying the rotor circuit resistance.

Disadvantages:

- ⇒ Wound-Rotor machine is heavier
- ⇒ High Cost
- ⇒ High Rotor inertia
- ⇒ High Speed limitation
- ⇒ Maintenance & Reliability problems occurs due to brushes & Slip Ring

Applications

⇒ Employed only when speed control (or) High starting torque is required

Eg: lifts, Hoists, Cranes, Elevators, Compressors etc.

PROBLEMS:-

① A 6-pole, 3 ϕ Induction motor is connected to 50Hz supply. If it is running at 970rpm, find the slip

Solution:-

$$P = 6, f = 50\text{Hz}, N = 970\text{rpm.}$$

$$\text{Synchronous Speed } N_s = \frac{120f}{P} = \frac{120 \times 50}{6} = 1000\text{rpm}$$

$$\text{Slip } S = \frac{N_s - N}{N_s} \times 100 \Rightarrow \frac{1000 - 970}{1000} \times 100$$

$$S = 0.03 \text{ (or) } 3\%$$

② A 4-pole, 3 ϕ Induction motor operates from supply whose frequency is 50Hz. Calculate (i) Speed of the stator magnetic field (ii) Speed of the rotor when the slip is 0.04.

Sol $P = 4, f = 50\text{Hz}, S = 4\% \text{ (or) } 0.04$

N_s (Synchronous speed)

$$N_s = \frac{120f}{P} = \frac{120 \times 50}{4}$$

$$N_s = 1500\text{rpm}$$

Speed of the motor (N)

$$N = N_s (1 - S)$$

$$N = 1500 (1 - 0.04)$$

$$N = 1440\text{rpm}$$

STUCOR APD

ANALOG ELECTRONICS

3.1 INTRODUCTION

Electronic components

» Electronic components are classified into active and passive components.

» Active components supply energy to the circuit

Example: Battery, semiconductor devices etc.

» Passive components consume energy from the source.

Example: Resistors, capacitors, inductors etc.

Resistors (R)

» R is an electrical/electronic component used to limit the flow of current.

» Unit is ohm (Ω)

» Symbol:



» $R = \frac{V}{I}$ (By Ohm's law)

» $R = \frac{\rho l}{A}$

where R → Resistance in ohm

ρ → Resistivity of the wire in ohm-cm

l → Length of the wire in cm.

Inductor (L)

It is used to store the energy in the form of magnetic energy, when electricity is applied to it. The SI unit of inductor is Henry (H).

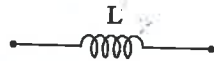

$$L = \frac{\phi(i)}{i}$$

where L → Inductance.

$\phi(i)$ → Magnetic flux of current.

i → Current

Capacitor

Capacitor is used to store the energy in the form of electrical energy charge producing a potential difference across the plates. S.I unit of capacitor is Farad (F)

$$C = \frac{\epsilon_0 \epsilon_r A}{d}$$

where C → Capacitance of a capacitor

ϵ_0 → Permittivity of free space

ϵ_r → Permittivity of dielectric medium

d → Distance between plates

A → Area of two conducting plates

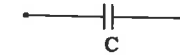

Fig.

$$C = \frac{Q}{V}$$

where Q → Charge

V → Voltage

3.1.1 Conductors

Atom

Atom is a Greek word and its means a particle, so atom is smallest particle of the matter, which has properties of element. E.g. Iron, Al, cu, etc

Atomic structure

An atom is the smallest particle of an element that retains the characteristics of that element. According to the classical Bohr model, atoms have a planetary type of structure that consists of a central nucleus surrounded by orbiting electrons. The nucleus consists of positively charged particle called protons and uncharged particles called neutrons. A short description about these particles is given below.

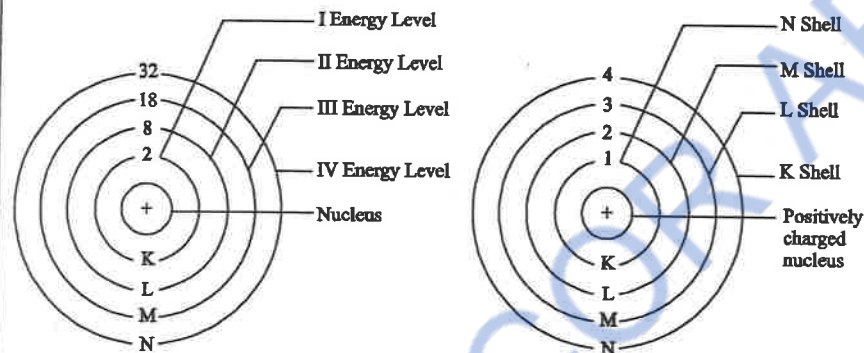

Fundamental particles of the atom

1. Electron
2. Proton
3. Neutron

1. Electron

It is a fundamental particle of the atom. Electron is a particle which has negative charge. The amount of the charge is -1.6×10^{-19} coulomb. Mass of electron is 9.11×10^{-31} kg or 0.00054859 a.m.u. Since atom has equal number of electrons and protons, they have equal and opposite charges hence effect and atom becomes neutral. It is 1836 times lighter than proton. It is revolving around the nucleus.

2. Proton

Proton is a particle which has positive charge. It is inside the nucleus. The amount of charge is 1.6×10^{-19} coulomb. The mass of proton is 1.67×10^{-27} kg or 1.0072766 a.m.u. It is 1836 times heavier than electron. The number of protons and electrons are equal in an atom.

3. Neutron

Neutron is a neutral particle thus it has no any charge. Hence the name neutron is derived from the word neutral. It is heavier than electron. It's mass is nearly equal to the mass of proton that is equal to 1.6×10^{-27} kg or 1.0086654

a.m.u. It is 1842 times heavier than electron. Both the proton and neutron make the atomic mass of the atom. It resides inside the nucleus.

3.1.2 Electronic configuration

We know that electron is revolving around the nucleus in different position. These positions are called energy levels or shell electrons are distributed among the shell according to $2(N)^2$ formula.

The number of electron in K shell $2N^2 = 2(1)^2 = 2$

The number of electron in L shell $2N^2 = 2(2)^2 = 8$

The number of electron in M shell $2N^2 = 2(3)^2 = 18$ Etc, etc

The number of electron in the outer most shell is not distributed $2N^2$ formula. The outer most shell is called valance shell and the electrons in it are called valence electrons.

For example (Cu)

Atomic Number = 29

The number of electron in K shell = $2(1) = 2$

The number of electron in L shell = $2(2)^2 = 8$

The number of electron in M shell = $2(3)^2 = 18$

The number of electron in N shell = 1

3.1.3 Atom energy shells or levels

"The orbit around the nucleus within which the electron rotates is called shells or Energy levels".

Each discrete distance orbit from the nucleus corresponds to a certain energy level. The electron which rotates in the lowest orbit has lowest energy level in the outermost orbit, electrons have higher energy levels. Hence energy levels increase as the distance from the nucleus increases.

There are many shells around the nucleus namely K, L, M, N and so on.

K Shell

The K Shell is the closest shell to the nucleus. It is stable with 2-electrons, corresponding to the structure of Helium whose K Shell is filled with 2-electrons.

L Shell

The *L* Shell is the second closest shell to the nucleus. It is stable with 8 electrons, corresponding to the atomic structure of Neon whose *L* shell is filled with 8-electrons.

M Shell

The *M* Shell is third closest shell to the nucleus. It is stable with 18 electrons corresponding to the atomic structure of Argon (Inert gas) whose *M* shell is filled by 18 electrons.

Shells	Electrons
<i>K</i>	2
<i>L</i>	8
<i>M</i>	18
Total Electrons	28

Other shells which can take maximum electrons is shown by the table.

Shell	Maximum Electrons	Inert Gas
<i>K</i>	2	Helium
<i>L</i>	8	Neon
<i>M</i>	8 (upto Calcium) or 18	Argon
<i>N</i>	8, 18 or 32	Krypton
<i>O</i>	8 or 18	Xenon
<i>P</i>	8 or 18	Radon
<i>Q</i>	8	-

The electron distribution around the nucleus follows $2n^2$ rule, where n is the number of shells lives maximum electrons that can be placed in any shell.

3.1.4 Valence electron

"The electrons in an incomplete outermost orbit are called valence electrons".

Valence electrons are less tightly bound to the atom than those closer to the nucleus. This is because the force of attraction between the positively charged nucleus and the negatively charged electron decreases with increasing distance from the nucleus. Electrons with the highest energy levels exist in the outermost shell of an atom and are relatively loosely bound to the atom. This outermost shell is known as the valence shell and electrons in this shell are called valence electrons.

A completed outermost shell has valence of zero. Copper has valence of 1 because one electron is in outer shell after completing its inner shells. Similarly carbon has a valence of 4 and all the inert gases have zero valence.

3.1.5 Energy Band

When number of atoms is combining then the whole energy levels are divided in sub-energy levels and become overlapped. They make a band, which is called energy band. Remember that the energy of free electron is changing continuously.

In a solid there are three types of energy band.

1. Filter band

As clear from its name it is that type of band, which is near to the nucleus and it is completely full with electron. In that type of band there are no free electrons.

2. Valence band

The last band of the atom is called valence band and the electron of that band is called valence electron. When valence electron gain some energy then they leave that band and cross the energy gap which is also called forbidden energy gap and goes to conduction band then current flow starts from this material. The energy of the valence electron is more as compare to filled band.

3. Conduction band

The conduction band is the band of electrons orbitals that electrons can jump from the valence band when excited and such process is called conduction. The electron of such band is called free electron.

(a) Insulator

Insulator is that material in which current does not flow easily e.g. Wood, paper, plastic, oil, mica etc. The reason for insulation is the wide gap between

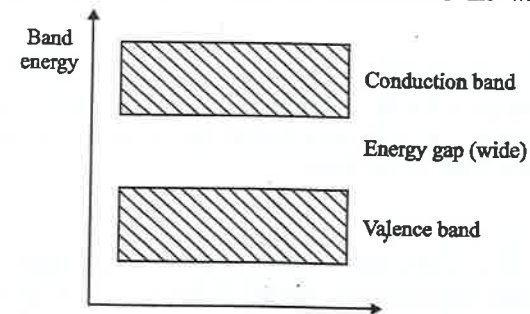

Energy band diagram of insulator

the valence band and conduction band. A large amount of energy is required to shift electrons from the valence band into the conduction band.

(b) Conductor

Conductor is the material in which current flows easily. For example silver, copper and aluminium, etc. The reason for the conduction is the absence of forbidden gap between the conduction band and valence band, so very small amount of energy is required for the flow of electric current. There are many free electrons in the conducting materials.

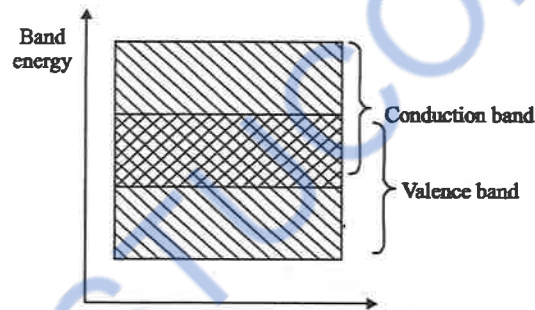

Energy band diagram of conductor

(c) Semiconductor

Semiconductor is the material which has the conduction property in between conductor and insulator. It means semiconductor do not allow the free electron to flow as conductor. In the same way semiconductor doesn't block the current as insulator. For example silicon, boron, carbon etc. The reason for such type of conductor is the small gap between the valence band and conduction band. Semiconductors have comparatively less free electron than the conductor.

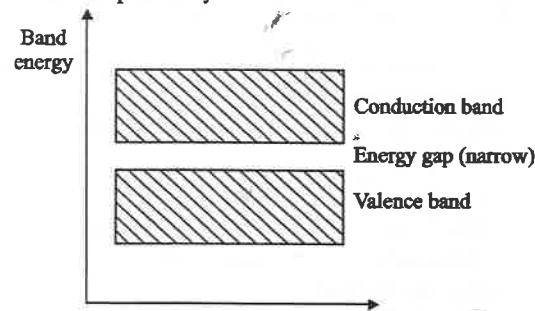

Energy band diagram of semiconductor

3.2 TYPES OF SEMICONDUCTOR

1. Intrinsic semiconductors
2. Extrinsic semiconductors

3.2.1 Intrinsic semiconductor

An intrinsic semiconductor is an undoped semiconductor which is a pure semiconductor without any significant dopant species present. The number of charge carriers is therefore determined by the properties of the material itself instead of the amount of impurities. In intrinsic semiconductors the number of excited electrons and the number of holes are equal: $n = p$.

The electrical conductivity of intrinsic semiconductors can be due to crystallographic defects or electron excitation. In an intrinsic semiconductor the number of electrons in the conduction band is equal to the number of holes in the valence band. An example is $Hg_{0.8}Cd_{0.2}Te$. (Mercury Cadmium Telluride)

An indirect band gap intrinsic semiconductor is one in which the maximum energy of the valence band occurs at a different k (k -spaces wave vector) than the minimum energy of the conduction band. Examples include gallium arsenide.

A silicon crystal is different from an insulator because at any temperature above absolute zero temperature, there is a finite probability that an electron in the lattice will be knocked loose from its position, leaving behind an electron deficiency called a "hole".

If a voltage is applied, then both the electron and the hole can contribute to a small current flow.

The conductivity of a semiconductor can be modeled in terms of the band theory solids. The band model of a semiconductor suggests that at ordinary temperatures there is a finite possibility that electrons can reach the conduction band and contribute to electrical conduction.

The term intrinsic here distinguishes between the properties of pure "intrinsic" silicon and the dramatically different properties of doped n-type or p-type semiconductors.

Electrons and holes

In an intrinsic semiconductor such as silicon at temperatures above absolute zero, there will be some electrons which are excited across the band gap into the conduction band and which can support current flow. When the electron in pure silicon crosses the gap, it leaves behind an electron vacancy or "hole" in the regular silicon lattice. Under the influence of an external voltage, both the electron and the hole can move across the material. In an n-type semiconductor, the dopant contributes extra electrons, dramatically increasing the conductivity. In a p-type

semiconductor, the dopant produces extra vacancies or holes, which likewise increase the conductivity. It is however the behavior of the p-n junction which is the key to the enormous variety of solid-state electronic devices increase the conductivity. It is however the behavior of the p-n junction which is the key to the enormous variety of solid-state electronic devices.

Semiconductor current

The current which will flow in an intrinsic semiconductor consists of both electron and hole current. That is, the electrons which have been freed from their lattice positions into the conduction band can move through the material. In addition, other electrons can hop between lattice positions to fill the vacancies left by the free electrons. This additional mechanism is called hole conduction because it is as if the holes are migrating across the material in the direction opposite to the free electron movement. The current flow in an intrinsic semiconductor is influenced by the density of energy states which in turn influences the electron density in the conduction band. The current is highly temperature dependent.

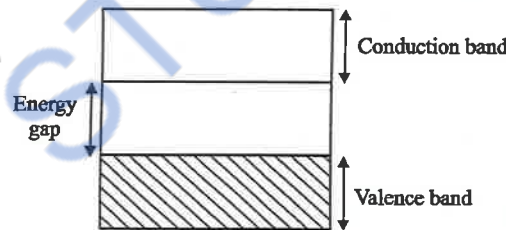

3.2.2 Extrinsic semiconductor

An extrinsic semiconductor is a semiconductor that has been doped, that is a doping agent has been introduced giving it different electrical properties than the intrinsic (pure) semiconductor.

Doping involves adding dopant atoms to an intrinsic semiconductor, which changes the electron and hole carrier concentrations of the semiconductor at thermal equilibrium. Dominant carrier concentrations in an extrinsic semiconductor classify it as either an n-type or p-type semiconductor. The electrical properties of extrinsic semiconductors make them essential components of many electronic devices.

Semiconductor doping

Semiconductor doping is the process that changes an intrinsic semiconductor to an extrinsic semiconductor. During doping, impure atoms are introduced to an intrinsic semiconductor. Impurity atoms are atoms of a different element than the

atoms of the intrinsic semiconductor. Impurity atoms act as either donors or acceptors to the intrinsic semiconductor, changing the electron and hole concentration of the semiconductor. Impurity atoms are classified as donor or acceptor atoms based on the effect they have on the intrinsic semiconductor.

Donor impurity atoms have more valence electrons than the atoms they replace in the intrinsic semiconductor lattice. Donor impurities "donate" their extra valence electrons to a semiconductor's conduction band, providing excess electrons to the intrinsic semiconductor. Excess electrons increase the electron carrier concentration (n_0) of the semiconductor, making it n-type.

Acceptor impurity atoms have fewer valence electrons than the atom they replace in the intrinsic semiconductor. They "accept" electrons from the semiconductor's valence band. This provides excess holes to the intrinsic semiconductor. Excess holes increase the hole carrier concentration (p_0) of the intrinsic semiconductor, creating p-type semiconductor.

Semiconductors and dopant atoms are defined by the column of the periodic in which they fall. The column definition of the semiconductor determines how many valence electrons its atoms have and whether dopant atoms act as the semiconductor's donors or acceptors.

Group IV semiconductors use group V atoms as donors and group III atoms as acceptors.

Group III-V semiconductors, the compound semiconductors, use group VI atoms as donors and group II atoms as acceptors. Group III-V semiconductors can also use group IV atoms as either donors or acceptors. When a group IV atom is replaced by group III element in the semiconductor lattice, then it acts as a donor. Also, when a group IV atom is replaced by group V element, then it act as an acceptor. Group IV atoms can act as both donors and acceptors. Therefore, they are known as amphoteric impurities.

	Intrinsic semiconductor	Donor atoms	Acceptor atoms
Group IV semiconductors	Silicon, Germanium	Phosphorus, Arsenic	Boron, Aluminium
Group III-V semiconductors	Aluminium phosphide, Aluminium arsenide, Gallium arsenide, Gallium nitride	Selenium, Tellurium, Silicon, Germanium	Beryllium, Zinc, Cadmium, Silicon, Germanium.

The two types of intrinsic semiconductor

N-type semiconductors

Extrinsic semiconductors with a larger electron concentration than hole concentration are known as N-type semiconductors. Band structure of an n-type semiconductor is shown in figure 3.6. Dark circles in the conduction band are electrons and light circles in the valence band are holes. The image shows that the electrons are the majority charge carrier.

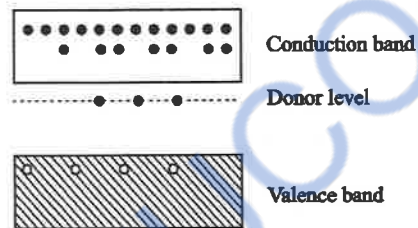

Band diagram of N type semiconductor

The phrase 'n-type' comes from the negative charge of the electron. In n-type semiconductors, electrons are the majority carriers and holes are the minority carriers. N-type semiconductors are created by doping an intrinsic semiconductor with donor impurities (or doping a p-type semiconductor as done in the making of CMOS chips). A common dopant for n-type semiconductors is Phosphorous. In an n-type semiconductor the Fermi energy level is greater than that of the intrinsic semiconductor and lies closer to the conduction band than the valence band.

P-type semiconductors

Extrinsic semiconductors with a large hole concentration than electron concentration are known as P-type semiconductors. Fig. 3.7 shows the band structure of a p-type semiconductor. Dark circles in the conduction band are

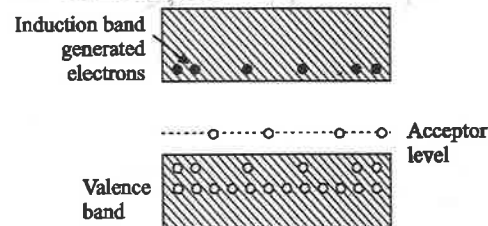

Band diagram of P type semiconductor

electrons and light circles in the valence band are holes. The image shows that the holes are the majority charge carrier

The phrase 'p-type' refers to the positive charge of the hole. In p-type semiconductors, holes are the majority carriers and electrons are the minority carriers. P-type semiconductors are created by doping an intrinsic semiconductor with acceptor impurities (or doping an N-type semiconductor). A common P-type dopant is Boron. P-type semiconductors have Fermi energy levels below the intrinsic Fermi energy level. The Fermi energy level lies closer to the valence band than the conduction band in a p-type semiconductor.

Use of intrinsic semiconductors

Extrinsic semiconductors are components of many common electrical devices. A semiconductor diode (devices that allow current in only one direction) consists of p-type and n-type semiconductors placed in junction with one another. Currently, most semiconductor diodes use doped silicon or germanium.

Transistors (devices that enable current switching) also make use of extrinsic semiconductors. Bipolar junction transistors (BJT) are one type of transistor. The most common BJT's are NPN and PNP type. NPN transistors have two layers of n-type semiconductors sandwiching a p-type semiconductor. PNP transistors have two layers of p-type semiconductors sandwiching an n-type semiconductor.

Field-effect transistors (FET) are another type transistor implementing extrinsic semiconductors. As opposed to BJT's, they are unipolar and considered either N-channel or P-channel. FETs are broken into two families, junction gate FET (JFET) and insulated gate FET (IGFET).

Other devices implementing the extrinsic semiconductor are:

1. Lasers
2. Solar cells
3. Photodetectors
4. Light-emitting diodes
5. Thyristors

3.2.3 Comparison of intrinsic and extrinsic semiconductors

Intrinsic semiconductors	Extrinsic semiconductors
It is pure semiconducting material and no impurity atoms are added to it.	It is prepared by doping a small quantity of impurity atoms to the pure semiconducting material.

Examples: crystalline forms of pure silicon and germanium.	Examples: silicon "Si" and germanium "Ge" crystals with impurity atoms of As, Sb, P etc. or In B, Al etc.
The number of free electrons in the conduction band and the no. of holes in valence band is exactly equal and very small indeed.	The number of free electrons and holes in never equal. There is excess of electrons in n-type semiconductors and excess of holes in p-type semiconductors.
Its electrical conductivity is low.	Its electrical conductivity is high.
Its electrical conductivity is a function of temperature alone.	Its electrical conductivity depends upon the temperature as well as on the quantity of impurity atoms doped the structure.

3.3 PN JUNCTION DIODE

A PN junction diode is formed when n-type and p-type semiconductors are joined together.

Symbol

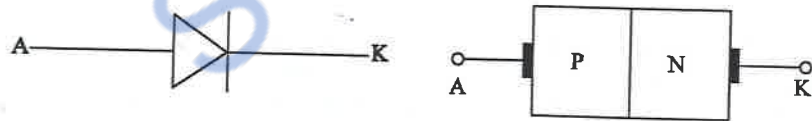

Fig. 3.1

✓ In N-type material,

Majority carriers – electrons

Minority carriers – holes

✓ In P-type material,

Majority carriers – holes

Minority carriers – electrons

- » At the junction there is a tendency for free electrons to diffuse over the P-side and hole to N-side.
- » This process is called diffusion.
- » Electrons combine with holes in P-type material and creates a negatively charged immobilized acceptor ions.

- » Similarly the holes move into N-material and combine with free electrons and creates immobilized donor ions.
- » Thus there is immobilized positive charge on N-side and immobilized negative charge on P-side of the junction. This region is known as Depletion region (or space charge region or transition region).
- » It creates a built-in potential or barrier potential, V_b across the junction.
- » The barrier potential V_b is
0.3 V for Germanium &
0.7 V for Silicon

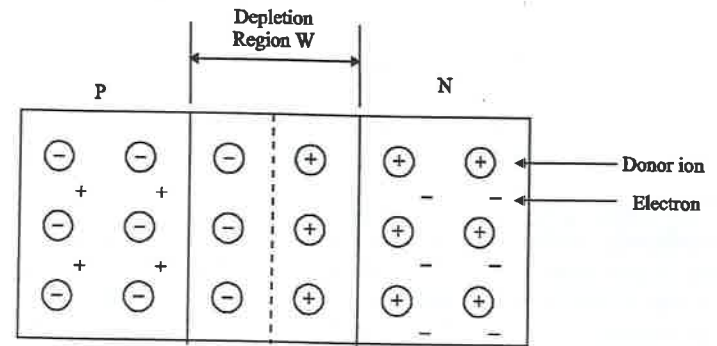

Fig. 3.2

3.3.1 Diode under forward bias condition

This is done by connecting positive terminal of battery to P-type and its negative terminal to N-type as in figure.

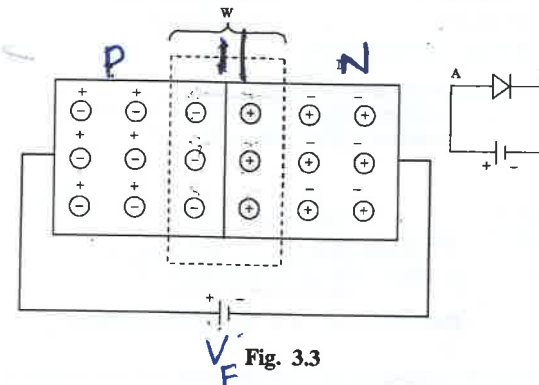

Fig. 3.3

(i) Operation

- » Under forward bias, the applied positive voltage repels the holes in P-type and holes move towards the junction.
- » Similarly, the applied negative voltage repels the electrons in N-type region and electrons move towards the junction.
- » Hence the barrier height reduces with reduction in width of depletion region.
- » Therefore the holes from P-type move to N-type and electrons from N-type move towards P-type and due to this there is current flow and it is called as forward current, I_f

(ii) $V-I$ Characteristics under forward bias

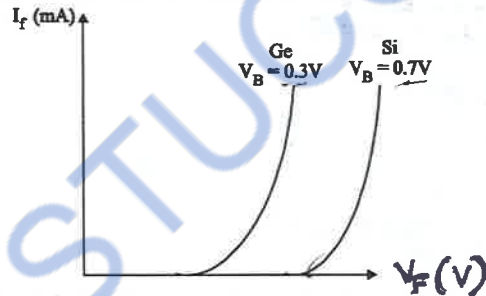

Fig. 3.4 $V-I$ Characteristics under forward bias

For $V_f > V_B$, the potential barrier disappears at the junction and large current, I_f flows.

3.3.2 Diode under reverse bias condition

Reverse bias is obtained by connecting positive terminal of the battery to N-type and negative terminal to the P-type.

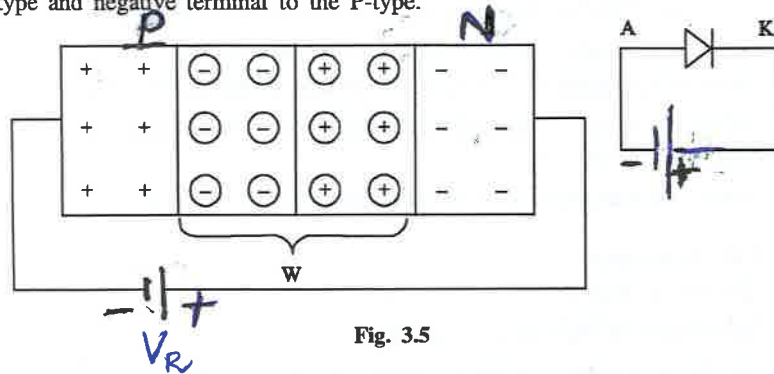

Fig. 3.5

(i) Operation

- » Under reverse bias, the majority electrons are attracted by positive terminal and majority holes are attracted by negative terminal of battery.
- » As a result, the depletion region is widened and the barrier potential rises.
- » The majority carriers cannot overcome this barrier energy and their flow is reduced to zero.
- » The minority carriers however will cross the junction and contributes reverse current.

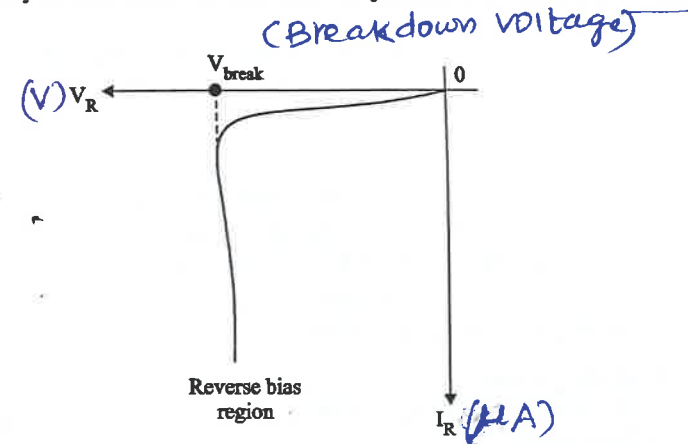

Fig. 3.6 $V-I$ Characteristics under reverse bias

For large applied reverse bias voltage, electrons move towards positive terminal of battery since a large number of electrons are formed, it is called avalanche of free electrons. This leads to breakdown of junction leading to large reverse currents. The reverse voltage at which the junction breakdown occurs is known as breakdown voltage.

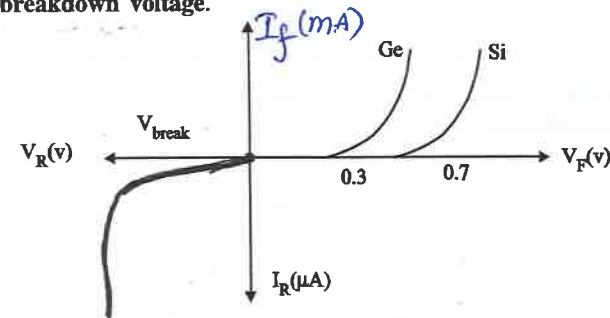

Fig. 3.7

3.3.3 Diode applications

1. As rectifiers or power diodes
2. As signal diodes
3. As zener diode in voltage regulation circuits.
4. As varactor diode in radio and TV receiver.
5. As a switch in logic circuits.

Avalanche effect

In PN-junction under reverse bias the avalanche breakdown occurs. This leads to breakdown to junction leading to large reverse current. Here the multiplication of number of free electrons causes the reverse current to increase rapidly.

Zener effect

- » Zener breakdown is different from avalanche breakdown.
- » Zener breakdown occurs when the electric field in the depletion layer increases and it breaks covalent bond and generates electron hole pair
- » In this a large number of carriers are generated.
- » This process is quantum tunneling.

3.4 Zener diode

A zener diode is also called as voltage reference, voltage regulator or breakdown diode.

Symbol

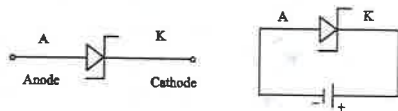

Fig. 3.8 Symbol

- » Zener diode is operated in the reverse breakdown region.
- » The breakdown voltage of a zener diode is set by controlling the doping level during manufacture.

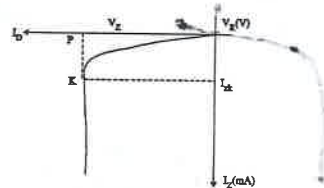

Fig. 3.9 Reverse characteristic of a zener diode

UNIT 3

3.4.1 Reverse characteristic of zener diode

- » Zener diode is operated in reverse bias only
- » Zener diode is operated only in the reverse-bias region.
- » From fig. the reverse voltage (V_R) is increased, the reverse current (I_R) remains negligibly small upto the 'knee' of the curve 'p'.
- » At this point, the effect of breakdown process begins.
- » From the bottom of knee, the breakdown voltage, V_z remains constant. This ability of a diode is called regulating ability.

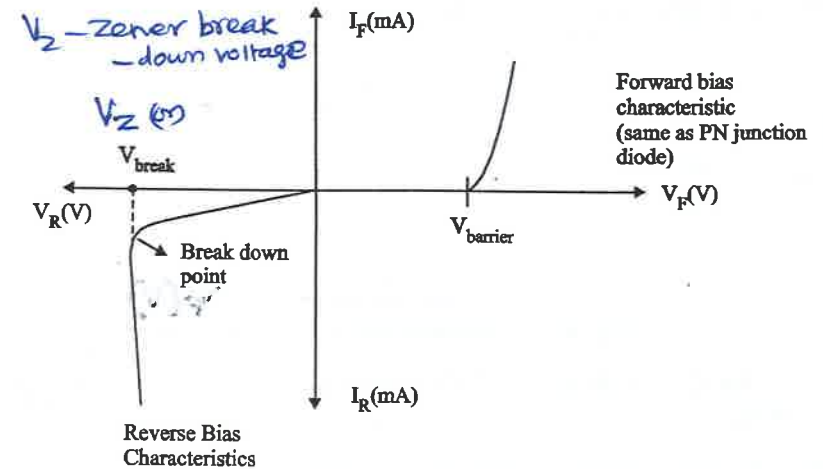

Fig. 3.10 V-I Characteristics of Zener diode

Forward bias characteristic (same as PN junction diode)

- » There is a minimum value of zener current called breakover current ($I_{z\ min}$) which must be maintained in order to keep the diode in breakdown or regulation region.
- » When the current is reduced below knee, the voltage changes drastically and regulation is lost.
- » Above the maximum value of zener current $I_{z\ (max)}$ the diode may be damaged.

3.4.2 Applications

- » As voltage regulators
- » As clippers in wave-shaping circuits
- » As fixed reference voltage in power supplies and transistor biasing.

UNIT 3

3.5 TRANSISTOR

- » A bipolar junction transistor is a three-layer two junction and three-terminal semiconductor device.
- » Its operation depend: on the interaction of majority and minority carriers. Therefore it is named as bipolar device.

(TRANSFER + RESISTOR \Rightarrow Transistor)

- » Transistor means, signals are transferred from low resistance circuit (input) into high resistance (output) circuit.

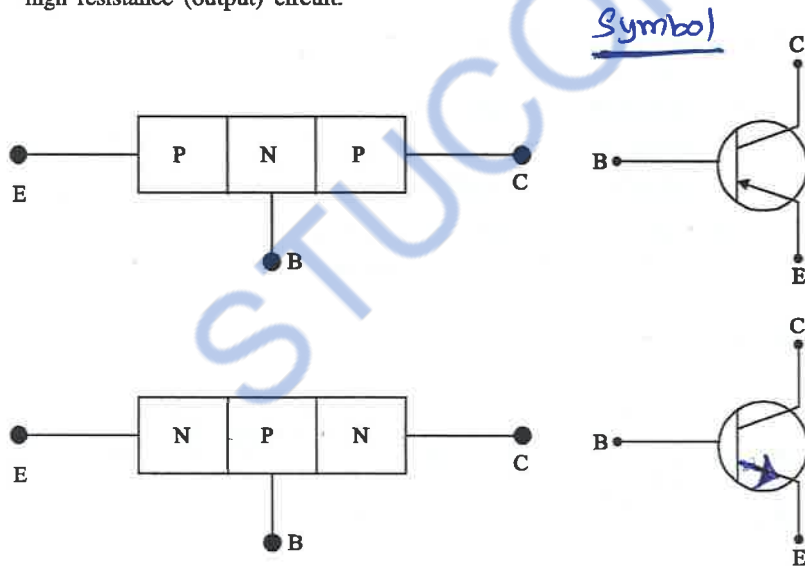

Fig. 3.11

Emitter

It is more heavily doped than any of other regions because its main function is to supply majority charge carriers to the base.

- » The current through the emitter is emitter current. It is denoted as I_E .

Base

- » Base is the middle section of the transistor.
- » It separates the emitter and collector.
- » It is very lightly doped. It is very thin as compared to either Emitter (or) collector.

- » The current flows through the base section is base current, and its denoted as " I_B ".

Collector

- » The main function of the collector is to collect the majority charge carriers coming from the Emitter and passing through the base.
- » It is a moderately doped. The current flows through collector is collector current. It is denoted as I_C .

Types

PNP and NPN Transistors

- » Emitter section is always to provide charge carriers, therefore, it is always forward biased.
- » First letter of transistor type indicates the polarity of the emitter voltage with respect to base.
- » The main function of collector is to collect (or) attract those carriers through the base, hence it is always reverse biased.
- » Second letter of transistor type indicates the polarity of collector voltage with respect to the base.

3.5.1 Working of PNP - transistor

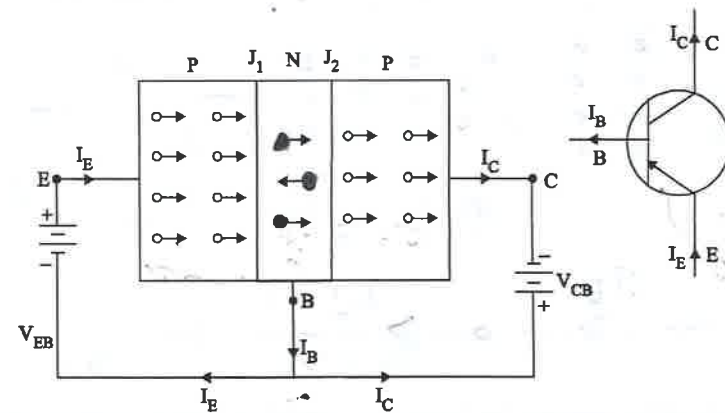

Fig. 3.12

- » The above diagram shows the connection of PNP-transistor.
- » Here, the emitter-base junction is forward biased, and collector - base junction is reverse biased.

- » The holes in the emitter are repelled by the positive terminal of battery.
- » Then the potential barrier at emitter - base junction is reduced as a result of this depletion region dis-appears, hence holes cross the junction and enter into N-region (base).
- » This constitutes the emitter current I_E . Because the base region is thin and lightly doped. Majority of the holes (about 97.5%) are able to drift across the base without meeting electrons to combine with only 2.5% of the holes recombine with the free electrons (or) N-region.
- » This constitutes the base current I_B , which is very small.
- » The holes which after crossing the N-P collector junction enter the collector region.

They are swept by the negative collector voltage V_{CB} . This constitutes the collector current I_C .

$$I_C = I_E - I_B$$

$$I_E = I_B + I_C$$

3.5.2 Working of N-P-N transistors

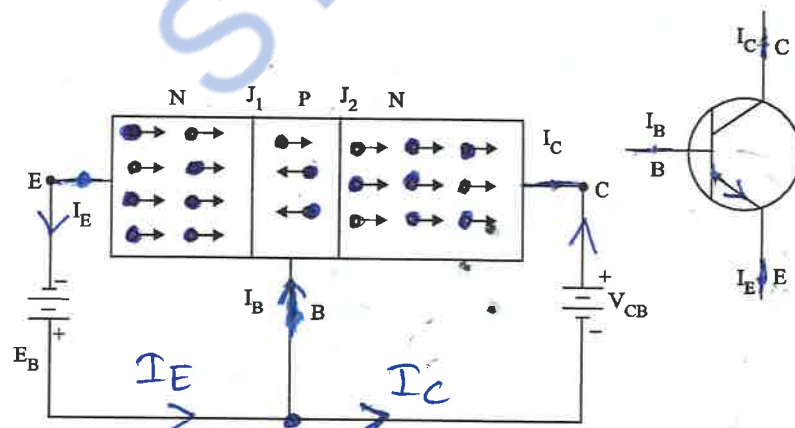

Fig. 3.13

- » In this circuit diagram, the Emitter-base junction is forward biased (i/e negative polarity of the battery (V_{EB}) is connected to N-type Emitter terminal.
- » Similarly, the collector - base junction (J_2) is reverse biased by connecting +ve terminal of battery with Negative (N-type) material.

- » The electrons in the emitter region are repelled by the negative battery terminal towards the emitter junction.
- » The electrons ^{cross} into the p-type base region because potential barrier is reduced due to forward bias, and base region is very thin and highly doped.
- » Most of the electrons (about 97.5%) cross-over to the collector junction and enter the collector region, where they are readily swept up by the positive collector voltage V_{CB} . Only 2.5% of the emitter electrons combine with the holes in the base and are lost as charge carriers.

3.5.3 Transistor - Configurations

There are 3-Configurations

1. Common-Base Configuration
2. Common-Emitter Configuration
3. Common-Collector Configuration

1. COMMON-BASE CONFIGURATION

- » In this configuration, base terminal acts as a common - terminal for input and output.

Diagram

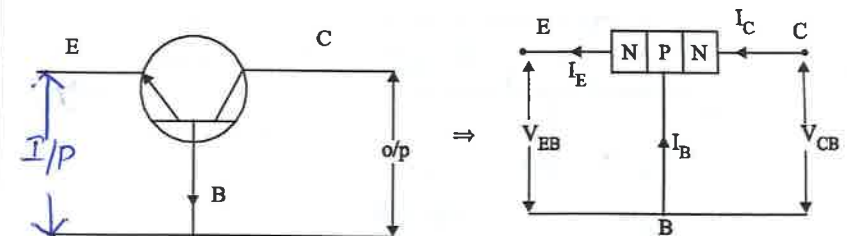

Fig.

- » In this configuration, input is applied between emitter and base while output is taken from collector and base. Here, base acts as a common input and output.

(i) Input characteristics

- » This diagram, shows, how the input (I_E) emitter current varies with input voltage V_{EB} , when output voltage ' V_{CB} ' is held constant.
- » To determine the input characteristics initially, the output voltage V_{CB} is set as zero, then the input voltage V_{EB} is increased.

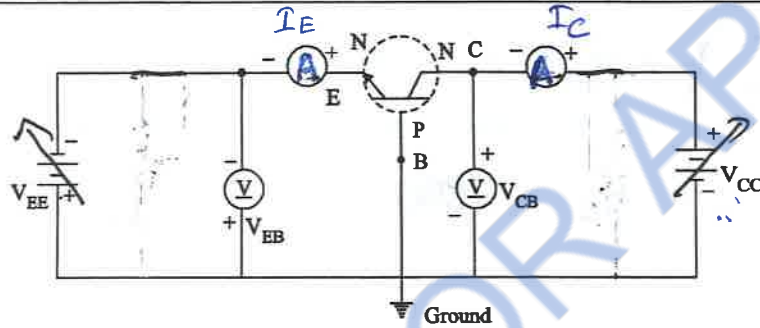

Fig. 3.14

- » The input characteristics drawn between emitter current I_E and emitter-base voltage V_{EB} .
- » The emitter current (I_E) is taken along y-axis and V_{EB} along x-axis.
- » From the above graph, the emitter current (I_E) increases rapidly with small increase in emitter base voltage.

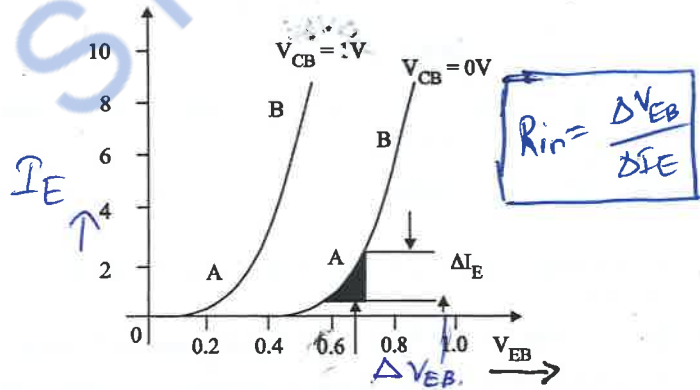

Fig. 3.15

- » This indicates that the input resistance is very small.
- » And also, the emitter current is almost independent of collector-base voltage.
- » This leads to the conclusion that, emitter current I_E and hence collector current (I_C) is almost independent of collector-base voltage (V_{CB}).
- » This input characteristics used to find the input resistance of the transistor.

Input resistance $(R_{in}) = \frac{\Delta V_{EB}}{\Delta I_E}$ at constant V_{CB}

where, $\Delta V_{EB} \Rightarrow$ Change in Emitter-base junction voltage

$\Delta I_E \Rightarrow$ Change in emitter-current

(ii) Output characteristics

To determine the output characteristics, the emitter current I_E is kept constant, at a suitable value by adjusting the emitter-base voltage V_{EB} and varying R_2 and output voltage current (I_C) is measured.

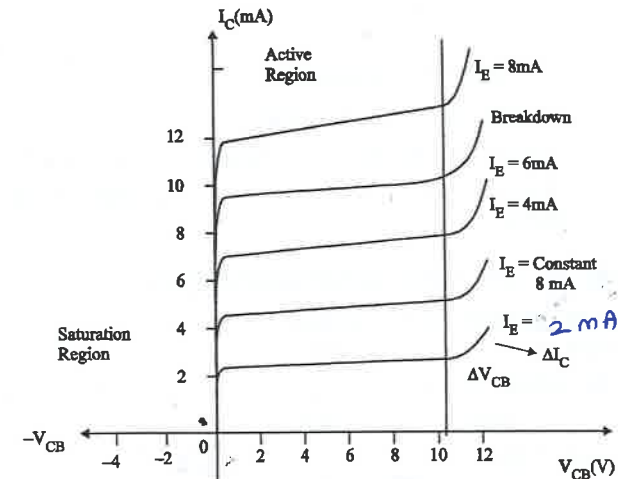

Fig. 3.16

- » The collector-base voltage (V_{CB}) is increased from zero in a number of steps, and the corresponding collector current (I_C) is noted.
- » This output characteristics is drawn between collector current (I_C) and collector base voltage (V_{CB}), at constant emitter current (I_E).

Output resistance $R_{out} = \frac{\Delta V_{CB}}{\Delta I_C}$

$\alpha \rightarrow$ current gain in CB

» This characteristic is used to find amplification factor

$\alpha = \frac{\Delta I_C}{\Delta I_E}$

(or) $\alpha \rightarrow$ current amplification factor

configuration

Saturation region

It is the region left to the vertical line. In this region collector-base voltage V_{CB} is negative. i.e, the collector base junction is also forward biased and a small change in V_{CB} results in larger variation in collector current.

Active region

- » It is the region, between the vertical line to horizontal axis.
- » In this region, the collector current is almost constant and is equal to the emitter current.
- » In this region, the emitter base junction is forward biased and collector-base junction is reverse biased.

Cut-off region

- » It is the region along the horizontal axis.
- » In this region, both junctions are reverse biased.
- » Due to this, there is no current flow in collector terminal due to majority carriers.
- » But due to minority carriers current will flow. This current is known as reverse saturation current.

2. COMMON EMITTER CONFIGURATION

- » In this configuration, input is applied between base and emitter and output is taken from the collector and emitter.
- » Here, the emitter terminal is common to both input and output. Hence it is called common-emitter configuration.

(i) Input characteristics:

Fig. 3.17

The above diagram shows the circuit diagram for common-emitter configuration.

- » At constant V_{CE} , the input current I_B varies with the variation of V_{BE} .

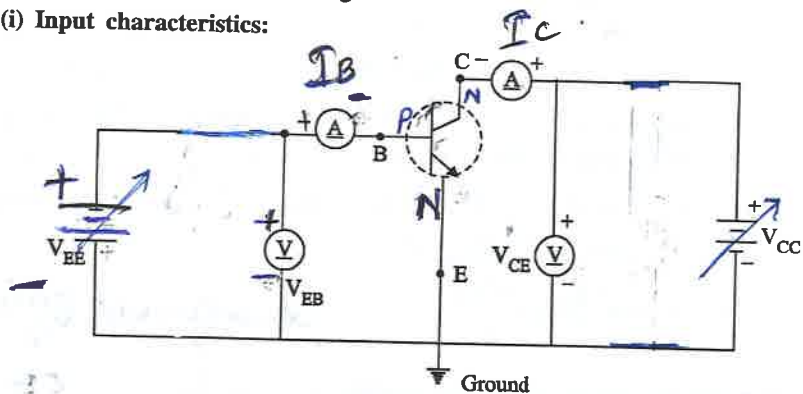
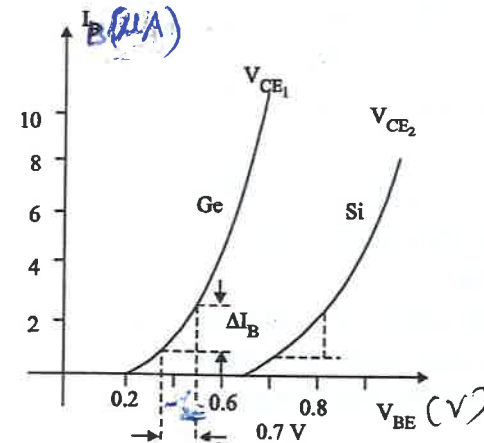

Fig. 3.18

- » If the input voltage (V_{BE}) is less than threshold (or) knee voltage below which the base current is very small.
- » The value of knee voltage is 0.3 V for germanium and 0.7 V for silicon transistor.
- » Knee voltage means, the voltage at which conduction starts i.e input current increases.
- » This characteristics is similar to the forward biased P-N junction diode curve.
- » As compared to CB configuration, I_B increases less rapidly with V_{BE} .
- » Therefore, input resistance of a CE configuration is higher than that of CB configuration.
- » Input resistance

$$R_{in} = \frac{\Delta V_{BE}}{\Delta I_B}$$

at constant V_{CE}

(ii) Output characteristics

It is a curve between collector current and collector-emitter voltage as constant base current (I_B).

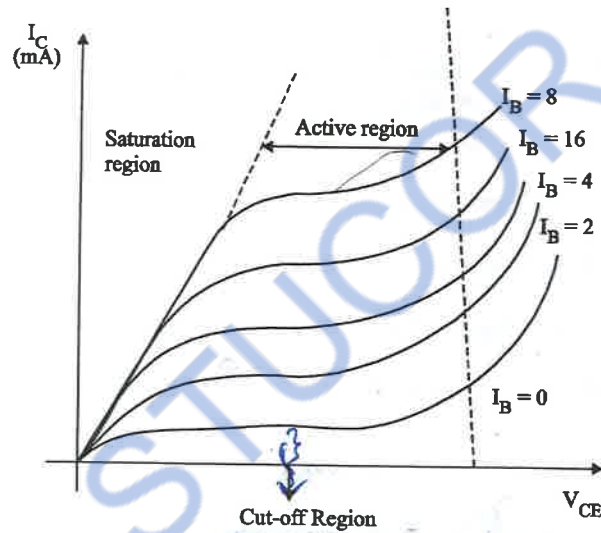

Fig. 3.19

- » From the graph, V_{CE} increases from zero to one volt, current I_C rapidly increases.
- » This region is called saturation region.

$$\text{We know that } \frac{1}{1-\alpha} = \beta + 1 = \gamma$$

$$\text{Therefore } I_B = I_B (\beta + 1) + I_{CBO} (\beta + 1)$$

- » It may be noted that, if V_{CE} is increased continuously, then depletion region in CB junction increased, it increases I_C and operates the transistor in active region.
- » Further increase in V_{CE} causes avalanche breakdown in CB junction as a result of this, enormous I_C will flow and the transistor into breakdown region.
- » This characteristics can be used to find current gain β . It is defined as the ratio of change in output current (ΔI_C) to the change in input current (ΔI_B).

$\beta \rightarrow$ current gain
in CE configuration $\beta = \frac{\Delta I_C}{\Delta I_B}$

- » Output resistance $R_{out} = \frac{\Delta V_{CE}}{\Delta I_C}$ at constant I_B

3. COMMON COLLECTOR CONFIGURATION

In this configuration, collector terminal is common to input and output.

Circuit diagram

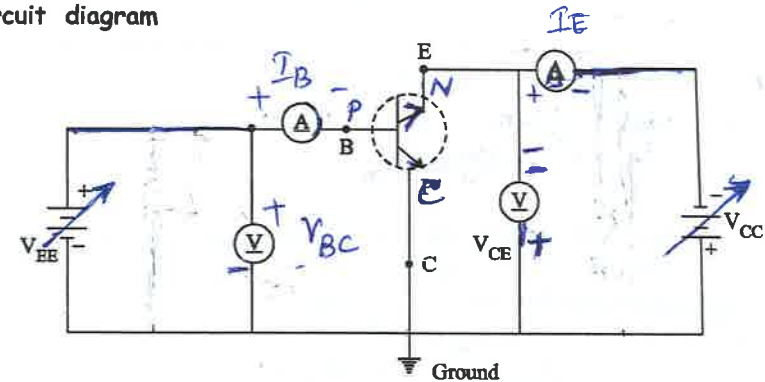
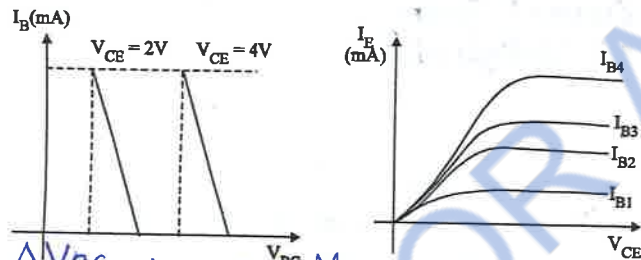

Fig. 3.20

- » The above diagram shows the circuit diagram of common collector configuration.
- » To determine the output characteristic, the base current I_B is kept constant. At a suitable value by adjusting the base-collector voltage and varying R_L and the output current (Emitter current I_E) is measured.
- » Since I_C is approximately equal to I_E , thus common collector characteristics is identical to CE configuration.

$$R_{out} = \frac{\Delta V_{CE}}{\Delta I_E} \text{ at constant } I_B$$

(ii) Input characteristics



$$R_{in} = \frac{\Delta V_{BE}}{\Delta I_B} \text{ at constant } V_{CE}$$

» This characteristics may be used to find current amplification factor (γ).

$\gamma \rightarrow$ Gamma
 $\gamma \rightarrow$ current gain
 in CC configuration
 at constant V_{CE}

$$\gamma = \frac{\Delta I_E}{\Delta I_B}$$

3.5.4. Comparison of CB, CE and CC Configuration

No.	Property	CB	CE	CC
1.	Input resistance	Low $R_{in} = \frac{\Delta V_{EB}}{\Delta I_E}$ (about 100 Ω)	Moderate $R_{in} = \frac{\Delta V_{BE}}{\Delta I_B}$ (about 750 Ω)	High $R_{in} = \frac{\Delta V_{BC}}{\Delta I_B}$ (about 750)
2.	Output resistance	High $R_{out} = \frac{\Delta V_{CB}}{\Delta I_C}$ (about 450 Ω)	Moderate $R_{out} = \frac{\Delta V_{CE}}{\Delta I_C}$ (about 45 Ω)	Low $R_{out} = \frac{\Delta V_{CE}}{\Delta I_E}$ (about 25 Ω)
3.	Current gain	1	High (100)	High (100)
4.	Voltage gain	About 150	About 150	Less than unity
5.	Phase shift between input and output voltage	0 (or) 360°	180°	0 or 360°
6.	Leakage current	Very small	Very large	Very large
7.	Applications	Used in high frequency applications	Used in audio frequency applications	For impedance matching

No.	Property	CB	CE	CC
8.	Current Amplification factor	$\alpha = \frac{\Delta I_C}{\Delta I_E}$	$\beta = \frac{\Delta I_C}{\Delta I_B}$	$\gamma = \frac{\Delta I_E}{\Delta I_B}$

In a transistor amplifier with AC input signal, the ratio of change in output current to the change in input current is known as **current amplification factor**.

In CB configuration,

$$\text{The current amplification factor } \alpha = \frac{\Delta I_C}{\Delta I_E} \quad \dots(1)$$

In CE configuration,

$$\text{The current amplification factor } \beta = \frac{\Delta I_C}{\Delta I_B} \quad \dots(2)$$

» After this, collector current I_C becomes almost constant, and independent with V_{CE} .

» This value of V_{CE} upto which collector current I_C changes is called the "knee voltage".

» When $I_B = 0$, a small amount of collector current flows. It is called reverse saturation current (I_{CEO}). Since the main collector current is zero, the transistor is said to be cut-off region.

3.6 FIELD EFFECT TRANSISTOR

» FET is a device in which the flow of current through the conducting region is controlled by electric field.

» Hence the name is called as field Effect transistor (FET).

» Current conduction is only by majority carriers

FET is said to be unipolar device.

» Based on construction, FET is classified into two types.

(i) Junction Field Transistor (JFET)

(ii) Metal Oxide Semiconductor Field Effect Transistor (MOSFET)

3.6.1 JFET

Depending on the majority carriers, JFET is classified into two types.

(i) N-Channel JFET

(ii) P-Channel JFET

N-Channel JFET

» majority carriers are electrons

P-Channel JFET

» majority carriers are holes

N-Channel JFET

It consists of N-type silicon base. The small piece of P-type materials are attached to its side forming P-N junction.

Sources (S)

Through which the majority carriers enters into N-Channel bar.

Drain (D)

Through which the majority carriers leaving from N-Channel bar.

Gate (G)

Heavily doped P-type silicon is diffused on both sides of N-type bar. Both junctions are connected to form gate.

N-Channel

The region between two depletion region is said to be N-channel.

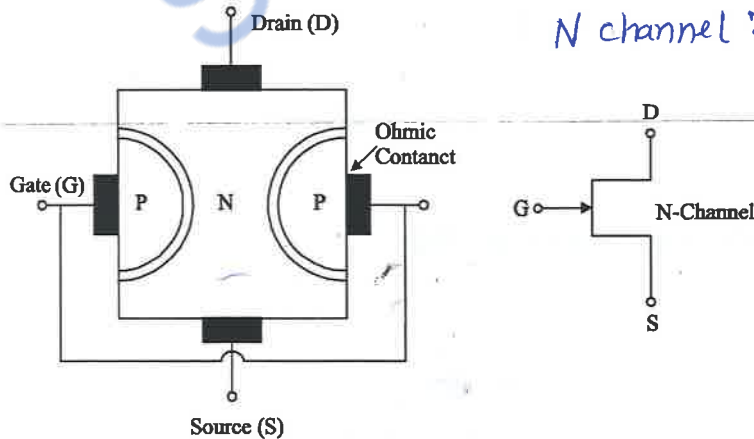

Fig. 3.22

P-Channel

The region between two depletion region is said to be P-Channel

N channel JFET

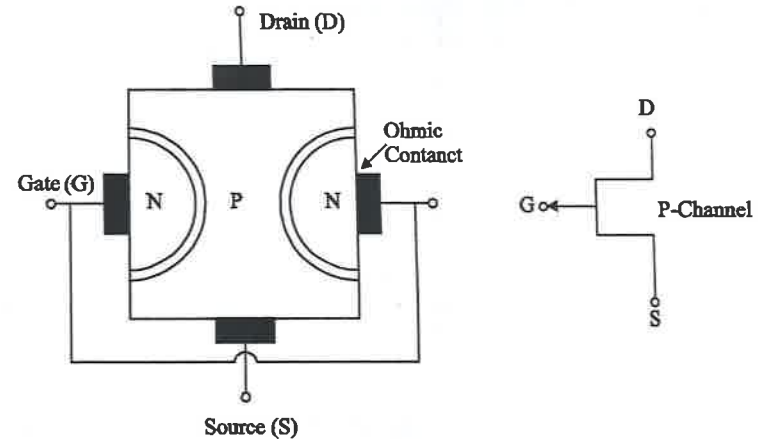

Fig. 3.23 P-Channel JFET

(i) Operation of N-Channel JFET

(i) When $V_{gs} = 0$ and $V_{DS} = 0$

When no voltage is applied between drain and source and gate to source the thickness of depletion region is uniform as shown in diagram.

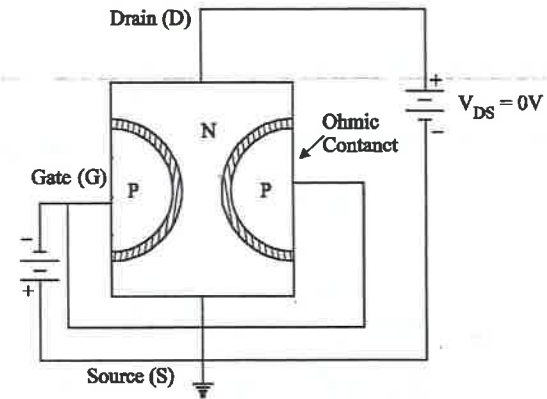

Fig. 3.24

(ii) When $V_{DS} = 0V$ and V_{GS} is decreased from zero

In this case, PN junctions are reverse biased. Hence thickness of the depletion region is increased as V_{gs} is further decreased from zero, the reverse

biased voltage increases. Hence thickness of the depletion regions are also increased until the 2 depletion regions contact with each other. This condition is said to be cut-off.

Cut-off voltage [$V_{gs(OFF)}$]

The V_{gs} value at which the I_D current cut-off in JFET is called cut-off voltage (or) $V_{gs(OFF)}$

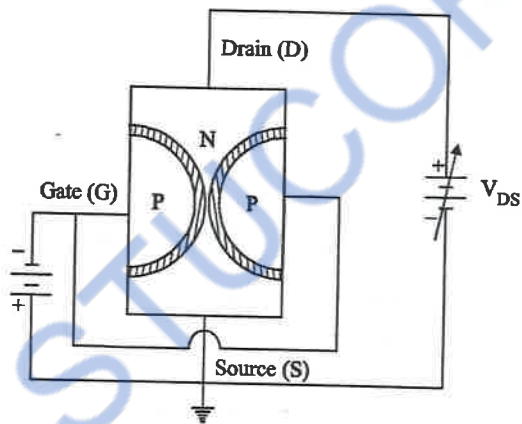

(iii) When $V_{gs} = 0$ and V_{DS} is increased from 0

As shown in diagram drain is positive with respect to source with $V_{gs} = 0V$.

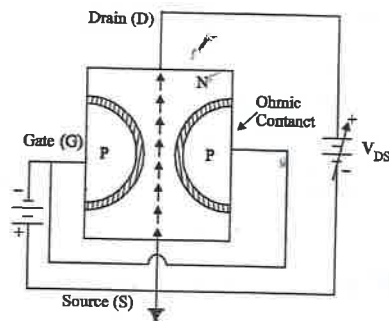

Now the majority carriers (electrons) flow through the N-channel from source to drain. I_D (Drain current) flow from drain to source.

From fig. as V_{DS} is further increased, the thickness of depletion region also increases. The channel is wedge shaped as shown in diagram. Hence, upper region is more reverse biased than lower region.

PINCH - OFF Voltage (V_p)

At the certain value of V_{DS} the cross sectioned area (channel path) of JFET becomes minimum.

At this voltage the channel is said to be pinch off and the voltage (V_p) is called pinch-off voltage.

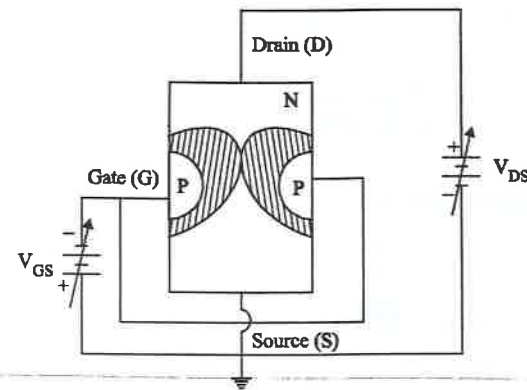

(ii) Characteristics of JFET

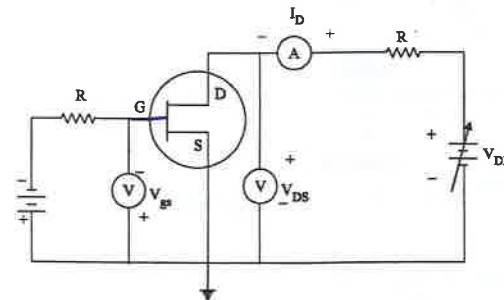

Fig. 3.25

Two types

- (i) Drain characteristics
- (ii) Transfer characteristics

Drain characteristics

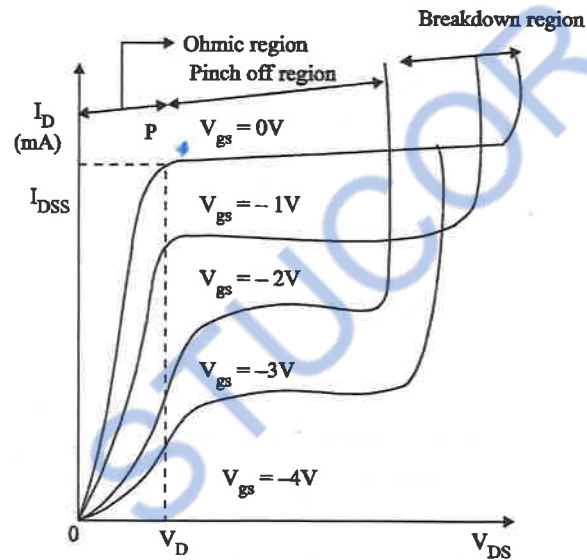

Fig. 3.26

As in graph, V_{DS} is increased from zero, I_D increases along V_p and the rate of increase of I_D with V_{DS} decreases. The region from $V_{DS}=0V$ to $V_{DS}=V_p$ is called V_{DS} ohmic region.

In Ohmic region, the drain to source resistance $\frac{\Delta V_{DS}}{\Delta I_D}$ is related to gate voltage V_{gs} .

When $V_{DS}=V_p$, I_D becomes maximum. When V_{DS} is increased beyond V_p , the length of the pinch-off (or) saturation region increases.

Hence, there is no further increase of I_D . At a certain voltage corresponding to the point 'B', I_D suddenly increases.

Thus effect is due to the Avalanche multiplication of electrons caused by breaking of covalent bonds.

The drain voltage (V_{DS}) at which the breakdown occurs is denoted by BV_{DGO} .

When $V_{gs}=0V$, variation of I_D with V_{DS} is shown as curve $OABC$.

When V_{gs} is negative and V_{DS} is increased when gate is maintained at negative voltage ($V_{gs}=-1V, V_{gs}=-2V, \dots$) The reverse voltage across the junction is further increased. Hence, I_D current decreases then above the pinch off voltage

Transfer characteristics

For the transfer characteristics V_{DS} is kept constant at a suitable value greater than the pinch off voltage (V_p).

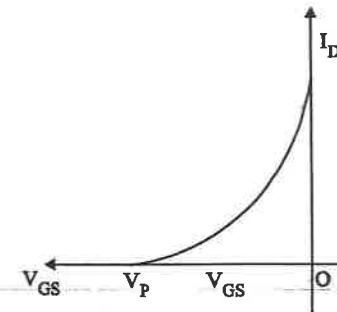

Fig. 3.27

The gate voltage V_{GS} is decreased from zero till I_D is reduced to zero. The transfer characteristics I_D Vs V_{GS} is shown in graph.

(iii) Applications of JFET

1. Used as an electronic switch
2. Used as an amplifier
3. Used as chopper
4. Used as buffer
5. Used in digital circuit

3.6.2 Metal oxide semiconductor field effect transistor (MOSFET)

» MOSFET are electronic devices used to switch or amplify voltage in circuits.

» It is a current controlled device.

» It has 4 terminal.

1. Source 2. Gate 3. Drain 4. Body

Types

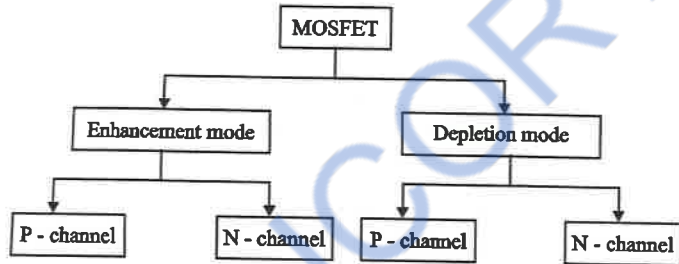

Enhancement MOSFET

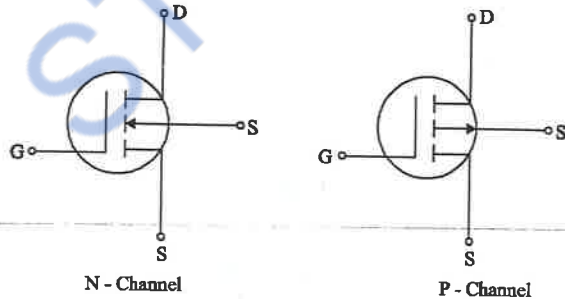

Fig. 3.28

Depletion MOSFET

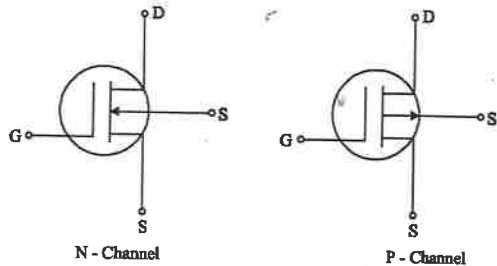

Fig. 3.29

UNIT 3

(i) Enhancement MOSFET

Construction

The construction of a N-channel Enhancement MOSFET is shown in fig. 3.30

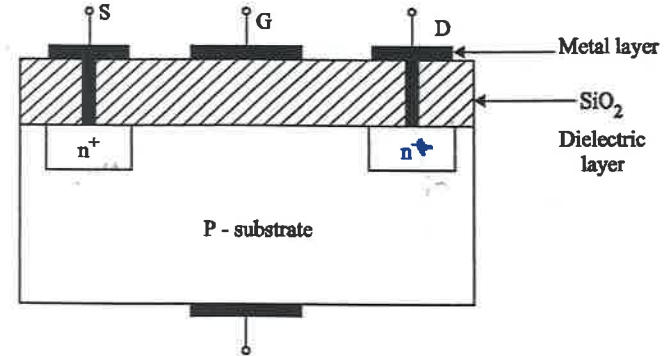

Fig. 3.30

The construction of a N-channel Enhancement MOSFT is shown in fig.

As there is no channel in E-MOSFET the symbol by the break line in the symbols.

Two heavily doped N^+ region are diffused in lightly doped substrate of p -type silicon substrate $D N^+$ region is called the source (S) and the other is called drain (D).

A thin insulating layer of SiO_2 is grown over the surface of the structure and holes are cut into the oxide layer, allowing contact with source and drain.

Then a thin layer of metal aluminium is formed over the layer of SiO_2 . This metal layer covers the entire channel region and it forms the gate (G).

Operation

The substrate and source are grounded and positive voltage is applied at the gate.

The positive charge on gate induces an equal negative charge on the substrate side between source and drain region.

The path is created between source and drain regions. The negative charge of electrons which are minority carriers in the P -type substrate form an inversion layer.

UNIT 3

The positive voltage on the gate increases and the induced negative charge in the semiconductor increases.

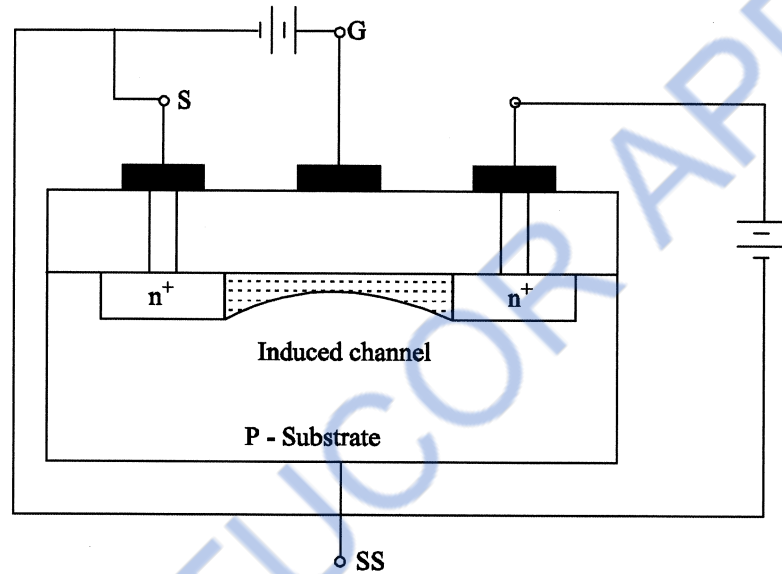

Fig. 3.31

Hence, the conductivity increases and current flows from source to drain through the induced channel.

The drain current is enhanced by the positive gate voltage as in graphs.

Drain transfer characteristics

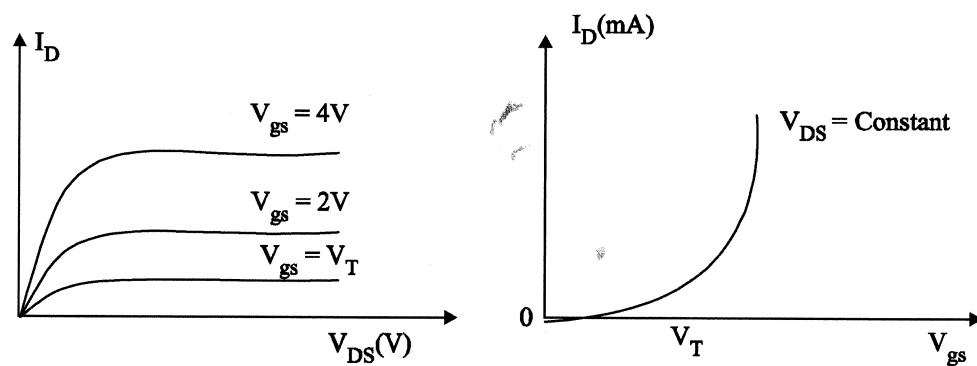

Fig. 3.32

(ii) Depletion MOSFET

Construction

The construction of *N*-channel depletion MOSFET is shown in fig. 3.33.

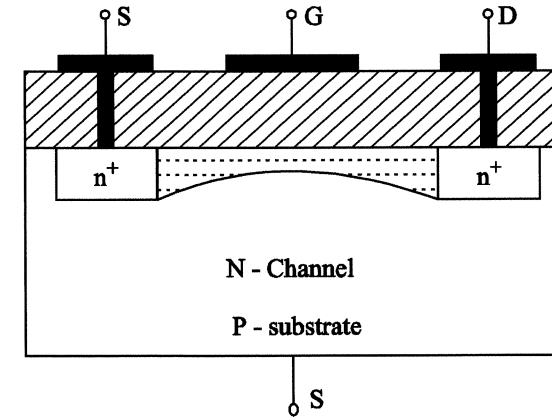

Fig. 3.33

When *N*-channel is diffused between the source and drain to the basic structure of depletion MOSFET.

Operation

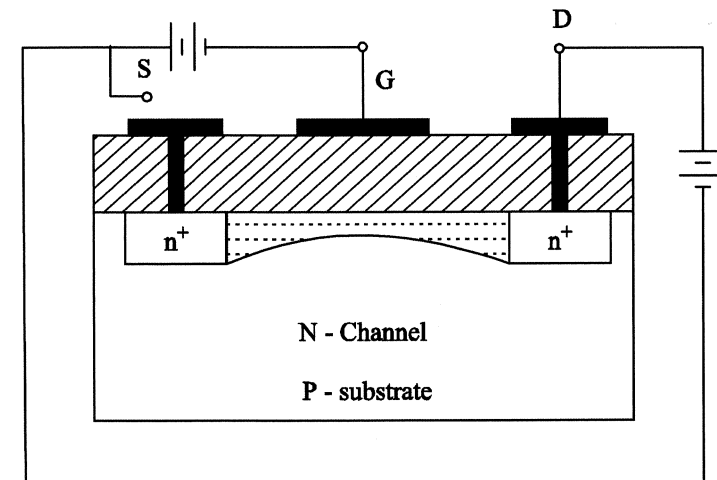

Fig. 3.34

When $V_{GS} = 0$

The drain is positive w.r.t source the current flow (I_D) from source to drain through *N*-channel.

When $V_{GS} = -1V, -2V, \dots$

The drain to source current flow is reduced, since the N -channel width is reduced

When $V_{GS} = V_{GS(OFF)}$

Between source to drain the N -channel width becomes zero. So no I_D flows.

When $V_{GS} = +1V, +2V, \dots$

When V_{GS} is positive voltage, this induces the increase the N -channel width between source to drain. So current flows through N -channel is also more. This is called Enhancement mode.

Drain transfer characteristics

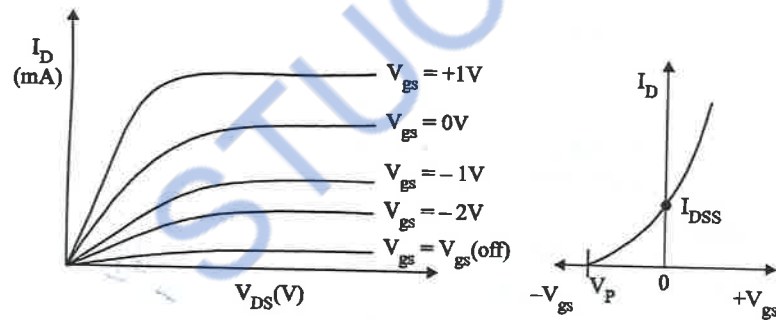

Fig. 3.35

1. Used as amplifier in radio frequency (RF) applications.
2. Used as passive element like resistor (R), Capacitor (C) Inductor (L)
3. Used as power regulators
4. Used as high speed switch
5. Used as Electronic DC relay

3.7 SILICON CONTROLLED RECTIFIER (SCR)

- » A silicon controlled rectifier is a four layer solid state current controlling device.
- » It is also called as semiconductor controlled rectifier.
- » SCRs are available from few voltages to several KV and few amperes to several KV
- » It is a unidirectional device

- » It is a bipolar device (both electrons and holes are charge carriers)

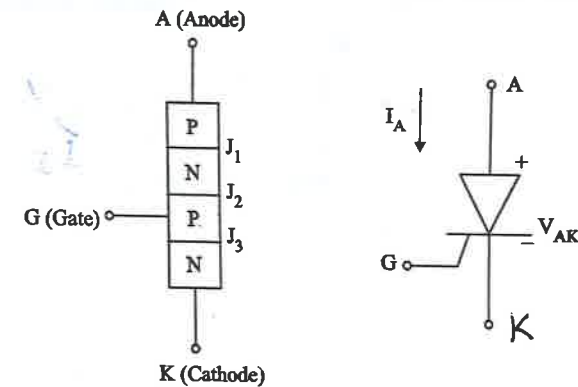

Fig. 3.36

- » It is a 4 layer PNPN switching device with alternate layer of P and N semiconductor materials.
- » It converts the AC signal to DC signal in controlled manner.
- » For current conduction, J_1, J_2, J_3 must be forward biased.

(i) Working modes

1. Forward blocking mode (FBM)
2. Forward conduction mode (FCM)
3. Reverse blocking mode (RBM)

1. Forward blocking mode

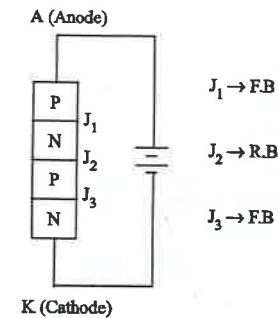

Fig. 3.37

- » J_1 and J_3 are forward biased, whereas J_2 is reverse biased.
- » So there is only small current flowing through SCR. This is called as Forward blocking mode.

2. Forward conduction mode

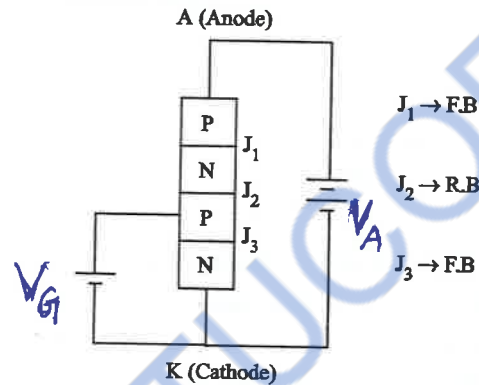

Fig. 3.38

In this, the three junctions are forward biased. Hence the forward voltage drops and current starts to increase linearly.

3. Reverse blocking mode

In this, J_1 and J_3 are reverse biased. When V_R voltage is increase there is small amount of current flow. At one level, there is junctional breakdown and the current starts to increase rapidly.

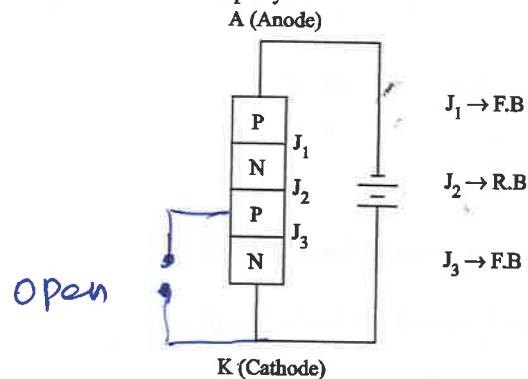

Fig. 3.39

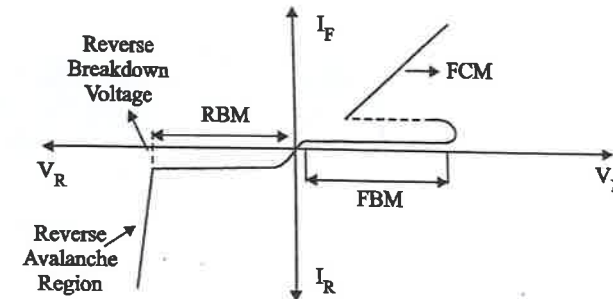

Fig. 3.40

The voltage at which SCR is switched ON can be controlled by ~~varying~~ ^{Varying} the gate current.

(ii) Applications of SCR

1. Used in AC voltage stabilizers.
2. Used as switch.
3. Used as choppers.
4. Used in inverter circuit.
5. Used in battery charger.
6. Used for speed controlled DC motor.

3.8 INSULATED GATE BIPOLAR TRANSISTOR (IGBT)

- » IGBT is a multi-layer semiconductor structure with alternate P-type and n-type doping.
- » IGBT is combination of both power MOSFET and power BJT.
- » IGBT is also known as Metal Oxide Insulated Gate Transistor (MOSIGT), Conductively - Modulated Field Effect Transistor (COMFET) Gain Modulated FET (GMFET).

The N^+ layer substrate in drain is substituted in the IGBT by a P^+ layer substrate called collector.

(i) Operation

When gate is positive with respect to emitter and emitter voltage greater than the threshold voltage of IGBT, a N-channel is formed in the P-region as in power MOSFET ($V_{GE} > V_T$, N-channel formed in P region).

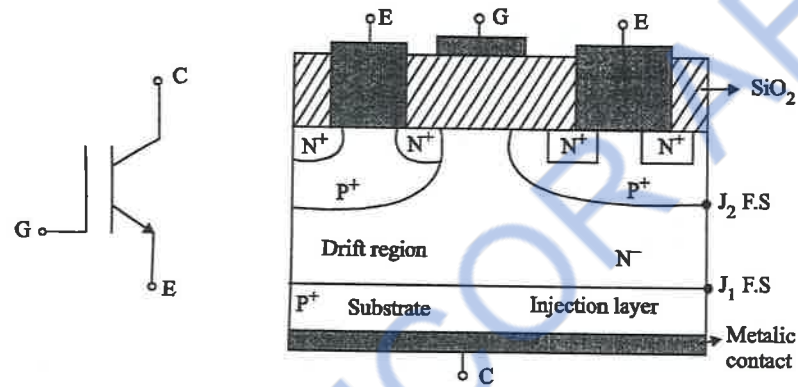

Fig. 3.41

Thus N -channel short circuits the N^- region with N^+ emitter region. As electron movement in the N -channel return, causes substantial hole injectors from P^+ substrate layer into that are epitaxial layer.

The three layers P^+ , N^- and P^+ constitute a PNP transistor with P^+ as emitter, N^- as bore and P as collector. Also P and N^+ layers constitute to NPN transistor.

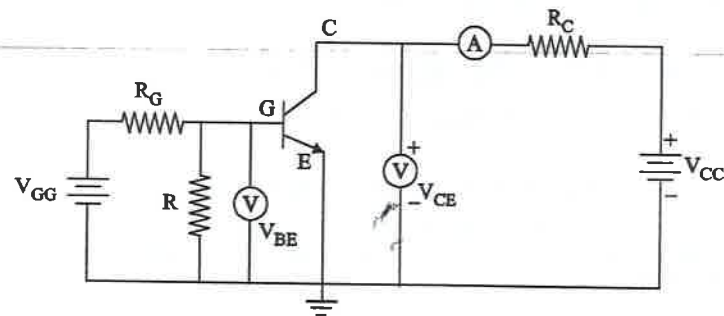

Fig. 3.42

(ii) V I transfer characteristics

Static $V-I$ characteristics of IGBT is shown in fig. 3.43. The plot of collector current, I_C Vs collector emitter voltage, V_{CE} for various values of gate emitter

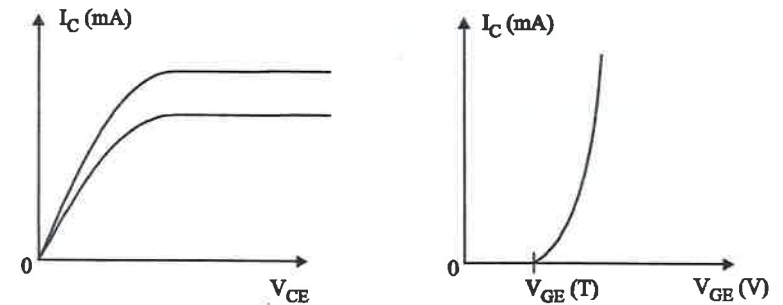

Fig. 3.43

voltage, V_{GE} . The slope of the output characteristics is similar to that of BJT. But here the controlling parameter is gate emitter voltage (V_{GE}). Hence IGBT is voltage-controlled device.

The transfer characteristics of an IGBT is a plot of collector current (I_C) Vs Gate-emitter voltage (V_{GE}) as in figure. This characteristics is similar to power MOSFET.

When $V_{GE} < V_T$, IGBT is in the off state. When the device is off, junction J_2 blocks forward voltage and in case reverse voltage appears across collector and emitter junction, J_1 blocks it.

(iii) Applications of IGBT

1. Used in SMPS
 2. Used in UPS
 3. Used for speed control of AC and DC motors.
- » Used in inverters
» Used in e -automobile system

3.9 INVERTER

The inverter is an electronic circuit that converts fixed DC supply to variable AC supply.

The inverter is used to run the AC loads through a battery.

Types

1. Single phase inverter
2. Three phase inverter

3.9.1 Single phase inverter

The single phase inverter is also called as half bridge rectifier. It converts DC supply to single phase AC supply. For this purpose two switching devices (SCR, MOSFET, IGBT) are used to convert DC to AC. Diodes and capacitance helps the circuit to operate smoothly.

(i) Working

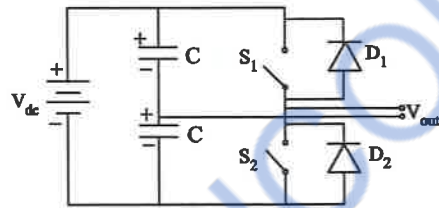

Fig. 3.44 Single phase inverter

In the half bridge inverter, the output varies from $+\frac{V_s}{2}$ to $-\frac{V_s}{2}$. As shown in the circuit, two switching devices are connected in one common branch. The switching device may be SCR, MOSFET or IGBT.

Generally in inverter, MOSFET is commonly used as switching device. Two switches S_1 and S_2 are used. To obtain one cycle of alternating voltage each device is triggered at one time. The other being off at the same time. For example to obtain the positive cycle, of alternating supply, device S_1 is turned ON, while S_2 is kept OFF.

Similarly to obtain negative cycle of alternating supply, device S_2 is turned ON while S_1 is kept off. The output wave is shown in figure.

(ii) Output waveform

As shown in the output waves, when S_1 is conducting from 0 to $\frac{T}{2}$, the output $+\frac{V_s}{2}$ is obtained. Similarly, the when S_2 is conducting from $\frac{T}{2}$ to T , the output $-\frac{V_s}{2}$ is obtained. Hence the output alternate between $+\frac{V_s}{2}$ to $-\frac{V_s}{2}$, which is regarded as alternating voltage, T is the total time period of the conduction of two devices.

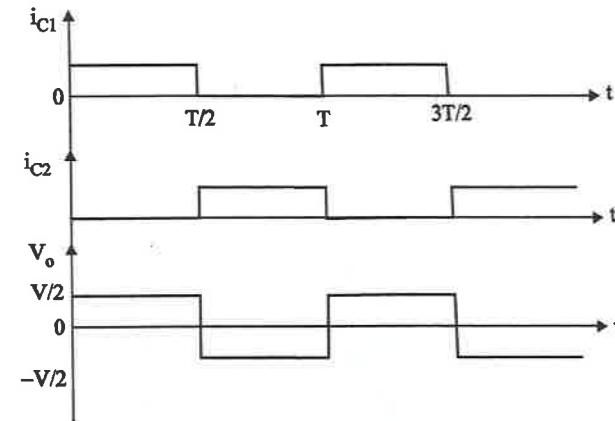

Fig. 3.45

It can be noted that the output voltage waveform is a stepped square waveform.

In inverters the stepped square waveform alternates between two valves, which is considered as alternating voltage.

(iii) Applications

1. Used in UPS
2. Used as speed control in DC motor
3. Used in high voltage DC systems (HVDC)
4. Used in refrigeration compressors
5. Used in solar power generation system.

3.10 RECTIFIERS

» The circuits which is used to convert a.c voltage to dc voltage are called 'Rectifiers'.

Block diagram:

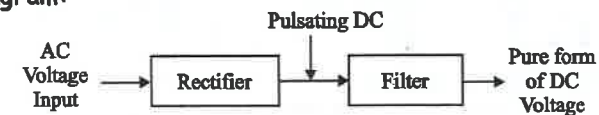

Fig. 3.46

» Types:

1. Half-wave rectifier
2. Centre tapped full-wave rectifier
3. Full-wave bridge rectifier

3.10.1 Half-wave rectifier

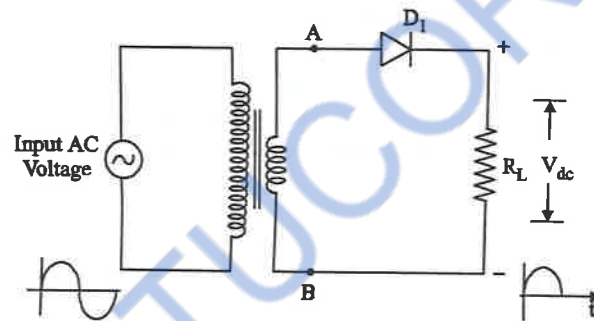

Fig. 3.47

- » It consists of transformer, diode and load resistance.
- » Here, diode acts as a switch i.e., under forward biasing condition, it is a closed switch and reverse biasing condition, it is an open switch.
- » The transformer used to step-down the a.c voltage (input/voltage).
- » Operation:

During +ve half cycle

- » During +ve half-cycle of the input voltage (0 to π), the point 'A' is +ve with respect to point 'B'.

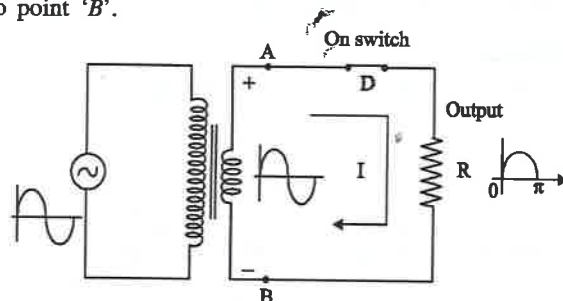

Fig. 3.48

- » During this period, the diode becomes forward biased and it acts as a (ON) closed switch.
- » The entire positive input voltage is applied across the load. The current path is A-D-R-B. It is shown in fig. 3.48.

During negative half cycle: (off) switch open circuit

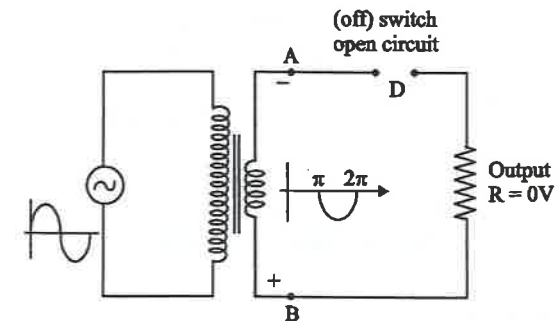

Fig. 3.49

- » During this period ($\pi - 2\pi$), the point 'B' is positive with respect to A.
- » In this period, Diode 'D' becomes reverse biased. Then it acts as an open switch. So, there is no output voltage across load. It is shown in fig. 3.49.

Input and output waveforms

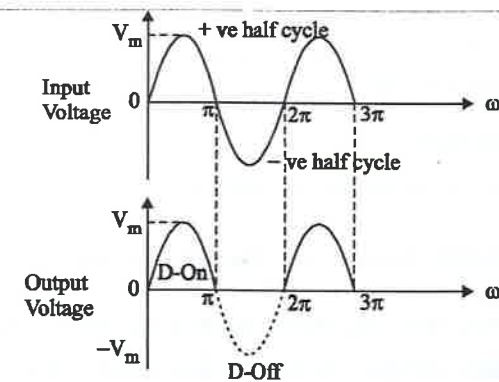

Fig. 3.50

During negative half cycle of the input voltage

3.10.2 Centre tapped full-wave rectifier

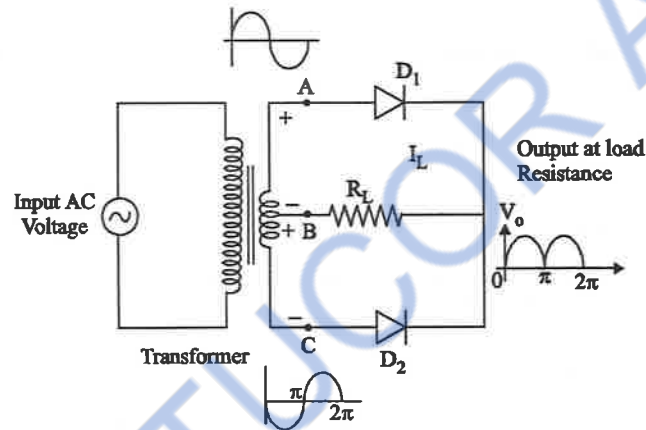

Fig. 3.51

- » The fig. shows the centre tapped fullwave rectifier circuit.
- » It consists of two diodes, one centre tapped transformer and load resistance.
- » By centre tapping, the secondary winding is divided into two equal parts.
- » Thus, the voltage available between A to B is 180° out of phase with the voltage available between B to C.

Operation

When an A.C voltage is applied to primary winding of transformer, as per the principle transformer, it transfers the primary voltage into secondary voltage without changing its frequency.

During positive half cycle

- » During positive half cycle of the input voltage, the terminal 'A' is more positive than terminal 'C'. Thus diode ' D_1 ' becomes more forward bias than diode ' D_2 '.
- » Thus, $D_1 \rightarrow$ acts as a closed switch, $D_2 \rightarrow$ acts as a open switch. The current path is $A - D_1 - R_L - B$.
- » Therefore, we can get positive output voltage.

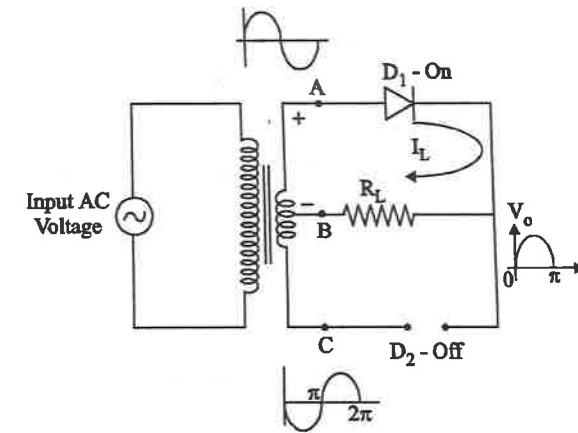

Fig. 3.52

During negative half-cycle

During negative half-cycle of the input voltage, the terminal 'C' is more positive than terminal 'A', thus, diode ' D_2 ' becomes more forward biased than diode ' D_1 '. Thus, diode ' D_2 ' acts as a closed switch and diode ' D_1 ' acts as a open switch.

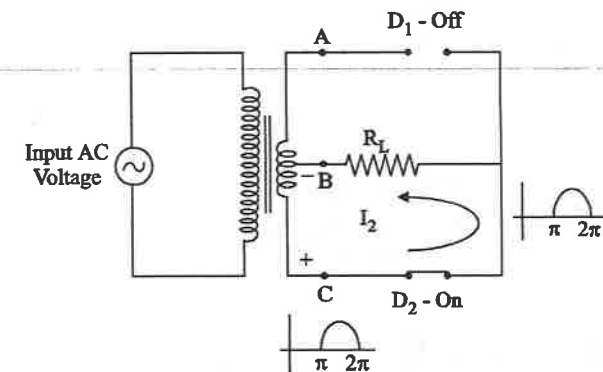
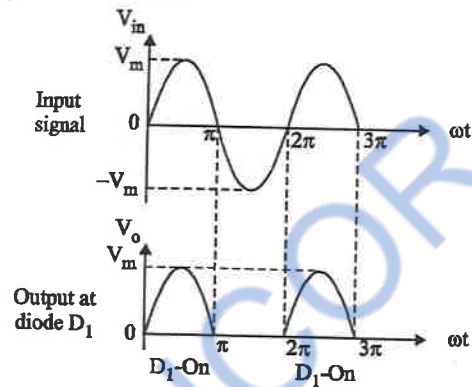

Fig. 3.53

- » Then the current is $C - D_2 - R_L - B$. Here, we can get positive output voltage across load. It is shown in below fig. 3.53.

Input and output waveforms



Input at 'D2'

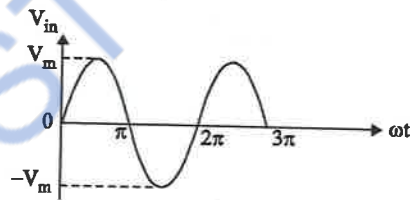

Output at 'D2'

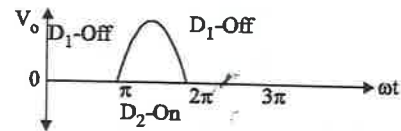

Final Output at D1 and D2

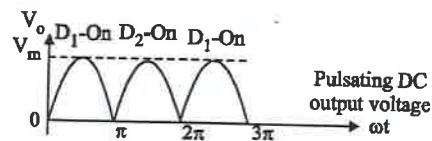

Note

The ripple frequency on a single phase full-wave rectifier is twice the supply frequency i.e., $2f$.

» If the supply frequency is 50 Hz, the ripple frequency of this rectifier is $2 \times 50 = 100$ Hz.

(i) Average output voltage (V_{dc})

Input voltage $V_{in} = V_m \sin \omega t$

Input current $I_{in} = I_m \sin \omega t$

DC (or) average voltage is of same form in the two half of the ac cycle. Hence, it is calculated for half cycle of input only.

$$\begin{aligned} V_{dc} &= \frac{1}{T} \int_0^{\pi} V_{in} d(\omega t) \\ &= \frac{1}{\pi} \int_0^{\pi} V_m \sin \omega t d(\omega t) \\ &= \frac{V_m}{\pi} \int_0^{\pi} \sin \omega t d(\omega t) \\ &= \frac{V_m}{\pi} (-\cos \omega t) \Big|_0^{\pi} = \frac{V_m}{\pi} [-\cos \pi - (-\cos 0)] \end{aligned}$$

$$V_{dc} = \frac{V_m}{\pi} [1 + 1] = \frac{2V_m}{\pi}$$

$$V_{dc} = \frac{2V_m}{\pi}$$

(ii) Average input current (I_{dc})

$$\begin{aligned} I_{dc} &= \frac{1}{T} \int_0^{\pi} I_{in} d(\omega t) \\ &= \frac{1}{\pi} \int_0^{\pi} I_m \sin \omega t d(\omega t) \end{aligned}$$

$$\frac{\frac{4I_m^2}{\pi^2}}{\frac{I_m^2}{2}} = \frac{8}{\pi^2} \times 100 = 81.1\%$$

$$SUF = (TUF)_s = 81.1\%$$

Transformer primary supplies input for both half cycle of input, thus

TUF for primary = $(TUF)_p$

$$= 2 \times 28.8\% = 57.2\%$$

$$\% TUF = \frac{(TUF)_p + (TUF)_s}{2} = 69.15\%$$

Advantages

1. The output voltage and transformer efficiency are high.
2. Low ripple factor.
3. High transformer utilisation factor.

Disadvantages

1. Usage of additional diode and bulky transformer is needed, and hence increase in cost.
2. The peak inverse voltage of diode is high ($2V_m$).

3.10.3 Full wave bridge rectifier

Diagram

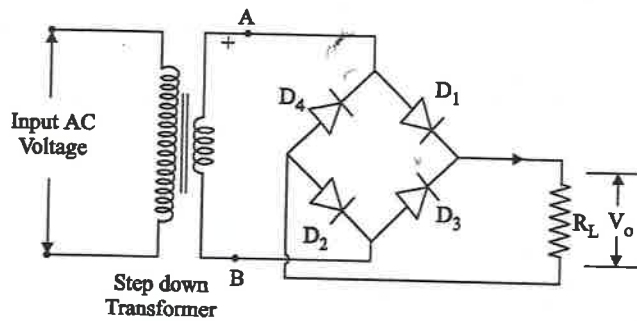

Fig. 3.54

Bridge rectifier diagram consists of one-step down transformer, 4-PN-Junction diode, and one load resistor (R_L).

Operation

- » During the positive half cycle of the input voltage, the terminal 'A' is positive with respect to 'B'. Thus, diodes D_1 and D_2 are in forward biasing and D_3 and D_4 are in reverse biasing.
- » Then the current flow is shown in below fig. 3.55.

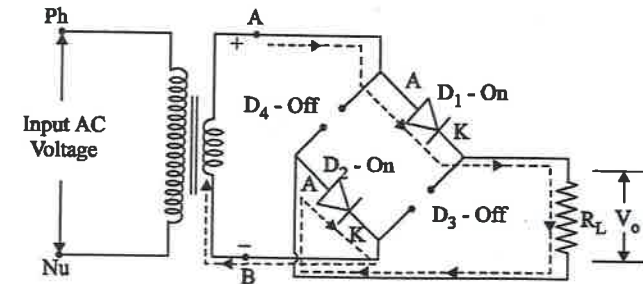

Fig. 3.55

- » During negative half cycle of the input voltage, the terminal 'B' is positive with respect to 'A'.
- » Thus, diodes D_3 and D_4 are forward biased and diodes D_1 and D_2 are reverse biased.
- » The current path is $B - D_3 - R_L - D_4 - A$
- » It is shown in below fig. 3.56

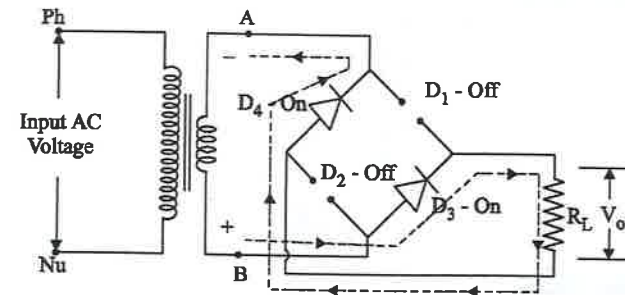

Fig. 3.56

Input and output waveforms

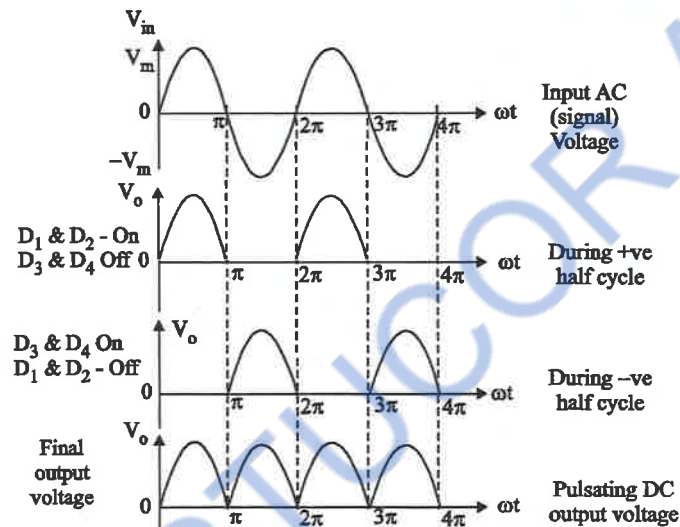

Fig. 3.57

Transformer utilisation factor (TUF)

It is defined as the ratio of dc power to the rated ac power.

$$\text{i.e., } TUF = \frac{P_{dc}}{P_{ac \text{ rated}}} = \frac{\left(\frac{2I_m}{\pi}\right)^2 \cdot R_L}{V_{0 \text{ rms}} \cdot I_{0 \text{ rms}}}$$

$$= \frac{\frac{4I_m^2}{\pi^2} \cdot R_L}{\frac{V_m}{\sqrt{2}} \cdot \frac{I_m}{\sqrt{2}}} = \frac{8}{\pi^2} \times 100 = 81.1\%$$

$$\boxed{TUF = 81.1\%}$$

- » In this case, centre tapped transformer is not required, hence secondary utilization factor itself defines the TUF.
- » Ripple factor and efficiency are same as full wave rectifier.

Advantages

1. Transformer with centre tap in secondary is not required.
2. Peak inverse voltage is share by $-D_1, D_2$ and D_3, D_4 combinations equivally.
3. Better transformer utilization factor.

Disadvantages

1. Additional 2-diodes are required
2. Efficiency is slightly reduced than the FWR.

The reverse voltage appearing across the reverse biased diodes is $2V_m$ but two diodes are sharing it.

Hence HIV rating of the diode is V_m and not $2V_m$ in case of full wave rectifier.

3.10.4 Comparison of HWR, FWR and Bridge Rectifier

Parameter	Hall wave rectifier	Centre tapper Full wave rectifier	Full wave Bridge rectifier
No. of diodes	One	Two	Four
Ripple frequency	f_s	$2f_s$	$2f_s$
PIV	V_m	$2V_m$	V_m
I_m	$\frac{V_m}{R_f + R_L}$	$\frac{V_m}{R_f + R_L}$	$\frac{V_m}{2R_f + R_L}$
Average current (I_{dc})	I_m/π	$2I_m/\pi$	$2I_m/\pi$
RMS value	$I_m/2$	$I_m/\sqrt{2}$	$I_m/\sqrt{2}$
DC value (V_{DC})	$\frac{V_m}{\pi} - I_{dc} R_f$	$\frac{2V_m}{\pi} - I_{dc} R_f$	$\frac{2V_m}{\pi} - 2I_{dc} R_f$
Ripple factor	1.21	0.482	0.482
P_{DC}	$I_{dc}^2 R_L$	$I_{dc}^2 R_L$	$I_{dc}^2 R_L$
P_{AC}	$I_{RMS}^2 (R_f + R_L)$	$I_{RMS}^2 (R_f + R_L)$	$I_{RMS}^2 (2R_f + R_L)$
Efficiency (η)	40.5%	81.0%	81.0%
TUF	0.286	0.692	0.812

$$\frac{4I_m^2}{\pi^2} = \frac{8}{\pi^2} \times 100 = 81.1\%$$

$$SUF = (TUF)_s = 81.1\%$$

Transformer primary supplies input for both half cycle of input, thus TUF for primary = $(TUF)_p$

$$= 2 \times 28.8\% = 57.2\%$$

$$\% TUF = \frac{(TUF)_p + (TUF)_s}{2} = 69.15\%$$

Advantages

1. The output voltage and transformer efficiency are high.
2. Low ripple factor.
3. High transformer utilisation factor.

Disadvantages

1. Usage of additional diode and bulky transformer is needed, and hence increase in cost.
2. The peak inverse voltage of diode is high ($2V_m$)

3.10.3 Full wave bridge rectifier

Diagram

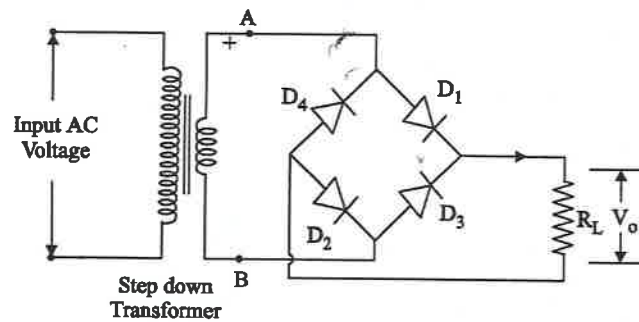

Fig. 3.54

Bridge rectifier diagram consists of one-step down transformer, 4-PN-Junction diode, and one load resistor (R_L).

Operation

- » During the positive half cycle of the input voltage, the terminal 'A' is positive with respect to 'B'. Thus, diodes D_1 and D_2 are in forward biasing and D_3 and D_4 are in reverse biasing.
- » Then the current flow is shown in below fig. 3.55.

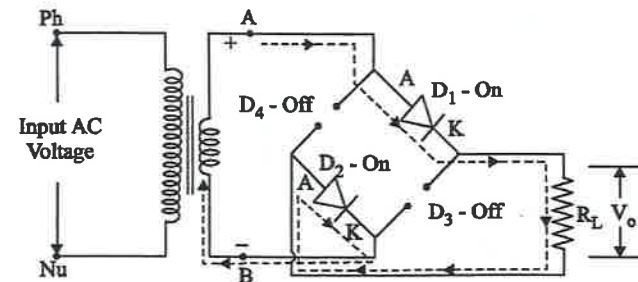

Fig. 3.55

- » During negative half cycle of the input voltage, the terminal 'B' is positive with respect to 'A'.
- » Thus, diodes D_3 and D_4 are forward biased and diodes D_1 and D_2 are reverse biased.
- » The current path is $B - D_3 - R_L - D_4 - A$
- » It is shown in below fig. 3.56

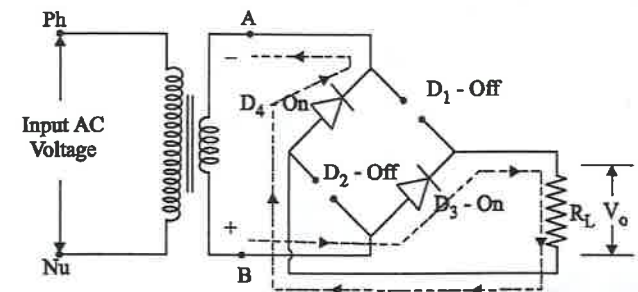

Fig. 3.56

Input and output waveforms

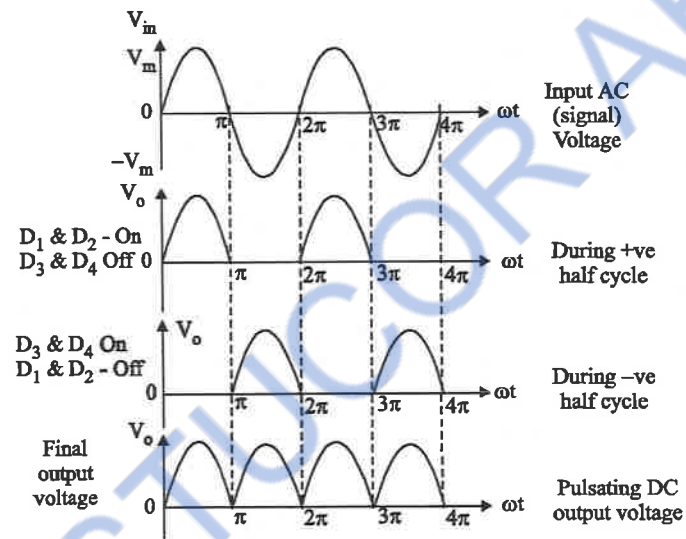

Fig. 3.57

Transformer utilisation factor (TUF)

It is defined as the ratio of dc power to the rated ac power.

$$\text{i.e., } TUF = \frac{P_{dc}}{P_{ac \text{ rated}}} = \frac{\left(\frac{2I_m}{\pi}\right)^2 \cdot R_L}{V_{0 \text{ rms}} \cdot I_{0 \text{ rms}}}$$

$$= \frac{\frac{4I_m^2}{\pi^2} \cdot R_L}{\frac{V_m}{\sqrt{2}} \cdot \frac{I_m}{\sqrt{2}}} = \frac{8}{\pi^2} \times 100 = 81.1\%$$

$$\boxed{TUF = 81.1\%}$$

- » In this case, centre tapped transformer is not required, hence secondary utilization factor itself defines the TUF.
- » Ripple factor and efficiency are same as full wave rectifier.

Advantages

1. Transformer with centre tap in secondary is not required.
2. Peak inverse voltage is share by $-D_1, D_2$ and D_3, D_4 combinations equivally.
3. Better transformer utilization factor.

Disadvantages

1. Additional 2-diodes are required
2. Efficiency is slightly reduced than the FWR.

The reverse voltage appearing across the reverse biased diodes is $2V_m$ but two diodes are sharing it.

Hence HIV rating of the diode is V_m and not $2V_m$ in case of full wave rectifier.

3.10.4 Comparison of HWR, FWR and Bridge Rectifier

Parameter	Half wave rectifier	Centre tapper Full wave rectifier	Full wave Bridge rectifier
No. of diodes	One	Two	Four
Ripple frequency	f_s	$2f_s$	$2f_s$
PIV	V_m	$2V_m$	V_m
I_m	$\frac{V_m}{R_f + R_L}$	$\frac{V_m}{R_f + R_L}$	$\frac{V_m}{2R_f + R_L}$
Average current (I_{dc})	I_m/π	$2I_m/\pi$	$2I_m/\pi$
RMS value	$I_m/2$	$I_m/\sqrt{2}$	$I_m/\sqrt{2}$
DC value (V_{DC})	$\frac{V_m}{\pi} - I_{dc} R_f$	$\frac{2V_m}{\pi} - I_{dc} R_f$	$\frac{2V_m}{\pi} - 2I_{dc} R_f$
Ripple factor	1.21	0.482	0.482
P_{DC}	$I_{dc}^2 R_L$	$I_{dc}^2 R_L$	$I_{dc}^2 R_L$
P_{AC}	$I_{RMS}^2 (R_f + R_L)$	$I_{RMS}^2 (R_f + R_L)$	$I_{RMS}^2 (2R_f + R_L)$
Efficiency (η)	40.5%	81.0%	81.0%
TUF	0.286	0.692	0.812

Unit-III

Explain the construction and working principle of transistor.

Two types of transistor are (i) NPN (ii) PNP.

Construction

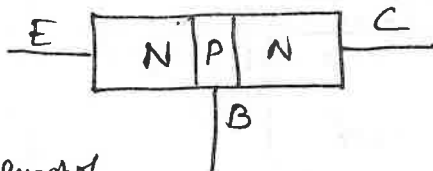

Symbol

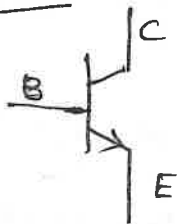

- Has 3 layers
- 'P' layer sandwiched between 2 'N' layers.
- Three terminals
- Emitter, Base, Collector
- Emitter is heavily doped
- Base is lightly doped
- Collector is moderately doped.
- Two PN jns are formed
- Emitter Base junction
- Collector Base junction
- EB jn is forward biased
- CB jn is reverse biased.

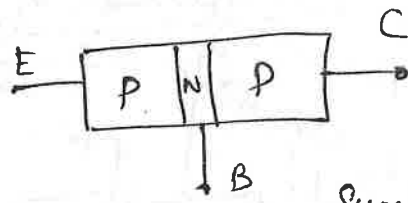

Symbol

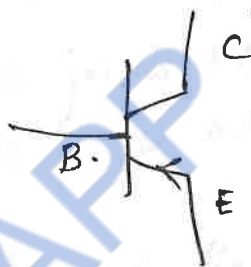

- Has 3 layers
- N layer is kept between 2 'P' layers.
- Three terminals
- Emitter Base Collector
- Emitter is heavily doped
- Base is lightly doped
- Collector is moderately doped
- Two PN jns are formed.
- Emitter Base junction
- Collector Base junction
- EB jn is forward biased
- CB jn is reverse biased.

• Transistor is BJT - Bipolar Junction Transistor
In transistor, current conduction is by both majority and minority carriers. So it is called Bipolar Junction Transistor

- The arrow mark in the symbol shows the direction of current flow.

Operation of NPN

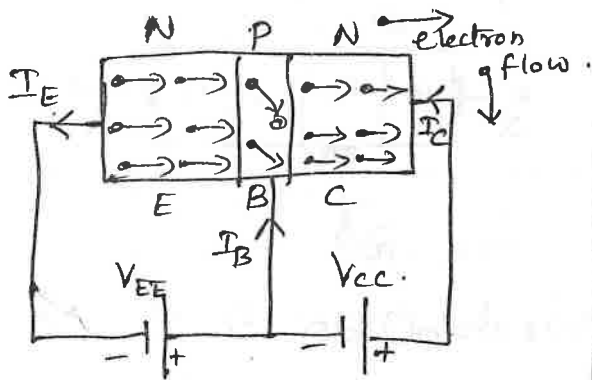

EB jn is FB
CB jn is RB.

Electrons are the majority carriers in emitter.

Electrons from 'E' move towards Base

- Some of the electrons combine with holes in Base
 - I_B flows.
 - Remaining electrons flow to the collector region
 - I_C flows.
 - Direction of current flow is opposite to the flow of electrons
- $$I_E = I_B + I_C$$

Operation of PNP Transistor

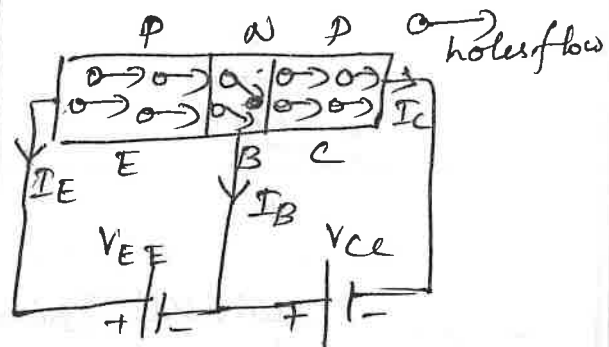

EB jn is FB
CB jn is RB

holes are the majority carriers in emitter.

Hole in 'E' move towards Base region

- Some of the holes combine with electrons in Base
- I_B flows
- Remaining holes flow to the collector region
- I_C flows
- $I_E = I_B + I_C$.
- Direction of current flow is same in the direction of holes flow

SCR - Silicon Controlled Rectifier

Construction

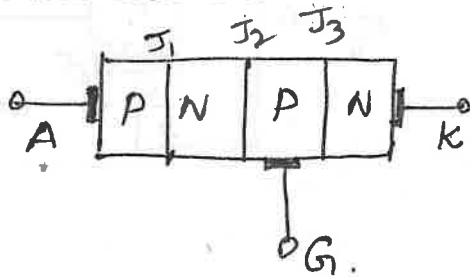

Symbol

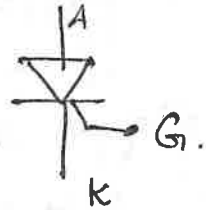

- SCR is an Unidirectional Device
- 4 layer PNP device. Three terminal (Emitter, base, collector)
- 3 Jns J_1, J_2, J_3 . ($J_n \rightarrow$ Junctions)
- Anode is taken from outermost P layer
- Cathode is taken from Outermost N layer.
- Gate is taken from middle p layer.
- Current operated device.

Operation of SCR.

(i) Gate is open.

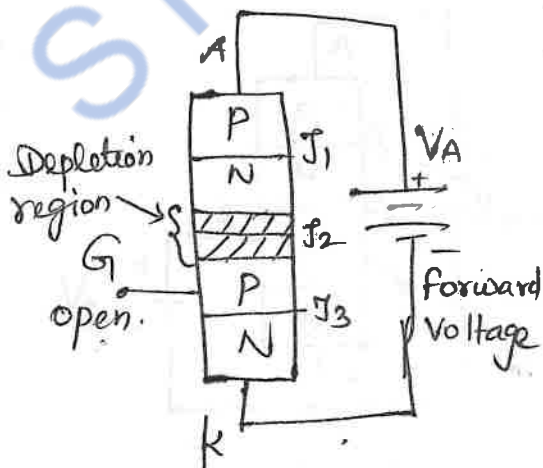

- Anode is '+' w.r.t cathode
- Gate is open
- J_1, J_3 are FB
- J_2 is RB.
- Depletion region around J_2 is produced.
- SCR is in OFF state
- Called forward blocking state.
- Voltage applied to A & K with anode '+' is called forward voltage.

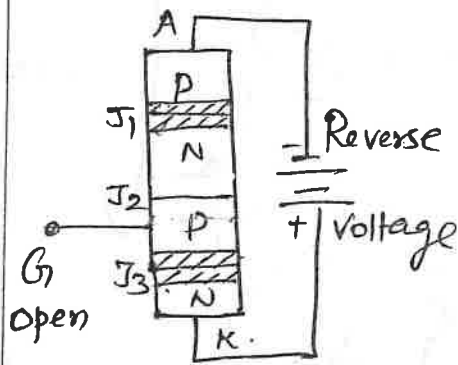

- Cathode is '+' w.r.t Anode
- Gate is open
- J_1, J_3 - RB, J_2 - FB.
- SCR is in OFF state
- Called Reverse Blocking state [RBS].
- Voltage applied to A & K with Cathode '+' is called Reverse Voltage.

In forward blocking state, if V_A is increased, junction J_2 breaks down SCR starts to conduct heavily.

The ^{forward} voltage at which SCR starts to conduct heavily when the gate is open is called forward breakover voltage.

When Gate is closed,

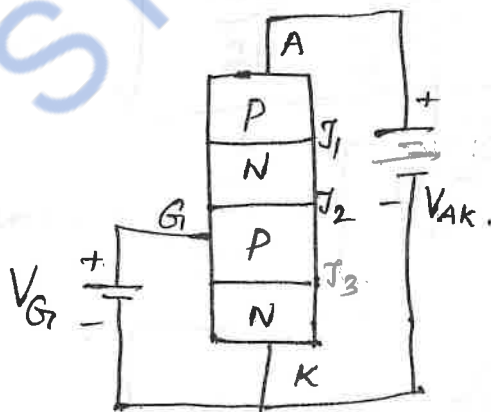

- Gate is '+'
- electrons from 'K' move towards '+'
- Holes from 'A' move towards '-'
- Anode current increases
- Junction J_2 breaks
- SCR conducts heavily.

VI characteristics I_F

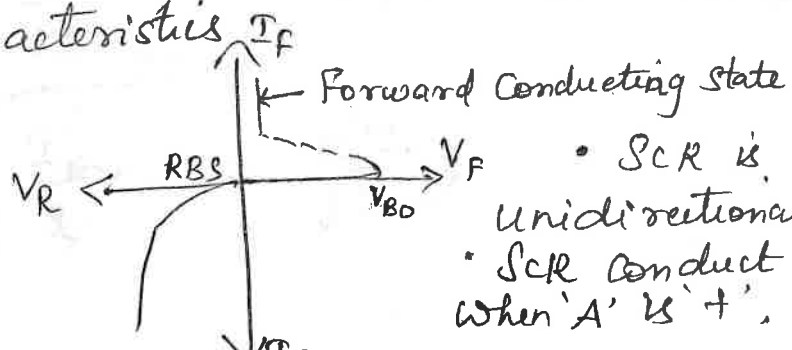

- SCR is a unidirectional device.
- SCR conduct only when 'A' is '+',

Unit-4

Digital Electronics

What is a digital signal?

A signal (V or I) which can have only two discrete values are called a digital signal.

What are the advantages of digital Electronics?

1. Digital circuits provide greater accuracy and precision.
2. Low Power Consumption
3. Fast and more efficient
4. Easily designed.
5. Storage of information is easy.
6. Digital circuits are less affected by noise.

Representation of Numbers of different radix.

1. Decimal Number System
 - Composed of 10 digits
 - 0, 1, 2, 3, 4, 5, 6, 7, 8, 9,
 - Base 10.
2. Binary Number System
 - Two digits (0 or 1)
 - Base 2.
 - Information is either True (or) False.
3. Octal Number System
 - Composed of 8 digits
 - 0, 1, 2, 3, 4, 5, 6, 7
 - Base 8.

4. Hexa decimal Number System

→ Composed of 16 digits

→ 0, 1, 2, 3, 4, 5, 6, 7, 8, 9, A, B, C, D, E, F

→ base (or) power (or) radix 16.

Conversion of Numbers.

① Decimal to binary

$$(34.45)_{10} = ?$$

$$\begin{array}{r} 2 \overline{) 34} \\ \underline{2 \ 17 - 0} \\ 2 \overline{) 8 - 1} \\ \underline{2 \ 4 - 0} \\ 2 \overline{) 2 - 0} \\ \underline{1 - 0} \end{array} \quad \uparrow \quad (34)_{10} = (100010)_2$$

$$\begin{array}{r} 0.45 \times 2 = 0.90 \quad 0 \\ 0.90 \times 2 = 1.80 \quad 1 \\ 0.80 \times 2 = 1.60 \quad 1 \\ 0.60 \times 2 = 1.20 \quad 1 \\ 0.20 \times 2 = 0.40 \quad 0 \end{array} \quad \downarrow$$

$$(34.45)_{10} = (100010.01110)_2$$

② Binary to decimal

$$(11110.0101)_2$$

$$\begin{array}{cccccc} 1 & 1 & 1 & 1 & 0 & \\ 2^4 & 2^3 & 2^2 & 2^1 & 2^0 & \\ 1 \times 2^4 + 1 \times 2^3 + 1 \times 2^2 + 1 \times 2^1 & & & & & \\ = 30. & & & & & \end{array}$$

$$\begin{array}{r} 0.101 \\ 2^{-1} \ 2^{-2} \ 2^{-3} \ 2^{-4} \\ 1 \times 2^{-1} + 1 \times 2^{-2} \\ = 0.3125 \end{array}$$

$$(11110.0101)_2 = (30.3125)_{10}$$

③ Decimal into octal

$$(232.52)_{10} = ?$$

$$\begin{array}{r} 8 \overline{) 232} \\ \underline{8 \ 29 - 0} \\ 3 - 5 \end{array} \quad \uparrow \quad (232)_{10} = (350)_8$$

$$\begin{array}{r} 0.52 \times 8 = 4.16 \quad 4 \\ 0.16 \times 8 = 1.28 \quad 1 \\ 0.28 \times 8 = 2.24 \quad 2 \\ 0.24 \times 8 = 1.92 \quad 1 \end{array} \quad \downarrow$$

$$(232.52)_{10} = (350.4121)_8$$

④ Octal into decimal

$$(3714.27)_8 = ?$$

$$\begin{array}{cccc} 3 & 7 & 1 & 4 \\ 8^3 & 8^2 & 8^1 & 8^0 \\ 3 \times 8^3 + 7 \times 8^2 + 1 \times 8^1 + 4 \times 8^0 \\ = 1996. \end{array}$$

$$\begin{array}{r} 0.27 \\ 8^{-1} \ 8^{-2} \\ 2 \times 8^{-1} + 7 \times 8^{-2} \\ = 0.359 \end{array}$$

$$(3714.27)_8 = (1996.359)_{10}$$

②

⑤ Decimal to Hexadecimal
 $(491.62)_{10} = ?$

$$\begin{array}{r} 16 \overline{) 491} \\ \underline{30} - 10(B) \uparrow \\ \underline{1} - 14(E) \end{array}$$

$$\begin{array}{l} 0.62 \times 16 = 9.92 \quad 9 \\ 0.92 \times 16 = 14.72 \quad E(14) \\ 0.72 \times 16 = 11.52 \quad B(11) \end{array}$$

$$(491.62)_{10} = (1EB.9EB)_{16}$$

⑥ Hexadecimal to decimal
 $(B9A.C)_{16} = ?$

$$\begin{array}{ccc} B & 9 & A \\ 16^2 & 16^1 & 16^0 \end{array}$$

$$B \times 16^2 + 9 \times 16^1 + A \times 16^0$$

$$= 11 \times 16^2 + 9 \times 16^1 + 10 \times 16^0$$

$$= 2970$$

$$\begin{array}{c} C \\ 16^{-1} \\ C \times 16^{-1} \\ 12 \times 16^{-1} = 0.75 \end{array}$$

$$(B9A.C)_{16} = (2970.75)_{10}$$

⑦ Octal to binary

$$(645.1)_8 = ?$$

$$\begin{array}{cccc} 6 & 4 & 5 & . & 1 \\ 110 & 100 & 101 & & 001 \end{array}$$

$$(645.1)_8 = (110100101.001)_2$$

⑧ Binary to octal
 $(10101101.111)_2$

$$\begin{array}{ccccccc} 010 & 1011 & 01 & . & 111 \\ \underline{\quad} & \underline{\quad} & \underline{\quad} & & \underline{\quad} \\ 2 & 5 & 5 & & 7 \end{array}$$

$$(10101101.111)_2 = (255.7)_8$$

⑧ Hexadecimal to binary

$$(3AC.E)_{16} = ?$$

$$\begin{array}{cccc} 3 & A & C & . & E \\ 0011 & 1010 & 1100 & & 1110 \end{array}$$

$$(3AC.E)_{16} = (001110101100.1110)_2$$

⑨ Binary to hexadecimal
 $(101110001)_2$

$$\begin{array}{ccccccc} 0001 & 0111 & 0001 \\ \underline{\quad} & \underline{\quad} & \underline{\quad} \\ 1 & 7 & 1 \end{array}$$

$$(101110001)_2 = (171)_{16}$$

⑩

Octal to Hexadecimal

$$(625.2)_8 = ?$$

$$6 \quad 2 \quad 5 \quad . \quad 2$$

$$\underline{110} \quad \underline{010} \quad \underline{101} \quad . \quad 010$$

$$0001 \quad 1001 \quad 0101 \quad . \quad 0100$$

$$1 \quad 9 \quad 5 \quad . \quad 4$$

$$(625.2)_8 = (195.4)_{16}$$

Hexadecimal to Octal

$$(3AE.2)_{16} = ?$$

$$3 \quad A \quad E \quad . \quad F$$

$$0011 \quad 1010 \quad 1100 \quad . \quad 1110$$

$$\underline{0011} \quad \underline{1010} \quad \underline{10100} \quad . \quad \underline{111000}$$

$$1 \quad 6 \quad 5 \quad 4 \quad . \quad 7 \quad 0$$

$$(3AE.F)_{16} = (1654.7)_{10}$$

1's Complements

1's Complement of a binary number is obtained by substituting '1' by '0' and '0' by '1'.

$$110101 \rightarrow \text{Number}$$

$$001010 \rightarrow \text{1's complement of number}$$

2's Complement

2's Complement of a binary number is obtained by

(i) Convert the number to 1's complement

(ii) Add '1' to this 1's complement

$$\text{Number} \rightarrow 110101$$

$$\text{1's Complement} \rightarrow 001010 +$$

$$\text{2's Complement} \rightarrow \underline{\underline{001011}}$$

Signed Binary numbers.

Both positive and negative numbers are represented by only binary digits.

Left most bit in the number represent sign of the numbers.

Sign bit 0 \rightarrow positive numbers

Sign bit 1 \rightarrow Negative numbers

B_7 B_6 B_5 B_4 B_3 B_2 B_1 B_0
 Sign bit } Magnitude bits

Maximum '+' numbers $0\ 111\ 1111 \rightarrow +127$

Maximum '-' numbers $1\ 111\ 1111 \rightarrow -127$

Perform addition of $(1100\ 1100)_2$ and $(1101\ 1010)_2$

$$\begin{array}{r}
 1\ 1\ 0\ 0\ 1\ 1\ 0\ 0 \\
 +\ 1\ 1\ 0\ 1\ 1\ 0\ 1\ 0 \\
 \hline
 1\ 1\ 0\ 1\ 0\ 0\ 1\ 1\ 0
 \end{array}$$

Add $(28)_{10}$ and $(15)_{10}$ by converting them into binary

$$\begin{array}{r}
 2 \overline{)28} \\
 \underline{2\ 14} - 0 \\
 2 \overline{)7} - 0 \\
 2 \overline{)3} - 1 \\
 \underline{1} - 1
 \end{array}$$

$$\begin{array}{r}
 2 \overline{)15} \\
 \underline{2\ 7} - 1 \\
 2 \overline{)3} - 1 \\
 \underline{1} - 1
 \end{array}$$

$(15)_{10} = (01111)_2$

$(28)_{10} = (011100)_2$

$$\begin{array}{r}
 0\ 0\ 1\ 1\ 1\ 0\ 0\ 0 \\
 +\ 0\ 0\ 1\ 1\ 1\ 1 \\
 \hline
 0\ 1\ 0\ 1\ 0\ 1\ 1 \rightarrow +43
 \end{array}$$

Performs $(1110\ 1100)_2 - (0011\ 0010)_2$ using 1's complement.

1110 1100₊ - Number 1

1100 1101 - 1's complement of number 2.

1 1011 1001₊

1011 1010

Using 2's Complement Performs $(42)_{10} - (68)_{10}$

2 | 68
 2 | 34 - 0
 2 | 17 - 0
 2 | 8 - 0
 2 | 4 - 0
 2 | 2 - 0
 1 - 0

2 | 42
 2 | 21 - 0
 2 | 10 - 1
 2 | 5 - 0
 2 | 2 - 1
 1 - 0

$(68)_{10} = (1000100)_2$

$(42)_{10} = (101010)_2$

2's complement for 68

42 → 101010₊

1's complement of 68 = 0111011₊

68 → 0111100

1 100110

↓
 2's complement of (-26).

2's complement of 68 = 0111100

1's complement → 0011001₊

2's complement of (+26)₁₀ = 0011010

Codes:

Code is a Symbolic representation of discrete information like letters, numbers and special characters.

Types of codes are

- (i) Weighted Binary code
- (ii) Nonweighted Binary code
- (iii) Error detecting code
- (iv) Error Correcting code.
- (v) Alphanumeric code.

(i) Weighted Binary codes.

- Position of each digit of a number represents a specific weight.
- Each digit has a weight 8, 4, 2 or 1.
- Each decimal digit is represented by a group of four bits.

BCD code - Binary Coded Decimal.

Decimal No	8	4	2	1	8	1000
0	0	0	0	0	9	1001
1	0	0	0	1		
2	0	0	1	0		
3	0	0	1	1		
4	0	1	0	0		
5	0	1	0	1		
6	0	1	1	0		
7	0	1	1	1		

29 2 4 = (0010 0100)

(9) (8421 BCD)

Non weighted codes

The code which doesn't have weights is called non-weighted codes.

1. Excess 3 code.

obtained by adding 3 (0110) with the BCD code

Decimal NO	BCD Code	Excess 3 code
0	0000	0011
1	0001	0100
2	0010	0101
3	0011	0110
4	0100	0111
5	0101	1000
6	0110	1001
7	0111	1010
8	1000	1011
9	1001	1100

2. Gray code.

obtained by changing only one bit at a time

Decimal No	Binary Code	Gray Code
0	0000	0000
1	0001	0001
2	0010	0011
3	0011	0010
4	0100	0110
5	0101	0111
6	0110	0101
7	0111	0100
8	1000	1100
9	1001	1101
10	1010	1101
11	1011	1110
12	1100	1110
13	1101	1111
14	1110	1111
15	1111	1111

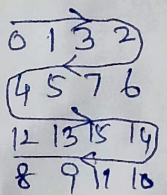

③ Gray Code - Obtained by changing one bit at a time

Numbers	Binary code	Gray code
0	0000	0000
1	0001	0001
2	0010	0011
3	0011	0010
4	0100	0110
5	0101	0111
6	0110	0101
7	0111	0100
8	1000	1100
9	1001	1101
10	1010	1111
11	1011	1110
12	1100	1010
13	1101	1011
14	1110	1001
15	1111	1000

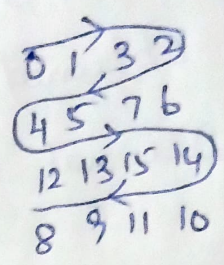

STUDYOR APP

Error detection and Correction codes:-

- When the digital information in the binary form is transmitted from one circuit to another circuit, an error may occur.
- To maintain the data integrity between transmitter and receiver, an extra bit or more than 1 bits are added in the data.
- These extra bits allow the detection and some times correction of errors in the data.
- Codes which detect errors - error detecting codes.
- Codes which detect and correct error is called error detecting and correcting codes.

Parity Bit

- Error detecting code during transmission.
- Extra bit included with the binary message to make number of one's either odd or even
- Message including the parity bit is transmitted and then checked at the receiving end for errors.
- An error is detected if the checked parity does not correspond with the one transmitted
- Circuit that generates parity bit in the transmitter is called parity generator

- Circuit that checks the parity in the receiver is called parity checker.
- Even parity \rightarrow added parity makes number of one's is even
- odd parity \rightarrow added parity makes number of one's is odd
- XOR gate is used to generate parity bit.

Even parity

ASCII Code	Parity bit	Message Transmitted
1000001	0	01000001
1000011	1	11000011
1000100	1	11000100
1000010	1	11000010
1000011	0	01000011

Odd parity

- During transmission, the sender and receiver must both agree to use parity checking and there will be agreement whether parity is to be odd or even.
- If sender and receiver are not configured with the same parity, communication will be impossible.
- Used in communication, testing memory storage devices.

Errors Detecting Codes:- Hamming Code.

- One or more parity bits are added to the data in such a way that errors can be detected and corrected.
- Hamming code uses a number of parity bits located at certain positions in the code.

Steps to solve Hamming code problem.

(i) Number of parity bits

$$2^p \geq x + p + 1. \quad \text{--- (1)}$$

Where x = No. of information

p - No. of parity bits

for example, if $x=4$, p is found by trial and error

If $p=1$, $2^1 \geq 4+1+1$ not satisfied.

$p=2$ $2^2 \geq 4+2+1$ not satisfied

$p=3$ $2^3 \geq 4+3+1$ satisfied.

$$p=3.$$

(ii) Location of the parity bits

$$x=4, p=3.$$

$$\text{Code} = 4+3 = 7 \text{ bits}$$

$B_7 \ B_6 \ B_5 \ B_4 \ B_3 \ B_2 \ B_1$

Location of parity bits are ascending powers of 2 (1, 2, 4, 8 ...).

$D_7 \ D_6 \ D_5 \ P_4 \ D_3 \ P_2 \ P_1$

P - parity bit.

D - Information bit.

(iii) Assigning values to Parity bit.

Bit location	7	6	5	4	3	2	1
Bit designation	D_7	D_6	D_5	P_4	D_3	P_2	P_1
Binary Numbers	111	110	101	100	011	010	001

P_1 (001) has '1' in the LSB.
 So bits having '1' as LSB are taken into account. (ie) D_3 (011) D_5 (101) D_7 (111)

$$P_1 = 001 = D_3, D_5, D_7$$

$$P_2 = 010 = D_3, D_6, D_7 \text{ ('1' in the middle)}$$

$$P_4 = 100 = D_5, D_6, D_7 \text{ ('1' in the MSB)}$$

(iv) Hamming code Table.

Bit Location	7	6	5	4	3	2	1
Bit designation	D_7	D_6	D_5	P_4	D_3	P_2	P_1
Binary Numbers	111	110	101	100	011	010	001
Information Bit							
Parity Bit							

Ex Information is $X = 10111$ [odd parity]

$$2^4 \geq 5+4+1 \therefore P=4, \text{ Total bits} = 5+4=9.$$

Parity - P_1, P_2, P_4, P_8

$$P_1 - D_3, D_5, D_7, D_9 - 1101 \rightarrow P_1 = 0$$

$$P_2 - D_3, D_6, D_7 - 110 \rightarrow P_2 = 1$$

$$P_4 - D_5, D_6, D_7 - 011 \rightarrow P_4 = 1$$

$$P_8 - D_9 - 1 \rightarrow P_8 = 0$$

9	8	7	6	5	4	3	2	1
D_9	P_8	D_7	D_6	D_5	P_4	D_3	P_2	P_1
1	0	1	1	1	1	1	1	0

Introduction to "Karnaugh Map"

K Map

- K map is a mapping method for minimization of boolean variable.
- Only one variable is allowed to change across adjacent squares.
- K map can be formed for 2, 3, 4, 5 variables.
- Grouping of square should be done only in the order of 2^n where $n \rightarrow 0, 1, 2, 3, \dots$

① Simplify using K Map.

$$F(a, b, c, d) = \sum m(7, 9, 10, 11, 12, 13, 14, 15)$$

A boolean variable inside a square is termed as min term.

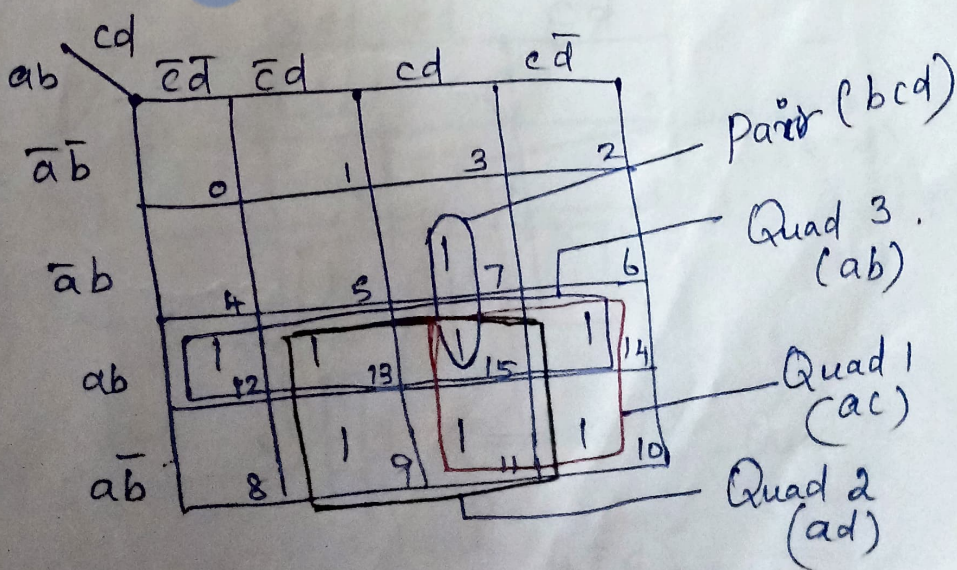

$$Y = ad + ac + ab + bcd.$$

(14)

2) $F = (a, b, c, d) = \sum m(0, 1, 2, 3, 4, 5, 6, 7, 9, 11)$

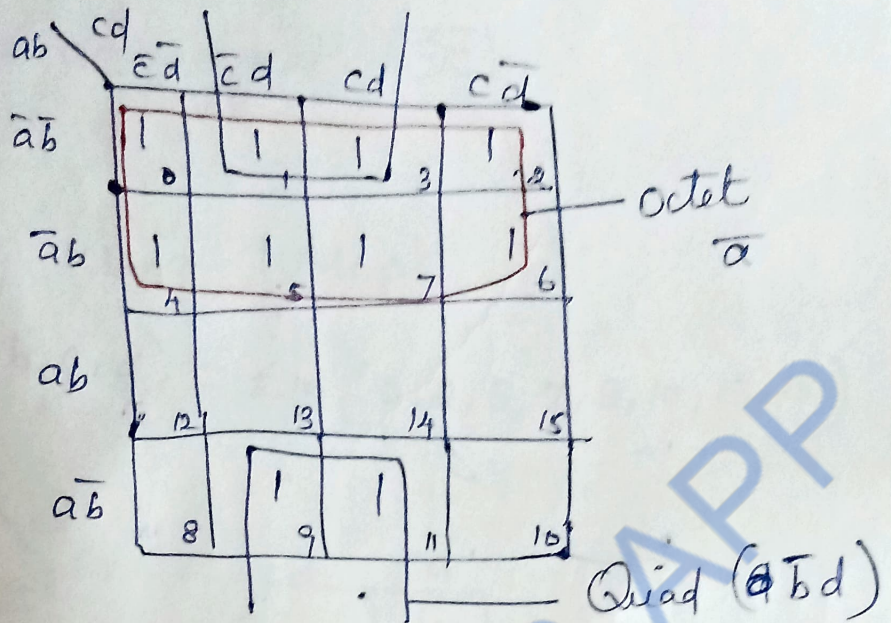

$$y = \bar{a} + \bar{b}d.$$

3. $F(a, b, c, d) = \sum m(1, 7, 9, 10, 11, 13, 14, 15)$

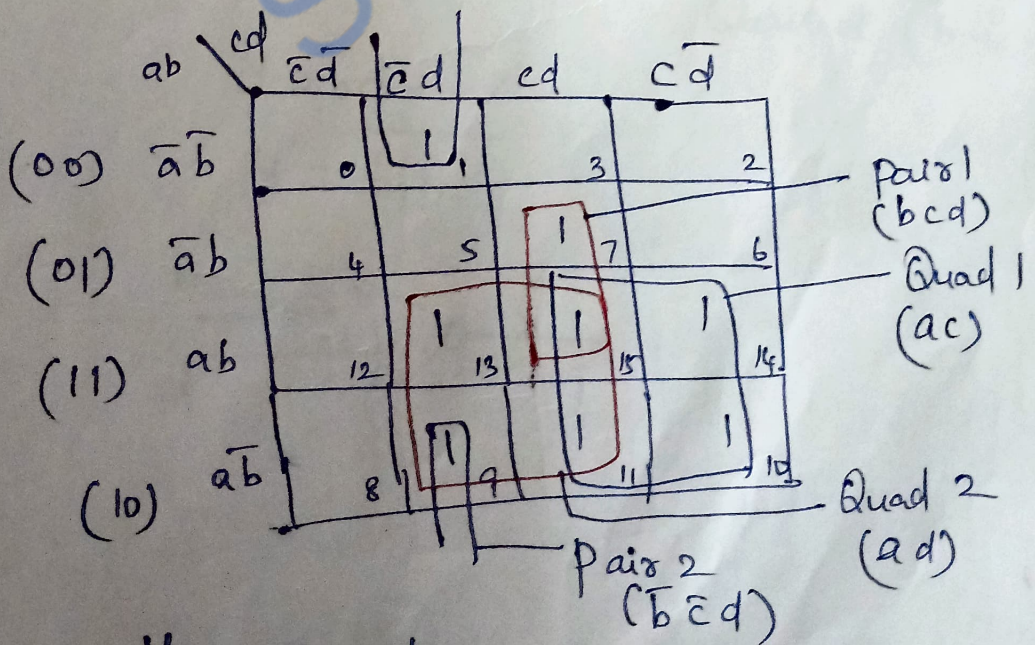

$$y = ac + ad + bcd + \bar{b}\bar{c}d$$

$$y = ac + ad + d(bc + \bar{b}\bar{c}) = y$$

$$y = ac + ad + bcd + \bar{b}\bar{c}d$$

$$= ac + ad + d(bc + \bar{b}\bar{c})$$

$$y = ac + ad + d(\overline{b \oplus c})$$

4. ✓ Simplify using KMap.

$$F(a, b, c, d) = \sum m(0, 2, 5, 7, 8, 10, 13, 15)$$

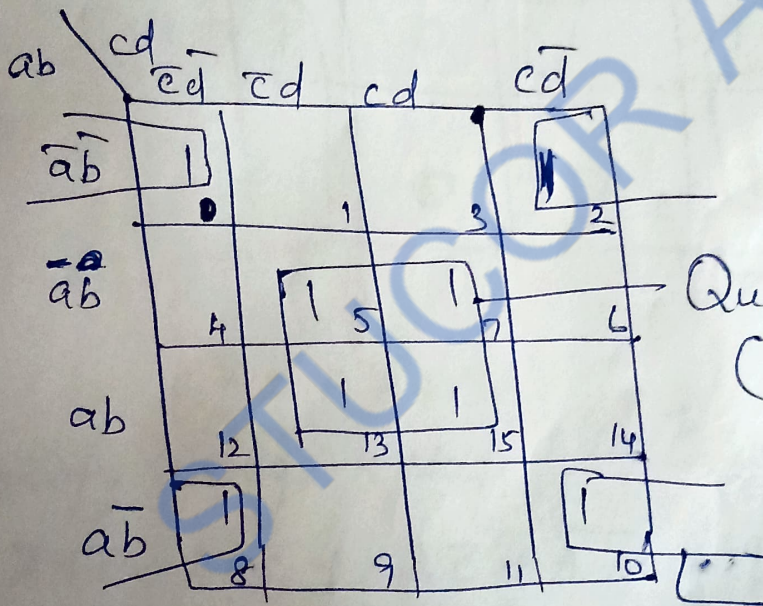

Quad 2 ($\bar{b}d$)

$$y = bd + \bar{b}d$$

$$y = \overline{b \oplus d}$$

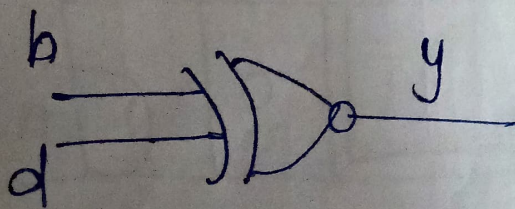

5) Simplify using k Map

$$Y = \bar{A}B + \bar{A}\bar{B}\bar{C} + A\bar{B}\bar{C} + A\bar{B}C$$

$$= \bar{A}B(C + \bar{C}) + \bar{A}\bar{B}\bar{C} + A\bar{B}\bar{C} + A\bar{B}C$$

$$Y = \bar{A}BC + \bar{A}B\bar{C} + \bar{A}\bar{B}\bar{C} + A\bar{B}\bar{C} + A\bar{B}C$$

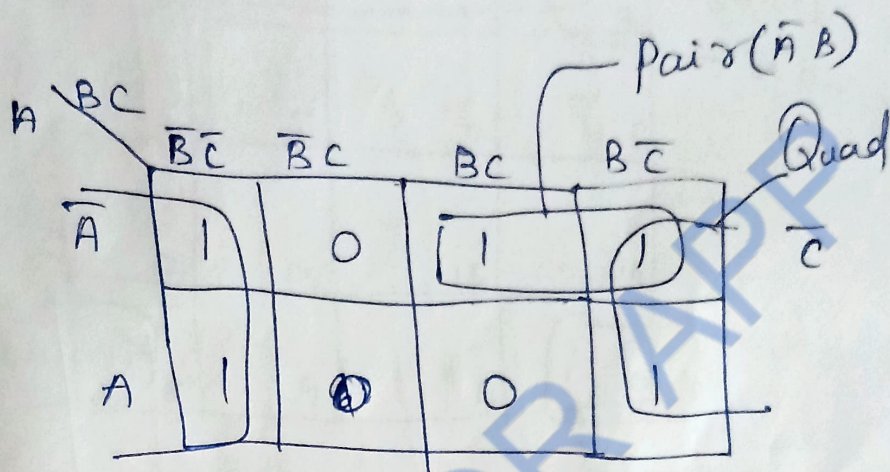

$$Y = \bar{A}B + C$$

6) Simplify using k Map

$$Y = \bar{A}\bar{B}\bar{C} + A\bar{B}\bar{C} + A\bar{B}C + \bar{A}\bar{B}C + \bar{A}BC + ABC$$

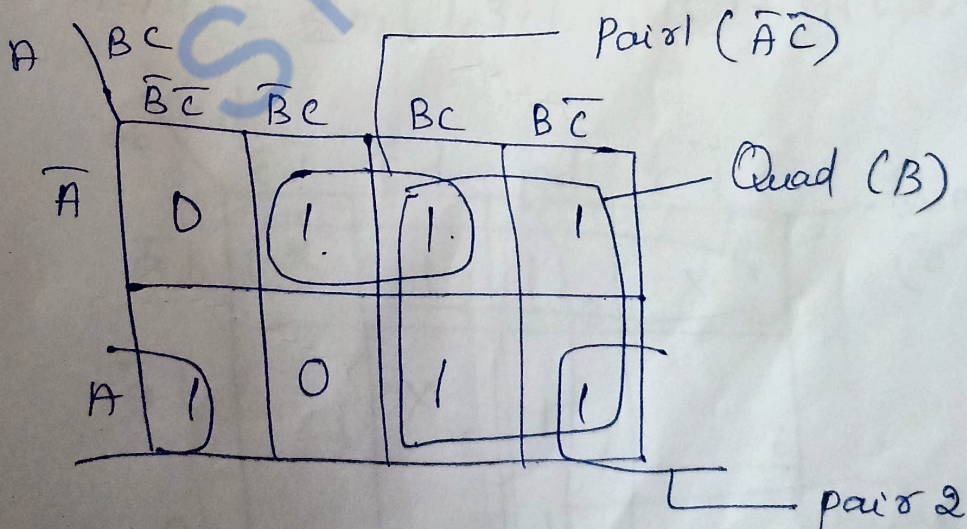

$$Y = B + A\bar{C} + \bar{A}C$$

$$Y = B + (A \oplus C)$$

7) $F(a, b, c, d) = \sum m(1, 3, 10) + d(0, 2, 8, 12)$

ab \ cd	$\bar{c}\bar{d}$	$\bar{c}d$	cd	$c\bar{d}$
$\bar{a}\bar{b}$	(X) 0	1	1 3	(X) 2
$\bar{a}b$	4	5	7	6
ab	X 12	13	15	14
$a\bar{b}$	(X) 8	9	11	(1) 10

Quad 1.
 $\bar{a}\bar{b}$

Quad 2
($\bar{b}\bar{d}$)

$$y = \bar{a}\bar{b} + \bar{b}\bar{d}$$

8) $F(a, b, c, d) = \sum m(1, 3, 7, 11, 15) + d(0, 2, 5)$

ab \ cd	$\bar{c}\bar{d}$	$\bar{c}d$	cd	$c\bar{d}$
$\bar{a}\bar{b}$	(X) 0	1	(1) 3	(X) 2
$\bar{a}b$	4	X 5	1 7	6
ab	12	13	1 15	14
$a\bar{b}$	8	9	1 11	10

Quad 1
($\bar{a}\bar{b}$)

Quad 2
 cd .

$$y = \bar{a}\bar{b} + cd$$

9

Reduce the following pos function using kmap technique.

$$f(A, B, C, D) = \pi M(0, 2, 3, 8, 9, 12, 13, 15)$$

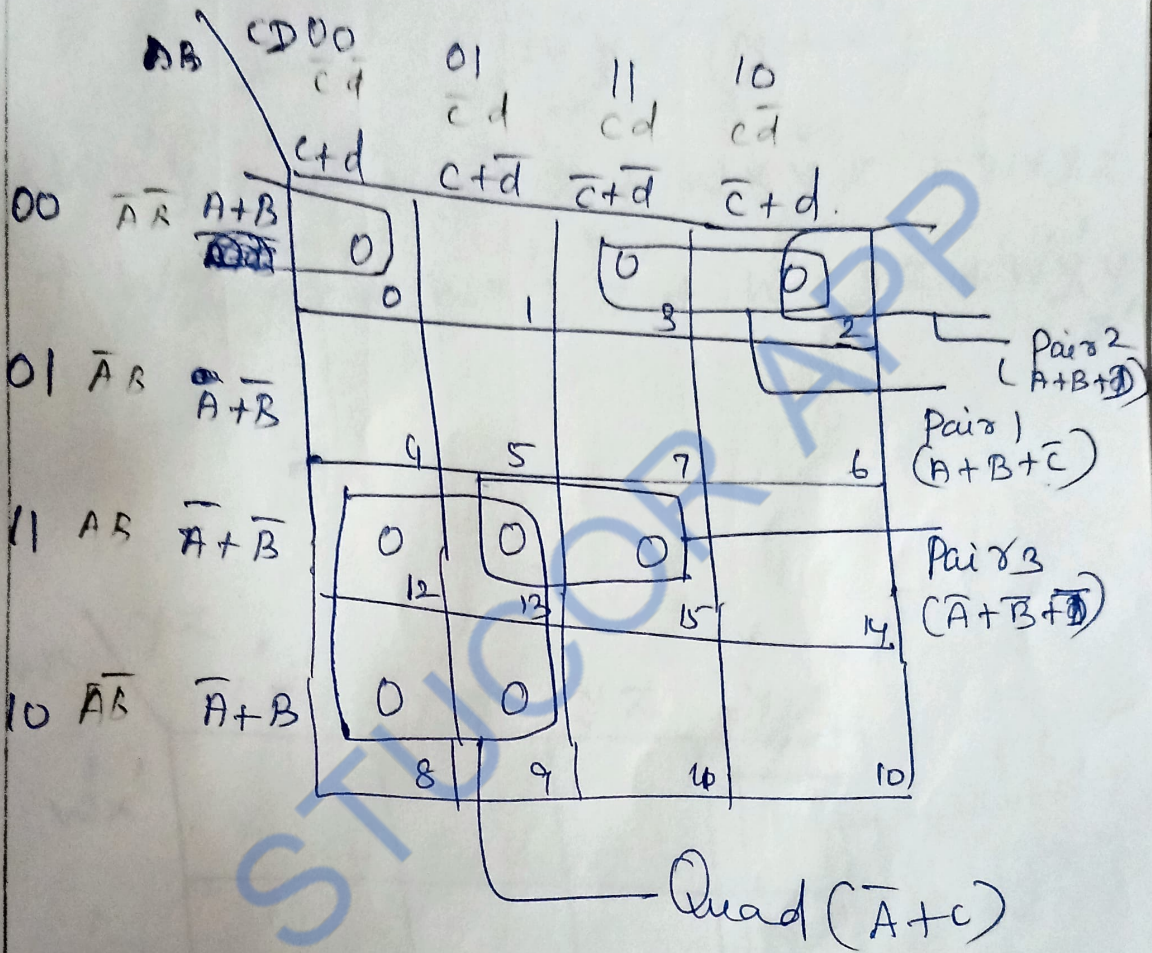

$$Y = (A+B+D) \cdot (A+B+C) \cdot (\bar{A}+\bar{B}+D) \cdot (\bar{A}+C)$$

Simplify the boolean for

$$f(w, x, y, z) = wx'y' + wy + w'y z'$$

$$= wx'y'(z+z') + wy(x+x')(z+z') + w'y z'(x+x')$$

$$= wx'y'z' + wx'y'z + wx\bar{y}z + \bar{w}xy z' + wx'y\bar{z} + wx'y z' + \bar{w}x y z' + \bar{w}x y z$$

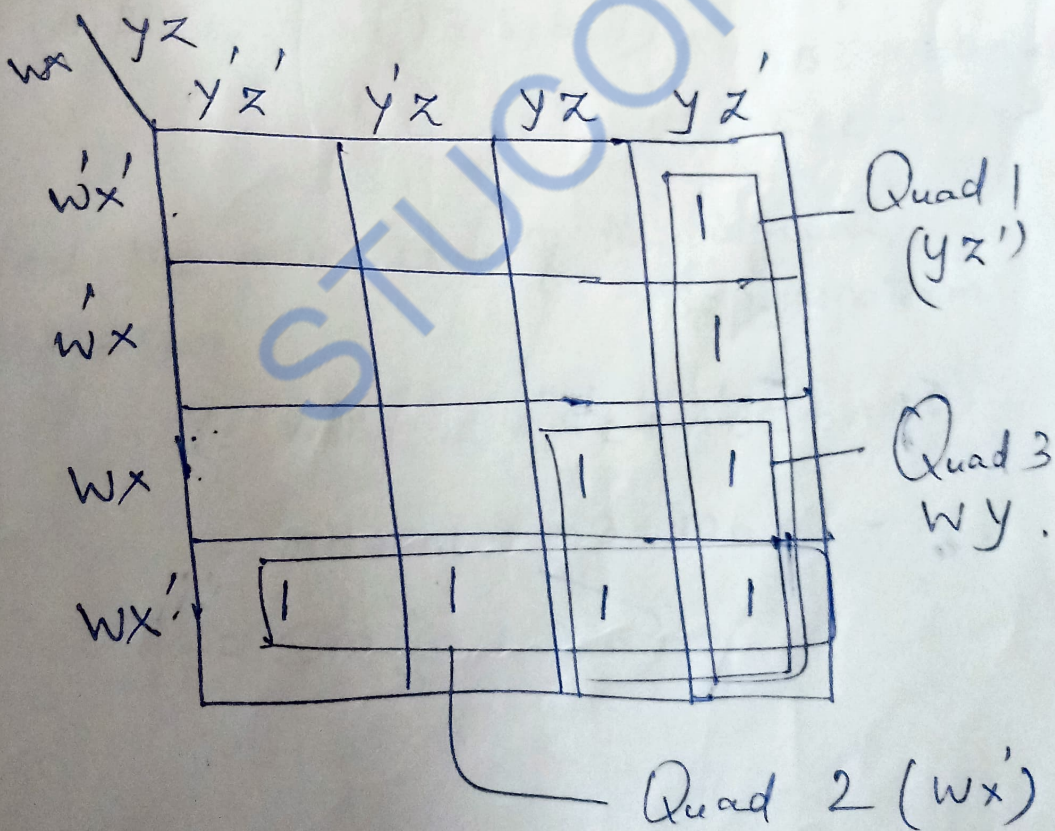

$$f = yz' + wy + wx'$$

$$= yz' + w(y+x')$$

Convert $f(A, B, C) = AC + AB + BC$ to ^{Canonical} Standard SOP form.

$$f(A, B, C) = AC(B + \bar{B}) + AB(C + \bar{C}) + BC(A + \bar{A})$$

$$= ABC + A\bar{B}C + ABC + AB\bar{C} + ABC + \bar{A}BC$$

$$= ABC + ABC + ABC + A\bar{B}C + AB\bar{C} + \bar{A}BC$$

$$= \underbrace{ABC + ABC} + A\bar{B}C + AB\bar{C} + \bar{A}BC$$

$$f(A, B, C) = ABC + A\bar{B}C + AB\bar{C} + \bar{A}BC$$

$$f(A, B, C) = \sum m(3, 5, 6, 7)$$

ABC	$- 7$
$A\bar{B}C$	$- 5$
$AB\bar{C}$	$- 6$
$\bar{A}BC$	$- 3$

Find the min terms of the logical expression.
Sop-Minterm

$$Y = A'B'C' + A'B'C + A'BC + ABC'$$

$$= m_0 + m_1 + m_3 + m_6$$

$$Y = \sum m(0, 1, 3, 6)$$

Convert the given expression in canonical POS form.

$$Y = (A+B)(B+C)(A+C)$$

$$Y = (A+B+(C \cdot C'))(B+C+(A \cdot A'))(A+C+(B \cdot B'))$$

$$= (A+B+C)(A+B+C')(A+B+C)(A'+B+C)$$

$$(A+B+C)(A+B'+C)$$

$$= (A+B+C)(A+B+C)(A+B+C)(A+B+C')$$

$$(A'+B+C)(A+B'+C)$$

$$= (A+B+C)(A+B+C') + (A'+B+C)(A+B'+C)$$

$$Y = \Pi M(0, 1, 2, 4)$$

$$A+B+C = 000 = 0$$

$$A+B+C' = 001 = 1$$

$$A'+B+C = 100 = 4$$

$$A+B'+C = 010 = 2$$

Write the max term corresponding to the logical expression.

$$Y = (A+B+C')(A+B'+C')(A'+B'+C)$$

$$= M_1 \cdot M_3 \cdot M_6$$

$$Y = \Pi M(1, 3, 6)$$

Steps for NAND and NOR logic.

1. Draw the logic circuit with AND/OR.
2. For NAND logic - Add bubble at the o/p of AND
Add bubble at the i/p of OR
3. For NOR logic - Add bubble at the o/p of OR
Add bubble at the i/p of AND.
4. Add NOT gate (Inverter) on the line where bubble is added
5. Eliminate double inversion.

Given the logical equation $Y = (A + \bar{B}C)(C + AB)$

- (i) Design a circuit using AND and OR gates to realize the above function.
- (ii) Realize the above function using only NAND and only NOR gates after simplification.

$$(i) \quad Y = (A + \bar{B}C) \cdot (C + AB)$$

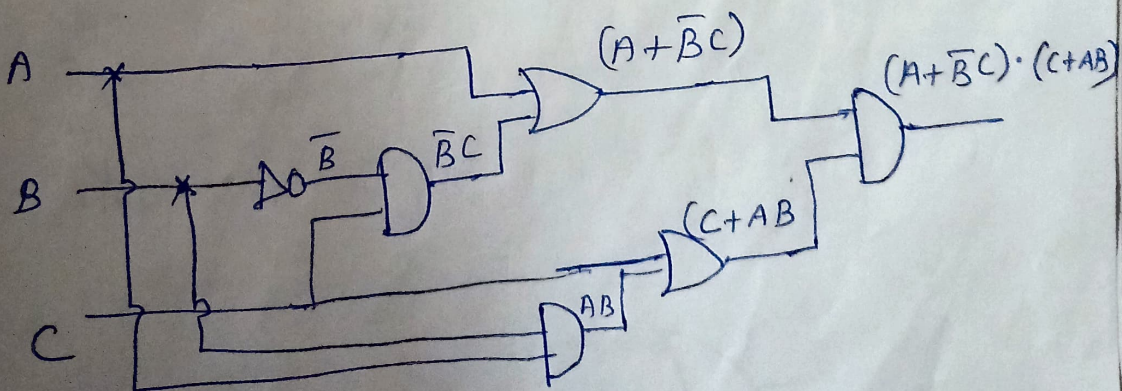

(ii) Simplification

$$Y = (A + \bar{B}C)(C + AB)$$

$$= AC + \underbrace{AAB}_{A} + \underbrace{\bar{B}CC}_{C} + \underbrace{AB\bar{B}C}_{0}$$

$$\left[\begin{array}{l} A \cdot A = A \\ C \cdot C = C \\ B \cdot \bar{B} = 0 \end{array} \right]$$

$$Y = AC + AB + \bar{B}C$$

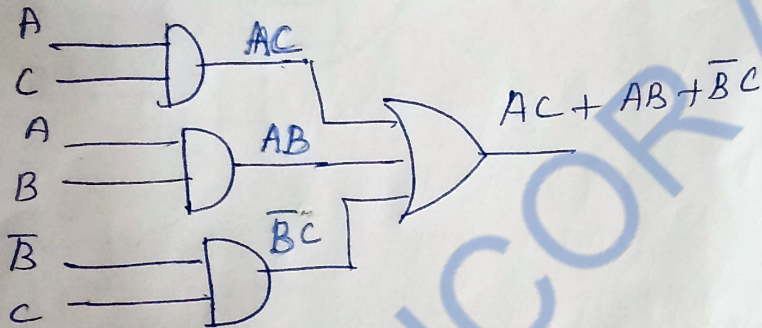
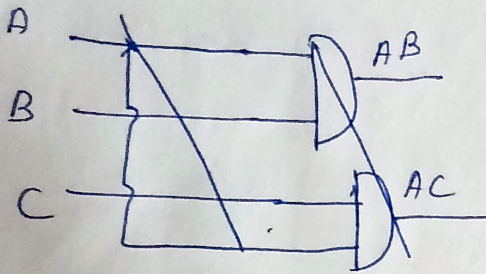

NAND logic Step-1.

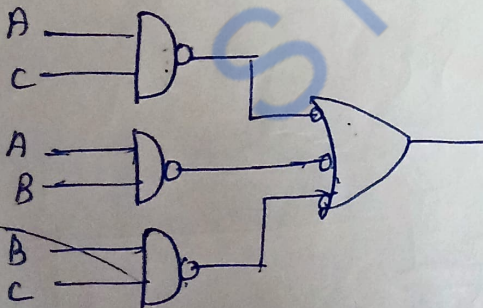

Step-2.

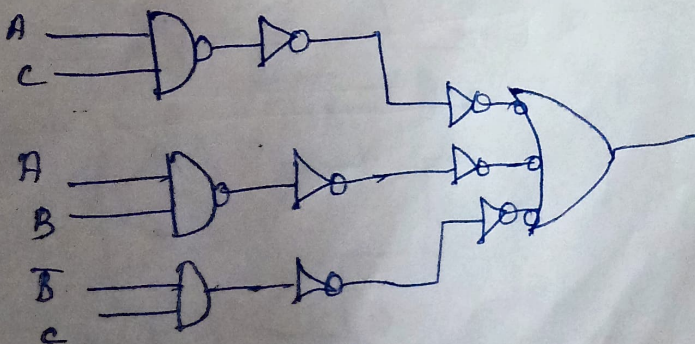

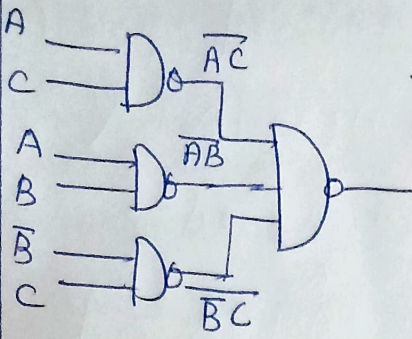

$$\overline{AC \cdot AB \cdot \overline{BC}}$$

$$= \overline{AC} + \overline{AB} + \overline{\overline{BC}}$$

De Morgan's Theorem

$$= AC + AB + \overline{BC}$$

NOR logic

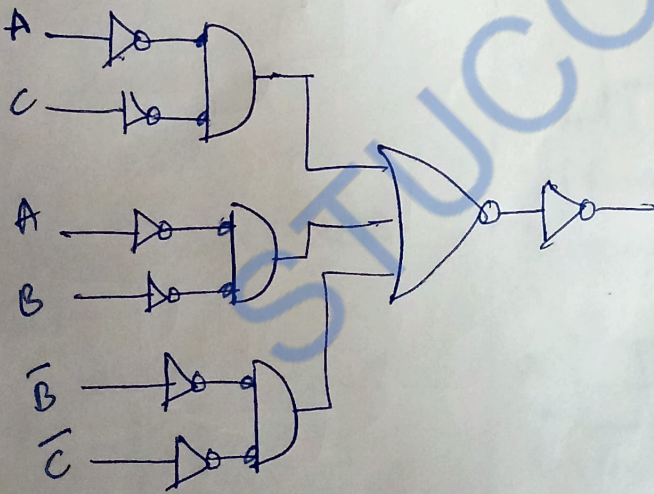
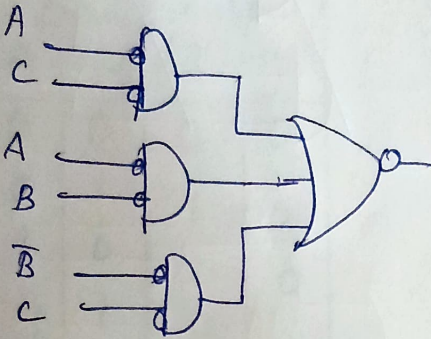

$$\overline{A+C} = \overline{A} \cdot \overline{C} = AC$$

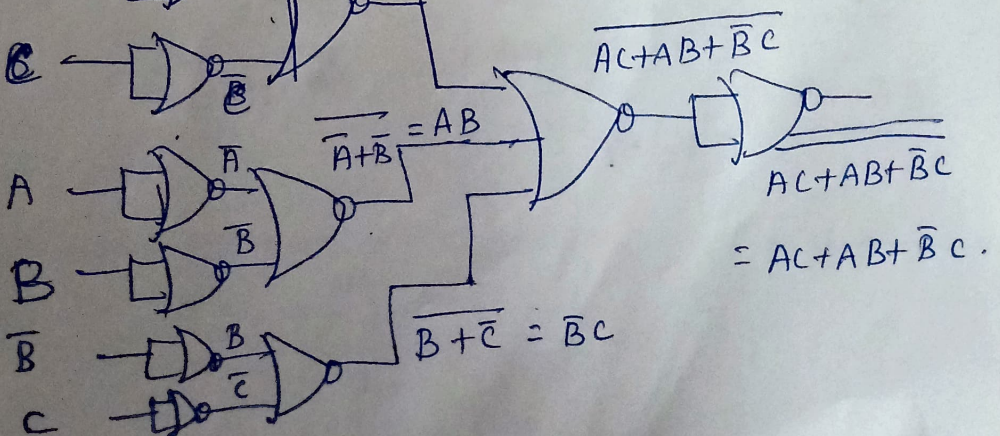

Combinational Logic Circuit

Half adder

- Add 2 single bit binary numbers.

Inputs: A, B

Outputs: Sum (S)
Carry (cy)

Truth Table:

Inputs		Outputs	
A	B	S	cy
0	0	0	0
0	1	1	0
1	0	1	0
1	1	0	1

Sum

	0	1
0	0	1
1	1	0

$$\text{Sum} = \bar{A}B + A\bar{B} = A \oplus B$$

Carry

	0	1
0	0	0
1	0	1

$$\text{Carry} = AB$$

Logic diagram

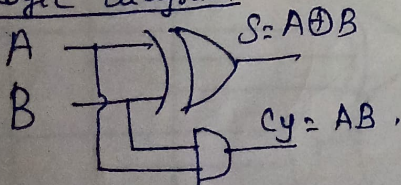

Half Subtractor

- Subtract 2 single bit binary numbers.

Inputs: A, B

Outputs: Difference (D)
Borrow (Br)

Truth Table

Inputs		Outputs	
A	B	D	Br
0	0	0	0
0	1	1	1
1	0	1	0
1	1	0	0

Difference

	0	1
0	0	1
1	1	0

$$\text{Difference (D)} = \bar{A}B + A\bar{B} = A \oplus B$$

Borrow

	0	1
0	0	0
1	0	1

$$\text{Borrow (Br)} = \bar{A}B$$

Logic diagram

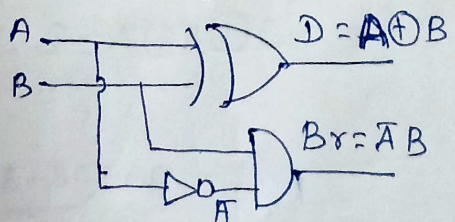

Full adder

- Add 3 Single bit binary numbers
- Inputs - A, B, C.
- Outputs - Sum (S), and Carry (cy).

Truth Table.

Inputs			Outputs	
A	B	C	S	cy
0	0	0	0	0
0	0	1	1	0
0	1	0	1	0
0	1	1	0	1
1	0	0	1	0
1	0	1	0	1
1	1	0	0	1
1	1	1	1	1

Carry.

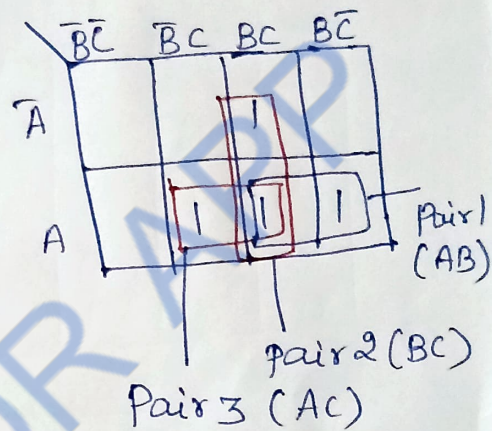

$$\text{Carry} = AB + BC + AC.$$

Sum

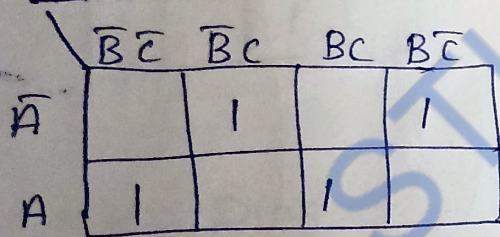

$$\begin{aligned} \text{Sum} &= \bar{A}\bar{B}C + \bar{A}B\bar{C} + A\bar{B}\bar{C} + ABC \\ &= \bar{A}\bar{B}C + ABC + \bar{A}B\bar{C} + A\bar{B}\bar{C} \\ &= (\bar{A}\bar{B} + AB) \cdot C + (\bar{A}B + A\bar{B}) \cdot \bar{C} \\ &= (\overline{A \oplus B}) \cdot C + (A \oplus B) \cdot \bar{C} \end{aligned}$$

$$S = A \oplus B \oplus C$$

Logic diagram

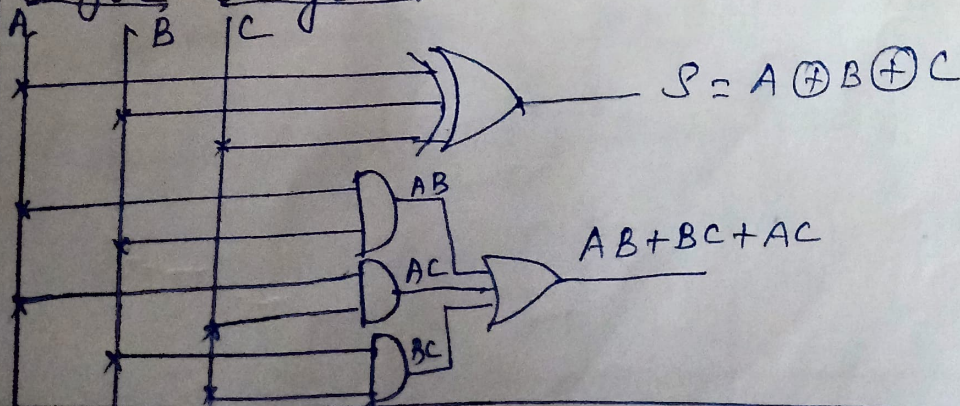

Full Subtractor

- Subtract 3 Single bit binary numbers
- Inputs - A, B, C
- Outputs - Difference (D), Borrow (B_r).

Truth Table:-

Inputs			Outputs	
A	B	C	D	B _r
0	0	0	0	0
0	0	1	1	1
0	1	0	1	1
0	1	1	0	1
1	0	0	1	0
1	0	1	0	0
1	1	0	0	0
1	1	1	1	1

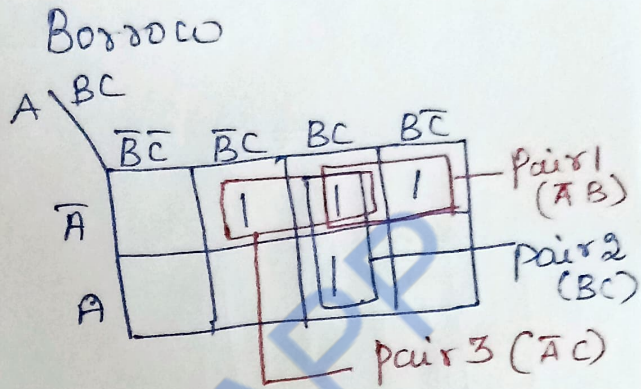

$$B_r = \bar{A}B + BC + \bar{A}C$$

Difference

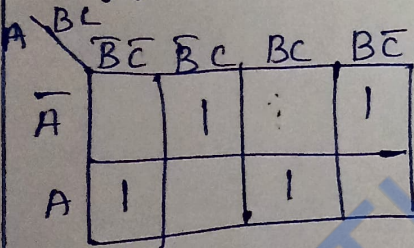

$$\begin{aligned} D &= \bar{A}\bar{B}C + \bar{A}B\bar{C} + A\bar{B}\bar{C} + ABC \\ &= \bar{A}\bar{B}C + ABC + \bar{A}B\bar{C} + A\bar{B}\bar{C} \\ &= C(\bar{A}\bar{B} + AB) + \bar{C}(\bar{A}B + A\bar{B}) \\ &= C(\overline{A \oplus B}) + \bar{C}(A \oplus B) \end{aligned}$$

$$D = A \oplus B \oplus C$$

Logic Diagram

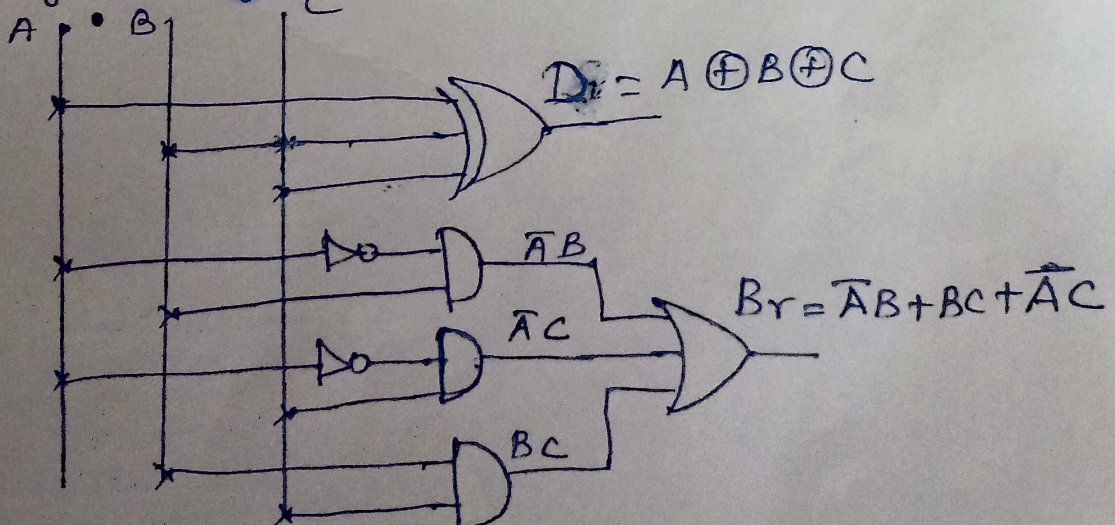

Introduction:

Measurement is an act or the result of quantitative comparison between an unknown magnitude and the predefined standard.

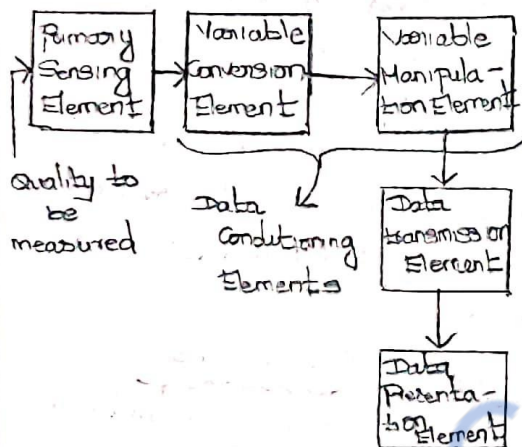
Functional Elements of an Instrument:

Three main functional elements

1. primary sensing element
2. Variable Conversion element
3. Data Presentation element

1. Primary sensing element

The quantity under measurement is made to be in contact with primary sensing element. The primary sensing element is transducers. The transducer converts measurand into an analogous electrical signal.

2. Variable Conversion element

The output of the primary sensing element is the electrical signal

- It may be a voltage, a frequency or some other electrical parameter
- Instrument to perform the desired function, it is necessary to convert this output to some other suitable form.

Ex: If the output is an analog signal form but the next stage of the system accepts input signal only in digital form. ∴ we have to use analog to digital converter in this system.

Variable manipulation element:

The main function is to manipulate the signal presented to it but, preserving the original nature of the signal.

Ex: An electronic amplifier circuit accepts a small voltage signal as input and produces as output signal which is also voltage but of greater amplitude. Voltage amplifier acts as a variable manipulation element.

3. Data presentation element

The information about the quantity under measurement has to be conveyed to the

person handling the instrument (or) system for control (or) analysis purposes.

- The information conveyed must be in the form of intelligible form to the person.

- The output or data of the system can be monitored by using visual display devices.

- These devices may be analog or digital like ammeter, digital meter etc.

- In case the data to be recorded, we can use analog or digital recording equipment.

- In industries for control and analysis purpose we can use computers.

Standards of measurement:

- Standard is a physical representation of a unit of measurement.

- A known accurate measure of physical quantity is termed as standard. These standards are used to determine the values of other physical quantities by the comparison method.

standards are classified into four categories as

1. International standards
2. Primary standards
3. Secondary standards
4. Working standards.

1. International standards

- They are periodically evaluated and checked by absolute measurements in terms of fundamental units of physics.

- These international standards are not available to ordinary users for measurements and calibrations.

2. Primary standards

- Function of primary standards is the calibration and verification of secondary standards.

- They are not available for outside usage other than the National laboratory.

- High accuracy that can be used as ultimate reference standards.

3. Secondary standards

- Secondary standards are maintained by the particular industry to which they belong.

- Each industry has its own secondary standard.

- Each laboratory periodically sends its secondary standard to the National standard laboratory for calibration and comparison against primary standard.

Working standards

- These standards are used to check and calibrate laboratory instruments for accuracy and performance.

Ex: Manufacturers of electronic components such as capacitors, resistors etc, use a standard called working standard for checking the component values being manufactured.

(i.e) standard resistor for checking of resistance value manufactured.

Calibration

Calibration is the result of quantitative comparison between a known standard and the output of the measuring system measuring the same quantity.

Types of Calibration

1. Primary calibration
2. Secondary calibration
3. Direct calibration

4. Indirect calibration
5. Routine calibration

1. Primary calibration

- When a device/meter is calibrated against primary standards, the procedure is termed primary calibration.

- After primary calibration, the device is employed as a secondary calibration device.

2. Secondary calibration

- When a secondary calibration device is used for further calibrating another device of lesser accuracy, then the procedure is termed as secondary calibration.

3. Direct calibration

- Direct calibration with a known input source is of the same order of accuracy as primary calibration.

- ∴ devices calibrated directly are also used as secondary calibration devices.

4. Indirect calibration

- Indirect calibration is based on the equivalence of two different devices that can be employed for measuring a certain physical quantity.

- To predict the performance of one meter on the basis of an experimental study of another.

Routine Calibration:

Routine calibration is the procedure of periodically checking the accuracy and proper functioning of an instrument with standards.

Classification of Analog Instruments

1. Indicating Instruments.
2. Recording Instruments
3. Integrating Instruments.

1. Indicating Instruments

Instrument which indicate the magnitude of a quantity being measured by using a dial and pointer arrangement. Eg: voltmeter, Ammeter

2. Recording Instruments:

Instrument which give a continuous record of the quantity being measured over a specific period.

Eg:- Drawing a graph using a pen and a sheet of paper.

3. Integrating Instruments:

Instrument which totalize the

events over a specified period of time.

Eg: house hold Energy meter.
($E = P \times t$)

Torque in Indicating Instruments

1. Deflecting force
2. Controlling force
3. Damping force

1. Deflecting force

The deflecting force is the operating force required for moving the pointer from its zero position.

2. Controlling force:

Controlling force is the opposing force required by an indicating instrument in order that the current to be measured produces deflection of the pointer proportional to its magnitude.

3. Damping force:

Damping force is provided in order to bring the pointer to rest within short time.

The quickness with which the moving system settles to the final steady position without overshooting depends on relative damping.

Permanent Magnet Moving Coil (PMMC) Instruments

PMMC Instruments are used to give accurate reading in DC measurements.

Basic principle:

- It works on motoring principle
 - When a current carrying conductor is placed in a magnetic field produced by a permanent magnet, the coil experiences a force and hence moves.

- Coil is moving and magnet is permanent this instrument called permanent magnet moving coil.
 - Force experienced by the coil proportional to the current passing through the coil.

Construction:

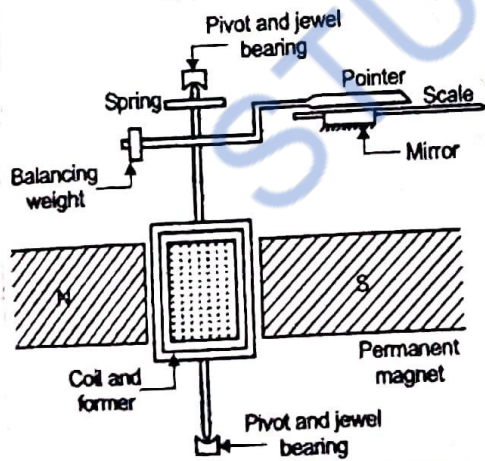

- Consist of a moving coil which is either rectangular or circular in shape, which has number of turns of fine wire

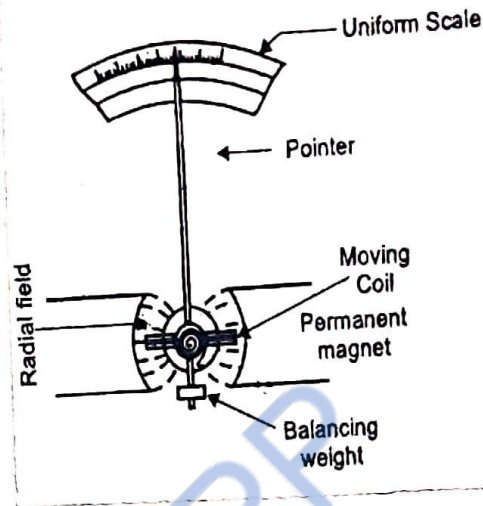

- Coil suspended so that it is free to turn about its vertical axis.
 - Coil is placed in uniform magnetic field of a permanent magnet.
 - Iron case is spherical if the coil is circular.
 - Iron case is cylindrical if the coil is rectangular.
 - Due to Iron case deflection torque increases.
 - Controlling torque is provided by spring control.
 - Damping torque provided by movement of aluminium former in the magnetic field.
 - Pointer is connected to the spindle moves over a uniformly scale
 - Pointer is light weight one
 - Total weight of instrument counter balanced by balancing weight.

- Mirror is placed below the pointer to get an accurate reading without parallax error.
- In PMMC deflection of the pointer is directly proportional to the current passing through the coil.

Torque Equation:

Deflecting torque is derived from basic equation of electromagnetic torque

$$T_d = NBAI \quad \text{--- (1)}$$

where

T_d - Deflecting torque in N-m

N - Number of turns of the coil

A - Effective coil area in m^2

I - Current passing through moving coil in amperes

B - Flux density in air gap in wb/m^2

G - NBA - Constant.

$$T_d = GI \quad \text{--- (2)}$$

Controlling torque is provided by the spring and is proportional to the angular deflection of the pointer

$$T_c \propto \theta$$

$$T_c = K_s \theta \quad \text{--- (3)}$$

where

T_c = Controlling torque (N-m)

K_s - Spring constant

θ - Angular deflection in degree
At final steady deflection

$$T_c = T_d$$

$$K_s \theta = GI$$

$$\theta = \left(\frac{G}{K_s} \right) I$$

$$\theta \propto I$$

Deflection of pointer is directly proportional to the current to be measured.

Errors in PMMC:

- Weakening of permanent magnet, springs due to ageing.

Advantages:

- Uniform scale
- High sensitivity
- Low power consumption

Disadvantages:

- Used only for DC measurement
- PMMC cost is higher than moving iron instrument.

Moving Iron (MI) Instruments

Moving Iron most commonly used laboratory Instruments.

classified into

1. Moving Iron Attraction type
2. Moving Iron Repulsion type

1. Moving Iron Attraction type Instrument:

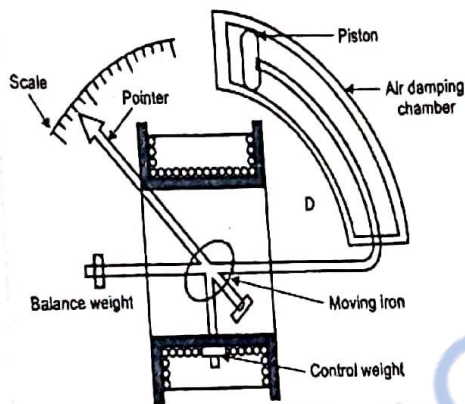

- Moving Iron is a flat disc
- when the current to be measured flows through the coil, magnetic field is produced which attracts the moving iron towards it, this makes the pointer to move.
- Controlling torque is provided by springs.
- Air friction damping is provided with the help of light

2. Moving Iron repulsion type Instrument

- It consist of two vanes inside the coil. one vane is fixed other

is movable.

- When the current to be measured flows through the coil, both the vanes get magnetised, a force of repulsion exists between the two vanes which results in movement of the moving vane and thus the pointer moves.

Two types of Repulsion types

(1) Radial vane type:

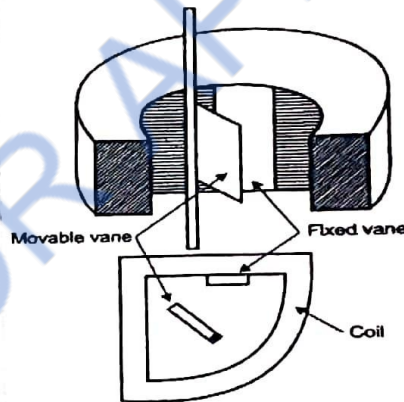

- Fixed vane is attached to the coil and the movable vane is attached to the spindle of the instrument which in turn is attached to the pointer.

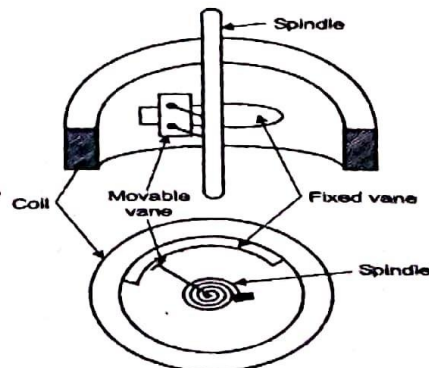

- Fixed and moving vanes are sections of coaxial cylinders.
- Controlling torque provided by springs.
- Damping torque is provided by air friction damping.
- MI type used for both AC and DC measurements.
- Because, whatever may be direction of the current through the coil, the iron vanes get magnetised and there will be a force of attraction in attraction type and there will be a force of repulsion in the repulsion type instrument.

Torque Equation

Small increment in the current dI supplied to the coil, there will be small deflection $d\theta$ and some mechanical work will be done.

If T_d is deflection torque then
Mechanical work done = $T_d \cdot d\theta$

Let

- I - Initial current in A
- L - Instrument inductance in H
- θ - Deflection in radians
- dI - Increase in current in A
- $d\theta$ - Change in deflection in radians

dL = change in Inductance in H.

If current increases by dI , deflection changes by $d\theta$, which changes Inductance dL .

$$e = \frac{d}{dt}(LI)$$

where 'e' is applied voltage

$$e = I \frac{dL}{dt} + L \frac{dI}{dt}$$

Electrical energy supplied given by

$$e I dt = \left[I \frac{dL}{dt} + L \frac{dI}{dt} \right] I dt$$

$$e I dt = I^2 dL + L I dI$$

From principle of Conservation of energy

Electrical energy supplied = change in stored energy + Mechanical work done

$$I^2 dL + L I dI = L I dI + \frac{1}{2} I^2 dL + T_d d\theta$$

$$T_d d\theta = \frac{1}{2} I^2 dL$$

$$T_d = \frac{1}{2} I^2 \frac{dL}{d\theta} \quad \text{--- (1)}$$

Controlling torque

$$T_c = K \theta \quad \text{--- (2)}$$

At final steady state

$$T_c = T_d$$

$$K_s \theta = \frac{1}{2} I^2 \frac{dL}{d\theta}$$

$$\theta = \frac{1}{2} \frac{I^2}{K_s} \frac{dL}{d\theta}$$

$$\theta \propto I^2$$

Deflection of pointer \propto square of the current to be measured

- Deflection torque unidirectional whatever may be the polarity of the current.
- MI used for both AC and DC

Advantages:

- used for both AC and DC measurement.
- Highly accurate.
- Simple in construction

Disadvantages:

- scale is not uniform

Induction type energy meter

used to measure energy which is the total power consumed over a specific interval of time.
unit kWh (or) unit

$$\text{Energy} = \text{power} \times \text{time}$$

Basic principle

- operation based on passage of alternating current through two coils (current coil and pressure coil)
- coil produces rotating magnetic field which interacts with a disc and makes the disc rotate
- current coil carries line current which is in phase with supply voltage.
- pressure coil are highly inductive hence current lags the supply voltage by 90°
- Therefore phase difference 90° exist between the fluxes developed by two coils.
- Due to this rotating field develops which interacts with disc to rotate.

Construction Details

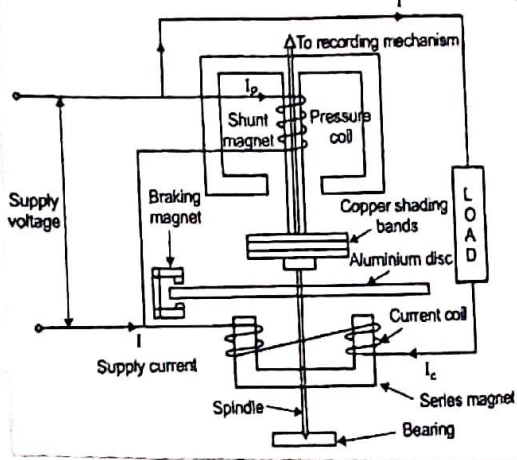

(I) Driving system

- It consists of two electromagnets, whose core is made up of silicon steel.
- Current coil which is excited by load current.
- Pressure coil which is connected across the supply.
- shading band on central limb to bring the flux produced by the shunt magnet is exactly quadrature with applied voltage.

(II) Moving system

- consists of aluminium disc mounted on shaft.
- Disc is placed between series and shunt magnet.

- Moving system connected to bearing.

(III) Braking system

- consists of permanent magnet, near the edge of aluminium disc.
- Aluminium disc moves in the field of the magnet.
- By adjusting the position of permanent magnet, braking torque adjusted.

(IV) Registering / Counting mechanism

- Its function is to record no. of revolutions made by the moving system.
- pointer rotates on round dial which are marked with ten equal divisions.

operation:

- Current coil carries the load current. Its magnetic field is in phase with line current.
- Pressure coil carries current proportional to the supply voltage. Magnetic field by pressure coil lags 90° behind the supply voltage.
- phase difference exists b/w two flux by two coils.

- Due to this rotating magnetic field develops which interacts with the disc to rotate.
- Braking magnet produces braking torque on the disc.
- The spindle is geared to the recording mechanism so that electrical energy consumed in the circuit directly given in kWh (kilowatt hour)

Advantages:

- simple operation
- cheap in cost.

Instrument transformers:

- Instrument transformers are used in AC system for measurement of electrical quantities (i.e) voltage, current.
- Basic function of instrument transformers is to step down the AC system voltage and current.
- The voltage and current level of power system is very high. It is very difficult and costly to design the measuring instruments for measurement of such high level voltage and current.

- Generally measuring instruments are designed for 5A and 110V.
- Measurement of such large electrical quantities can be made possible by using instrument transformer with these small rating measuring instruments.

Types of Instrument transformers

- (1) Current transformer (C.T)
- (2) Potential transformer (P.T)

(1) Current transformer (C.T)

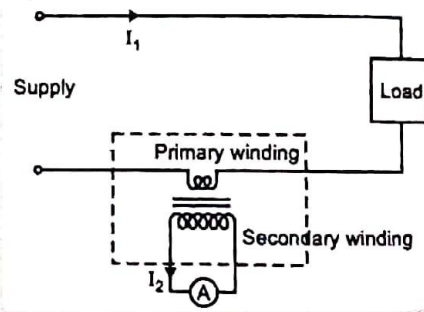

- It is used to step down the current of power system to a lower level to make it feasible to be measured by small rating Ammeter (i.e 5A Ammeter)
- Primary of C.T having very few turns.
- Primary connected to power circuit.

- It is also called series transformer.
- Secondary having large no. of turns.
- Secondary is connected to Ammeter.
- As Ammeter having very small resistance.
- Secondary of C.T operates almost short circuit condition
- one terminal secondary is earthed.
- Before disconnecting Ammeter secondary is short circuit through switch 'S'.

(2) potential transformer: (P.T)

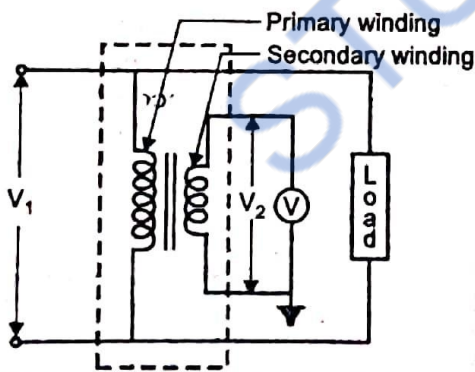

- Primary (P.T) having large no. of turns.
- It is also called parallel transformer.

- Secondary of P.T having few turns and connected directly to a voltmeter.
- As voltmeter having large resistance
- Hence secondary of P.T operates almost in open circuit condition.
- one terminal of secondary of P.T is earthed, which assures the safety.

Measurement of Power using C.T and P.T

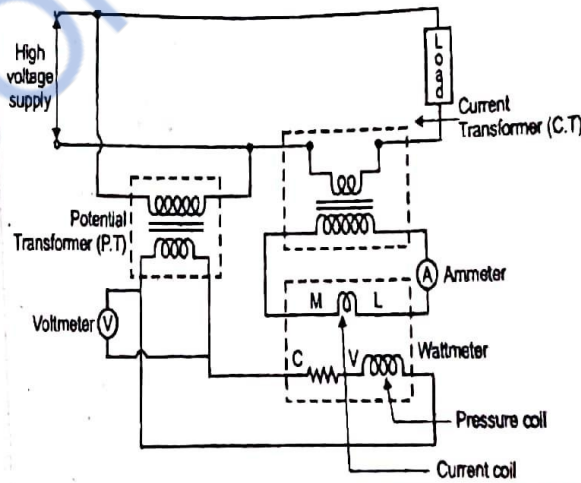

- The primary winding of C.T is connected in series with the load. Secondary is connected in series with an ammeter and the current coil of a wattmeter.

- The primary winding of P.T is connected across the supply voltage and the secondary is connected across voltmeter and the pressure coil of the wattmeter
- The circuit connections of single phase energy meter is exactly similar to the connections of wattmeter along with C.T and P.T for power measurement.
- The only difference in that, the pressure coil of wattmeter is replaced by pressure coil of energy meter and the current coil of wattmeter is replaced by current coil of energy meter.

Advantages:

- High voltage and high current can be measured using low range voltmeter and ammeter along with the instrument transformer.
- The rating of low range meter can be fixed irrespective of the value of high voltage or current to be measured.
- It isolate the high voltage and high current from measuring instruments.

Disadvantages:

- It can be used only for AC circuits and not for DC circuits.

Measurement of three phase power

1. Three wattmeter method (Using 3 - single phase wattmeter)
2. Two wattmeter method (Using 2 - single phase wattmeter)
3. By using three phase wattmeter

1. Three wattmeter method

- Measurement of power in 3 phase 4-wire system.
- This method consists of 3 wattmeter and hence the name 3 wattmeter method, and combination of a pressure coil and current coil is called element

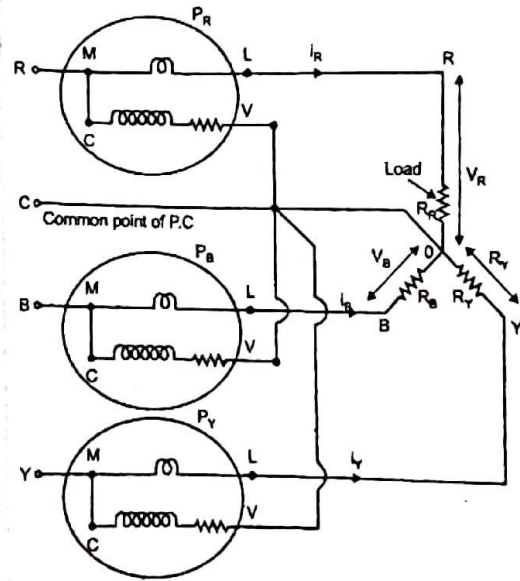

- 3 phase 4 wire system, the common point 'c' of pressure coils and neutral point 'o' of the load coincides

- Voltage across pressure coil of wattmeter is equal to phase voltage across the load

- (1.e)
 Voltage across pressure coil wattmeter 1 = V_R
 Voltage across pressure coil wattmeter 2 = V_Y
 Voltage across pressure coil wattmeter 3 = V_B

where

- V_R - voltage across R-phase of the load
- V_Y - voltage across Y-phase of the load
- V_B - voltage across Z-phase of the load
- I_R - current flowing through R-phase of load
- I_Y - current flowing through Y phase of load
- I_B - current flowing through B phase of load

Instantaneous power consumed by load

$$= V_R I_R + V_Y I_Y + V_B I_B$$

As voltage across the pressure coil of each wattmeter = voltage per phase of the load

Current flowing through current coil of each wattmeter = current flowing through each phase of load.

(1.e) $P = P_R + P_Y + P_B$

$$P = V_R I_R + V_Y I_Y + V_B I_B$$

2. Two wattmeter method

- Measurement of power for 3 phase three wire system.
- For 3 wire system requires three wattmeter. we coincide the common point pressure coil of two wattmeters with the third phase
- this method also called 2 element method

Two cases

1. Star Connected load
2. Delta Connected load

Case (1) star connection

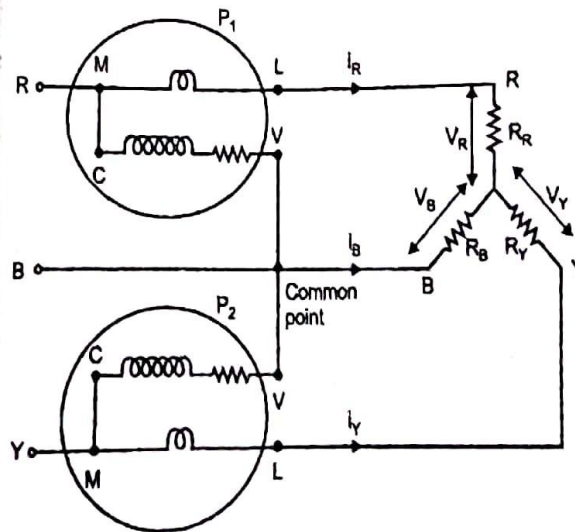

i_R - Current flowing through R-phase load

i_Y - Current flowing through Y-phase load

i_B - Current flowing through B-phase load

V_R - Voltage across R-phase

V_Y - voltage across Y-phase

V_B - Voltage across B-phase

Reading of wattmeter 1

$$P_1 = i_R (V_R - V_B) \quad \text{--- (1)}$$

Reading of wattmeter 2

$$P_2 = i_Y (V_Y - V_B) \quad \text{--- (2)}$$

Sum of Reading of two wattmeters

$$= P_1 + P_2$$

$$= i_R (V_R - V_B) + i_Y (V_Y - V_B)$$

$$= i_R V_R - i_R V_B + i_Y V_Y - i_Y V_B$$

$$P_1 + P_2 = V_R i_R + V_Y i_Y - V_B (i_R + i_Y) \quad \text{--- (3)}$$

Load is connected using KCL

$$i_R + i_Y + i_B = 0$$

$$i_R + i_Y = -i_B \quad \text{--- (4)}$$

Sub (4) in (3) we get

$$P_1 + P_2 = V_R i_R + V_Y i_Y - V_B (-i_B)$$

$$P_1 + P_2 = V_R i_R + V_Y i_Y + V_B i_B$$

Sum of two readings of two wattmeters = total power consumed by the load

Case 2 Delta Connection

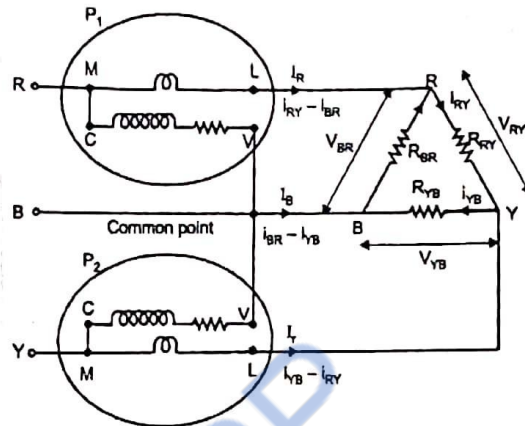

Reading of wattmeter 1

$$P_1 = -V_{BR} (i_{RY} - i_{BR}) \quad \text{--- (1)}$$

Reading of wattmeter 2

$$P_2 = V_{YB} (i_{YB} - i_{RY}) \quad \text{--- (2)}$$

Sum of two wattmeter given by

$$P_1 + P_2 = -V_{BR} (i_{RY} - i_{BR}) + V_{YB} (i_{YB} - i_{RY})$$

$$P_1 + P_2 = -V_{BR} i_{RY} + V_{BR} i_{BR} +$$

$$V_{YB} i_{YB} - V_{YB} i_{RY}$$

$$P_1 + P_2 = V_{BR} i_{BR} + V_{YB} i_{YB} -$$

$$i_{RY} (V_{YB} + V_{BR}) \quad \text{--- (3)}$$

Apply KVL $V_{RY} + V_{YB} + V_{BR} = 0$

$$V_{YB} + V_{BR} = -V_{RY} \quad \text{--- (4)}$$

Sub (4) in (3)

$$P_1 + P_2 = V_{BR} i_{BR} + V_{YB} i_{YB} -$$

$$i_{RY} (-V_{RY})$$

$$P_1 + P_2 = V_{BR} i_{BR} + V_{YB} i_{YB} +$$

$$V_{RY} i_{RY}$$

Recharge

$$P_1 + P_2 = V_R i_{R_Y} + V_{YB} i_{YB} + V_{BR} i_{BR}$$

Sum of two wattmeter is equal to the total power consumed by the load

(3) Three phase wattmeter

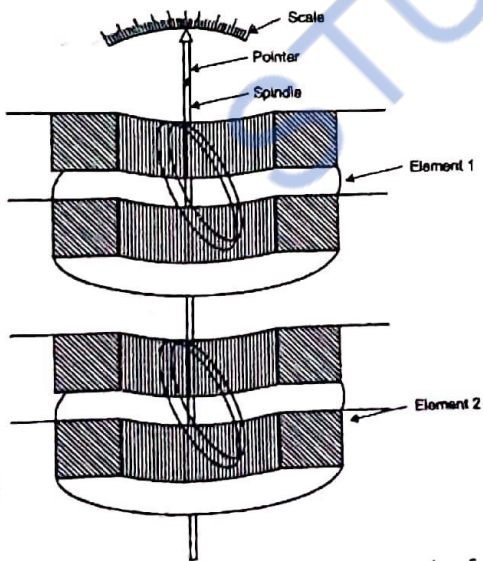
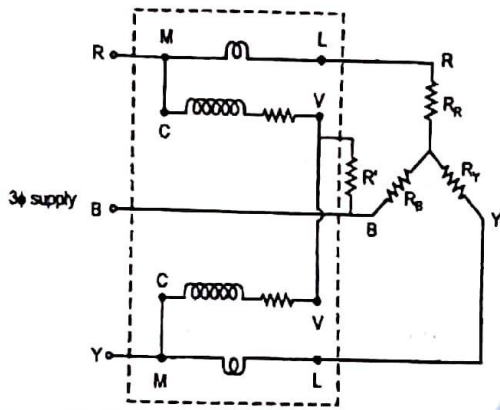

- It consists of two separate wattmeter mounted together in one case with the two moving coils mounted on the same spindle.

- A current coil together with its pressure coil is known as element

- The connection of two element of a 3φ wattmeter is same as that of the two wattmeter method using two single phase wattmeters.

Electrodynamometer wattmeter (1φ power measurement)

The construction of electrodynamic wattmeter is similar to that of ammeter and voltmeter.

- It consist of fixed coil which is connected in series with the load and it carries the current through the load

- Here the fixed coil is also called field coil (∝) current coil.

- The moving coil is connected across the load and it carries the current proportional to the voltage across the load

- Hence moving coil is also called potential coil (∝) pressure coil (∝) voltage coil

Construction and operation

- Used for 1 ϕ power measurement

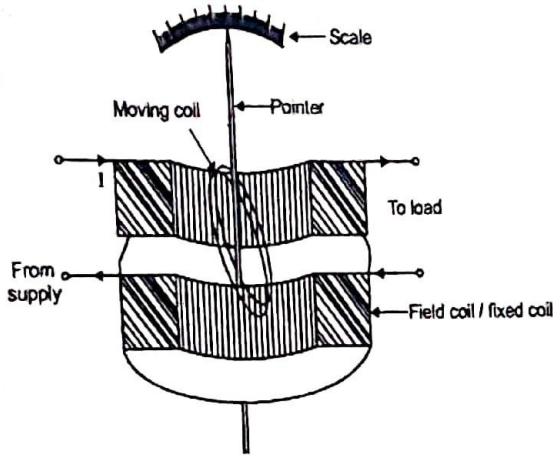
Fixed coil:

- The fixed coils are wound with heavy wire with less number of turns in order to have low resistance and hence low voltage drop across the meter.
- The maximum current range of wattmeter is 20A

Moving Coil:

- The moving coil also called pressure coil is made of thin wire but has more number of turns in order to have high resistance.
- The voltage rating of the wattmeter is limited to 100V.

Control torque:

Control torque is provided by springs, as it is an electrodynamic type instrument.

Damping

Air friction damping is used.

Pointer and scale

This type of instrument has mirror type scales and knife edge pointers to avoid parallax error while reading.

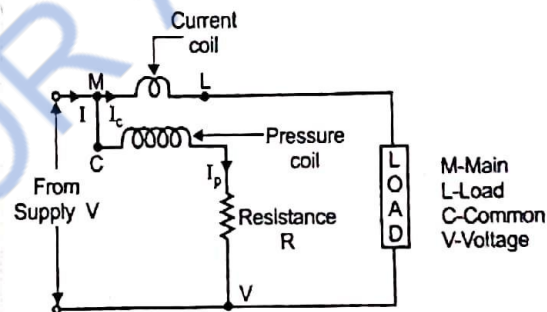
Errors in Electrodynamic type wattmeter

1. Error due to pressure coil inductance and it can be avoided by compensation.
2. Error due to pressure coil capacitance.
3. Error due to wrong connection of current coil and pressure coil.
4. Error caused by vibration of moving system.
5. Temperature error.

Digital Storage Oscilloscope

Digital storage oscilloscope stores a signal by converting successive samples to binary numbers, which are stored in a digital memory and used to recreate a composite waveform in much the same manner as the sampling oscilloscope display is created.

Below figure shows the block diagram of a digital storage oscilloscope.

- The input is amplified and attenuated with input amplifier as in any oscilloscope.
- Then, the samples are taken by a sample-and-hold circuit that is connected to the input signal for a very short period of time compared to the length of one cycle.
- The sample and hold circuit effectively snaps a picture of the voltage level.
- The output of the sample and hold circuit is connected to an analog to digital converter, where the analog voltage level is converted to a digital number and stored in memory.

- When enough samples have been taken, the stored digital numbers are successively converted into analog values by a digital to analog converter, and are then sent to the vertical deflection circuit as the trace is swept horizontally in synchronism.

- This digital to analog conversion process is repeated continuously maintaining the trace on the screen as long as desired, through the vertical deflection amplifier.

Advantages:

- Infinite storage time
- Easy to operate
- Signal processing is possible
- It is capable of displaying X-Y plots, P-V diagrams and B-H curve
- A number of traces depending on the memory size can be stored and recalled.

Application:

- It can be used to measure AC as well as DC voltages and currents, frequency, time period.
- It can also be used to analyze TV waveforms.
- It can also be used to check faulty components in various circuits.

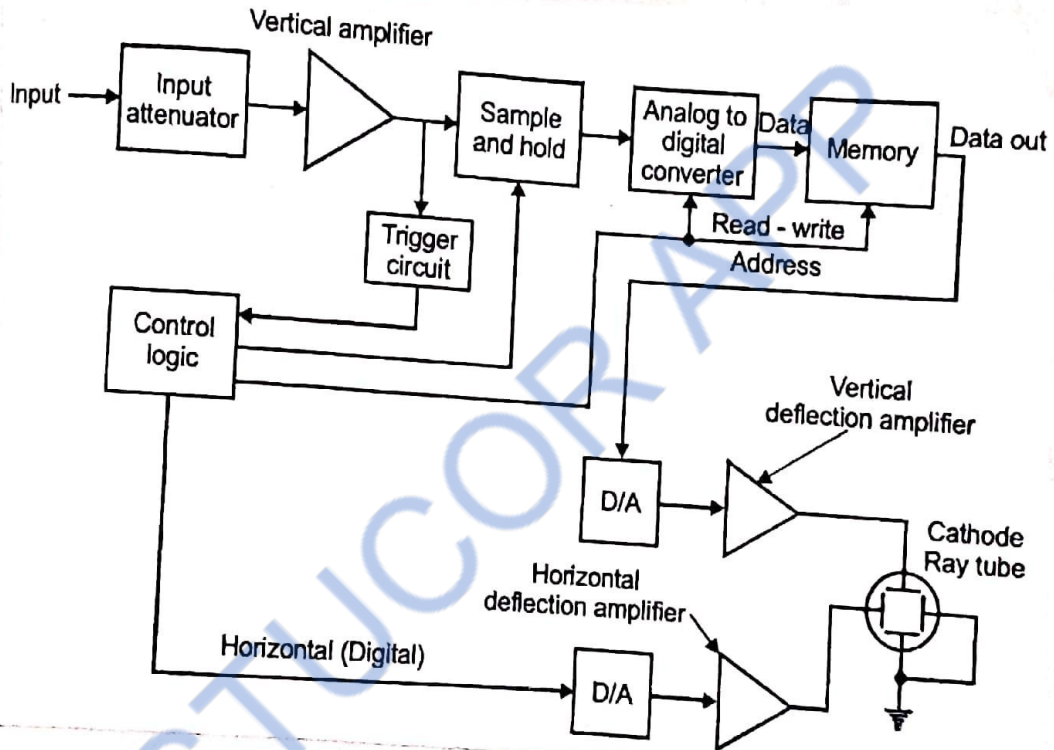

Data Acquisition System

It consists of individual sensors with the necessary signal conditioning, data conversion, data processing, multiplexing, data handling and associated transmission, storage and display system.

- Analog data is generally acquired and converted into digital form for the purpose of processing, transmission, display and storage.
- To increase the speed with which information is accurately converted, sample and hold (S/H) circuits are used.

Data Acquisition with example

(*) The process of digitizing data from the world around us, so it can be displayed, analyzed, and stored in a computer. A simple example is the process of measuring the temperature in a room as a digital value, using a sensor such as a thermocouple.

Objectives of Data Acquisition System

- It must acquire the necessary data, at correct speed and at the correct time.
- Use of all data efficiently to inform the operator about the state of the plant.
- It must be able to collect, summarise and store data for diagnosis of operation and record purpose.
- It must be reliable and not have a down time greater than 0.1%.

Classification of Data Acquisition system:

1. Analog data acquisition system
2. Digital data acquisition system

1. Analog data acquisition system:

Basic Components of Analog data acquisition system are Transducers:

The transducer is used to convert the physical quantity into an electrical signal.

Signal Conditioner:

Signal conditioners are used for amplifying, modifying (or) selecting certain portions of such signals.

Multiplexing:

- Multiplexing is the process of sharing a single channel with more than one input.
- It accepts multiple analog inputs with the help of multiplexers; we can transmit more than one quantity using same channel.

Calibrating Equipment:

- Before each test, there is a pre-calibration and after after each test, there is a post-calibration.

Integrating Equipment:

- This block is used for integration or summation of a quantity. The digital techniques are normally used for integration purposes.

Visual Display devices:

- These are necessary to monitor the input signal continuously.
- These devices include panel mounted meters, numerical displays, single (or) multichannel CRO's and storage type CRO's.

Analog Recorders:

- These are required to record type output signal.

Analog Recorders include strip chart recorders, magnetic tape recorders.

Analog Computers:

- The function of DAS is not only to record data acquired by the transducers and the sensors, but also to reduce this data to desired form.

- The output voltage of an analog computer can either be recorded in analog form or be converted to a digital form for further computations.

High speed cameras and T.V equipment:

- In any industrial process such as engine testing and aerodynamic testing it is not possible for the test operator to have a view of the equipment being tested.

- \therefore closed circuit TV is used to enable the operator to make visual observation of the test.

- Also high speed cameras are employed to obtain a complete visual record of the process for further analysis.

2. Digital Data Acquisition System:

Various component of digital Data Acquisition system are

Transducers:

- It converts physical parameters into electrical quantities.

Signal conditioners:

- Signal conditioners usually includes the supporting circuitry for the transducer.

Multiplexers:

It accepts multiple analog inputs and connects them sequentially to one measuring instrument.

Signal converter:

Signal converter translates the analog signal, to a form acceptable by the analog to digital converter (ADC). An example of a signal converter is an amplifier used for amplifying low level voltage produced by strain gauges or thermocouples.

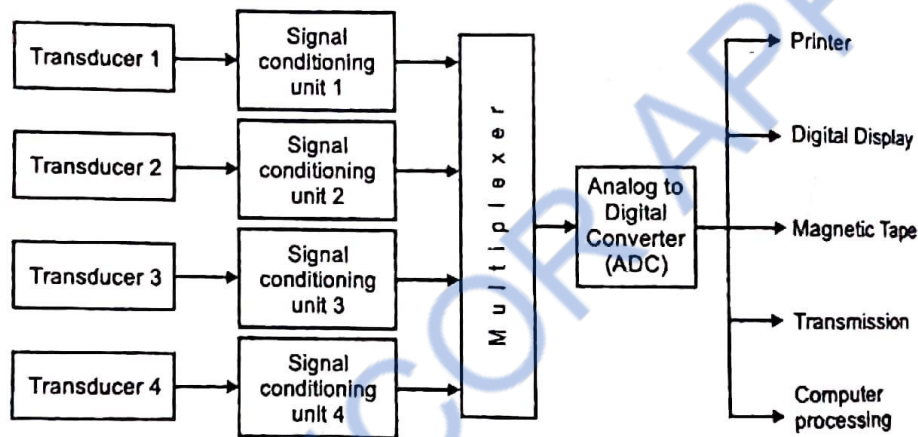
Analog to Digital Converter:

- Analog to digital converter converts the analog voltage to its equivalent digital form.
- The output of ADC may be displayed visually (or) recording on a digital recorder.

Digital Recorder

- It records digital information on punched cards, paper tape, magnetic tape, type written pages.

Configuration of data acquisition system:

The factors that decide the configuration and the subsystems of the data acquisition system are as follows

- (i) Resolution and Accuracy
- (ii) Numbers of channels to be monitored
- (iii) Sampling rate per channel
- (iv) signal conditioning requirement of each channel
- (v) Cost

(i) Single channel data acquisition system

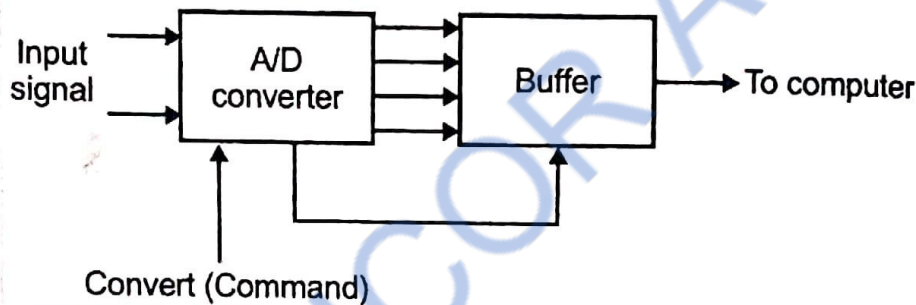

- It consists of a signal conditioner followed by an analog to digital converter (ADC).
- The outputs are in digital code words, including over-range indication, polarity information and a status output to indicate whether the output digits are valid.
- The digital output is further supplied to a storage (or) printout device (or) to a digital computer for analysis.
- The digital panel meter (DPM) is a well known example of such a system.
- Two major drawbacks are

1. It is slow and the Binary Coded Decimal (BCD) digital coding has to be changed into binary coding, if the output is to be processed by digital equipment.
2. While free running, the data from ADC is transferred to the interface registers at a rate determined by DPM itself, rather than by a command originating from the external interface.

2. Multichannel data acquisition system

(a) Multichannel analog multiplexed system:

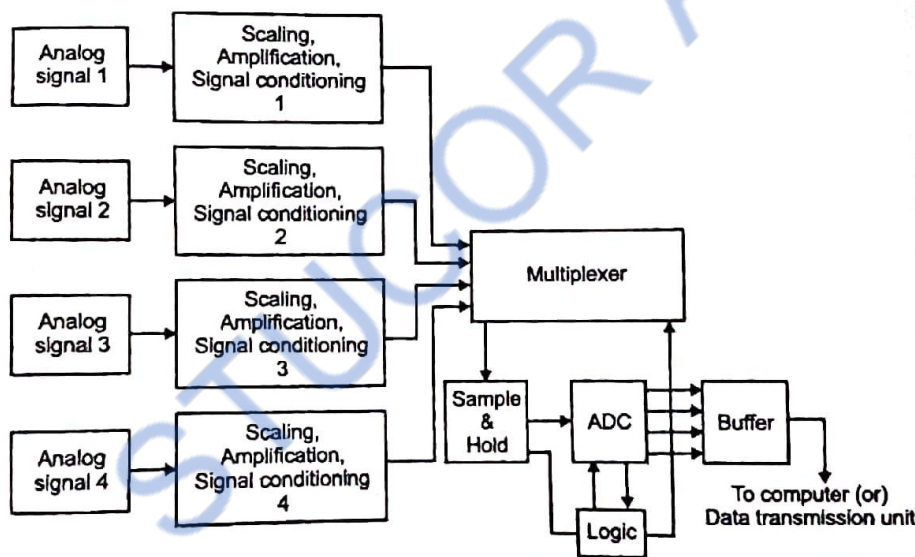

- The individual analog signals are applied to Scaling, Amplification, signal conditioning, whenever necessary to the multiplexer.
- These are further converted to digital signals by using ADCs sequentially. The multiplexer is made to seek the next channel to be converted while the previous

data stored in the S/H is converted into digital form.

- When the conversion is complete, the status line from the converter causes the S/H to return to the sample mode and acquires the signal of the next channel.
- on completion of acquisition, immediately or by command, the S/H is switched to the hold mode, a conversion begins again the multiplexer selects the next channel.
- This method is relatively slower than systems where the S/H outputs or even ADC outputs are multiplexed.

(b) Multiplexing the outputs of sample-hold (S/H) circuit.

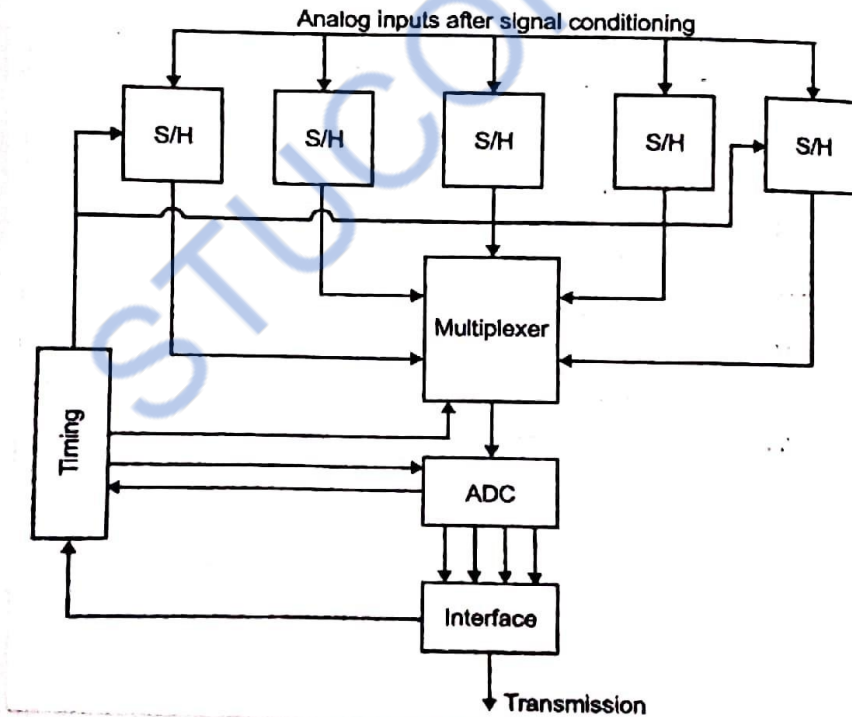

© Multiplexing after analog to digital conversion:

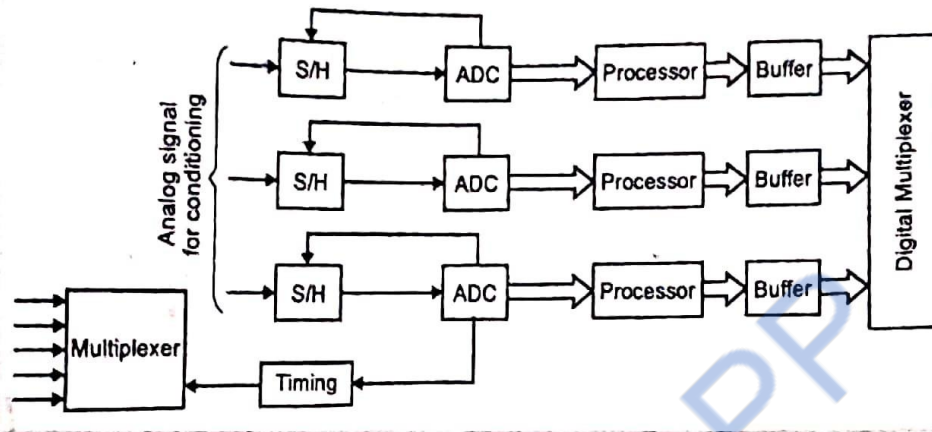

© Multiplexing low level data:

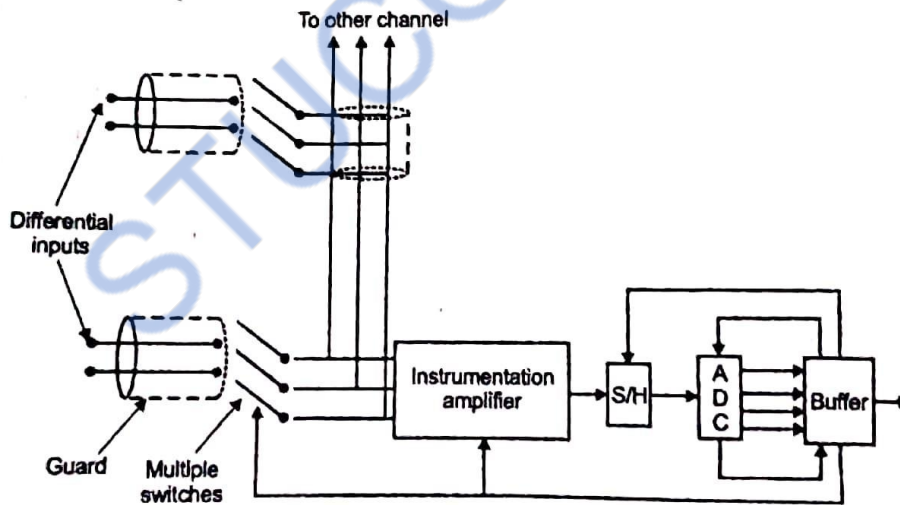

Measurement of three phase power by Two wattmeter method.

Two wattmeter method

1) Star connected load,

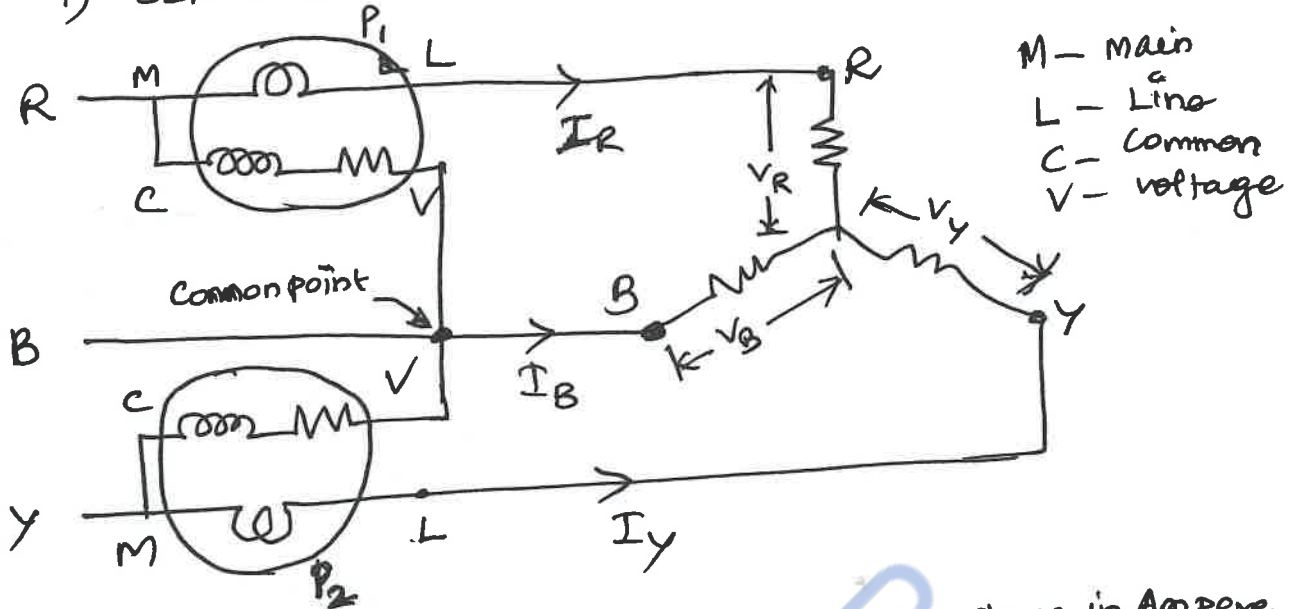

I_R - Instantaneous current flowing through R-phase in Ampere

I_Y - Instantaneous current flowing through Y-phase in Ampere

I_B - Instantaneous current flowing through B-phase in Ampere.

V_R - Instantaneous voltage across R-phase in Volt

V_Y - Instantaneous voltage across Y-phase in Volt

V_B - Instantaneous voltage across B-phase in Volt

Instantaneous reading of wattmeter 1 (W_1) = $P_1 = I_R (V_R - V_B)$ → ①

Instantaneous reading of wattmeter 2 (W_2) = $P_2 = I_Y (V_Y - V_B)$ → ②

Let Total power = $P_1 + P_2$

$$P_1 + P_2 = I_R (V_R - V_B) + I_Y (V_Y - V_B)$$

$$P_1 + P_2 = I_R V_R - I_R V_B + I_Y V_Y - I_Y V_B \rightarrow ③$$

$$\text{Let } I_R + I_Y + I_B = 0.$$

$$\therefore I_R + I_Y = -I_B \rightarrow ④$$

From ③

$$P_1 + P_2 = V_R I_R + V_Y I_Y - I_R V_B - I_Y V_B$$

$$P_1 + P_2 = V_R I_R + V_Y I_Y - V_B (I_R + I_Y)$$

$$P_1 + P_2 = V_R I_R + V_Y I_Y - V_B (-I_B)$$

$$\boxed{P_1 + P_2 = V_R I_R + V_Y I_Y + V_B I_B} \rightarrow ⑤$$

$$\left[\begin{array}{l} \text{as } \\ \text{from } \end{array} I_R + I_Y = -I_B \right]$$

Derivation of two wattmeter method for a balanced star connected load.

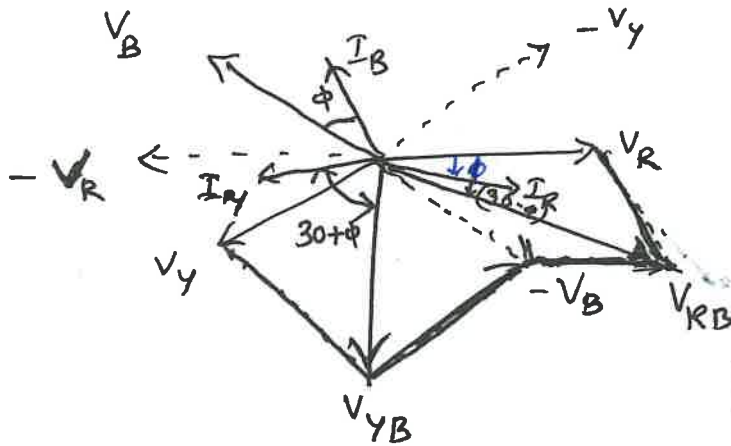

Angle between I_R and $V_{RB} = 30 - \phi$

and

Angle between I_Y and $V_{YB} = 30 + \phi$

For balanced load,

Phase voltages = $V_R = V_Y = V_B = V$

Line voltages = $V_{RY} = V_{YB} = V_{BR} = \sqrt{3}V$

Phase currents = $I_R = I_Y = I_B = I$

Wattmeter 1, P_1 :

Current through wattmeter 1, $I_1 = I_R$

Voltage across wattmeter 1, $V_1 = V_{RB}$

Angle between I_R and $V_{RB} = (30 - \phi)$

\therefore wattmeter reading, $P_1 = V_{RB} I_R \cos(30 - \phi) \rightarrow \textcircled{1}$

Wattmeter 2, P_2 :

Current through wattmeter 2, $I_2 = I_Y$

Voltage across wattmeter 2, $V_2 = V_{YB}$

Angle between V_{YB} and $I_Y = 30 + \phi$

\therefore wattmeter reading, $P_2 = V_{YB} I_Y \cos(30 + \phi) \rightarrow \textcircled{2}$

$P_1 = V_{RB} I_R \cos(30 - \phi)$

$\therefore P_1 = \sqrt{3} V I \cos(30 - \phi)$

$\therefore P_2 = V_{YB} I_Y \cos(30 + \phi)$

$P_2 = \sqrt{3} V I \cos(30 + \phi)$

$P_1 + P_2 = \sqrt{3} V I \cos(30 - \phi) + \sqrt{3} V I \cos(30 + \phi)$

$P_1 + P_2 = \sqrt{3} V I [\cos(30 - \phi) + \cos(30 + \phi)]$

$P_1 + P_2 = \sqrt{3} V I [\cos 30 \cos \phi + \sin 30 \sin \phi + \cos 30 \cos \phi - \sin 30 \sin \phi]$

$P_1 + P_2 = \sqrt{3} V I [2 \cos 30 \cos \phi]$

$\because \cos 30 = \frac{\sqrt{3}}{2}$

$P_1 + P_2 = \sqrt{3} V I [2 \times \frac{\sqrt{3}}{2} \cos \phi]$

$\because \sqrt{3} \sqrt{3} = 3$

$\therefore P_1 + P_2 = 3 V I \cos \phi \text{ Watts}$

Delta connection:

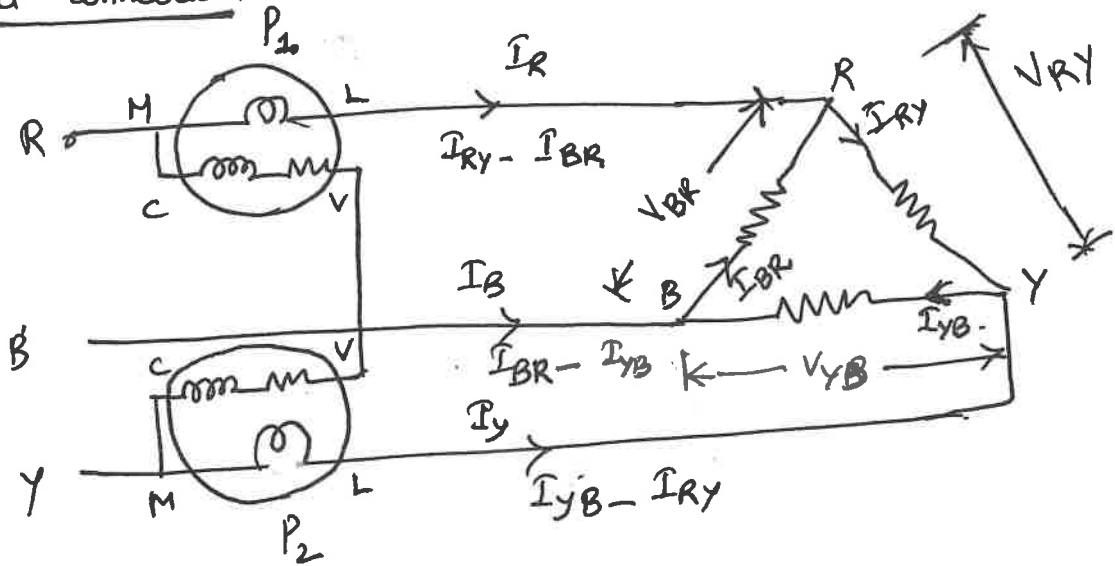

wattmeter reading 1,

$$P_1 = -V_{BR} (I_{RY} - I_{BR}) \longrightarrow \textcircled{1}$$

wattmeter reading 2,

$$P_2 = V_{YB} (I_{YB} - I_{RY}) \longrightarrow \textcircled{2}$$

Sum of two wattmeter readings,

$$P_1 + P_2 = -V_{BR} (I_{RY} - I_{BR}) + V_{YB} (I_{YB} - I_{RY})$$

$$P_1 + P_2 = -V_{BR} I_{RY} + V_{BR} I_{BR} + V_{YB} I_{YB} - V_{YB} I_{RY} \longrightarrow \textcircled{1}$$

$$P_1 + P_2 = V_{YB} I_{YB} + V_{BR} I_{BR} - I_{RY} (V_{BR} + V_{YB}) \longrightarrow \textcircled{1}$$

Apply KCL, $V_{RY} + V_{YB} + V_{BR} = 0$.

$$\therefore \boxed{V_{BR} + V_{YB} = -V_{RY}} \longrightarrow \textcircled{2}$$

Sub $\textcircled{2}$ in $\textcircled{1}$, we get,

$$P_1 + P_2 = V_{YB} I_{YB} + V_{BR} I_{BR} - I_{RY} (-V_{RY})$$

$$\therefore P_1 + P_2 = V_{YB} I_{YB} + V_{BR} I_{BR} + V_{RY} I_{RY}$$

On rearranging, we get

$$\boxed{P_1 + P_2 = V_{RY} I_{RY} + V_{YB} I_{YB} + V_{BR} I_{BR}}$$