

CE8391 CONSTRUCTION MATERIALS NOTES

Chapter No	Title	Page No
1	Stones – Bricks – Concrete Blocks	
	1.1 Characteristics Of Good Building Stone	1
	1.2 Testing of Stones	2
	1.3 Deterioration Of Stones	8
	1.4 Durability of Stones	9
	1.5 Preservation of Stones	9
	1.6 Selection of Stones	10
	1.7 Bricks	10
	1.8 Classification of bricks	11
	1.9 Manufacturing Of Bricks	13
	1.10 Testing of Bricks	19
	1.11 Fire-Clay Bricks Or Refractory Bricks	22
2	Lime – Cement – Aggregates – Mortar	
	2.1 Lime Mortar	24
	2.2 Composition Of Cement Clinker	25
	2.3 Hydration Of Cement	28
	2.4 Rate Of Hydration	29
	2.5 Manufacture Of Cement	29
	2.6 Testing of Cement	32
	2.7 Types Of Cement	45
	2.8 Testing Of Aggregates	50
3	Concrete	
	3.1 Concrete	59
	3.2 Ingredients	59
	3.3 Manufacturing Process	59
	3.4 Ready Mixed Concrete (RMC)	66
	3.5 Properties of Fresh Concrete:	68
	3.6 Properties Of Hardened Concrete	69

		70
	3.8 High Strength Concrete	71
	3.9 High Performance Concrete	71
	3.10 Self Compacting Concrete	72
	3.11 Durability of Concrete	72
4	Timber And Other Materials	
	4.1 Timber	75
	4.2 Market Forms of Timber	75
	4.3 Plywood	75
	4.3.1 Types	75
	4.3.2 Grades	76
	4.3.3 Applications	76
	4.4 Veneer	79
	4.4.1 Types of Veneer	80
	4.4.2 Advantages of using veneers	80
	4.5 Thermocol	81
	4.6 Panels of Laminates	81
	4.6.1 Types	81
	4.6.2 Sizes	81
	4.6.3 Applications	81
	4.7 Steel	82
	4.7.1 Manufacturing Methods	82
	4.7.2 Properties and Uses	83
	4.7.3 Properties of Steel	83
	4.8 Aluminum	87
	4.8.1 Applications	90
	4.8.2 Other names	91
	4.8.3 The selective use of ACP	91
	4.9 Composition	92

4.10 Characteristics Of An Ideal Pain	96
4.10.1 Preparation Of Paint	96
5 Modern Materials	
5.1 Glass	98
5.1.1 Constituents	98
5.1.2 Manufacture	99
5.1.3 Classification	101
5.1.4 Commercial Forms	101
5.2 Ceramic	103
5.3 Fibre glass reinforced plastic	103
5.4 Clay products	104
5.4.1 Clay And Its Classifications	104
5.4.2 Physical Properties Of Clays	105
5.5 Fire-Clay Or Refractory Clay	106
5.6 Composite materials	107
5.7 Applications of laminar composites	109
5.8 Fibre textiles	109
5.9 Reinforced Earth	109

Chapter 1

Stones – Bricks – Concrete Blocks

Stone as building material – Criteria for selection – Tests on stones – Deterioration and Preservation of stone work – Bricks – Classification – Manufacturing of clay bricks – Tests on bricks – Compressive Strength – Water Absorption – Efflorescence – Bricks for special use – Refractory bricks – Cement, Concrete blocks – Light weight concrete blocks.

1.1 Characteristics Of Good Building Stone

A good building stone should have the following qualities.

Appearance: For face work it should have fine, compact texture; light-coloured stone is preferred as dark colours are likely to fade out in due course of time.

Structure: A broken stone should not be dull in appearance and should have uniform texture free from cavities, cracks, and patches of loose or soft material. Stratifications should not be visible to naked eye.

Strength: A stone should be strong and durable to withstand the disintegrating action of weather. Compressive strength of building stones in practice range between 60 to 200 N/mm².

Weight: It is an indication of the porosity and density. For stability of structures such as dams, retaining walls, etc. heavier stones are required, whereas for arches, vaults, domes, etc. light stones may be the choice.

Hardness: This property is important for floors, pavements, aprons of bridges, etc. The hardness is determined by the Mohs scale

Toughness: The measure of impact that a stone can withstand is defined as toughness. The stone used should be tough when vibratory or moving loads are anticipated.

Porosity and Absorption: Porosity depends on the mineral constituents, cooling time and structural formation. A porous stone disintegrates as the absorbed rain water freezes, expands, and causes cracking. Permissible water absorption for some of the stones is given in Table 1

Table 1 24-Hours Water Absorption of Stones by Volume

S.No.	Types of Stone	Water absorption (%) not greater than)
1.	Sandstone	10
2.	Limestone	10
3.	Granite	1
4.	Trap	6
5.	Shale	10
6.	Gneiss	1
7.	Slate	1
8.	Quartzite	3

Seasoning: The stone should be well seasoned.

Weathering: The resistance of stone against the wear and tear due to natural agencies should be high.

Workability: Stone should be workable so that cutting, dressing and bringing it out in the required shape and size may not be uneconomical.

Fire Resistance: Stones should be free from calcium carbonate, oxides of iron, and minerals having different coefficients of thermal expansion. Igneous rock show marked disintegration principally because of quartz which disintegrates into small particles at a temperature of about 575°C. Limestone, however, can withstand a little higher temperature; i.e. up to 800°C after which they disintegrate.

Specific Gravity: The specific gravity of most of the stones lies between 2.3 to 2.5.

Thermal Movement: Thermal movements alone are usually not trouble-some. However, joints in

coping and parapets open-out in letting the rain water causing trouble. Marble slabs show a distinct distortion when subjected to heat. An exposure of one side of marble slab to heat may cause that side to expand and the slab warps. On cooling, the slab does not go back to its original shape.

1.2 Testing Of Stones

Building stones are available in large quantity in various parts of the country and to choose and utilize them for their satisfactory performance, it is necessary to test the stone for its strength properties, durability and quality.

Durability Test

crystallization test is prescribed by Bureau of Indian Standards. The durability (soundness) test is performed to find out the capacity of stone to resist disintegration and decomposition.

Smith Test:

Some of the tests to check the durability of stone are as follows. Of these tests, the Smith Test: them in a glass of clean water, one-third full. If the water becomes slightly cloudy, the stone is good and durable. If water becomes dirty, it indicates that the stone contains too much of earthy and mineral matter. Break off the freshly quarried stone chippings to about the size of a rupee coin and put boiling

Brard's Test

— solution of sulphate of soda (Glauber's salt) and are weighed. These are then removed and suspended for few days and weighed again. The loss in weight indicates the probable effect of frost.

Acid Test

— for frost resistance Few small pieces of freshly quarried stone are immersed in conditions. 100 g of stone chips are kept in a 5 per cent solution of H_2SO_4 or HCl for 3 days. Then the chips are taken out and dried. The sharp and firm corners and edges are indication of sound stone. This test is used to test the cementing material of sand stone. to check weather resistance confirms the power of stones to withstand the atmospheric

Crystallization Test (IS 1126):

hours and are weighed (W_1). The specimens are suspended in 14 per cent sodium sulphate solution

Three test pieces of 50 mm diameter and 50 mm height are dried for 24 hours and are weighed (W_1). The specimens are suspended in 14 per cent sodium sulphate solution taken out of the solution and kept in air for 4 hours. They are then oven dried at a temperature of $105 \pm 5^\circ C$ for 24 hours and then cooled at room temperature. This process is repeated for 30 cycles. The specimens are weighed (W_2) and the difference in weight is found. This test is repeated thirty times and the loss in weight after every five cycles is obtained. The change in weight (20% to 30%) indicates the degree of decay of stone. Durability should be expressed in percentage as change in the weight. The average of three test results should be reported as durability value.

$$\text{Change in weight} = \frac{W_1 - W_2}{W_1}$$

where W_1 is the original weight of the specimen and W_2 is the weight of the specimen after 30 cycles of the test.

Crushing Test

Compressive Strength Test (IS: 1121 (Part I)) Samples of stone weighing at least 25 kg each of the unweathered specimen should be obtained from quarry. To test stone for compressive strength, specimen pieces in the form of cubes or cylinders are made from samples of rock. The lateral dimension or diameter of test piece should not be less than 50 mm and the ratio of height to diameter or lateral dimension should be 1:1. A minimum of three specimen pieces are tested in each saturated and dry conditions. Separate tests should be made for the specimen when the load to parallel to the rift and perpendicular to the rift. In all twelve test pieces should be used.

The specimen pieces of diameter or lateral dimension 50 mm are immersed in water at 20 to 30°C for 72 hours and are tested in saturated condition. The specimen pieces are also tested in dry condition by drying them in an oven at $105 \pm 5^\circ C$ for 24 hours and then cooled in a desiccator to 20–30°C. These are tested in universal testing machine. The load is applied gently at a rate of 14 N/mm² per minute until the resistance of the specimen piece to the increasing load breaks down and no greater load is sustained.

The compressive strength of the specimen piece is the maximum load in Newtons supported by it before failure occurs divided by the area of the bearing face of the specimen in mm². The average of the three results in each condition separately should be taken for the purpose of reporting the compressive strength of the sample.

When the ratio of height to diameter or lateral dimension differs from unity by 25 per cent or more, the compressive strength is calculated by the following expression.

$$C_c = \frac{C_p}{\frac{E b \phi}{\hat{E} h \hat{U}}}$$

$\begin{matrix} 0.778 & 0.222 \\ \hat{E} & \hat{U} \end{matrix}$

- where
- C_c = compressive strength of standard specimen piece
 - C_p = compressive strength of the specimen having a height greater than the diameter or lateral dimension
 - b = diameter or lateral dimension
 - h = height

The crushing strength of stones varies in the range of 15–100 N/mm².

Transverse Strength Test (IS: 1121 (Part II)): To test stone for transverse strength, specimen pieces are made in the form of blocks 200 × 50 × 50 mm. These are tested in saturated and dry conditions similar to as explained in the compressive strength test. Test apparatus used for testing is shown in Fig. 1. Each specimen piece is supported upon two self-aligning bearers

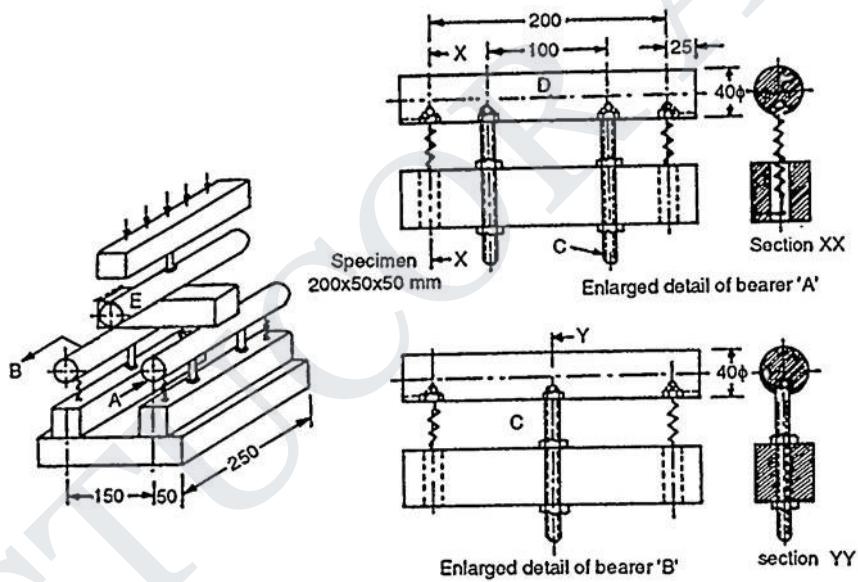

Fig. 1 Arrangement for Transverse Strength Test of Stones

A and B, 40 mm in diameter, the distance between centres of bearers being 150 mm. Bearer A is supported horizontally on two bearer screws C, which carry hardened steel balls D. Bearer B is supported on one such bearer screw and ball. The load is then applied centrally on the specimen piece at a uniform rate of 2 kN/min through a third bearer E, also 40 mm in diameter, placed midway between the supports upon the upper surface of the specimen S and parallel to the supports.

The average of the three results (separately for saturated and dry condition) should be taken for the purpose of determining transverse strength of sample. Any specimen giving result as much as 15 per cent below the average value should be examined for defects.

The transverse strength of the specimen is given by

$$R = \frac{3WL}{2bd^2}$$

where R = transverse strength in N/mm^2
 W = central breaking load in N
 L = length of span in mm
 b = average width in mm of the test piece at the mid section
 d = average depth in mm of the test piece at the mid section

Tensile Strength Test (IS: 1121 (Part III))

Three cylindrical test pieces of diameter not less than 50 mm and the ratio of diameter to height 1:2 are used to determine the tensile strength of the stone in each saturated (kept in water for 3 days at 20 to 30°C) and dry condition (dried in an oven at $105 \pm 5^\circ\text{C}$ for 24 hours and cooled at room temperature). The general arrangement for testing tensile strength of stone is shown in Fig. 3.11. Each test piece to be tested is sandwiched in between two steel plates of width 25 mm, thickness 10 mm and length equal to the length of test piece. The load is applied without shock and increased continuously at a uniform rate until the specimen splits and no greater load is sustained. The maximum load applied to the specimen is recorded.

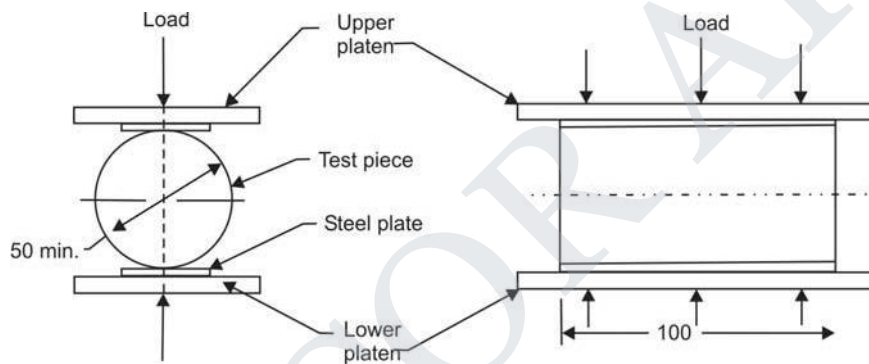

Fig. 2 General Arrangement for Testing Tensile Strength of Building Stone

Split tensile strength, $S = \frac{2W}{S dL}$

where

S = split tensile strength (N/mm^2)

W = applied load (N)

d = diameter of specimen (mm), and

L = length of specimen (mm)

The average of three results separately for each condition should be reported as split tensile strength of the sample. In case any test piece gives a value of as much as 15 per cent below the average, it should be examined for defects and if found defective the test piece should be rejected.

Shear Strength Test (IS: 1121 (Part IV))

The test is carried out either in Jhonson shear tool (Fig. 3) or Dutton punching shear device (Fig. 4). Three test pieces are used for conducting the test in each of the saturated and dry condition.

Test piece for use in Jhonson shear tool should be bars 50×50 mm in section and not less than 100 mm in length and that for use with the Dutton punching shear device should be slabs 30 mm in thickness, 100 mm in width and not less than 100 mm in length.

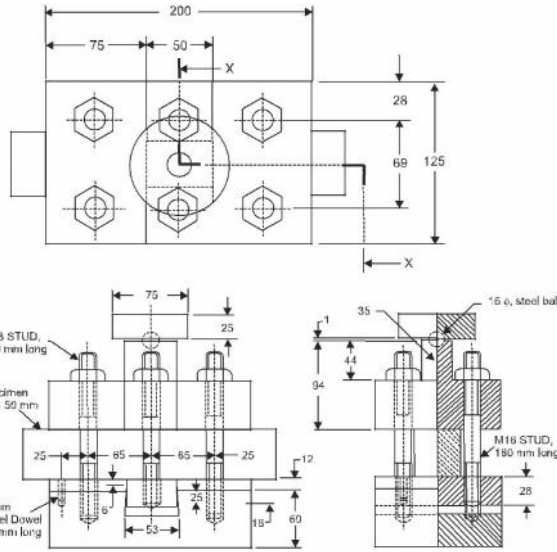
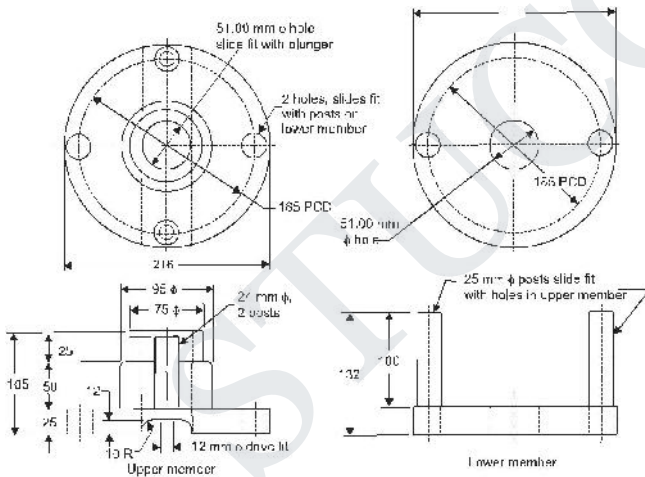
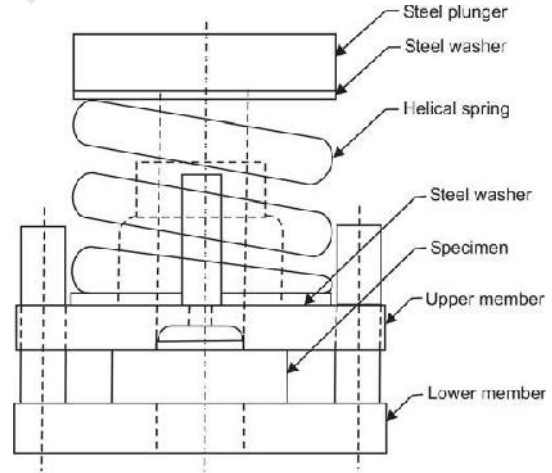

Fig. 3 Detail of Modified Johnson Shear Tool



(a) Details of Parts



(b) Assembled view

Fig. 4 Details of Dutton Punching Shear Device

The test piece is carefully centred in the shear tool and the bolts drawn up tightly. The tool is then centred in the testing machine with the centre of the spherical block in contact with the centre of the top portion of the plunger of the shear tool. The speed of the moving head of the testing machine during load application should not be more than 1 mm/min. During the test, the beam of the testing machine should be kept constantly in floating position. The shear strength of test piece is calculated by

$$S = \frac{W}{2A}$$

where

S = Shear strength (N/mm²)

W = total maximum load (N)

A = area of the centre cross-section of test piece (mm²)

The average of all the three results separately for each condition is calculated and taken as the shear strength of the test piece.

Using Dutton Punching Shear Device

Centre lines are laid over one surface of the slab. Thickness of the slab is measured at three points approximately equidistant around the circumference of a 50 mm circle centred on the intersection of the two center lines. The test piece is centred in the punching device keeping it under the plunger. The punching device is then centred in the testing machine with the centre of the spherical bearing block in contact with the centre of the top portion of the plunger of the shear device. The speed of the moving head of the testing machine during load application should not be more than 1 mm/min. During the test, the beam of the testing machine should be kept constantly in floating position. The shear strength of the test piece is calculated by

$$S = \frac{W_t - W_i}{S \cdot D \cdot T}$$

where

S = Shear strength (N/mm²)

W_t = total maximum load (N)

W_i = initial load (N) required to bring the plunger in contact with the surface of specimen

D = diameter (mm) of the plunger

T = thickness (mm) of the specimen

The average of all the three results separately for each condition is calculated and taken as shear strength of the test piece.

Absorption Test (IS: 1124)

The selected test pieces of stone are crushed or broken and the material passing 20 mm IS Sieve and retained on 10 mm IS Sieve is used for the test. The test piece weighing about 1 kg is washed to remove particles of dust and immersed in distilled water in a glass vessel at room temperature 20 to 30° C for 24 hours. Soon after immersion and again at the end of

soaking period, entrapped air is removed by gentle agitation achieved by rapid clock-wise and anti-clock-wise rotation of the vessel. The vessel is then emptied and the test piece allowed to drain. The test piece is then placed on a dry cloth and gently surface dried with the cloth. It is transferred to a second dry cloth when the first one removes no further moisture. The test piece is spread out not more than one stone deep on the second cloth and left exposed to atmosphere away from direct sunlight or any other source of heat for not less than 10 minutes until it appears to be completely surface dry. The sample is then weighed (B).

The sample is then carefully introduced in a 1000 ml capacity measuring cylinder and distilled water is poured by means of 100 ml capacity measuring cylinder while taking care to remove entrapped air, until the level of water in the larger cylinder reaches 1000 ml mark. The quantity of water thus added is recorded in ml or expressed in gram weight (C).

The water in the larger cylinder is drained and the sample is carefully taken out and dried in an oven at 100 to 110°C for not less than 24 hours. It is then cooled in a desiccators to room temperature and weighed (A). The room temperature during the test is recorded.

$$\text{Apparent specific gravity} = \frac{A}{\frac{B}{1000} - \frac{C}{A}}$$

$$\text{Water absorption} = \frac{B - A}{A} \times 100$$

$$\text{Apparent Porosity} = \frac{B - A}{C} \times 100$$

The true porosity shall be calculated from the following formula:

$$\text{True Porosity} = \frac{\text{True specific gravity} - \text{Apparent specific gravity}}{\text{True Specific gravity}}$$

Where

A = Weight of oven-dry test piece (g)

B = Weight of saturated surface-dry test piece (g)

C = Quantity of water added in 1000 ml jar containing the test piece (g)

Hardness: This test is performed by scratching a stone with knife on Mohs scale.

Toughness: This test is performed by breaking the stone with a hammer. Toughness is indicated by resistance to hammering.

The various natural agents such as rain, heat, etc. and chemicals deteriorate the stones with time.

Rain

Rain water acts both physically and chemically on stones. The physical action is due to the erosive and transportation powers and the latter due to the decomposition, oxidation and hydration of the minerals present in the stones.

Physical Action:

consequent disintegration.

Chemical Action: Alternate wetting by rain and drying by sun causes internal stresses in the stones and to its deterioration.

Decomposition: In industrial areas the acidic rain water reacts with the constituents of stones leading action of chemically active water. The hydrated silicate and the carbonate forms of the alkaline materials are very soluble in water and are removed in solution leaving behind a hydrated silicate of alumina (Kaolinite). The disintegration of alkaline silicate of alumina in stones is mainly because of the decomposition of felspar is represented as



Oxidation and Hydration: Rock containing iron compounds in the forms of peroxide, sulphide and carbonate are oxidised and hydrated when acted upon by acidulated rain water. As an example the peroxide—FeO is converted into ferric oxide—Fe₂O₃ which combines with water to form FeO.nH₂O. This chemical change is accompanied by an increase in volume and results in a physical change manifested by the liberation of the neighbouring minerals composing the rocks. As another example iron sulphide and siderite readily oxidize to limonite and liberates sulphur, which combines with water and oxygen to form sulphuric acid and finally to sulphates.

Frost

In cold places frost pierces the pores of the stones where it freezes, expands and creates cracks.

Wind

Since wind carries dust particles, the abrasion caused by these deteriorates the stones.

Temperature Changes

Expansion and contraction due to frequent temperature changes cause stone to deteriorate especially if a rock is composed of several minerals with different coefficients of linear expansion.

Vegetable Growth

Roots of trees and weeds that grow in the masonry joints keep the stones damp and also secrete organic and acidic matters which cause the stones to deteriorate. Dust particles of organic or nonorganic origin may also settle on the surface and penetrate into the pores of stones. When these come in contact with moisture or rain water, bacteriological process starts and the resultant micro-organism producing acids attack stones which cause decay.

Mutual Decay

When different types of stones are used together mutual decay takes place. For example when sandstone is used under limestone, the chemicals brought down from limestone by rain water to the sandstone will deteriorate it.

Chemical Agents

Smokes, fumes, acids and acid fumes present in the atmosphere deteriorate the stones. Stones containing CaCO₃, MgCO₃ are affected badly.

Lichens

These destroy limestone but act as protective coats for other stones. Molluses gradually weaken and ultimately destroy the stone by making a series of parallel vertical holes in limestones and sandstones.

Quarrying and cutting have a great bearing on the weathering properties of stones. Stone from top ledges of limestone, granite, and slate and from the exposed faces of the rock bed is likely to be less hard and durable. Highly absorbent stone should not be quarried in freezing weather since the rock is likely to split. The method of blasting and cutting also influences the strength of the stone and its resistance to freezing and temperature changes. Small, uniformly distributed charge of blasting powder has a lesser weakening effect than large concentrations of explosives. A porous stone is less durable than a dense stone, since the former is less resistant to freezing. Also, rocks with tortuous pores and tubes are more apt to be injured by freezing than those of equal porosity having straight pores and tubes. Repeated hammering in cutting is likely to injure the stone. Polished stone is more enduring than rough surfaced work, since the rain slides off the former more easily. Stones from stratified rocks should be placed along the natural bed in order to secure maximum weathering resistance. Pyrite, magnetite and iron carbonate oxidize in weathering and cause discolouration of the stone in which they are present. Since oxidation is accompanied by a change in volume, the surrounding structure is weakened.

1.5 Preservation Of Stones

Preservation of stone is essential to prevent its decay. Different types of stones require different treatments. But in general stones should be made dry with the help of blow lamp and then a coating of paraffin, linseed oil, light paint, etc. is applied over the surface. This makes a protective coating over the stone. However, this treatment is periodic and not permanent. When treatment is done with the linseed oil, it is boiled and applied in three coats over the stone. Thereafter, a coat of dilute ammonia in warm water is applied.

The structure to be preserved should be maintained by washing stones frequently with water and steam so that dirt and salts deposited are removed from time to time. However, the best way is to apply preservatives. Stones are washed with thin solution of silicate of soda or potash. Then, on drying a solution of CaCl₂ is applied over it. These two solutions called Szerelmy's liquid, combine to form silicate of lime which fills the pores in stones. The common salt formed in this process is washed afterwards. The silicate of lime forms an insoluble film which helps to protect the stones.

Sometimes lead paint is also used to preserve the stones, but the natural colour of the stone is spoilt. Painting stone with coal tar also helps in the preservation but it spoils the beauty of the stone. Use of chemicals should be avoided as far as possible, especially the caustic alkalis. Although cleaning is easy with chemicals, there is the risk of introducing salts which may subsequently cause damage to the stone.

In industrial towns, stones are preserved by application of solution of baryta, Ba(OH)₂ — Barium hydrate. The sulphur dioxide present in acid reacts on the calcium contents of stones to form calcium sulphate. Soot and dust present in the atmosphere adhere to the calcium sulphate and form a hard skin. In due course of time, the calcium sulphate so formed flakes off and exposes fresh stone surface for further attack. This is known as sulphate attack. Baryta reacts with calcium sulphate deposited on the stones and forms insoluble barium sulphate and calcium hydroxide. The calcium hydroxide absorbs carbon dioxide from the air to form calcium carbonate.

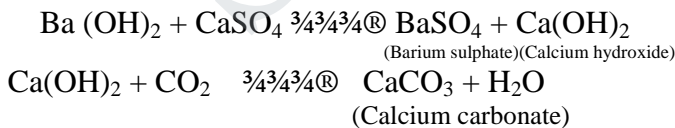

The question whether or not stone preservatives should be used on old and decayed stone is a difficult one. Real evidence of the value of various treatments is most difficult to assess. The treatments, if carefully applied under favourable circumstances, may result in an apparent slowing down of the rate of decay. However, the rate of decay of stone is so slow that a short period experience is of very little value in establishing the effectiveness of the treatment. Also, there is some evidence that treatments which appear to be successful for few years, fail to maintain the improvement. In fact, the value of preservatives is not yet proved, and they may actually be detrimental if judged over a long period.

1.6 Selection Of Stones

The conditions which govern the selection of stone for structural purposes are cost, fashion, ornamental value and durability, although the latter property is frequently overlooked or disregarded. Cost is largely influenced by transportation charges, difficulties in quarrying and cutting, the ornamental features, and the durability of stone. The type of dressing of stone may make a difference to the cost, particularly with the stones derived from igneous rocks. When the cost of quarried stone to cost of finished stone is considered, it will be found that the labour cost is far greater than the price of the stone. Thus, a difference in the price between two alternative stones is unimportant and it would be unwise to reject a more durable stone on the grounds that it was costly.

Another factor which should be considered is the suitability of the stone for the type of design, for example, for a highly carved design if, by mistake, a harder stone such as granite is selected the cost will be affected. Colour, arrangement and shape of mineral constituents greatly influence fashion and ornamental value. One of the first factors influencing the selection of stone for a particular work will be colour.

It is important that the designer is aware about how the colour is likely to change after long exposure and in particular how it may vary in polluted atmospheres. As an example limestone, being slightly soluble in water, will remain clean in portions facing rain but retain a film of soot in sheltered areas. This results in strong colour contrast.

Resistance to fire and weathering—
 the rock—

according to its exposure conditions. Limestones when used in areas not exposed to rain but acted upon by sulphur gases of polluted atmosphere, factors which and largely influenced by the kind and substitution of blisters and drake most important detail that of flaking ability. Kind varies primarily to external work only, although the air inside the building is almost equally polluted, probably due to the damper conditions inside.

Limestones, sandstones and granites all tend to crack and spall when exposed to fire, and there is really little to choose between them in this respect.

1.7 Bricks

One of the oldest building material brick continues to be a most popular and leading construction material because of being cheap, durable and easy to handle and work with. Clay bricks are used for building-up exterior and interior walls, partitions, piers, footings and other load bearing structures.

A brick is rectangular in shape and of size that can be conveniently handled with one hand. Brick may be made of burnt clay or mixture of sand and lime or of Portland cement concrete. Clay bricks are commonly used since these are economical and easily available. The length, width and height of a brick are interrelated as below:

Length of brick = $2 \times \text{width of brick} + \text{thickness of mortar}$

Height of brick = width of brick

Size of a standard brick (also known as modular brick) should be $19 \times 9 \times 9$ cm and $19 \times 9 \times 4$ cm. When placed in masonry the $19 \times 9 \times 9$ cm brick with mortar becomes $20 \times 10 \times 10$ cm.

However, the bricks available in most part of the country still are $9" \times \quad \times 3"$ and are known as field bricks. Weight of such a brick is 3.0 kg. An indent called frog, 1–

provided for 9 cm high bricks. The size of frog should be $10 \times 4 \times 1$ cm. The purpose of providing frog is to form a key for holding the mortar and therefore, the bricks are laid with frogs on top. Frog is not provided in 4 cm high bricks and extruded bricks. 2 cm deep, as shown in Fig. 5, is

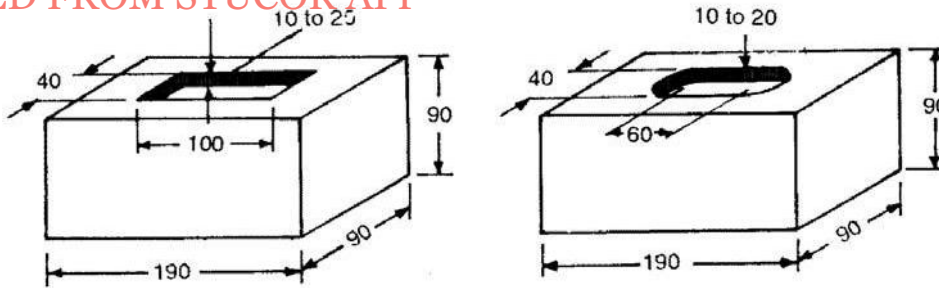

Fig. 5 Bricks with Frog

1.8 Classification Of Bricks

On Field Practice

Clay bricks are classified as first class, second class, third class and fourth class based on their physical and mechanical properties.

First Class Bricks

1. These are thoroughly burnt and are of deep red, cherry or copper colour.
2. The surface should be smooth and rectangular, with parallel, sharp and straight edges and square corners.
3. These should be free from flaws, cracks and stones.
4. These should have uniform texture.
5. No impression should be left on the brick when a scratch is made by a finger nail.
6. The fractured surface of the brick should not show lumps of lime.
7. A metallic or ringing sound should come when two bricks are struck against each other.
9. Water absorption should be 12–15% of its dry weight when immersed in cold water for 24 hours. The crushing strength of the brick should not be less than 10 N/mm^2 . This limit varies with different Government organizations around the country.

Uses: First class bricks are recommended for pointing, exposed face work in masonry structures, flooring and reinforced brick work.

Second Class Bricks are supposed to have the same requirements as the first class ones except that

1. Small cracks and distortions are permitted.
2. A little higher water absorption of about 16–20% of its dry weight is allowed.
3. The crushing strength should not be less than 7.0 N/mm^2 .

Uses: Second class bricks are recommended for all important or unimportant hidden masonry works and centering of reinforced brick and reinforced cement concrete (RCC) structures.

Third Class Bricks are underburnt. They are soft and light-coloured producing a dull sound when struck against each other. Water absorption is about 25 per cent of dry weight.

Uses : It is used for building temporary structures.

Fourth Class Bricks are overburnt and badly distorted in shape and size and are brittle in nature.

Uses: The ballast of such bricks is used for foundation and floors in lime concrete and road metal.

On Strength

The Bureau of Indian Standards (BIS) has classified the bricks on the basis of compressive strength and is as given in Table 2

Table 2 Classification of Bricks based on Compressive Strength (IS: 1077)

Class	Average compressive strength not less than (N/mm^2)
35	35.0
30	30.0
25	25.0

20	20.0
17.5	17.5
15	15.0
12.5	12.5
10	10.0
7.5	7.5
5	5.0
3.5	3.5

Notes: 1. The burnt clay bricks having compressive strength more than 40.0 N/mm² are known as heavy duty bricks and are used for heavy duty structures such as bridges, foundations for industrial buildings, multistory buildings, etc. The water absorption of these bricks is limited to 5 per cent.

2. Each class of bricks as specified above is further divided into subclasses A and B based on tolerances and shape. Subclass-A bricks should have smooth rectangular faces with sharp corners and uniform colour. Subclass-B bricks may have slightly distorted and round edges.

	Subclass-A		Subclass-B	
	Dimension (cm)	Tolerance (mm)	Dimension (cm)	Tolerance (mm)
Length	380	± 12	380	± 30
Width	180	± 6	180	± 15
Height				
(i) 9 cm	180	± 6	180	± 15
(ii) 4 cm	80	± 3	80	± 6

On the Basis of Use

Common Brick is a general multi-purpose unit manufactured economically without special reference to appearance. These may vary greatly in strength and durability and are used for filling, backing and in walls where appearance is of no consequence.

Facing Bricks are made primarily with a view to have good appearance, either of colour or texture or both. These are durable under severe exposure and are used in fronts of building walls for which a pleasing appearance is desired.

Engineering Bricks are strong, impermeable, smooth, table moulded, hard and conform to defined limits of absorption and strength. These are used for all load bearing structures.

On the Basis of Finish

Sand-faced Brick has textured surface manufactured by sprinkling sand on the inner surfaces of the mould.

Rustic Brick has mechanically textured finish, varying in pattern.

On the Basis of Manufacture

Hand-made: These bricks are hand moulded.

Machine-made: Depending upon mechanical arrangement, bricks are known as wire-cut bricks—bricks cut from clay extruded in a column and cut off into brick sizes by wires; pressed-bricks—when bricks are manufactured from stiff plastic or semi-dry clay and pressed into moulds; moulded bricks—when bricks are moulded by machines imitating hand mixing.

On the Basis of Burning

Pale Bricks are underburnt bricks obtained from outer portion of the kiln.

Body Bricks are well burnt bricks occupying central portion of the kiln.

Arch Bricks are overburnt also known as clinker bricks obtained from inner portion of the kiln.

frogs not exceeding 20 per cent of the total volume are permitted.

Perforated:

Small holes not exceeding 25 per cent of the volume of the brick are permitted; alternatively,

1.9 Manufacturing Of Bricks

Additives in the Manufacture of Bricks

Cellular: Certain additives such as fly ash, sandy loam, rice husk ash, basalt stone dust, etc. are often required not only to modify the shaping, drying and firing behaviour of clay mass, but also to help conserve agricultural land and utilise waste materials available in large quantities. These additives should, however, have a desirable level of physical and chemical characteristics so as to modify the behaviour of clay mass within the optimum range without any adverse effect on the performance and durability. Some of the basic physio-chemical requirements of conventional additives are as under:

Note: Small holes are less than 20 mm or less than 500 mm² in cross section. Holes closed at one end exceed 20 per cent of the volume.

The total of holes, which need not be small, may exceed 25 per cent of the volume of the brick, however, have a desirable level of physical and chemical characteristics so as to modify the behaviour of clay mass within the optimum range without any adverse effect on the performance and durability. Some of the basic physio-chemical requirements of conventional additives are as under:

Fly Ash:

alluvial, red, black, marine clays, etc. The fly ash contains amorphous glassy material, mullite, haematite, magnetite, etc. and shows a chemical composition similar to brick earths. These silicates also help towards strength development in clay bodies on firing, when mixed in optimum proportion depending on the physio-chemical and plastic properties of soils to be used for brick making. The proportion of fly ash mixed as an additive to the brick earth should be optimum to reduce drying shrinkage, check drying losses and to develop strength on firing without bloating or black coring in fired product. The crystallites present in the fly ash should comply with the resultant high temperature phases in the finished product.

Sandy Loam:

highly plastic soil mass containing expanding group of clay minerals. Sandy loam should preferably have a mechanical composition as specified below. The material should, however, meet the other requirements as well. Addition of sandy loam is often found effective in controlling the drying behaviour of

Clay	(< 2 micron)	10%
Silt	20 micron)	50%
Sand	(> 20 micron)	60%

Rice Husk Ash: The ash should preferably have unburnt carbon content in the range of 3–5% and should be free from extraneous material. It can be used with plastic black red soils showing excessive shrinkage.

Basalt Stone Dust: Basalt stone occurs underneath the black cotton soil and its dust is a waste product available in large quantity from basalt stone crushing units. The finer fraction from basalt stone units is mixed with soil mass to modify the shaping, drying and firing behaviour of bricks. The dust recommended for use as an additive with brick earth should be fine (passing 1 mm sieve), free from coarse materials or mica flakes and should be of non-calcitic or dolomitic origin.

The operations involved in the manufacture of clay bricks are represented diagrammatically in Fig. 5

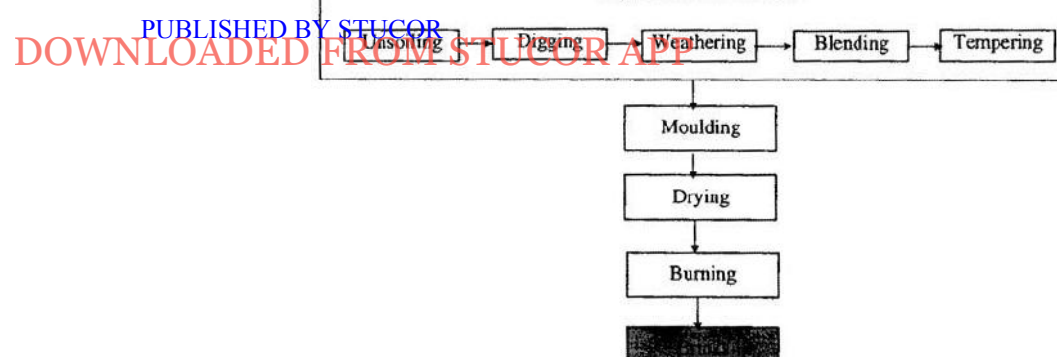

Fig. 5 Operations Involved in Manufacturing of Clay Bricks

Preparation of Brick Earth

It consists of the following operations.

Unsoiling: The soil used for making building bricks should be processed so as to be free of gravel, coarse sand (practical size more than 2 mm), lime and kankar particles, organic matter, etc. About 20 cm of the top layer of the earth, normally containing stones, pebbles, gravel, roots, etc., is removed after clearing the trees and vegetation.

Digging: After removing the top layer of the earth, proportions of additives such as fly ash, sandy loam, rice husk ash, stone dust, etc. should be spread over the plane ground surface on volume basis. The soil mass is then manually excavated, puddled, watered and left over for weathering and subsequent processing. The digging operation should be done before rains.

Weathering: Stones, gravels, pebbles, roots, etc. are removed from the dug earth and the soil is heaped on level ground in layers of 60–120 cm. The soil is left in heaps and exposed to weather for at least one month in cases where such weathering is considered necessary for the soil. This is done to develop homogeneity in the mass of soil, particularly if they are from different sources, and also to eliminate the impurities which get oxidized. Soluble salts in the clay would also be eroded by rain to some extent, which otherwise could have caused scumming at the time of burning of the bricks in the kiln. The soil should be turned over at least twice and it should be ensured that the entire soil is wet throughout the period of weathering. In order to keep it wet, water may be sprayed as often as necessary. The plasticity and strength of the clay are improved by exposing the clay to weather.

Blending: The earth is then mixed with sandy-earth and calcareous-earth in suitable proportions to modify the composition of soil. Moderate amount of water is mixed so as to obtain the right consistency for moulding. The mass is then mixed uniformly with spades. Addition of water to the soil at the dumps is necessary for the easy mixing and workability, but the addition of water should be controlled in such a way that it may not create a problem in moulding and drying. Excessive moisture content may effect the size and shape of the finished brick

Tempering:

(by plasticity, we mean the property which wet clay has of being permanently deformed without cracking). It should preferably be carried out by storing the soil in a cool place in layers of about 30 cm thickness for not less than 36 hours. This will ensure homogeneity in the mass of clay for subsequent processing. For manufacturing good brick, tempering is done in pug mills and the operation is called pugging.

Pug mill consists of a conical iron tube as shown in Fig. 6. The mill is sunk 60 cm into the earth. A vertical shaft, with a number of horizontal arms fitted with knives, is provided at the centre of the tube. This central shaft is rotated with the help of bullocks yoked at the end of long arms. However, steam, diesel or electric power may be used for this purpose. Blended earth along with required water, is fed into the pug mill from the top. The knives cut through the clay and break all the clods or lump-clays when the shaft rotates. The thoroughly pugged clay is then taken out from opening provided in the side near the bottom. The yield from a pug mill is about 1500 bricks.

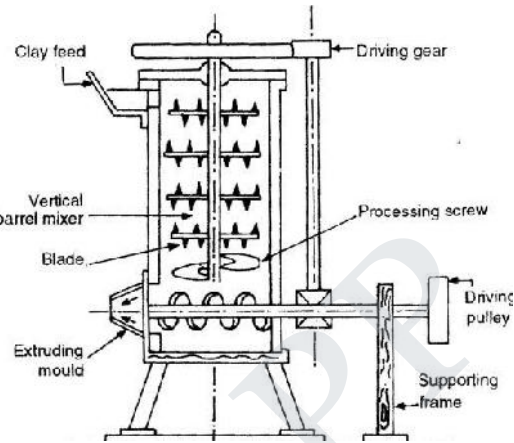

Fig 6 Pug Mill

Moulding

It is a process of giving a required shape to the brick from the prepared brick earth. Moulding may be carried out by hand or by machines. The process of moulding of bricks may be the soft-mud (hand moulding), the stiff-mud (machine moulding) or the dry-press process (moulding using maximum 10 per cent water and forming bricks at higher pressures). Fire-brick is made by the soft mud process. Roofing, floor and wall tiles are made by dry-press method. However, the stiff-mud process is used for making all the structural clay products.

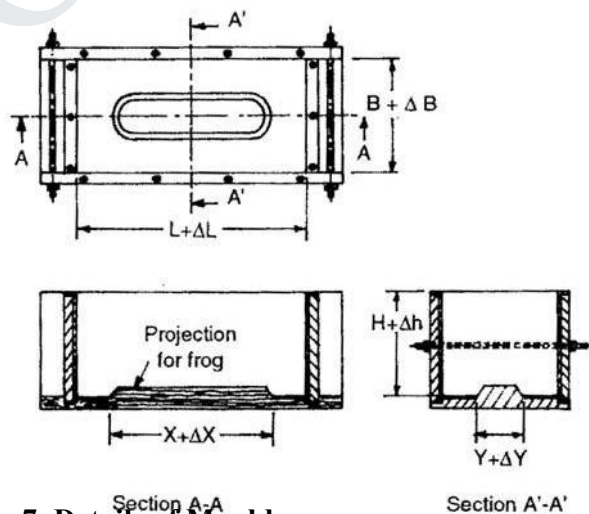

Fig 7. Details of Mould

Hand Moulding: A typical mould is shown in Fig. 7. Hand moulding is further classified

as ground moulding and table moulding.

Ground Moulding: In this process, the ground is levelled and sand is sprinkled on it. The moulded bricks are left on the ground for drying. Such bricks do not have frog and the lower brick surface becomes too rough. To overcome these defects, moulding blocks or boards are used at the base of the mould. The process consists of shaping in hands a lump of well pugged earth, slightly more than that of the brick volume. It is then rolled into the sand and with a jerk it is dashed into the mould. The moulder

then gives blows with his fists and presses the earth properly in the corners of the mould with his thumb. The surplus clay on the top surface is removed with a sharp edge metal plate called strike (Fig. 8) or with a thin wire stretched over the mould. After this the mould is given a gentle slope and is lifted leaving the brick on the ground to dry.

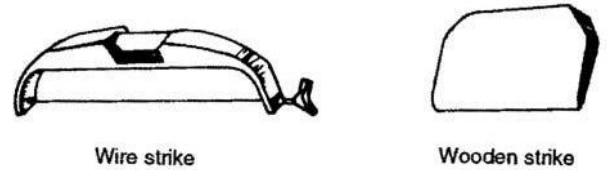

Notes: (i) This method is adopted when a large and level land is available.

(ii) To prevent the moulded bricks from sticking to the side of the mould, sand is sprinkled on the inner sides of the mould, or the mould may be dipped in water every time before moulding is done. The bricks so produced are respectively called sand moulded and slop moulded bricks, the former being better since they provide sufficient rough surface necessary for achieving a good bond between bricks and mortar.

Table Moulding: The bricks are moulded on stock boards nailed on the moulding table

(Fig. 9). Stock boards have the projection for forming the frog. The process of filling clay in the mould is the same as explained above. After this, a thin board called pallet is placed over the

mould. The mould containing the brick is then smartly lifted off the stock board and inverted so that the moulded clay along with the mould rests on the pallet. The mould is then removed as explained before and the brick is carried to the drying site.

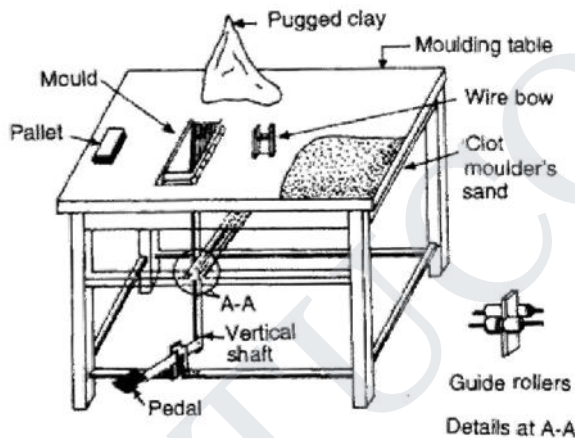

Fig. 9(a) Brick Moulding Table

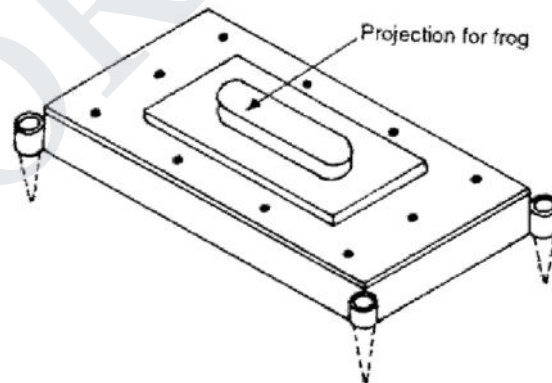

Fig. 9(b) Stock Board

Machine Moulding can be done by either of the following processes:

Plastic Method: The pugged, stiffer clay is forced through a rectangular opening of brick size by means of an auger. Clay comes out of the opening in the form of a bar. The bricks are cut from the bar by a frame consisting of several wires at a distance of brick size as shown in Fig. 10. This is a quick and economical process.

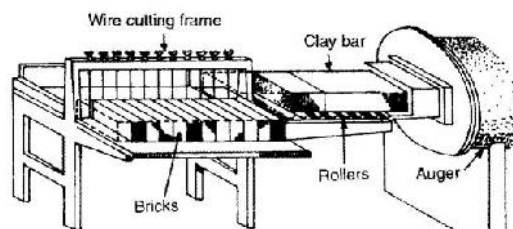

Fig. 10 Plastic Moulding

Dry-press Method: The moist, powdered clay is fed into the mould on a mechanically operated press, where it is subjected to high pressure and the clay in the mould takes the shape of bricks. Such pressed bricks are more dense, smooth and uniform than ordinary bricks. These are burnt carefully as they are likely to crack.

Drying

Green bricks contain about 7 –

upon the method of manufacture. The object of drying is to remove the moisture to control the shrinkage and save fuel and time during burning. The drying shrinkage is dependent upon pore spaces within the clay and the mixing water. The addition of sand or ground burnt clay reduces shrinkage, increases porosity and facilitates drying. The moisture content is brought down to about 3 per cent under exposed conditions within three to four days. Thus, the strength of the green bricks is increased and the bricks can be handled safely.

Clay products can be dried in open air driers or in artificial driers. The artificial driers are of two types, the hot floor drier and the tunnel drier. In the former, heat is applied by a furnace placed at one end of the drier or by exhaust steam from the engine used to furnish power and is used for fire bricks, clay pipes and terracotta. Tunnel driers are heated by fuels underneath, by steam pipes, or by hot air from cooling kilns. They are more economical than floor driers. In artificial driers, temperature rarely exceeds 120°C. The time varies from one to three days. In developing countries, bricks are normally dried in natural open air driers (Fig. 11). They are stacked on raised ground and are protected from bad weather and direct sunlight. A gap of about 1.0 m is left in the adjacent layers of the stacks so as to allow free movement for the workers

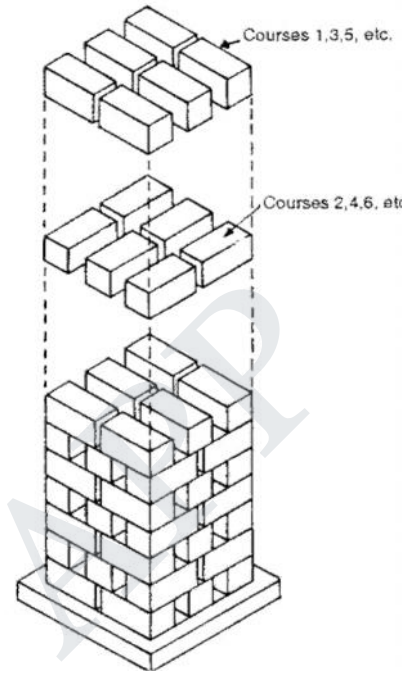

Fig. 11 Method of Drying Bricks

Burning

The burning of clay may be divided into three main stages.

Dehydration (400–650°C): This is also known as water smoking stage. During dehydration, (1) the water which has been retained in the pores of the clay after drying is driven off and the clay loses its plasticity, (2) some of the carbonaceous matter is burnt, (3) a portion of sulphur is distilled from pyrites. (4) hydrous minerals like ferric hydroxide are dehydrated, and (5) the carbonate minerals are more or less decarbonated. Too rapid heating causes cracking or bursting of the bricks. On the other hand, if alkali is contained in the clay or sulphur is present in large amount in the coal, too slow heating of clay produces a scum on the surface of the bricks.

Oxidation Period (650–900°C): During the oxidation period, (1) remainder of carbon is eliminated and, (2) the ferrous iron is oxidized to the ferric form. The removal of sulphur is completed only after the carbon has been eliminated. Sulphur on account of its affinity for oxygen, also holds back the oxidation of iron. Consequently, in order to avoid black or spongy cores, oxidation must proceed at such a rate which will allow these changes to occur before the heat becomes sufficient to soften the clay and close its pore. Sand is often added to the raw clay to produce a more open structure and thus provide escape of gases generated in burning.

Vitrification—To convert the mass into glass like substance — the temperature ranges from 900–1100°C for low melting clay and 1000–1250°C for high melting clay. Great care is required in cooling the bricks below the cherry red heat in order to avoid checking and cracking. Vitrification period may further be divided into (a) incipient vitrification, at which the clay has softened sufficiently to cause

adherence but not enough to close the pores or cause loss of space—

scratched by the knife; (b) complete vitrification, more or less well-marked by maximum shrinkage; (c) viscous vitrification, produced by a further increase in temperature which results in a soft molten mass, a gradual loss in shape, and a glassy structure after cooling. Generally, clay products are vitrified to the point of viscosity. However, paving bricks are burnt to the stage of complete vitrification to achieve maximum hardness as well as toughness.

Burning of bricks is done in a clamp or kiln. A clamp is a temporary structure whereas kiln is a permanent one.

Burning in Clamp or Pazawah:

alternate layers. The amount of fuel is reduced successively in the top layers. Each brick tier consists of 4—

A typical clamp is shown in Fig. 2.9. The bricks and fuel are placed in cent loading of the clamp, the fuel in the lowest layer is fired and the remaining loading of bricks and fuel is carried out hurriedly. The top and sides of the clamp, are plastered with mud. Then a coat of 5 layers of bricks. Some space is left between bricks for free circulation of hot gasses. After 30 per cowdung is given, which prevents the escape of heat. The production of bricks is 2—

process is completed in six months. This process yields about 60 per cent first class bricks.

Kiln Burning: The kiln used for burning bricks may be underground, e.g. Bull's trench kiln or overground, e.g. Hoffman's kiln. These may be rectangular, circular or oval in shape. When the process of burning bricks is continuous, the kiln is known as continuous kiln, e.g. Bull's trench and Hoffman's kilns.

On the other hand if the process of burning bricks is discontinuous, the kiln is known as intermittent kiln.

Intermittent Kiln: The example of this type of an over ground, rectangular kiln is shown in Fig. 2.10.

After loading the kiln, it is fired, cooled and **Kiln**

unloaded and then the next loading is done. Since the walls and sides get cooled during reloading and are to be heated again during next firing, there is wastage of fuel.

Continuous Kiln: The examples of continuous kiln are Hoffman's kiln (Fig. 2.11) and Bull's trench kiln (Fig. 2.12). In a continuous kiln, bricks are stacked in various chambers wherein the bricks undergo different treatments at the same time. When the bricks in one of the chambers is fired, the bricks in the next set of chambers are dried and preheated while bricks in the other set of chambers are loaded and in the last are cooled.

Note: In the areas where black cotton soil occur, a more elaborate method of processing is followed. The clay, which may be black or a mixture of black and yellow, is first washed free of the lime kankar in the 'GHOL' tanks. The slurry is then run off to the setting tanks. After 3–4 days when the clay has settled down, the supernatant water is bucketed off. Opening material like powdered grog of fine coal ash (passing 2.00 mm sieve), which opens up the texture of clay mass, is then added in predetermined proportions. This is usually 30 to 40 per cent of the mass of clay. A solution of 0.5 per cent sodium chloride may also be added at this stage to prevent lime bursting. The clay is then thoroughly mixed with the opening materials added and allowed to dry further for a period of 3–4 days till the mix attains the correct moulding consistency. Grog is prepared by lightly calcining lumps of black cotton soil (about 10 to 15 cm dia.) in a clamp at about 700° to 750°C. Coal ash, fire wood, brambles, etc. may be used as fuel. The fuel and clay lumps are arranged in alternate layers in the clamp. After calcination the clay is pulverized in a machine, such as disintegrator, a hammer mill or a pan-mill to a fineness of less than 2.0 mm.

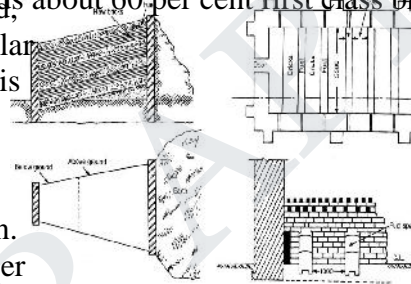

Fig12 Clamp or Pazawah Fig 13 Intermittent

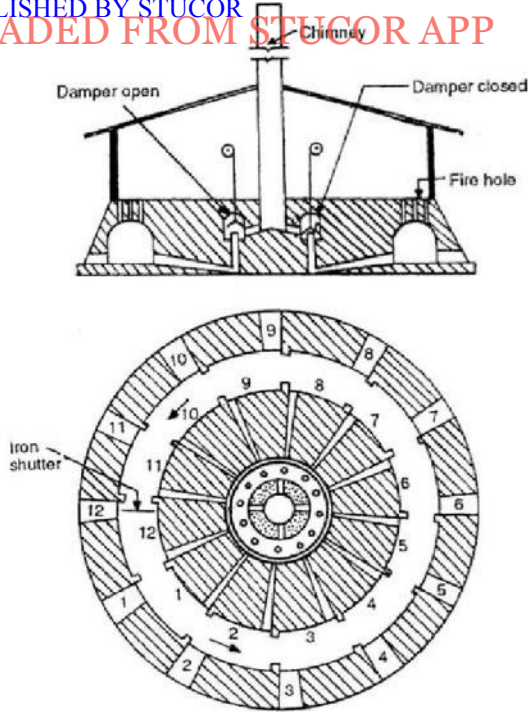

Fig. 14 Hoffman's Continuous Kiln

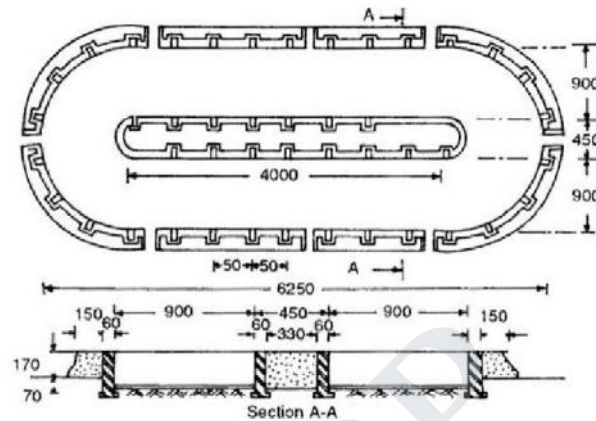

Fig. 15 Bull's Trench Kiln

1.10 Testing Of Bricks

About fifty pieces of bricks are taken at random from different parts of the stack to perform various tests. For the purpose of sampling, a lot should contain maximum of 50,000 bricks. The number of bricks selected for forming a sample are as per Table 2.3, (IS: 5454). The scale of sampling for physical characteristics is given in Table 2.4.

Table 2. Scale of Sampling and Permissible Number of Defectives for Visual and Dimensional Characteristics

No. of bricks in the lot	For characteristics specified for individual brick		For dimensional characteristics specified
	No. of bricks to be selected	Permissible No. of Defectives in sample	
2001 to 10000	20	1	40
10001 to 35000	32	2	60
35001 to 50000	50	3	80

Note: In case the lot contains 2000 or less bricks, the sampling shall be subject to agreement between the purchaser and supplier.

Lot size	Sampling size for compressive strength, breaking load, transverse strength, density, water absorption and efflorescence	Permissible No. of defectives for efflorescence	Permissible No. of defectives	Warpage Permissible No. of defectives
2001 to 10000	5	0	10	0
10001 to 35000	10	0	20	1
35001 to 50000	15	1	30	2

Note: In case the lot contains 2000 or less bricks, the sampling shall be subject to agreement between the purchaser and supplier.

Dimension Test (IS: 1077): 20 pieces out of selected pieces (Table) are taken and are laid flat as shown in Fig. 16.

The tolerances (Section) on the sizes of bricks are fixed by giving maximum and minimum dimensions, not on individual bricks but on batches of 20 bricks chosen at random.

It follows from this method of measurement that batches are likely to contain, bricks outside the prescribed limit of tolerance. Such lots should be rejected to avoid complaints about the variation of perpend.

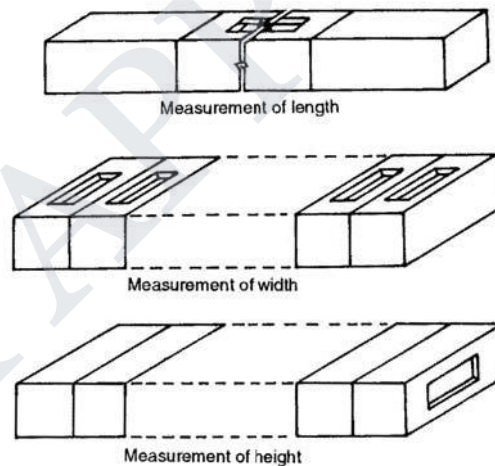

Fig. 16 Measurement of Tolerances of Common Building Bricks

Water Absorption Test (IS: 3495 (Part II)): The existence of minute pores confers marked capillary properties on brick ceramics. In particular all bricks absorb water by capillary action. The percentage of water absorption is a very valuable indication of the degree of burning. Vitrification, in the true sense, corresponds to such a degree of compactness that the absorption of the brick is not over 3 per cent after 48 hours of immersion. It has been reported that for absorption less than 5 per cent danger from frost is negligible.

Water absorption does not necessarily indicate the behavior of a brick in weathering. Low absorption (< 7 %) usually indicates a high resistance to damage by freezing, although some type of bricks of much higher absorption may also be frost resistance. Since expansive force of water freezing in the pores of a clay product depends upon the proportion of pore space occupied, the ratio of the absorption after 24 hours submersion to the absorption after boiling for 5 hours (C_{24}/B_5) appears to be a better criterion of resistance to freezing than the percentage of absorption.

The durability of a brick may be tested by frost action, i.e., by alternate wetting and drying. The absorption test has long been considered a measure of durability, although the basis for this assumption is questionable. The suction rate of the brick at the time it is laid exercises a mark influence on the mortar bond. Too rapid withdrawal of water from the mortar by the brick produces a weak bond. The rate at which a brick absorbs water, frequently called its suction rate, maybe measured by immersing one face of the brick in water. The one minute water uptake (initial rate of absorprion) is taken as the suction rate. For long periods of immersion in this test, the total wieght of water absorbed per unit

$$w = A\ddot{O}t$$

where, A is the water absorption coefficient
and t is the time elapsed in the test.

The standard methods of finding the absorption value of the bricks are discussed below. If absorption by volume is desired it can be obtained by multiplying the weight percentage by the apparent specific gravity. **24 Hours Immersion Cold Water Test:** Dry bricks are put in an oven at a temperature of 105° to 115°C till these attain constant mass. The weight (W_1) of the bricks is recorded after cooling them to room temperature. The bricks are then immersed in water at a temperature of 27° ± 2°C for 24 hours. The specimens are then taken out of water and wiped with a damp cloth. Three minutes, thereafter it is weighed again and recorded as W_2 .

$$\text{The water absorption in \%} = \frac{W_2 - W_1}{W_1} \times 100$$

The average water absorption shall not be more than 20 per cent by weight upto class 12.5 and 15 per cent by weight for higher classes.

Five Hours Boiling Water Test: The weight of the oven dried bricks (W_1) is recorded as above. Then the specimen is immersed in the water and boiled for five hours, followed by cooling down to 27° ± 2°C by natural loss of heat within 16–19 hours. The specimen is taken out of water and wiped with a damp cloth and the weight is recorded as W_3 .

$$\text{The water absorption in \%} = \frac{W_3 - W_1}{W_1} \times 100$$

Compressive Strength Test (IS: 3495 (Part I)): The crushing affords a basis for comparing the quality of bricks but is of little value in determining the strength of a masonry wall, since the latter depends primarily on the strength of mortar. Six bricks are taken for the compressive strength test although it may be found that an individual brick varies by 20% or more from the average, the permissible stresses allowed for load bearing walls take account of this, being based on an average strength of six bricks. It is, therefore, both unnecessary and uneconomical to insist that every bricks is above a certain strength. As a criterion of structural strength for brick, the transverse failure in a wall or pavement is likely to occur on account of improper bedment. For testing bricks for compressive strength from a sample the two bed faces of bricks are ground to provide smooth, even and parallel faces. The bricks are then immersed in water at room temperature for 24 hours. These are then taken out of water and surplus water on the surfaces is wiped off with cotton or a moist cloth. The frog of the brick is flushed level with cement mortar and the brick is stored under damp jute bags for 24 hours followed by its immersion in water at room temperature for three days. The specimen is placed in the compression testing machine with flat faces horizontal and mortar filled face being upwards. Load is applied at a uniform rate of 14 N/m² per minute till failure. The maximum load at failure divided by the average area of bed face gives the compressive strength.

$$\text{Compressive strength (N/mm}^2\text{)} = \frac{\text{aximum load at failure (N)}}{\text{verage area of bed faces (mm}^2\text{)}}$$

The average of results shall be reported. The compressive strength of any individual brick tested in the sample should not fall below the minimum average compressive strength specified for the corresponding class of brick by more than 20

Warpage Test (IS:3495 (Part IV)): Warpage of the brick is measured with the help of a flat steel or glass surface and measuring ruler graduated in 0.5 mm divisions or wedge of steel $60 \times 15 \times 15$ mm (Fig. 17). For warpage

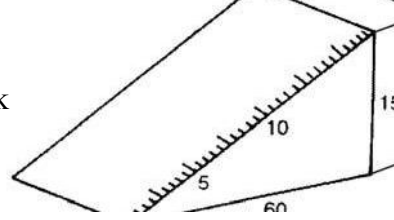

Fig. 17 Measuring Wedge

test, the sample consists of 10 bricks from a lot.

Concave Warpage: The flat surface of the brick is placed along the surface to be measured selecting the location that gives the greatest deviation from straightness. The greatest distance of brick surface from the edge of straightness is measured by a steel ruler or wedge.

Convex Warpage: The brick is placed on the plane surface with the convex surface in contact with the flat surface and the distances of four corners of brick are measured from the flat surface. The largest distance is reported as warpage.

The higher of the distance measured in concave and convex warpage tests is reported as warpage.

Efflorescence Test (IS: 3495 (Part III)): The ends of the brick are kept in a 150 mm diameter porcelain or glass dish containing 25 mm depth of water at room temperature (20° – 30° C) till the entire water is absorbed or evaporated. The water is again filled to 25 mm depth in the dish and allowed to be absorbed by the brick or evaporated. Presence of efflorescence is classified as below.

1. Nil — When the deposit of efflorescence is imperceptible.
2. Slight — When the deposit of efflorescence does not cover more than 10 per cent of the exposed area of the brick.
3. Moderate — When the deposit of efflorescence is more than 10 per cent but less than 50% of the exposed area of the brick.
4. Heavy — When the deposit of efflorescence is more than 50 per cent but the deposits do not powder or flake away the brick surface.
5. Serious — When the deposits are heavy and powder or flake away the brick surface.

The specifications limit the efflorescence to be not more than moderate (10–50%) up to class

12.5 and not more than slight (< 10 per cent) for higher classes.

1.11 Fire-Clay Bricks Or Refractory Bricks

Fire-clay bricks are made from fire-clay. The process of manufacturing is as of an ordinary brick, burnt at very high temperatures in special kilns (Hoffman's kiln). The raw materials used for the manufacture of fire bricks consist of flint clay and grog (burnt fire clay) as non-plastic materials and soft fire clay as plastic material. Fire clay mortar is used to clay refractory bricks.

Properties

1. The colour is whitish yellow or light brown.
2. The water absorption of fire-clay bricks varies from 4–10%
3. The minimum average compressive strength of the bricks should be 3.5 N/mm^2 .

Uses These are used for lining blast furnances, ovens, kilns, boilers and chimneys. The principal varieties of fire-clay bricks are as follows:

Acid Refractory Bricks consist of silica bricks (95–97% silica and 1–2% lime) and ganister bricks (ganister—a hard coloured sand stone containing 10 per cent clay and 2 per cent of lime), used in lining furnaces having siliceous and acidic slag, steel industry and coke oven. The softening temperature

ranges from 1700° to 1800°C. Silica bricks are hard and also possess good refractoriness under load. But they have tendency to spall during rapid temperature change therefore, these can not be used for lining of furnaces which have to be cooled and reheated frequently.

Basic Refractory Bricks consist of magnesia bricks (magnesia minimum 85 per cent, calcium oxide maximum 25 per cent and silica maximum 5.5 per cent) and bauxite bricks (minimum 85 per cent aluminium oxide and maximum 20 per cent clay). These are highly resistant to corrosion and are used for lining furnances having basic slag. Due to high thermal expansion and consequent poor resistance to spalling the use of these bricks is retracted to copper metallurgy and basic open hearth testing machine. A $75 \times 100 \times 300$ mm block is placed over the ridge of the tile and a load of 2.7 kN/min is applied on the block. The breaking load of individual tile is noted. It is divided by the length of tile. The results are reported in N/mm.

Lime – Cement – Aggregates – Mortar

Lime – Preparation of lime mortar – Cement – Ingredients – Manufacturing process – Types and Grades – Properties of cement and Cement mortar – Hydration – Compressive strength – Tensile strength – Fineness – Soundness and consistency – Setting time – Industrial byproducts – Fly ash – Aggregates – Natural stone aggregates – Crushing strength – Impact strength – Flakiness Index – Elongation Index – Abrasion Resistance – Grading – Sand Bulking.

2.1 Lime Mortar

Lime mortar is made by mixing lime, sand and water. Lime used for mortar may be fat lime (quick or hydrated lime) or hydraulic lime. Fat lime has high calcium oxide content. Its hardening depends on loss of water and absorption of carbon dioxide from the atmosphere and possible recrystallisation in due course. Hydraulic lime contains silica, alumina and iron oxide in small quantities. When mixed with water it forms putty or mortar having the property of setting and hardening under water.

Slaked fat lime is used to prepare mortar for plastering, while hydraulic lime is used for masonry construction and are most suitable for construction of chimneys and lightly loaded superstructure of buildings. The mix proportions of lime mortar for various types of works are given in Table 12.2.

Table 4 Mix Proportions

S.No.	Type of lime	Type of Lime	Sand	Fineness modulus of sand	Type of work
1.	Fat Lime	2	3	3	Plastering
		1.5	3	3	Pointing
2.	Hydraulic	3	2.5	2.5	Masonry

Notes:1. Sand in lime mortar is an adulterant, and reduces its shrinkage. Lime mortar becomes porous allowing air to penetrate and helps the mortar in hardening.

2. Lime mortar is not suitable for water-logged areas and damp situations.

Lime mortars have plasticity and placability, good cohesion with other surfacings and little shrinkage. They harden and develop strength very slowly continuously gaining strength over long period. Fat lime mortars do not set but stiffen only as water is lost by absorption (by masonry units) and evaporation. The gain in strength is a very slow reaction of lime with carbon dioxide absorbed from air.

Preparation

Manual Mixing Lime and sand in required quantities are placed on an impervious floor or in a tank (Fig. 18). The constituents are thoroughly mixed dry by turning them up and down with spades. Water is added and mixing is done again with spades till mortar of uniform colour and consistency is obtained.

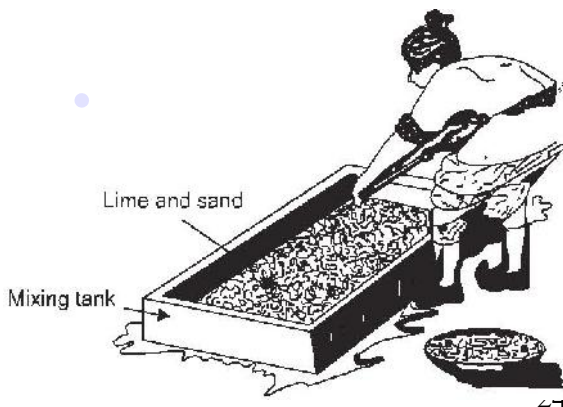
**Fig. 18 Manual Mixing**

Mill Mixing Mills used for preparing lime mortars in undeveloped countries may be a chakki or ghanni run by bullocks (Fig. 18) while a pan mill (Fig. 19) is used in developed countries. In the case of ghanni the required quantity of ingredients in the form of putty is put in the trench and grinding for 100 to 200 revolutions is carried out by moving stone roller. The operation takes about 2 to 3 hours for each batch of mix; the time required in a Pan mill is much less.

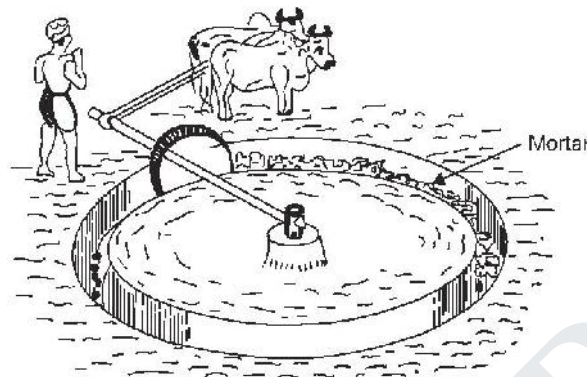

Fig. 19 Bullock Driven Mortar Mill (Ghanni)

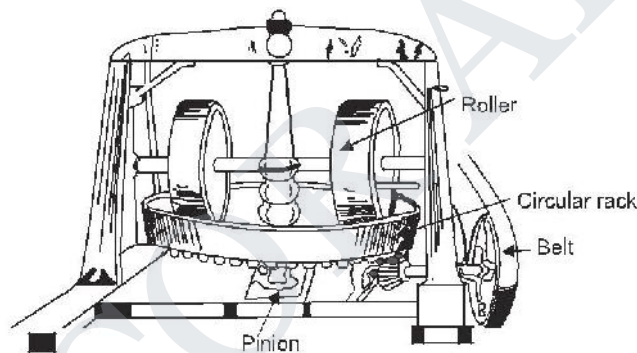

Fig. 20 Power Driven Mortar Mill (Pan Mill)

Precautions Lime mortar or putty should be kept moist till use and in no case its drying is allowed. The mortar made of hydraulic lime should be consumed within one day and that with fat lime within 2-3 days.

2.2 Composition Of Cement Clinker

The various constituents combine in burning and form cement clinker. The compounds formed in the burning process have the properties of setting and hardening in the presence of water. They are known as Bogue compounds after the name of Bogue who identified them. Le-Chatelier and Tornebohm have referred these compounds as Alite (C_3S), Belite (C_2S), Celite (C_3A) and Felite (C_4AF). The following Bogue compounds are formed during clinkering process.

The properties of Portland cement varies markedly with the proportions of the above four compounds, reflecting substantial difference between their individual behaviour.

Tricalcium Silicate is supposed to be the best cementing material and is well burnt cement. It is about 25-50% (normally about 40 per cent) of cement. It renders the clinker easier to grind, increases resistance to freezing and thawing, hydrates rapidly generating high heat and develops an early hardness and strength. However, raising of C_3S content beyond the specified limits increases the heat of hydration and solubility of cement in water. The hydrolysis of C_3S is mainly responsible for 7 day strength and hardness. The rate of hydrolysis of C_3S and the character of gel developed are the main causes of the hardness and early strength of cement paste. The heat of hydration is 500 J/g.

Dicalcium Silicate is about 25-40% (normally about 32 per cent) of cement. It hydrates and hardens slowly and takes long time to add to the strength (after a year or more). It imparts resistance to chemical attack. Raising of C_2S content renders clinker harder to grind, reduces early strength, decreases resistance to freezing and thawing at early ages and decreases heat of hydration. The hydrolysis of C_2S proceeds slowly. At early ages, less than a month, C_2S has little influence on strength and hardness. While after one year, its contribution to the strength and hardness is proportionately almost equal to C_3S . The heat of hydration is 260 J/g.

Tricalcium Aluminate is about 5-11% (normally about 10.5 per cent) of cement. It rapidly reacts with water and is responsible for flash set of finely grounded clinker. The rapidity of action is regulated by the addition of 2-3% of gypsum at the time of grinding cement. Tricalcium aluminate is responsible for the initial set, high heat of hydration and has greater tendency to volume changes causing cracking. Raising the C_3A content reduces the setting time, weakens resistance to sulphate attack and lowers the ultimate strength, heat of hydration and contraction during air hardening. The heat of hydration of 865 J/g.

Tetracalcium Almino Ferrite is about 8-14% (normally about 9 per cent) of cement. It is responsible for flash set but generates less heat. It has poorest cementing value. Raising the C_4AF content reduces the strength slightly. The heat of hydration is 420 J/g.

Calculation of Compound Composition of Portland Cement: Bogue developed a method for calculating the compound composition from the oxide analysis of a cement. This method is based upon cooling of the clinker at such rate that equilibrium is maintained. Although equilibrium does not usually obtain in commercial operations, valuable information can be derived from such calculations. The method is summarized in the following steps and in Table 5. An accurate chemical analysis is entered in the first column of the table as shown.

Table 5 Record of Significant Data for Computing Compound Composition

Oxides	Analysis	Compounds					
		Free CaO	SO ₃ +	Fe ₂ O ₃ +	Al ₂ O ₃ +	c and s	C ₂ S and C ₄
CaO	63.0	0.2	c ₁ =1.0	c ₂ =4.9	c ₃ =5.4	c=51.5	c ₄ =10.3
MgO	3.0						
Al ₂ O ₃	5.5	a ₁ =2.2	a ₂ =3.3		
Fe ₂ O ₃	3.5	3.5			
SiO ₂	22.0	s=22.0	63.2 approx.
SO ₃	1.5	1.5				
Ig. Loss	1.2						
Ins. Res.	0.1						
Free CaO	0.2						
Ignition Loss	Free MgO	Free CaO	CaSO ₄	C ₄ AF	C ₃ A	C ₃ S	C ₂ S
1.2	3.0	0.2	2.5	10.6	8.7	42	32

Since the ratio of the atomic weight of CaO : SO₃ = 56.07 : 80.065 = 0.70:1, each percentage of SO₃ combines with 0.70 per cent of CaO to form 1.70 per cent of CaSO₄. Hence, the percentage of lime required to satisfy SO₃ (= 0.7 × per cent SO₃) is recorded as c₁ in column 4 of the table, opposite CaO; the percentage of SO₃ is also entered in column 4; and the CaSO₄ content is summed and entered at the bottom of column 4.

Similarly, since the atomic ratios $\text{Al}_2\text{O}_3 : \text{Fe}_2\text{O}_3 = 101.92 : 159.68 = 0.64 : 1$ and $4\text{CaO} : \text{Fe}_2\text{O}_3 = 224.28 : 159.68 = 1.40 : 1$, it is evident that each percentage of Fe_2O_3 enters into combination with 0.64 per cent of Al_2O_3 and 1.40 per cent of CaO to form 3.04 per cent of $4\text{CaO} \times \text{Al}_2\text{O}_3 \times \text{Fe}_2\text{O}_3$. Therefore $0.64 \times$ percentage of Fe_2O_3 is entered as a_1 , opposite Al_2O_3 in column 5, and $1.4 \times$ percentage of Fe_2O_3 is entered as c_2 , opposite CaO in column 5; the percentage of Fe_2O_3 is re-entered in the same column; and the percentage of C_4AF is summed at the bottom.

Since practically none of the magnesia is combined, it is entered as free at the bottom of column 2.

The total alumina minus a_1 , entered as a_2 in column 6, is available to combine with lime to form C_3A in the ratio $3\text{CaO} : \text{Al}_2\text{O}_3 = 168.21 : 101.92$ is $1.65 : 1$. Hence, each percentage of this available alumina $\times 1.65$ is the percentage of CaO required for C_3A , and it is entered opposite CaO as c_3 in column 6. Summing quantities in column 6 gives percentage of C_3A .

The CaO available to combine with SiO_2 is total CaO minus (free $\text{CaO} + c_1 + c_2 + c_3$); call this difference c . Then the total silica (s) is calculated first to combine with CaO to form C_2S . Since the ratio $2\text{CaO} \times \text{SiO}_2 : \text{SiO}_2 = 172.20 : 60.06 = 2.87:1$, each percentage of $s \times 2.87$ is the percentage of C_2S . This first approximation of C_2S is entered in column 8, opposite SiO_2 . By subtracting this value of C_2S from the sum $s + c$, the amount of CaO (called c_4) available for combination with $2\text{CaO} \times \text{SiO}_2$ to form $3\text{CaO} \times \text{SiO}_2$ is determined. Since the ratio $3\text{CaO} \times \text{SiO}_2 : \text{CaO} = 228.27 : 56.07 = 4.07:1$, multiplying c_4 by 4.07 gives the amount of C_3S which is entered at the foot of column 7. By subtracting this value of C_3S from $c + s$, the true percentage of C_2S is found and entered in column 8.

Should the computed percentage of C_3S be greater than $c + s$, no C_2S is present. In that case the content of C_3S is found from the ratio $3\text{CaO} \times \text{SiO}_2 : \text{SiO}_2 = 228.27 : 60.06 = 3.8 : 1$. Hence, the percentage of C_3S is obtained by multiplying the percentage of SiO_2 by 3.8. This latter value of C_3S , subtracted from $c + s$, gives the percentage of uncombined lime. This last condition can only be obtained when lime is in excess of the amount required for equilibrium and the free lime has not been deducted.

Since errors in chemical analysis of 0.2 per cent in determinations of lime, alumina, silica, or iron oxide will make errors up to 1.5 per cent in certain compounds, percentages for the compounds should be rounded off to whole numbers. If the ignition loss is high, the analysis should be reduced to a clinker basis prior to compound calculations.

As previously mentioned, Bogue's method of calculation is based on the assumption that the clinker is slowly cooled at such rate that equilibrium is maintained and the crystallization is complete. Lea and Parker have shown that values calculated by the bogue method may be considerably in error if the clinker liquid crystallizes independently of the solids formed, or if cooling is so sudden that no crystallization takes place and glass is formed. For the case of independent crystallization and a clinkering temperature of 1400°C , they show that Bogue's method is correct for cements with $\text{Al}_2\text{O}_3/\text{Fe}_2\text{O}_3$ ratios between 0.9 and 1.7, but for ratios between 1.7 and 6.1 their corrections to be added are :

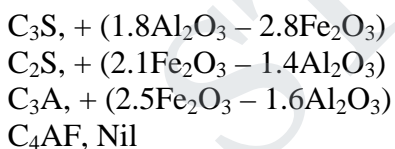

Thus for a cement with $\text{Al}_2\text{O}_3 = 7$ and $\text{Fe}_2\text{O}_3 = 3$ per cent, the correction to $\text{C}_3\text{S} = 4.2$, to $\text{C}_2\text{S} = -3.5$, and to $\text{C}_3\text{A} = -3.7$ per cent.

For very rapid cooling of the clinker, the liquid is formed into glass and they show that no C_3A or C_4AF appear but the amount of glass is $+ (2.95\text{Al}_2\text{O}_3 + 2.2\text{Fe}_2\text{O}_3)$. For this case their corrections to Bogue's values for C_3S and C_2S are: $\text{C}_3\text{S}, + (1.8\text{Al}_2\text{O}_3 - 2.8\text{Fe}_2\text{O}_3)$; $\text{C}_2\text{S} + (1.9\text{Fe}_2\text{O}_3 - 2.1\text{Al}_2\text{O}_3)$.

The chemical reaction between cement and water is known as hydration of cement. The reaction takes place between the active components of cement (C_4AF , C_3A , C_3S and C_2S) and water. The factors responsible for the physical properties of concrete are the extent of hydration of cement and the resultant microstructure of the hydrated cement. When the cement comes in contact with water, the hydration products start depositing on the outer periphery of the nucleus of hydrated cement. This reaction proceeds slowly for 2-5 hours and is called induction or dormant period. As the hydration proceeds, the deposit of hydration products on the original cement grain makes the diffusion of water to unhydrated nucleus more and more difficult, consequently reducing the rate of hydration with time. At any stage of hydration, the cement paste consists of gel (a fine-grained product of hydration having large surface area collectively), the unreacted cement, calcium hydroxide, water and some minor compounds.

The crystals of the various resulting compounds gradually fill the space originally occupied by water, resulting in the stiffening of the mass and subsequent development of the strength. The reactions of the compounds and their products are as follows:

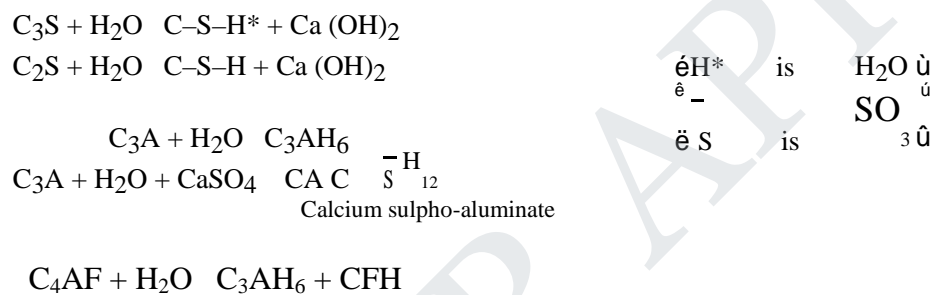

The product $C-S-H$ gel represents the calcium silicate hydrate also known as tobermorite gel which is the gel structure. The hydrated crystals are extremely small, fibrous, platy or tubular in shape varying from less than 2 nm to 10 nm or more. The $C-S-H$ phase makes up 50–60% of the volume of solids in a completely hydrated Portland cement paste and is, therefore, the most important in determining the properties of the paste. The proposed surface area for $C-S-H$ is of the order of 100–700 m^2/g and the solid to solid distance being about 18 Å. The $Ca(OH)_2$ liberated during the silicate phase crystallizes in the available free space. The calcium hydroxide crystals also known as portlandite consists of 20–25% volume of the solids in the hydrated paste. These have lower surface area and their strength contributing potential is limited. The gel must be saturated with water if hydration is to continue. The calcium hydroxide crystals formed in the process dissolve in water providing hydroxyl (OH^-) ions, which are important for the protection of reinforcement in concrete. As hydration proceeds, the two crystal types become more heavily interlocked increasing the strength, though the main cementing action is provided by the gel which occupies two-thirds of the total mass of hydrate.

Notes : 1. It has been found that hydration of C_3S produces lesser calcium silicate hydrate and more $Ca(OH)_2$ as compared to the hydration of C_2S . Since $Ca(OH)_2$ is soluble in water and leaches out making the concrete porous, particularly in hydraulic structures, a cement with small percentage of C_3S and more C_2S is recommended for use in hydraulic structures.

2. It is particularly important to note that the setting (the change of cement paste from plastic to stiff solid state) and hardening (gain of strength with hydration is a chemical reaction, wherein water plays an important role, and is not just a matter of drying out. Infact, setting and hardening stop as soon as the concrete becomes dry.

The reaction of compound C A with water is very fast and is responsible for flash setting of cement (stiffening without strength development) and thus it will prevent the hydration of C S and C S. However, calcium sulphate (CaSO) present in the clinker dissolves immediately in water and forms insoluble calcium sulphoaluminate. It deposits on the surface of C A forming a colloidal membrane and consequently retards the hydration of C A. The amount of CaSO is adjusted to leave a little excess of C A to hydrate directly. This membrane in the process breaks because of the pressure of the compounds formed during hydration and then again C A becomes active in the reaction.

The hardening of C S can be said to be catalyzed by C A and C S becomes solely responsible for gain of strength up to 28 days by growth and interlocking of C-S-H gel. The increase in strength at later age is due to hydration of C S.

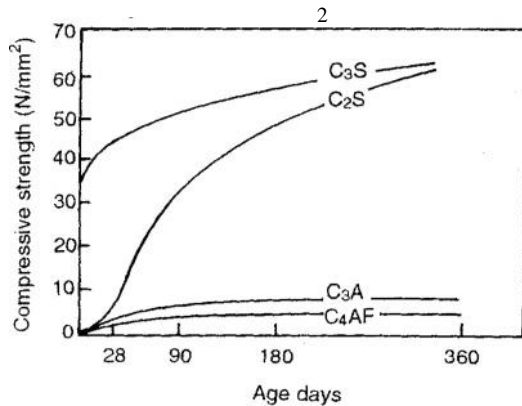

Fig. 21 Contribution of Cement Compounds to Strength of Cement

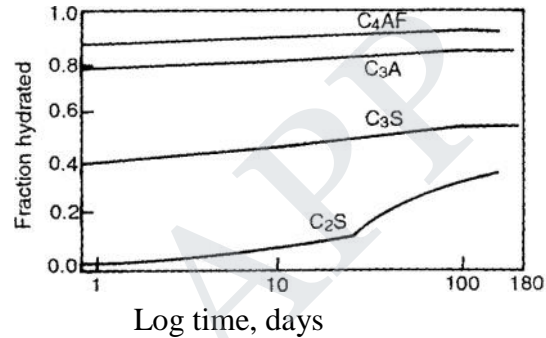

Fig. 22 Rate of Hydration of Pure Cement Compounds

Notes: 1. The development of strength of the four principal compounds of cement with age is shown in Fig. 21

2. The rate of heat evolution of the compounds if equal amount of each is considered will be in the following descending order:

C₃A, C₃S, C₄AF, C₂S

3. The rate of hydration is increased by an increase in fineness of cement. However, total heat evolved is the same. The rate of hydration of the principal compounds is shown in Fig. 5.2 and will be in the following descending order:

C₄AF, C₃A, C₃S, C₂S

2.5 Manufacture Of Cement

Calcareous and argillaceous raw materials are used in the manufacture of Portland cement. The calcareous materials used are cement rock, limestone, marl, chalk and marine shell. The argillaceous materials consist of silicates of alumina in the form of clay, shale, slate and blast furnace slag.

From the above materials, others like lime, silica, alumina, iron oxide and small quantities of other chemicals are obtained. Cement can be manufactured either by dry process or wet process.

Dry Process

The dry process is adopted when the raw materials are quite hard. The process is slow and the product is costly. Limestone and clay are ground to fine powder separately and are mixed. Water is added to make a thick paste. The cakes of this paste, which contain about 14 per cent of moisture, are dried and are charged into rotary kiln (Fig. 23). The product obtained after calcination in rotary kiln is called clinker. The clinker is obtained as a

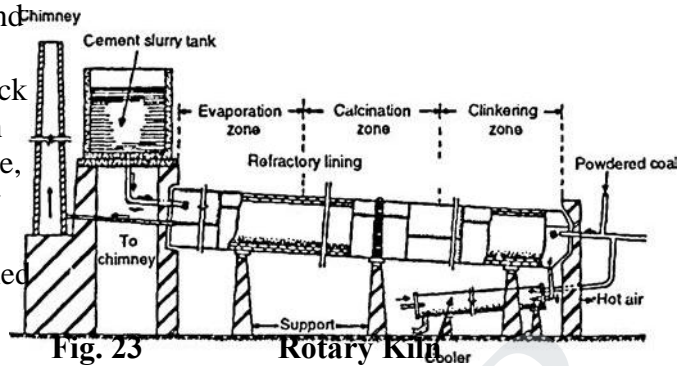

Fig. 23

Rotary Kiln

result of incipient fusion and sintering at a temperature of about 1400°-1500°C. Because ferric oxide has lower melting point than the other oxides, it acts as a flux. Aeration of cement clinker, which is commonly practised to slake free lime, also causes an absorption of some moisture and carbon dioxide. Absorption of moisture tends to decrease the setting whereas that of carbon dioxide accelerates setting. The clinker is cooled rapidly to preserve the



Fig. 24

Rotary Kiln

metastable compounds and their solid solutions — dispersion of one solid in another — which are made as the clinker is heated. Clinker is then cooled and ground in tube mills (Fig. 24),

where 2-3% of gypsum is added. Generally, cement is stored in bags of 50 kg. A flow diagram of dry process is shown in Fig. 25. The purpose of adding gypsum is to coat the cement particles by interfering with the process of hydration of the cement particles. This retards the setting of cement.

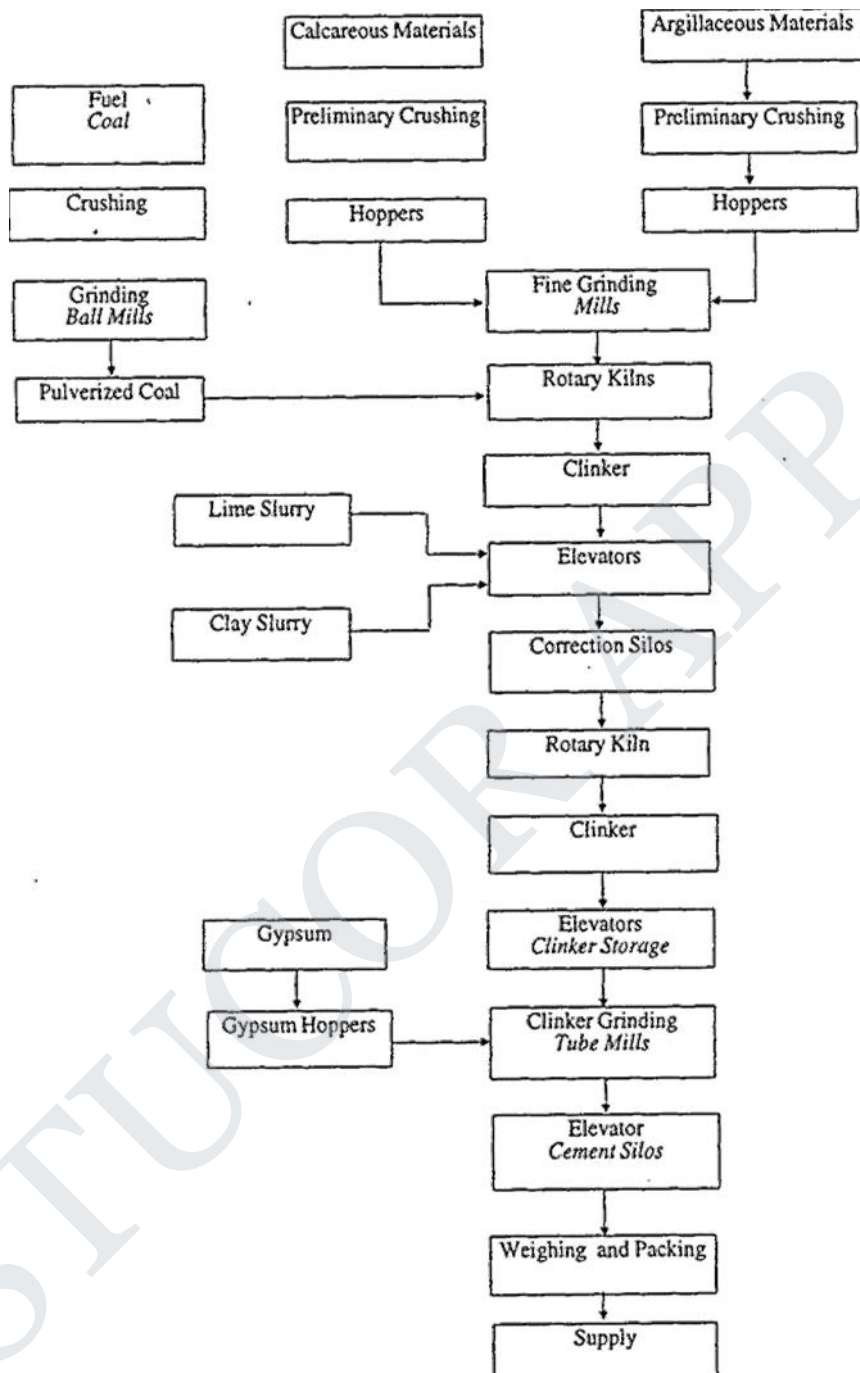
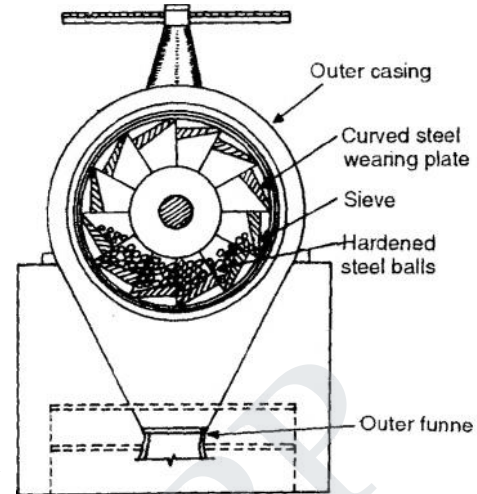

Fig. 5.5 Flow Diagram of Cement Manufacture—Dry Process

The operations in the wet process of cement manufacture are mixing, burning and grinding. The crushed raw materials are fed into ball mill (Fig. 26) and a little water is added. On operating the ball mill, the steel balls in it pulverize the raw materials which form a slurry with water. This slurry is passed to silos (storage tanks), where the proportioning of the compounds is adjusted to ensure desired chemical composition. The corrected slurry having about 40 per cent moisture content, is then fed into rotary kiln (Fig. 24) where it loses moisture and forms into lumps or nodules. These are finally burned at 1500-1600°C. The nodules change to clinker at this temperature. Clinker is cooled and then ground in tube mills. While grinding the clinker, about 3 per cent gypsum is added. The cement is then stored in silos from where it is supplied. A flow diagram of manufacturing cement by wet process is shown in Fig. 27.



. 26 Ball Mill

Comparison of Wet and Dry Process: The chief advantages of the wet process are the low cost of excavating and grinding raw materials, the accurate control of composition and homogeneity of the slurry, and the economical utilization of fuel through the elimination of separated drying operations. On the other hand the longer kilns, essential in the wet process, cost more and are less responsive to a variable clinker demand than the short kilns which can be used in the dry process.

2.6 Testing Of Cement

Experience has shown that it is practically impossible to make large quantities of cement without any variation in quality. To be sure, some mills working with raw materials which run very uniformly and using the best of equipment and methods of operation will have very few unsuccessful 'burns' in a year, whereas others will be less fortunate. Nevertheless the consumer has little chance of ascertaining how his particular consignment of cement was made; therefore, if he has under way a construction of any importance, he ought to satisfy himself regarding the quality of his purchase. He should test his cement not only to see that he gets what he has paid for but also to forestall the possibility of a failure through the use of defective material.

In engineering construction the main qualifications demanded of a cement are permanency of structure, strength, and a rate of setting suitable to the demands of the work. To determine these qualifications, both physical and chemical tests are made, the former, on account of importance, more often than the latter.

As a result of long experience the physical tests which have come into general use in determining the acceptability of cement are: (1) soundness or constancy of volume, (2) strength, (3) time of set or activity, and (4) fineness. In order that the results of such tests made by different parties may accord as nearly as possible, it is necessary that a standard method be rigidly adhered to and that only experienced operators, who fully appreciate the necessity of eliminating personal equation from all manipulations, be employed.

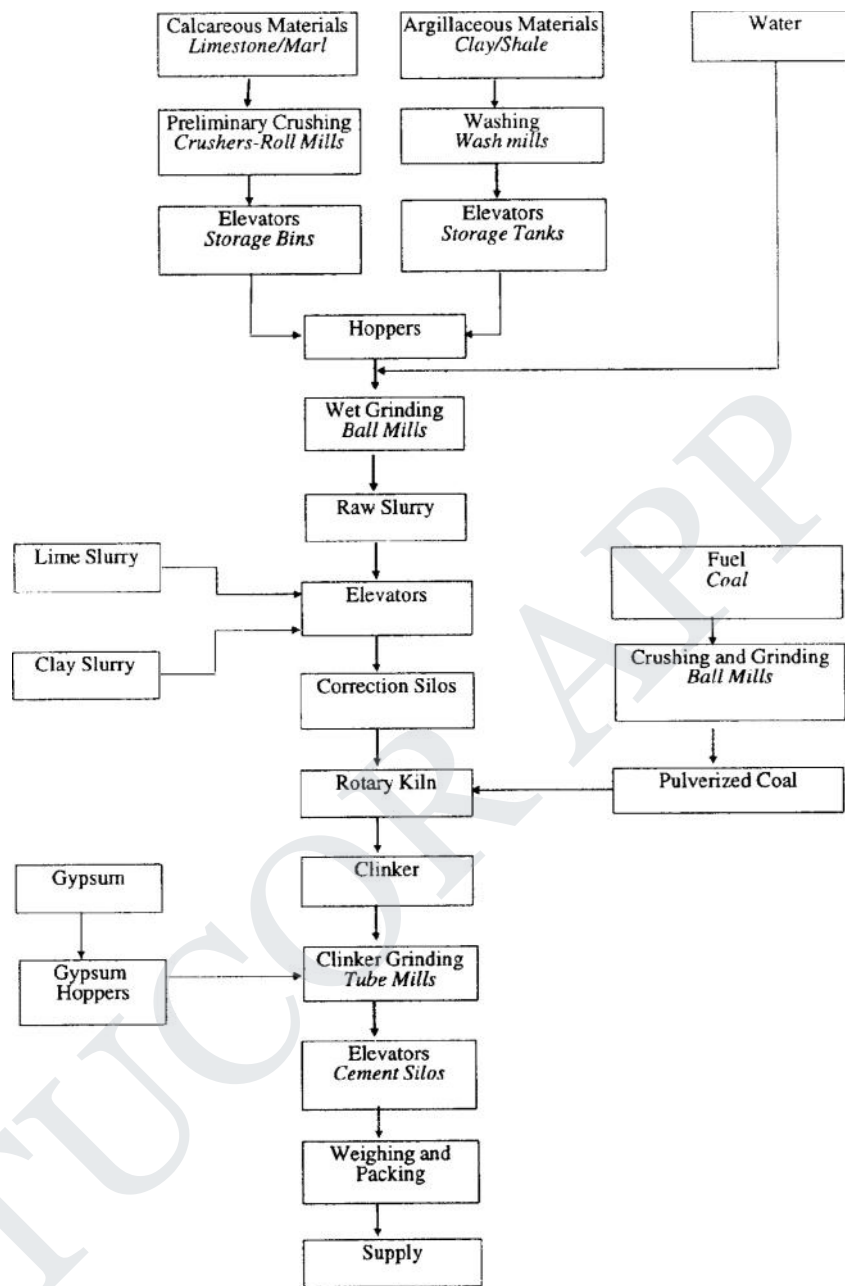

● Fig. 27 Flow Diagram of Cement Manufacture—Wet Process

Physical Tests (IS: 4031) Fineness

Test

The degree of fineness of cement is the measure of the mean size of the grains in it. There are three methods for testing fineness: the sieve method—using 90 micron (9 No.) sieve, the air permeability method—Nurse and Blains method and the sedimentation method—Wagner turbidimeter method. The last two methods measure the surface area, whereas the first measures grain size. Since cement grains are finer than 90 micron, the sieve analysis method does not represent true mean size of cement grains. Also, the tiny cement grains tend to conglomerate into lumps resulting in distortion in the final grain size distribution curves. Considering these demerits, fineness is generally expressed in terms of specific area, which is the total surface area of the particles in unit weight of material.

Conditions Affecting Fineness: The chemical composition and the degree of calcination influence the hardness of the clinker and consequently the fineness to which the cement is ground. Clinker, high in iron or silica, is apt to be hard and difficult to grind. The same is true with a hard-burned clinker. Fineness is also influenced by the time of grinding and the character of the pulverizing machinery. It has been found that cement becomes finer with age provided it does not absorb too much moisture. This is probably due to the decrepitation of the coarser grains resulting from the hydration of the embedded lime particles.

Importance: Finer the cement, more is the strength since surface area for hydration will be large. With increase in fineness, the early development of strength is enhanced but the ultimate strength is not affected. An increase in the fineness of the cement increases the cohesiveness of the concrete mix and thus reduces the amount of water which separates to the top of a lift (bleeding), particularly while compacting with vibrators. However, if the cement is ground beyond a certain limit, its cementative properties are affected due to the prehydration by atmospheric moisture. Finer cement reacts more strongly in alkali reactive aggregate. Also, the water requirement and workability will be more leading to higher drying shrinkage and cracking.

Sieve Method: 100 g of cement sample is taken and air-set lumps, if any, in the sample are broken with fingers. The sample is placed on a 90 micron sieve and continuously sieved for 15 minutes. The residue should not exceed the limits specified below:

Type of cement	Percentage of residue by weight	Specific surface (m ² /kg) not less than
1. Ordinary Portland Cement (OPC)	225	
2. Rapid Hardening Cement (RHC)	325	
3. Portland Pozzolana Cement (PPC)	300	

Air Permeability Method: The fineness of cement is represented by specific surface, i.e. total surface area in cm² per gram or m² per kilogram of cement and is measured by Lea and Nurse apparatus or by wagner turbidimeter..

The Lea and Nurse apparatus shown in Fig. 28 essentially consists of a permeability test cell—where cement is placed and air pressure is applied, flowmeter—to determine the quantity of air passing per second through its capillary tube per unit difference of pressure, and manometer—to measure the air pressure.

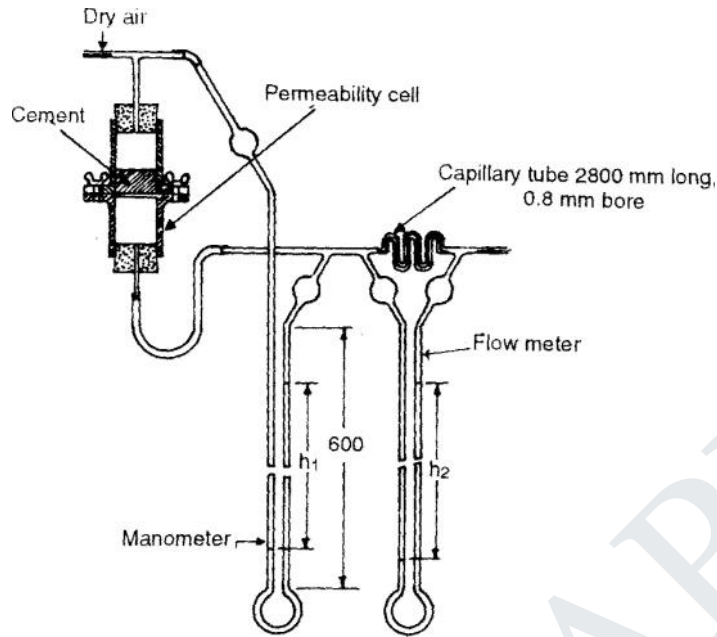

Fig. 28 Permeability Apparatus

To determine the fineness, a cement sample of 20 mm height is placed on a perforated plate (40 micron perforations) and air pressure is applied. The manometer is connected to the top of the permeability cell and the air is turned on. The lower end of the permeability cell is then slowly connected to the other end of the manometer. The rate of flow is so adjusted that the flowmeter shows a pressure difference (h_2) of 30-50 cm. The reading (h_1) in the manometer is recorded. The process is repeated till the ratio h_1/h_2 is constant. The specific surface is given by the expression

$$S = \frac{14}{d(1 - Y)} \sqrt{\frac{A}{KL}} \sqrt{\frac{h_1}{h_2}}$$

- where
- L = thickness of cement layer
 - A = area of cement layer
 - d = density of cement
 - Y = porosity of cement (0.475)
 - h_2 = flowmeter reading
 - h_1 = manometer reading

K is the flowmeter constant and is obtained by

$$Q = \frac{K h_2 d_1}{\mu}$$

- where
- μ = viscosity of air
 - d_1 = density of kerosene
 - Q = quantity of air passed per second

The minimum specific surface for various cements should be as specified in Table 6.

Table 6 Minimum Specific Surfaces of Cements

Type of cement		Specific surface not less than cm ² /g
Ordinary Portland Cement	(OPC)	2250
Rapid Hardening Cement	(RHC)	3250
Low Heat Cement	(LHC)	3250
Portland Puzzolana Cement	(PPC)	3000
High Alumina Cement	(HAC)	2250
Super Sulphate Cement	(SSC)	4000

Wagner Turbidimeter Method: L.A.Wagner developed a turbidimeter to estimate the surface area of one gram of cement. The cement is dispersed uniformly in a rectangular glass tank filled with kerosene. Then, parallel light rays are passed through the solution which strike the sensitivity plate of a photoelectric cell. The turbidity of the solution at a given instant is measured by taking readings of the current generated by the cell. By recording the readings at regular intervals while the particles are falling in the solution, it is possible to secure information regarding the grading in surface area and in size of particle. Readings are expressed in sq. cm per gram.

Consistency Test

This is a test to estimate the quantity of mixing water to form a paste of normal consistency defined as that percentage water requirement of the cement paste, the viscosity of which will be such that the Vicat’s plunger penetrates up to a point 5 to 7 mm from the bottom of the Vicat’s mould.

Importance: The water requirement for various tests of cement depends on the normal consistency of the cement, which itself depends upon the compound composition and fineness of the cement.

Test Procedure: 300 g of cement is mixed with 25 per cent water. The paste is filled in the mould of Vicat’s apparatus (Fig. 29) and the surface of the filled paste is smoothed and levelled. A square needle 10 mm x 10 mm attached to the plunger is then lowered gently over the cement paste surface and is released quickly. The plunger pierces the cement paste. The reading on the attached scale is recorded. When the reading is 5-7 mm from the bottom of the mould, the amount of water added is considered to be the correct percentage of water for normal consistency.

Determination of Initial and Final Setting Times

When water is added to cement, the resulting paste starts to stiffen and gain strength and lose the consistency simultaneously. The term setting implies solidification of the plastic cement

paste. Initial and final setting times may be regarded as the two stiffening states of the cement. The beginning of solidification, called the initial set, marks the point in time when the paste has become unworkable. The time taken to solidify completely marks the final set, which should not be too long in order to resume construction activity within a reasonable time after the placement of concrete. Vicat’s apparatus used for the purpose is shown in Fig.. The initial setting time may be defined as the time taken by the paste to stiffen to such an extent that the Vicat’s needle is

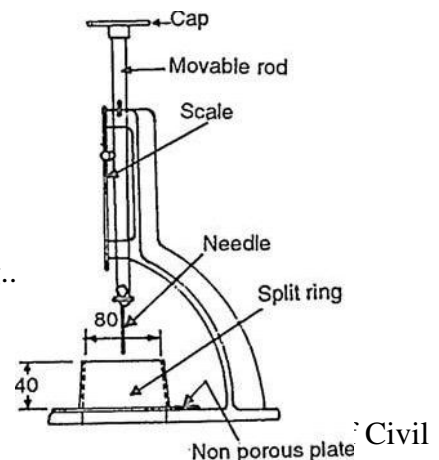

not permitted to move down through the paste to within 5 ± 0.5 mm measured from the bottom of the mould. The final setting time is the time after which the paste becomes so hard that the angular attachment to the needle, under standard weight, fails to leave any mark on the hardened concrete. Initial and final setting times are the rheological properties of cement.

Importance: It is important to know the initial setting time, because of loss of useful properties of cement if the cement mortar or concrete is placed in moulds after this time. The importance of final setting time lies in the fact that the moulds can be removed after this time. The former defines the limit of handling and the latter defines the beginning of development of mechanical strength.

Conditions Affecting Setting Time: The factors influencing the setting properties of cement are its composition, the percentage of retardant, degree of calcination, fineness of grinding, aeration subsequent to grinding clinker, percentage of water used to make cement paste, the temperature of the mixing water, cement and the atmosphere where the cement paste is placed, and the amount of manipulation the paste receives. The effect of lime, silica and alumina in controlling the set have been discussed in Sec. 5.3. The effect of gypsum is to increase the setting time of freshly ground cement. It is usually mixed with the clinker before final grinding, or just after the clinker has received preliminary grinding. The addition of gypsum before calcination causes it to decompose into lime and sulphur trioxide. Since the latter is liberated in the kiln, there is resulting effect on the setting time. Often, an underlimed cement becomes quick setting after seasoning. This can be avoided by adding to the cement 1 or 2 per cent of hydrated lime or the fraction of a per cent of Plaster of Paris. Setting time of cement is rapid with the increase in the fineness of cement. When the mixing water used in testing cement paste is increased by 1 per cent above that required for normal consistency, an increase of about 30 minutes or more is observed in the initial or final set.

Cements stored in warm rooms will, in general, be quick setting than those stored in cold places. Cold mixing water retards set while warm water accelerates it. Cement exposed to thoroughly saturated atmosphere will set much more slowly than those exposed to a dry atmosphere. If, however, a considerable proportion of moist CO_2 is present in the air, the setting time is found to reduce greatly. By lengthening the time of mixing and by prolonged troweling of the surface mortars, it is also possible to considerably delay the setting time.

Test Procedure: A neat cement paste is prepared by gauging cement with 0.85 times the water required to give a paste of standard consistency. The stop watch is started at the instant water is added to the cement. The mould resting on a nonporous plate is filled completely with cement paste and the surface of filled paste is levelled smooth with the top of the mould. The test is conducted at room temperature of $27 \pm 2^\circ\text{C}$. The mould with the cement paste is placed in the Vicat's apparatus as shown in Fig. 5.9 and the needle is lowered gently in contact with the test block and is then quickly released. The needle thus penetrates the test block and the reading on the Vicat's apparatus graduated scale is recorded. The procedure is repeated until the needle fails to pierce the block by about 5 mm measured from the bottom of the mould. The stop watch is pushed off and the time is recorded which gives the initial setting time.

The cement is considered to be finally set when upon applying the needle gently to the surface of test block, the needle makes an impression, but the attachment fails to do so.

It is essential that the cement concrete does not undergo large change in volume after setting. This is ensured by limiting the quantities of free lime and magnesia which slake slowly causing change in volume of cement (known as unsound). Soundness of cement may be tested by Le-Chatelier method or by autoclave method. For OPC, RHC, LHC and PPC it is limited to 10 mm, whereas for HAC and SSC it should not exceed 5 mm.

Importance: It is a very important test to assure the quality of cement since an unsound cement produces cracks, distortion and disintegration, ultimately leading to failure.

Conditions Affecting Soundness: The main cause for unsoundness in Portland cement is the hydration of the uncombined lime encased within the cement particles. Exposed, finely ground, free lime in small percentages, hydrates before the cement sets and produces no injurious effect. The uncombined lime in cement is a result of either underburning the clinker or of excess lime in the raw materials. Freshly ground cement is often unsound due to the presence of uncombined lime. Cement is thus allowed to aerate for two to three weeks, allowing the lime to hydrate, to overcome unsoundness.

Fine grinding of the raw material and clinker help to produce a sound cement. By grinding fine the raw materials, it is possible to produce a homogeneous mixture before burning where the lime is uniformly distributed. The coarse grains of cement may imprison minute particles of uncombined lime which do not hydrate. These lime particles on hydration produce disintegration.

Le-chatelier Method:

filled with neat cement paste formed by gauging 100 g cement with 0.78 times the water required to give a paste of standard consistency. The mould is covered with a glass sheet and a small weight is placed on the covering glass sheet. The mould is then submerged in the water at temperature of 27°-32° C. After 24 hours, the mould is taken out and the distance separating the indicator points is measured. The mould is again submerged in water. The water is now boiled for 3 hours. The mould is removed from water and is cooled down. The distance between the indicator points is measured again. The difference between the two measurements represents the unsoundness of cement.

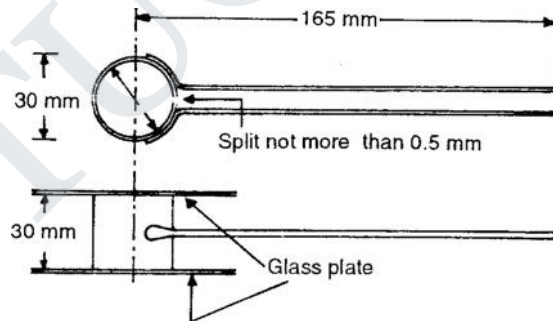

Fig. 30 Le-chatelier Apparatus

Autoclave Test:

moulded specimen is removed from the moist atmosphere, measured for length, and so placed in an autoclave at room temperature that the four tides of each specimen are at least exposed to saturated steam. The temperature of the autoclave is raised at such a rate that the gauge pressure of the steam rises to 2.1

2

at the end of the hour. The autoclave is then opened and the test specimens are placed in water at temperature of 90°C. The temperature is gradually brought down to 27±2°C in 15 minutes. The specimens are maintained at this temperature for the first 15 minutes and one The pressure is The height of the spurs. This the heat supply. The difference in the autoclave is calculated as given at the bottom of the sheet. 0.1N/mm

2

Determination of Strength

Cement hydrates when water is added to it and cohesion and solidity is exhibited. It binds together the aggregates by adhesion. The strength of mortar and concrete depends upon the type and nature of cement. So, it should develop a minimum specified strength if it is to be used in structures. Cement is tested for compressive and tensile strengths.

Conditions Affecting Strength: Cement is very strong at early ages if a high lime or high alumina content is there. Gypsum and Plaster of Paris in small percentages also tend to increase the strength slightly, but when present in quantities larger than 3 per cent, these substances provide variable effects. The effect of the clinker compounds on strength have already been discussed. In addition to the effect of composition, the strength of cement is greatly influenced by the degree of burning, the fineness of grinding, and the aeration it receives subsequent to final grinding. An underburnt cement is likely to be deficient in strength.

Compressive Strength:

quality and the quantity of concrete can be controlled and the degree of adulteration can be checked.

The test specimens are 70.6 mm cubes having face area of about 5000 sq. mm. Large size specimen cubes cannot be made since cement shrinks and cracks may develop. The temperature of water and test room should be 27±2°C. A mixture of cement and standard sand in the proportion 1:3 by weight is mixed dry with a trowel for one minute and then with water until the mixture is of uniform colour. Three specimen cubes are prepared. The material for each cube is mixed separately. The quantities of cement, standard sand and water are 185 g, 555 g and (P/4) + 3.5, respectively where P = percentage of water required to produce a paste of standard consistency. The mould is filled completely with the cement paste and is placed on the vibration table. Vibrations are imparted for about 2 minutes at a speed of 12000±400 per minute.

The cubes are then removed from the moulds and submerged in clean fresh water and are taken out just prior to testing in a compression testing machine. Compressive strength is taken to be the average of the results of the three cubes. The load is applied starting from zero at a rate of 35 N/sq mm/minute. The compressive strength is calculated from the crushing load divided by the average area over which the load

2

given in Table 5.4.

Table 7 Minimum Specified Strength in N/mm

is applied. The result is expressed in N/mm . The minimum specified strength for some of the cements is

Type/Days	1 day	3 days	7 days	28 days
inary Portland cement (33 grade)		16.0	22.0	33.0

Portland Puzzolana cement	-	16.0	22.0	33.0
Low heat Portland cement	-	10.0	16.0	35.0
Rapid hardening cement	16.0	27.5	-	-
High alumina cement	30.0	35.0	-	-

Tensile Strength: The tensile strength may be determined by Briquette test method or by split tensile strength test.

Importance: The tensile strength of cement affords quicker indications of defects in the cement than any other test. Also, the test is more conveniently made than the compressive strength test. Moreover, since the flexural strength, is directly related to the tensile strength this test is ideally fitted to give information both with regard to tensile and compressive strengths when the supply for material testing is small.

Briquette Method: A mixture of cement and sand is gauged in the proportion of 1:3 by weight. The percentage of water to be used is calculated from the formula $(P/5) + 2.5$, where P = percentage of water required to produce a paste of standard consistency. The temperature of the water and the test room should be $27^{\circ} \pm 2^{\circ}\text{C}$. The mix is filled in the moulds of the shape shown in Fig. 5.11.

After filling the mould, an additional heap of mix is placed on the mould and is pushed down with the standard spatula, until the mixture is level with the top of the mould. This operation is repeated on the other side of the mould also. The briquettes in the mould are finished by smoothing the surface with the blade of a trowel. They are then kept for 24 hours at a temperature of $27^{\circ} \pm 2^{\circ}\text{C}$ and in an atmosphere having 90 per cent humidity. The briquettes are then kept in clean fresh water and are taken out before testing. Six briquettes are tested and the average tensile strength is calculated. Load is applied steadily and uniformly, starting from zero and increasing at the rate of 0.7 N/sq mm of section in 12 seconds.

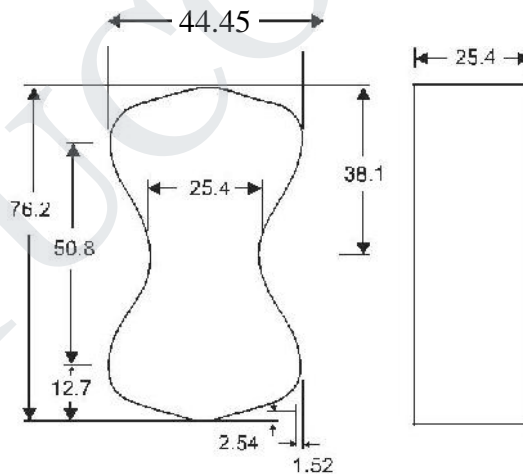

Fig. 31 Dimensions of Standard Briquette

Ordinary Portland cement should have a tensile strength of not less than 2.0 N/mm^2 after 3 days and not less than 2.5 N/mm^2 after 7 days.

- Notes:**
- (i) In the tension test of cement the load on the briquette should be applied centrally. Since briquettes become brittle with age, the effect of slight eccentricity or any torsional strain is pronounced in long-time tests.
 - (ii) The strength increases when the loading rate is increased from that specified.

Heat of hydration

Heat is evolved during hydration of cement, the amount being dependent on the relative quantities of the clinker compounds.

Importance: The evolution of heat causes an increase in temperature of the concrete, being greatest in mass concreting. Since the cooling of a mass of concrete can only occur from surfaces exposed to atmosphere the temperature of the interior is higher than that at the surface and also there is a rapid increase in strength in the interior than at the surface. Shrinkage cracks may result from stresses, induced by cooling of the surface while the interior of concrete is still at higher temperature. However, in practice, the heat evolution may be taken to its advantage in cold weather provided the concrete is warm at the time of placing and excessive heat loss is prevented by suitable lagging.

Test Procedure: The apparatus used to determine the heat of hydration of cement is known as calorimeter and is shown in Fig. 32. 60 g of cement and 24 ml of distilled water are mixed for 4 minutes at temperature 15°–

and sealed with wax. The vials are then stored with the mixture in a vertical position at 27°±2° C. The heat of hydration is obtained by subtracting the respective heat of solution of unhydrated cement calculated nearest to 0.1 calorie.

For determining the heat of solution of unhydrated cement, weigh a sample of about 3 g. At the same time, weigh out 7.0 g of cement for the loss on ignition.

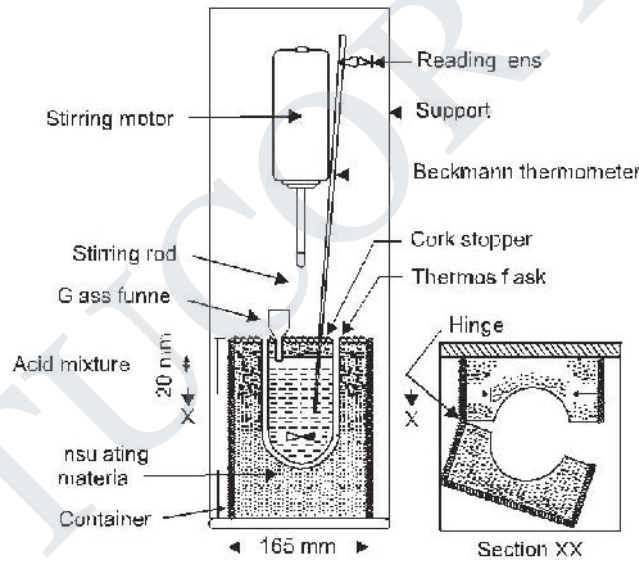

Fig. Calorimeter

Heat of solution (Cal/g) of unhydrated cement

where 0.2 is the specific heat of unhydrated cement.

For determining heat of solution of the hydrated cement, one of the glass vials is opened and the adherent wax is removed. The cement is ground rapidly, to avoid carbonation, to pass an 850 micron sieve. From this weigh out 4.2 g and 7.0 g of cement samples for heat of solution and loss on ignition.

The heat of solution of hydrated cement (Cal/g ignited weight)

$$= \frac{\text{Heat capacity} \times \text{corrected temperature rise}}{\text{Weight of sample corrected for ignition loss}} \times 0.4(M_0 - M)$$

The ignition loss can be obtained by placing the sample in a cool furnace and raising the temperature of the furnace to 900°C over a period of 1 hour. The sample is kept at 900° ± 50°C for 3-4 hours and then cooled in a desiccator containing anhydrous calcium chloride. Weigh after half an hour. The difference in the two weighings give the loss on ignition.

To determine the heat capacity sufficient quantity of zinc oxide is ignited for one hour at 900° ± 50°C. It is cooled in a desiccator containing anhydrous calcium chloride and ground to pass 250 micron sieve. About 7 g of this ignited oxide is reheated to 900° ± 50°C for 5 minutes and then cooled for about 2½ hours (not more than 5 hours). The calorimeter is assembled and temperature reading correct to 0.001°C is recorded to determine the initial heating or cooling correction. The zinc oxide is then introduced. The temperature readings are recorded at one minute intervals until the solution is complete. The recording of readings is continued for next 5 minutes to determine the final heating or cooling correction. The initial and final heating or cooling rates against the corresponding calorimeter temperature are plotted. The two points thus obtained are joined by a straight line. From this graph the corrections are read off for each temperature reading during the solution period. Heat capacity is calculated from the expression.

$$\text{Heat capacity (Cal/°C)} = \frac{\text{Weight of ZnO}}{\text{Corrected temperature rise}} - [256.1 - 0.1(30.0 - t_0) - 0.1(t_0)]$$

$$= \frac{\text{Weight of ZnO} (259.1 - 0.2(t_0 - 30.0))}{\text{Corrected temperature rise}}$$

where, 256.1 is the heat of solution of zinc oxide at 30°C and 0.2 the negative temperature coefficient of the heat of solution, is the final temperature of the calorimeter, 0.1 is the specific heat of zinc oxide and is the room temperature in °C.

Specific Gravity Test

The specific gravity of hydraulic cement is obtained using Le-Chatelier flask shown in Fig. 5.13.

SCE

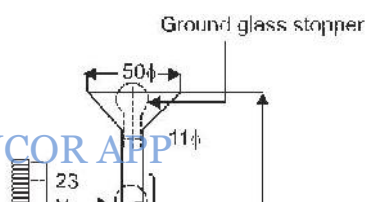

Dept of Civil

Fig. Le-Chatelier Flask for Specific Gravity Test

Conditions Affecting Specific Gravity: Long seasoning is the chief cause of a low specific gravity in unadulterated cement. This is because the freshly ground cement when exposed to air rapidly absorbs moisture and carbon dioxide. Cements with high contents of iron oxide have a higher specific gravity. The effect of fineness of grinding upon specific gravity is slight. Very finely ground cements are likely to have lower specific gravities.

Test Procedure: The flask is filled with either kerosene free of water, or naphtha having a specific gravity not less than 0.7313 to a point on the stem between zero and 1-ml mark. The flask is immersed in a constant temperature water bath and the reading is recorded. A weighed quantity of cement (about 64 g of Portland cement) is then introduced in small amounts at the same temperature as that of the liquid. After introducing all the cement, the stopper is placed in the flask and the flask rolled in an inclined position, or gently whirled in a horizontal circle, so as to free the cement from air until no further air bubbles rise to the surface of the liquid. The flask is again immersed in the water-bath and the final reading is recorded. The difference between the first and the final reading represents the volume of liquid displaced by the weight of the cement used in the test.

Chemical Tests (IS: 4032)

Loss on ignition: 1.00 g of the sample is heated for 15 minutes in a weighed and covered platinum crucible of 20 to 25 ml capacity by placing it in a muffle furnace at any temperature between 900° and 1000°C. It is then cooled and weighed. Thereafter, the loss in weight is checked by a second heating for 5 minutes and reweighing. The loss in the weight is recorded as the loss on ignition and the percentage of loss on ignition to the nearest 0.1 is calculated ($\text{loss in weight} \times 100$). The percentage loss on ignition should not exceed 4 per cent.

Silica: 0.5 g of the sample is kept in an evaporating dish, moistened with 10 ml of distilled water at room temperature to prevent lumping. To this 5 to 10 ml of hydrochloric acid is added, and digested with the aid of gentle heat and agitation until solution is complete. Dissolution may be aided by light pressure with the flattened end of a glass rod. The solution is evaporated to dryness on a steam bath. Without heating the residue any further, it is treated with 5 to 10 ml of hydrochloric acid and then with an equal amount of water. The dish is covered and digested for 10 minutes on a water bath. The solution with an equal volume of hot water is diluted and is immediately filtered through an ashless filter paper, and the separated silica (SiO_2) is washed thoroughly with hot water and the residue is reserved.

The filtrate is again evaporated to dryness, baking the residue in an oven for one hour at 105°C to 110°C. Then the residue is added with 10 to 15 ml of hydrochloric acid (1:1) and is heated on a water bath. This solution is then diluted with an equal volume of hot water and the small amount of silica it contains is filtered and washed on another filter paper. The filtrate and washings are reserved for the

determination of combined alumina and the ferric oxide.

The papers containing the residues are transferred to a weighed platinum crucible. The papers are dried and ignited, first at a low heat until the carbon of the filter papers is completely consumed without inflaming, and finally at 1100°C to 1200°C until the weight remains constant (say W).

The ignited residue thus obtained, which will contain small amounts of impurities is treated in the crucible with a few drops of distilled water, about 10 ml of hydrofluoric acid and one drop of sulphuric acid and evaporated cautiously to dryness. Finally, the small residue is heated at 1050°C to 1100°C for a minute or two: cooled and weighed (say W). The difference between this weight and the weight of the ignited residue represents the amount of silica (W).

2

Silica (%) = $200 (W -$

Combined Ferric Oxide and Alumina:

heated to a boil. A few drops of bromine water or concentrated nitric acid is added during boiling in order to oxidize any ferrous ion to the ferric condition. It is then treated with ammonium hydroxide (1:1), drop by drop, until the solution smells of ammonia. The solution containing the precipitates of aluminium and ferric hydroxides is boiled for one minute. The precipitate is allowed to settle, filtered through an ashless filter paper and washed with two per cent hot ammonium nitrate solution. The filtrate and washings are set aside.

The precipitate and the filter paper is transferred to the same beaker in which the first precipitation was effected. The precipitate is then dissolved in hydrochloric acid (1:3). The solution is diluted to about 100 ml and the hydroxides are reprecipitated. The solution is filtered and precipitated with two 10 ml portions of hot ammonium nitrate solution. The filtrate and washings are then combined with the filtrate set aside and is reserved for the determination of calcium oxide.

The precipitate is placed in a weighed platinum crucible, heated slowly until the papers are charred, and finally ignited to constant weight at 1050°C to 1100°C with care to prevent reduction, and weighed (W) as combined alumina and ferric oxide.

If silica is suspected to be carried into the filtrate used for this estimation, the residue in the crucible is treated with a drop of water, about 5 ml of hydrofluoric acid and a drop of sulphuric acid and is evaporated cautiously to dryness. Finally, the crucible is heated at 1050°C to 1100°C for one or two minutes; cooled and weighed (W). The difference between this weight and the weight (W), represents the amount of residue silica. This amount is subtracted from the weight of ferric oxide and alumina found as W and the same amount is added to the amount of silica (W). The ratio of percentages of alumina to iron oxide should not exceed 0.66.

Combined ferric oxide and alumina (%) = weight of residue × 200

Ferric Oxide:

vigorously, 50 ml of hydrochloric acid is added. If necessary, the solution is heated and cement is ground with flattened end of a glass rod until it is evident that cement is completely decomposed. The solution is heated to a boil and is treated with stannous chloride solution added drop by drop while stirring, until the solution is dicolorized. A few drops of stannous chloride solution is added in excess and the solution is cooled to room temperature. Then, 15 ml of a saturated solution of mercuric chloride and 25 ml of manganese sulphate solution are added and titrated with standard solution of potassium permanganate until the permanent pink colour is obtained. Iron as ferric oxide is calculated.

Alumina:

total weight of oxides (W). The remainder is the weight of alumina and of small amounts of other oxides reported as alumina.

Calcium Oxide:

acidified with hydrochloric acid and evaporated to a volume of about 100 ml. 40 ml of saturated bromine water is added to the hot solution and ammonium hydroxide is added until the solution is distinctly alkaline. The combined filtrate reserved in the combined ferric oxide and alumina test is added. The solution is boiled for 5 minutes or more, making certain that the solution is at all times distinctly alkaline. Then the precipitate is allowed to settle, filtered and washed with hot water.

The beaker and filter is washed once with nitric acid (1:33) and finally with hot water. Any precipitate (of manganese dioxide) that may be left on the tunnel is discarded. The filtrate is mixed with hydrochloric acid and boiled until all the bromine is expelled. 25 ml of boiling ammonium oxalate solution is added to the boiling solution. The solution is made alkaline with ammonium hydroxide and brought to boiling, the boiling being continued until the precipitated calcium oxalate assumes a well-defined, granular form. The precipitate is allowed to stand for about 20 minutes or until it has settled, filtered and washed moderately with ammonium oxalate solution (one gram per litre). The filtrate and washings (W) are set aside for estimating magnesia.

The precipitated lime after ignition and heating at 1100°C-1200°C is weighed.

The percentage of CaO = $\frac{\text{weight of residue} \times 200}{2.8 \text{ SiO}_2 + 1.2 \text{ Al}_2\text{O}_3 + 0.65 \text{ Fe}_2\text{O}_3}$. Also CaO 0.7SO₃

in per cent should not be less than 0.66.

Magnesia: The filtrate (W₃) is acidified with hydrochloric acid and is concentrated to about 150 ml. To this solution, about 10 ml of ammonium hydrogen phosphate solution (250 g per litre) is added and the solution is cooled by placing in a beaker of ice water. After cooling, ammonium hydroxide is added drop by drop, while stirring constantly, until the crystalline magnesium ammonium phosphate begins to form, and then the reagent is added in moderate excess (5 to 10 per cent of the volume of the solution), the stirring being continued for several minutes. The solution is set aside for at least 16 hours in a cool atmosphere and then filtered. The precipitate is washed with ammonium nitrate wash solution (100 g of ammonium nitrate dissolved in water, 200 ml of ammonium hydroxide added and diluted to one litre). It is then charred slowly and the resulting carbon is burnt carefully. The precipitate is ignited at 1100°C to 1200°C to constant weight, taking care to avoid bringing the pyrophosphate to melting.

From the weight of the magnesium pyrophosphate obtained, the magnesia content of the material taken for the test is calculated.

The percentage of MgO = weight of residue × 72.4.

Free magnesia in cement should be less than 4 per cent.

Sulphuric Anhydride: To one gram of the sample, 25 ml of cold water is added and while the mixture is stirred vigorously 5 ml of hydrochloric acid is added. If necessary, the solution is heated and the material is ground with the flattened end of a glass rod until it is evident that the decomposition of cement is complete. The solution is diluted to 50 ml and digested for 15 minutes. The residue is filtered and washed thoroughly with hot water. The filter paper with the residue (W₄) is set aside. The filtrate is diluted to 250 ml and heated to boiling. 10 ml of hot barium chloride (100 g per litre) solution is added drop by drop and the boiling is continued until the precipitate is well formed. The solution is digested on steam bath for 4 hours or preferably overnight. The precipitate is filtered and the precipitate is washed thoroughly. The filter paper and the contents are placed in a weighed platinum or porcelain crucible and slowly the paper is incinerated without inflaming. Then it is ignited at 800°C to 900°C, cooled in a desiccator and the barium sulphate is weighed. From the weight of the barium sulphate obtained, the sulphuric anhydride content of the material taken for the test is calculated. The percentage of SO₃ = weight of residue × 34.3. Sulphur in cement should be less than 2.5 per cent.

Insoluble Residue: The filter paper containing the residue (W₄) is digested in 30 ml of hot water and 30 ml of 2 N sodium carbonate solution maintaining constant volume, the solution being held for 10 minutes at a temperature just short of boiling. It is then filtered and washed with dilute hydrochloric acid (1:99) and finally with hot water till free from chlorides. The residue is ignited in a crucible at 900°C to 1000°C, cooled in a desiccator and weighed. The insoluble residues should not exceed 1.5 per cent.

2.7 Types Of Cement

Cements of unique characteristics for desired performance in a given environment are being manufactured by changing the chemical composition of OPC or by using additives, or by using different raw materials. Some of the cements available in the market are as follows.

The basis of application of rapid hardening cement (RHC) is hardening properties and heat emission rather than setting rate. This permits addition of a little more gypsum during manufacture to control the rate of setting. RHC attains same strength in one day which an ordinary cement may attain in 3 days. Increasing the sulphate content largely is normally obtained from OPC by finely grinding (450 mesh) of rapid hardening cement is about 10 per cent more than the ordinary cement. Concrete made with RHC can be safely exposed to frost, since it matures more quickly. has high lime content and can be obtained by

Properties:	Initial setting time	30 minutes (minimum)
	Final setting time	10 hours (maximum)
	Compressive strength	
	1 day	16.0 N/mm ²
	3 day	27.5 N/mm ²

Uses: It is suitable for repair of roads and bridges and when load is applied in a short period of time.

High Alumina Cement (IS: 6452): This is not a type of Portland cement and is manufactured by fusing 40 per cent bauxite, 40 per cent lime, 15 per iron oxide with a little of ferric oxide and silica, magnesia, etc. (Table 5.5) at a very high temperature. The alumina content should not be less than 32%. The resultant product is ground finely. The main cement ingredient is monocalcium aluminate CA which interacts with water and forms dicalcium octahydrate hydroaluminat and aluminium oxide hydrate.

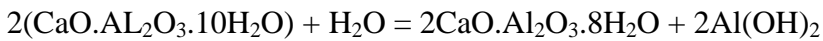

The dicalcium hydroaluminat gel consolidates and the hydration products crystallise. The rate of consolidation and crystallisation is high leading to a rapid gain of strength. Since C₃A is not present, the cement has good sulphate resistance.

Table 8 Composition of a Typical High Alumina Cement

Composition	Percentage
Al ₂ O ₃ , TiO ₂	43.5
Fe ₂ O ₃ , FeO, Fe ₃ O ₄	13.1
CaO	37.5
SiO ₂	3.8
MgO	0.3
SO ₃	0.4
Insoluble material	1.2
Loss on ignition	0.2

Properties: It is not quick setting: initial setting time (minimum) is 30 minutes, even up to 2 hours. The final setting time should not exceed 600 minutes. It attains strength in 24 hours, high early strength, high heat of hydration and resistance to chemical attack. Compressive strength after one day is 30.0 N/mm² and after 3 days it is 35.0 N/mm². After setting and hardening, there is no free hydrated lime as in the case of ordinary Portland cement. The fineness of the cement should not be less than 225 m²/kg. The cement should not have expansion more than 5 mm.

Uses: It is resistant to the action of fire, sea water, acidic water and sulphates and is used as refractory concrete, in industries and is used widely for precasting. It should not be used in places where temperature exceeds 18°C.

Supersulphated Portland Cement (IS: 6909) is manufactured by intergrinding or intimately blending a mixture of granulated blast furnace slag not less than 70 per cent, calcium sulphate and small quantity of 33 grade Portland cement. In this cement tricalcium aluminate which is susceptible to sulphates is limited to less than 3.5 per cent. Sulphate resisting cement may also be produced by the addition of extra iron oxide before firing; this combines with alumina which would otherwise form C₃A, instead forming C₄AF which is not affected by sulphates. It is used only in places with temperature below 40°C.

Water resistance of concretes from supersulphate Portland cements is higher than that of common Portland cements because of the absence of free calcium oxide hydrate. In supersulphate Portland

cements the latter is bound by slag into calcium hydroaluminates of low solubility and calcium hydrosilicates of low basicity, whereas concretes from Portland cement carry a large amount of free calcium oxide hydrate which may wash out and thus weaken them. Supersulphate Portland cement has satisfactory frost and air resistances, but it is less resistant than concrete from Portland cement due to the fact that hydrosilicates of low basicity show greater tendency to deformation from humidity fluctuations and resist the combined action of water and frost less effectively.

Properties:

sulphates. Compressive strength should be as follows:

72 ± 1 hour	15 N/mm ²
168 ± 2 hours	22 N/mm ²
672 ± 4 hours	30 N/mm ²

It has low heat of hydration and is resistant to chemical attacks and in particular to

It should have a fineness of 400 m²/kg. The expansion of cement is limited to 5 mm. The initial setting time of the cement should not be less than 30 minutes, and the final setting time should not be more than 600 minutes.

Uses: Supersulphated Portland cement is used for similar purpose as common Portland cement. But owing to its higher water-resisting property, it should be preferred in hydraulic engineering installations and also in constructions intended for service in moist media. RCC pipes in ground water, concrete structures in sulphate bearing soils, sewers carrying industrial effluents, concrete exposed to concentrated sulphates of weak mineral acids are some of the examples of this cement. This cement should not be used in constructions exposed to frequent freezing-and-thawing or moistening-and-drying conditions.

Sulphate Resisting Portland Cement (IS: 12330): In this cement the amount of tricalcium aluminate is restricted to an acceptably low value (< 5). It should not be mistaken for super-sulphated cement. It is manufactured by grinding and intimately mixing together calcareous and argillaceous and/ or other silica, alumina and iron oxide bearing materials. The Materials are burnt to clinkering temperature. The resultant clinker is ground to produce the cement. No material is added after burning except gypsum and not more than one per cent of air-entraining agents are added.

Properties: The specific surface of the cement should not be less than 225 m²/kg. The expansion of cement is limited to 10 mm and 0.8 per cent, when tested by Le-chatelier method and autoclave test, respectively. The setting times are same as that for ordinary Portland cement. The compressive strength of the cubes should be as follows.

72 ± 1 hour	10 N/mm ²
168 ± 2 hours	16 N/mm ²
672 ± 4 hours	33 N/mm ²

It should have a fineness of 400 m²/kg. The expansion of cement is limited to 5 mm. The initial setting line of the cement should not be less than 30 mm and the final setting time should not be more than 600 mm.

This cement can be used as an alternative to ordinary Portland cement or Portland pozzolana cement or Portland slag cement under normal conditions. Its use however is restricted where the prevailing temperature is below 40°C. Use of sulphate resisting cement is particularly beneficial in conditions where the concrete is exposed to the risk of deterioration due to sulphate attack; concrete in contact with soils or ground waters containing excessive sulphate as well as concrete in sea water or exposed directly to sea coast.

Portland slag Cement (IS: 455): It is manufactured either by intimately intergrinding a mixture of Portland cement clinker and granulated slag with addition of gypsum or calcium sulphate, or by an intimate and uniform blending of Portland cement and finely ground granulated slag. Slag is a non-metallic product consisting essentially of glass containing silicates and alumino-silicates of lime and other bases, as in the case of blast-furnace slag, which is developed simultaneously with iron in blast furnace or electric pig iron furnace. Granulated slag is obtained by further processing the molten slag by

rapid chilling or quenching it with water or steam and air. The slag constituent in the cement varies between 25 to 65 per cent. The initial and final setting times and compressive strength requirements are same as that for 33 grade ordinary Portland cement.

Properties: The specific surface of slag cement should not be less than 225 m²/kg. The expansion of the hydration of the slag cement should not be more than 10 mm and 0.8 per cent when tested by Le Chatelier method and autoclave test, respectively. The initial and final setting times and compressive strength requirements are same as that for 33 grade ordinary Portland cement.

Low Heat Portland Cement (IS:12600)

This cement can be used in all places where OPC is used. However, because of its low heat of hydration (LHC), the tricalcium aluminate component in cement is minimised and a high percentage of dicalcium silicate and tetracalcium aluminoferrite is added. The heat of hydration should not be more than 272 and 314 J/g at the end of 7 and 28 days respectively. To limit the heat of hydration of low heat Portland cement the ultimate strength is same as that of OPC. To meet this requirement, specific surface of cement is

Properties: Less heat is evolved during setting low heat Portland cement. When tested by Le Chatelier method and autoclave test the expansion should not be more than 10 mm and 0.8%, respectively. The minimum initial setting time should not be less than 60 minutes, and the final setting should not be more than 600 minutes.

The compressive strength should be as follows.

72 ± 1 hour	10 N/mm ²
168 ± 2 hours	16 N/mm ²
672 ± 4 hours	35 N/mm ²

Uses: It is most suitable for large mass concrete works such as dams, large raft foundations, etc.

Portland Pozzolana Cement (IS: 1489 (Part I): It is manufactured by grinding Portland cement clinker and pozzolana (usually fly ash 10-25% by mass of PPC) or by intimately and uniformly blending Portland cement and fine pozzolana. Pozzolana (burnt clay, shale, or fly ash) has no cementing value itself but has the property of combining with lime to produce a stable lime-pozzolana compound which has definite cementitious properties. Free lime present in the cement is thus removed. Consequently, the resistance to chemical attack increases making it suitable for marine works. The hardening of Portland pozzolana cement consists in hydration of Portland cement clinker compounds and then in interaction of the pozzolana with calcium hydroxide released during the hardening of clinker. At the same time, calcium hydroxide is bound into a water-soluble calcium hydrosilicate according to the reaction with the effect that pozzolana Portland cement acquires greater water-resisting property than ordinary Portland cement.



Properties: These have lower rate of development of strength but ultimate strength is comparable with ordinary Portland cement.

Compressive Strength	72 ± 1 hr	16.0 N/mm ²
	168 ± 2 hrs	22.0 N/mm ²
	672 ± 4 hrs	33.0 N/mm ²

The initial and the final setting times are 30 minutes (minimum) and 600 minutes (maximum), respectively. The drying shrinkage should not be more than 0.15% and the fineness should not be less than 300 m²/kg.

Uses: It has low heat evolution and is used in the places of mass concrete such as dams and in places of high temperature.

Quick Setting Portland Cement: The quantity of gypsum is reduced and small percentage of aluminium sulphate is added. It is ground much finer than ordinary Portland cement.

Properties: Initial setting time = 5 minutes

Use: It is used when concrete is to be laid under water or in running water.

Masonry Cement (IS 3466): The Portland cement clinker is ground and mixed intimately with pozzolanic material (flyash or calcined clay), or non-pozzolanic (inert) materials (lime-stone, conglomerates, dolomite, granulated slag) and waste materials (carbonated sludge, mine tailings) and gypsum and air entraining plasticizer in suitable proportions. The physical requirements of masonry cement are as follows.

1. Fineness: Residue on 45-micron IS Sieve, Max, Percent (by wet sieving)	15
2. Setting Time (by Vicat Apparatus):	
(a) Initial, Min	90 min
(b) Final, Max	24 h
3. Soundness:	
(a) Le-Chatelier expansion, Max	10 mm
(b) Autoclave expansion, Max	1 %
4. Compressive Strength: Average strength of not less than 3 mortar cubes of 50 mm size, composed of 1 part masonry cement and 3 parts standard sand by volume, Min	
7 days	2.5 MPa
28 days	5 MPa
5. Air Content: Air content of mortar composed of 1 part masonry cement and 3 parts standard sand by volume, Min	6 per cent
6. Water Retention: Flow after suction of mortar composed of 1 part masonry cement and 3 parts standard sand by volume, Min	60 % of original flow

White and Coloured Portland Cement (IS: 8042): It is manufactured from pure white chalk and clay free from iron oxide. Greyish colour of cement is due to iron oxide. So, the iron oxide is reduced and limited below 1 per cent. Coloured cements are made by adding 5 to 10 per cent colouring pigments before grinding. These cements have same properties as that of ordinary Portland cement and are non-staining because of low amount of soluble alkalis. Sodium aluminofluoride is added during burning which acts as a catalyst in place of iron.

Properties: Loss on ignition of white cement is nil. The compressive and transverse strength of this cement is 90 per cent of that of 33 grade ordinary Portland cement.

Uses: These cements are used for making terrazzo flooring, face plaster of walls (stucco), ornamental works, and casting stones.

Air Entraining Cement: Vinsol resin or vegetable fats and oils and fatty acids are ground with ordinary cement. These materials have the property to entrain air in the form of fine tiny air bubbles in concrete.

Properties: Minute voids are formed while setting of cement which increases resistance against freezing and scaling action of salts. Air entrainment improves workability and water/cement ratio can be reduced which in turn reduces shrinkage, etc.

Uses: Air entraining cements are used for the same purposes as that of OPC.

Calcium Chloride Cement: It is also known as extra rapid hardening cement and is made by adding 2 per cent of calcium chloride. Since it is deliquescent, it is stored under dry conditions and should be consumed within a month of its dispatch from the factory.

Natural Aggregates: These are obtained by crushing from quarries of igneous, sedimentary or metamorphic rocks. Gravels and sand reduced to their present size by the natural agencies also fall in this category. The most widely used aggregate are from igneous origin. Aggregates obtained from pits or dredged from river, creek or sea are most often not clean enough or well graded to suit the quality requirement. They therefore require sieving and washing before they can be used in concrete.

is known as bulking. The water forms a film over the fine aggregate particles, exerts force of surface tension and pushes them apart increasing the volume. The extent of bulking depends upon the percentage of moisture present in the sand and its fineness. With ordinary sand bulking varies from 15- 30 percent. It increases with moisture content up to a certain point (4-6%), reaches maximum, the film of water on the sand surface breaks, and then it starts decreasing. Figure 6.2 shows the bulking of sand with moisture content. In preparing concrete mixes if sand is measured by volume and no allowance is made for bulking, the moist sand will occupy considerably larger volume than that prepared by the dry sand and consequently the mix will be richer. This will cause, less quantity of concrete per bag of cement. For example, if the bulking of sand is 10% and if mix ratio is 1:2:4, the actual volume of sand used will be $1.1 \times 2 = 2.2$ instead of 2 per unit volume of cement. If this correction is not applied the actual dry sand in the concrete will be , instead of 2 per unit volume of cement. The mix proportion then would be 1:1.82:4 rather than 1: 2: 4. Which indicates lesser production of concrete. Also, there will be chances of segregation, honeycombing and reduced yield of concrete.

Bulking of sand can be determined, in field, by filling a container of known volume (A) with damp sand in the manner in which the mixer hopper will be filled. The height of sand in the container is measured. The sand is then taken out of container carefully, ensuring no sand is lost during this transaction. The sand is then either dried and filled back into the gauge box, or the container is filled with water and the damp sand is poured in to displace the water. Whichever method is adopted, the new depth of aggregate in the container gives the unbulked volume (B).
 Then percentage bulking expressed as a percentage of the dry volume = $\frac{A - B}{B} \times 100$ - **Note:**

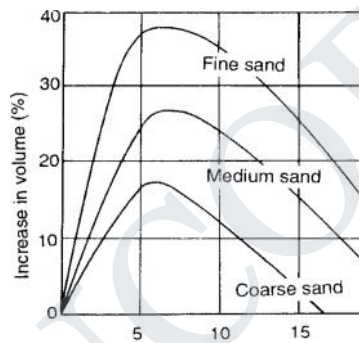

The dry and fully

Fig. 34 Effect of Moisture Content on Bulking of Sand

2.8 Testing Of Aggregates

The size, shape, grading of aggregate and their surface moisture affect directly the workability and strength of concrete whereas soundness, alkali-aggregate reaction and presence of deleterious substances adversely affect the soundness and durability of concrete. The following tests are conducted to ensure satisfactory performance of aggregate

Flakiness Index and Elongation Index Test (IS: 2386 (Part II))

Because of large number of flaky particles in the coarse aggregate more voids are formed in the concrete, consequently more mortar is required to fill the voids, resulting in uneconomy. Also, durability of concrete will be affected.

For flakiness index (F.I) and elongation index (E.I) sufficient quantity of aggregate is taken so as to provide at least 2000 pieces of any fraction to be tested. The sample is sieved through IS sieves as given in Table 6.3.

Table 6.3 Dimensions of Thickness and Length Gauges

Size of aggregate		Thickness gauge (mm)	Length gauge (mm)
Passing through IS sieve	Retained on IS sieve		
63 mm	50 mm	33.20	
50 mm	40 mm	27.00	81.0
40 mm	25 mm	19.50	64.5
31.5 mm	25 mm	16.95	
25 mm	20 mm	13.50	40.5
20 mm	15 mm	10.80	32.4
15 mm	12.5 mm	8.55	25.6
12.5 mm	10 mm	6.75	20.2
10 mm	6.3 mm	4.89	14.7

For determining *F.I*, the aggregate retained on sieves are separated. Now, each aggregate piece is passed through the corresponding slot in the thickness gauge (Fig. 6.4). Flakiness index is given by,

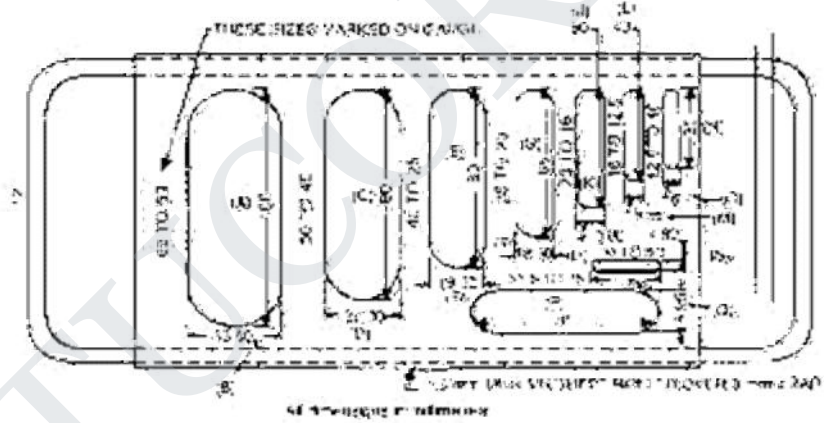

Fig. 6.4. Thickness Gauge

$$F.I = \frac{\text{Weight of aggregate passing through the slot of the thickness gauge}}{\text{Total weight of sample}} \times 100$$

For determining *E.I* the aggregate are sieved through the corresponding sieves. Aggregate retained on each sieve are separated. Then each aggregate piece is passed through the corresponding slot of length gauge (Fig. 6.5)

$$E.I = \frac{\text{Weight of the aggregate retained on length gauge}}{\text{Total weight of aggregate}} \times 100$$

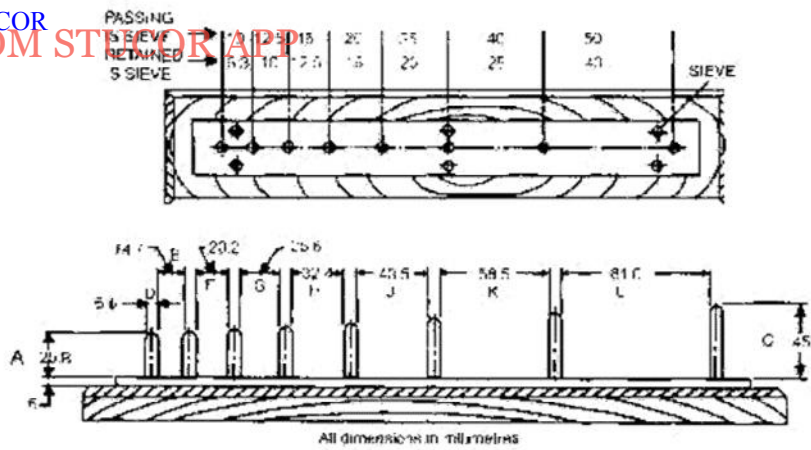

Fig. 6.5 Length Gauge

Specific Gravity and Water Absorption Test (IS: 2386 (Part III))

Aggregate Larger than 10 mm: A sample of 2000 g of aggregate is used for conducting the test. Aggregate which have been artificially heated should not normally be used.

The sample is thoroughly washed to remove finer particles and dust, drained and then placed in the wire basket and immersed in distilled water at a temperature between 22-32°C with a cover of at least 50 mm of water above the top of the basket.

Immediately after immersion the interrupted air is removed from the sample by lifting the basket containing it 25 mm above the base of the tank and allowing it to drop 25 times at the rate of about one drop per second. The basket and aggregate are kept completely immersed during the operation and for a period of 24 ± 1/2 hours afterwards. The basket and the sample are jolted and weighed in water (weight A₁). These are then removed from the water and allowed to drain for a few minutes, after which the aggregate are gently emptied from the basket on to one of the dry clothes, and the empty basket is returned to the water, jolted 25 times and weighed in water (weight A₂).

The aggregate placed on the dry cloth are gently surface dried with the cloth, and are completely surface dried. The aggregate are then weighed (weight B).

The aggregate are thereafter placed in an oven at a temperature of 100-110°C and maintained at this temperature for 24 ± 1/2 hours. It is then removed from the oven, cooled in the air-tight container and weighed (weight C). The computations are as under

$$\text{Specific gravity} = \frac{C}{B - A}$$

$$\text{Apparent specific gravity} = \frac{C}{C - A}$$

$$\text{Water absorption (per cent of dry weight)} = \frac{(B - A)}{C} \times 100$$

- where A the weight in g of the saturated aggregate in water (A₁ - A₂)
 B = the weight in g of the saturated surface dry aggregate in air
 C the weight in g of oven-dried aggregate in air

Aggregate Between 40 mm and 10 mm: A sample of about 1000 g of the aggregate is screened on a 10 mm sieve, thoroughly washed to remove fine particles of dust, and immersed

Table Weights of Sample

Max. size present in substantial Proportion (mm)	Approximate sample weight (g)
63 to 25	6000
20 to 12.5	1000
10 to 6.3	500
4.75 or smaller	300

For testing fine aggregate for clay, fine silt and dust weight approximately 300g of the air dried sample, passing the 4.75 mm IS sieve, and place it in the screw-topped glass jar, together with 300 ml of diluted sodium oxalate solution. The jar is then rotated about its long axis (with this axis horizontal) at a speed of 80 rpm for 15 minutes. The suspension is then poured into 1000 ml measuring cylinder and the residue washed by gentle swirling and decantation of successive 150 ml portions of sodium oxalate solution, the washings being added to the cylinder until the volume is made up to 1000 ml.

For coarse aggregate the sample is placed in a suitable container, covered with a measured volume of sodium oxalate solution (0.8 g/l), agitated vigorously and the liquid suspension transferred to the 1000 ml measuring cylinder. The process is repeated until all clayey material is transferred to the cylinder. The volume is made upto 1000 ml with sodium oxalate solution.

The percentage of fine clay, silt and dust, A, is determined by the following formula

$$A = \frac{100 \times 1000 \times W_2}{W_1 \times V} - 0.8$$

Where

W₁ = weight of original sample (g)

W₂ = weight of dried sample (g)

V = volume of the pycnometer (ml)

0.8 = weight of sodium oxalate (g) in one litre of the dilute solution.

Note: These impurities should not exceed 3% for fine and coarse aggregates except for crushed fine aggregate for which the limit is 15% (IS:383).

Aggregate Smaller than 10 mm: A Pycnometer shown in Fig. 37 is used for determining specific gravity. A sample about 1000 g for 10 mm to 4.75 mm or 500 g if finer than 4.75 mm, is placed in the tray and covered with distilled water at a temperature of 22-32°C. Soon after immersion, air entrapped in or bubbles on the surface of the aggregate are removed by gentle agitation with a rod. The sample is kept immersed for 24 ± 1/2 hours.

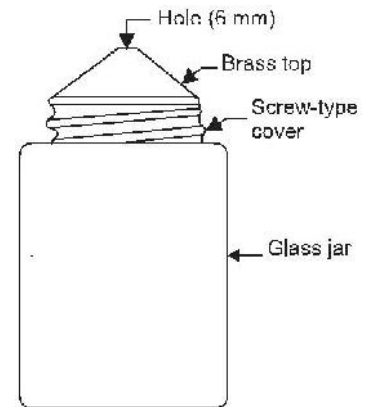

Fig.37 Pycnometer

The water is then carefully drained from the sample through a filter paper, any material retained being returned to the sample. The aggregate including any solid matter retained on the filter paper should be exposed to a gentle current of warm air to evaporate surface moisture and stirred at frequent intervals to insure uniform drying until no free surface moisture can be seen and the material just attains a free-running condition. The saturated and surface-dry sample is weighted (weight A).

The aggregate is then placed in the pycnometer which is filled with distilled water. The pycnometer is dried on the outside and weighed (weight B).

The contents of the pycnometer are emptied into the tray. The pycnometer is refilled with distilled water to same level as before, dried on the outside and weighed (weight C).

The water is then carefully drained from the sample by decantation through a filter paper and any material retained is returned to the sample. The sample is placed in the oven at a temperature of 100 to 110°C for 24 ± 1/2 hours, during which period it should be stirred occasionally to facilitate drying. It is

then cooled in the air-tight container and weighed (weight D).

D

$$\text{Specific gravity} = \frac{A - (B - C)}{D}$$

$$\text{Apparent specific gravity} = \frac{D - (B - C)}{D}$$

$$\text{Water absorption (per cent of dry weight)} = \frac{A - D}{D} \times 100$$

Where

A = weight in g of saturated surface-dry sample

B = weight in g of pycnometer or gas jar containing sample and filled with distilled water

C = weight in g of pycnometer or gas jar filled with distilled water only

D = weight in g of oven-dried sample

Bulking Test for Fine Aggregate (IS: 2386 (Part III))

Fine aggregate (sand) has a tendency to increase in volume (bulk) depending upon the moisture present in it. In making concrete mix, if the batching is done by volume, the actual quantity of sand in each batch will be less than the recommended volume and consequently the mix will be rich in cement, i.e. the proportions of cement and sand will be different to be provided. This will result in uneconomy and may affect adversely the concrete also. Therefore, the amount of sand will have to be increased by percentage bulking (B).

The field method of determination of bulking is explained in Sec. 6.3. In the laboratory test sufficient quantity of oven dried sand is filled in graduated cylinder up to a certain fixed mark. The sand is emptied in a container and the weight of dry sand is determined. 1% water is added in the sand mixed thoroughly and filled in the graduated cylinder. The volume of sand will be found to increase. The process is repeated by increasing the percentage of water in steps of 1% each time till a decrease in the volume of sand is observed. Still this addition of water is continued till the volume of sand comes back to the original volume (fully saturated).

A graph is plotted between moisture content and percentage increase in volume. The graph will be of the shape as shown in Fig. 6.2. The percentage bulking is given by,

$$B = \frac{\text{bulked volume} - \text{dry volume}}{\text{dry volume}} \times 100$$

Crushing Value Test (IS: 2386 (Part IV))

The material for the test should consist of aggregate passing 12.5 mm sieve and retained on 10 mm sieve. For other sizes, the materials are separated on the appropriate sieves given in Table 6.6.

Table 10 Details of Aggregate Crushing Test for Non-standard Sizes of Aggregate

Nominal sizes		Diameter of cylinder to be used (cm)	Size of sieve for separating fines
Passing through (mm)	Retained on (mm)		
25.00	20.00	15.0	4.75 mm
20.00	12.50	15.0	3.35 mm
10.00	6.30	15.0 or 7.5	1.70 mm
6.3	4.75	15.0 or 7.5	1.18 mm
4.75	3.35	15.0 or 7.5	850 micron
3.35	2.36	15.0 or 7.5	600 micron

Note: About 6500 g of natural aggregate is required to provide samples for the 150 mm cylinder, or about 1000 g for the 75 mm cylinder.

The aggregate is tested in a surface-dry condition. The weight of material comprising the test sample is determined (weight A).

The cylinder of the test apparatus is positioned on the base-plate and the test sample is added in thirds, each being subjected to 25 strokes from the tamping rod. The surface of the aggregate is carefully levelled and the plunger is inserted so that it rests horizontally on this surface.

The apparatus, with the test sample and plunger in position is then placed between the platens of the testing machine and loaded at an uniform rate as possible, so that the total load is reached in 10 minutes. The total load should be 400 kN.

The load is released and the whole of the material is removed from the cylinder and sieved on a 2.36 mm sieve for the standard test, or on the appropriate sieve given in Table 6.5. The fraction passing the sieve is weighed.

The ratio of the weight of fines formed to the total sample weight in each test is expressed as a percentage, recorded to the first decimal place:

$$\text{Aggregate crushing value} = \frac{B}{A} \times 100$$

Where

B = weight of fraction passing the appropriate sieve

A = weight of surface-dry sample

Aggregate Impact Value Test (IS:2386 (Part IV))

The aggregate impact value gives a relative measure of the resistance of an aggregate to sudden shock or impact, which in some aggregate differs from its resistance to a slow compressive load.

The test sample consists of aggregate the whole of which passes a 12.5 mm sieve and is retained on a 10 mm sieve. The aggregate comprising the test sample is dried in an oven for a period of four hours at a temperature of 100-110°C and cooled.

The measure is filled about one-third full with the aggregate and tamped with 25 strokes of the rounded end of the tamping rod. A further similar quantity of aggregate is added and a further tamping of 25 strokes is given. The measure is finally filled to overflowing, tamped 25 times and the surplus aggregate is struck off, using the tamping rod as a straight-edge. The net weight of aggregate in the measure is determined to the nearest gram (weight A).

A cup, 102 mm internal diameter and 50 mm deep, is fixed firmly in position on the base of the machine and the whole of the sample is placed in it and compacted by a single tamping of 25 strokes of the tamping rod.

The hammer is raised until its lower face is 380 mm above the upper surface of the aggregate in the cup, and allowed to fall freely on to the aggregate. The test sample is subjected to a total of 15 such blows each being delivered at an interval of not less than one second.

The crushed aggregate is then removed from the cup and the whole of it is sieved on 2.36 mm IS sieve until no further significant amount passes in one minute. The fraction passing the sieve is weighed to an accuracy of 0.1 g (weight B). The fraction retained on the sieve is also weighed (weight C) and, if the total weight (B + C) is less than the initial weight (A) by more than one gram, the result is discarded and a fresh test made. Two tests are made.

The ratio of the weight of fines formed to the total sample weight in each test are expressed as a percentage, recorded to the first decimal place:

$$\text{Aggregate impact value} = \frac{B}{A} \times 100$$

Where B = weight of fraction passing 2.36 mm sieve

A = weight of oven-dried sample

Aggregate Abrasion Value Test (IS: 2386 (Part IV))

The abrasion value of coarse aggregate may be determined by either Deval Machine or by Los Angeles machine.

Using Deval Machine

Abrasive Charge: The abrasive charge consists of 6 cast iron or steel spheres approximately 48 mm in diameter, each weighing between 390 and 445 g. An abrasive charge of 6 spheres weighing $2500 \pm$

The test sample consists of dry coarse aggregate made up of percentages of the various sizes conforming to one of the gradings shown in Table 6.7. The grading used should be that most nearly representing the coarse aggregate furnished for the work.

Table 11 Grading of Aggregate for Abrasion Test

Grading	Passing sieve	Retaining sieve	Percentage of sample
A	20 mm	12.5 mm	25
	25 mm	20 mm	25
	40 mm	25 mm	25
	50 mm	40 mm	25
B	20 mm	12.5 mm	25
	25 mm	20 mm	25
	40 mm	25 mm	50
C	20 mm	12.5 mm	50
	25 mm	20 mm	50
D	12.5 mm	4.75 mm	50
	20 mm	12.5 mm	50
E	10 mm	4.75 mm	50
	12.5 mm	10 mm	50

The weight of the test sample depends upon its average specific gravity as given below.

Range of specific Gravity	Weight of Sample (g)
Over 2.80	5500
2.4 to 2.80	5000
2.2 to 2.39	4500
< 2.20	4000

Procedure: The test sample and the abrasive charge are placed in the Deval abrasion testing machine and the machine is rotated for 10000 revolutions at a speed of 30 to 33 rev/min. At the completion of the test, the material is removed from machine and sieved on a 1.70 mm sieve. The material retained on the sieve is washed, dried and accurately weighed to the nearest gram.

The loss by abrasion is considered as the difference between the original weight of the sample and the weight of the material retained on the 1.70 mm sieve, expressed as percentage of the original weight of the test sample.

In case of crushed gravel, the percentage by weight of crushed fragments is determined, and the permissible percentage or wear is calculated as:

$$W = \frac{AL (100 - A)L'}{100}$$

Where ● W = permissible percentage of wear
A = percentage of uncrushed fragments

L = maximum percentage of wear permitted by the specifications for gravel consisting entirely of uncrushed fragments

100 – A = percentage of crushed fragments

L' = maximum percentage of wear permitted by the specifications for gravel consisting entirely of crushed fragments

Abrasive Charge: The abrasive charge consists of cast iron spheres or steel spheres approximately 48 mm in diameter and each weighing between 390 and 445 g.

The abrasive charge, depending upon the grading of the test sample should be as given in Table 12.

Table 12 Abrasive Charge for Los Angeles Test

Grading	Number of sphere	Weight of charge (g)
A	12	5000 ± 25
B	11	4584 ± 25
C	8	3330 ± 20
D	6	2500 ± 15
E	12	5000 ± 25
F	12	5000 ± 25
G	12	5000 ± 25

The test sample consists of clean aggregate dried in an oven at 105 -110°C to substantially constant weight.

Note: It is recognized that different specification limits may be required for gradings E, F and G than for A, B, C and D. It is urged that investigations be conducted to determine the relationship, if any, which exists between results for these coarse gradings using the 10000 g samples and the finer ones using the 5000 g samples.

The test sample and the abrasive charge is placed in the Los Angeles abrasion testing machine and the machine is rotated at a speed of 20 to 33 rev/min. For gradings A, B, C and D, the machine is rotated for 500 revolutions; for gradings E, F and G, it is rotated for 1000 revolutions. The machine is so driven and so counter-balanced as to maintain a substantially uniform peripheral speed. If an angle is used as the shelf, the machine is rotated in such a direction that the charge is caught on the outside surface of the angle. At the completion of the test, the material is discharged from the machine and a preliminary separation of the sample made on a sieve coarser than the 1.70 mm. The finer portion is then sieved on a 1.70 mm sieve. The material coarser than the 1.70 mm sieve is washed, dried in an oven at 105 -110°C to a substantially constant weight, and accurately weighed to the nearest gram. The difference between the original and the final weights of the test sample expressed as a percentage of the original weight of the test sample gives the percentage of wear.

Soundness Test (IS: 2386 Part V)

The sample of fine aggregate for the test is passed through 10-mm IS sieve and should be of such size that it yields not less than 100 g of each of the sizes as below.

Passing IS sieve	Retained on IS sieve
600 micron	300 micron
1.18 mm	600 micron
2.36 mm	1.18 mm
4.75 mm	2.36 mm
10 mm	4.75 mm

From the sample of coarse aggregate, sizes finer than 4.75 mm are removed and the size of sample for different sizes should be as follows.

Size (mm) (square hole sieve)	Yield (g)
10 to 4.75	300
20 to 10	1000
12.5 to 10 (33%)	
20 to 12.5 (67 %)	
40 to 20	
25 to 20 (33%)	1500
40 to 25 (67%)	
63 to 40	
50 to 40 (50%)	3000
63 to 50 (50%)	
80 or more	3000

Note: All-in-aggregate should be separated in two major fractions, finer than 4.75 mm and coarser than 4.75 mm, and tested.

In case of fine aggregate, these are thoroughly washed on a 300 micron IS sieve and dried to constant weight at 105 to 110°C and separated into different sizes by the set of sieves listed earlier to yield at least 100g each. The coarse aggregate sample are washed thoroughly and dried to constant weight at 105 to 110°C and separated into different sizes. Particles coarser than the 20 mm IS sieve are counted.

The aggregate sample is immersed for 16 to 18 hours in the prepared solution of either sodium sulphate or magnesium sulphate solution. The sample is maintained at $27 \pm 1^\circ\text{C}$. The aggregate sample is then removed from the solution and drained for 15 ± 5 minutes, placed in drying oven at 105-110°C and dried to constant weight. The sample is allowed to cool to room temperature. The process of immersion and drying is repeated for as many number of cycles as agreed to between the purchaser and vendor. The sample is then examined for quantitative and qualitative examination.

Quantitative examination: After the completion of final cycle the cooled sample is washed free from the sodium sulphate or magnesium sulphate with barium chloride. Each sample is dried to constant weight at 105 - 110°C and weighed. Fine aggregate are sieved over the same sieve on which it was retained before the test, and coarse aggregate over the following sieves.

Size of aggregate (mm)	Sieve used to determine loss (mm)
10 to 4.75	4
20 to 10	8
40 to 20	16
63 to 40	31.5

Qualitative examination: Fractions of samples coarser than 20 mm are examined qualitatively for each immersion as well as at the completion of the test. The effects observed may be classed as disintegration, splitting, crumbling, cracking, flaking, etc.

Chapter 3

Concrete

Concrete – Ingredients – Manufacturing Process – Batching plants – RMC – Properties of fresh concrete – Slump – Flow and compaction Factor – Properties of hardened concrete – Compressive, Tensile and shear strength – Modulus of rupture – Tests – Mix specification – Mix proportioning – BIS method – High Strength Concrete and HPC – Self compacting Concrete – Other types of Concrete – Durability of Concrete.

3.1 Concrete

Concrete is a mixture of cement (11%), fine aggregates (26%), coarse aggregates (41%) and water (16%) and air (6%).

Cement Powder

Cement + Water Cement Paste

Cement Paste + Fine Aggregate (FA) Mortar

Mortar + Coarse Aggregate (CA) Concrete

Portland cement, water, sand, and coarse aggregate are proportioned and mixed to produce concrete suited to the particular job for which it is intended.

Concrete a composite man-made material, is the most widely used building material in the construction industry. It consists of a rationally chosen mixture of binding material such as lime or cement, well graded fine and coarse aggregates, water and admixtures (to produce concrete with special properties). In a concrete mix, cement and water form a paste or matrix which in addition to filling the voids of the fine aggregate, coats the surface of fine and coarse aggregates and binds them together. The matrix is usually 22-34% of the total volume. Freshly mixed concrete before set is known as wet or green concrete whereas after setting and hardening it is known as set or hardened concrete.

3.2 Ingredients

The concrete consisting of cement, sand and coarse aggregates mixed in a suitable proportions in addition to water is called cement concrete. In this type of concrete cement is used as a binding material, sand as fine aggregates and gravel, crushed stones as coarse aggregates.

3.3 Manufacturing Process

A good quality concrete is essentially a homogeneous mixture of cement, coarse and fine aggregates and water which consolidates into a hard mass due to chemical action between the cement and water. Each of the four constituents has a specific function. The coarser aggregate acts as a filler. The fine aggregate fills up the voids between the paste and the coarse aggregate. The cement in conjunction with water acts as a binder. The mobility of the mixture is aided by the cement paste, fines and nowadays, increasingly by the use of admixtures.

Most of the properties of the hardened concrete depend on the care exercised at every stage of the manufacture of concrete. A rational proportioning of the ingredients of concrete is the essence of the mix design. However, it may not guarantee of having

achieved the objective of the quality concrete work. The aim of quality control is to ensure the production of concrete of uniform strength from batch to batch. This requires some rules to be followed in the various stages of concrete production and are discussed as follows. The stages of concrete production are:

1. Batching or measurement of materials
2. Mixing
3. Transporting
4. Placing
5. Compacting
6. Curing
7. Finishing

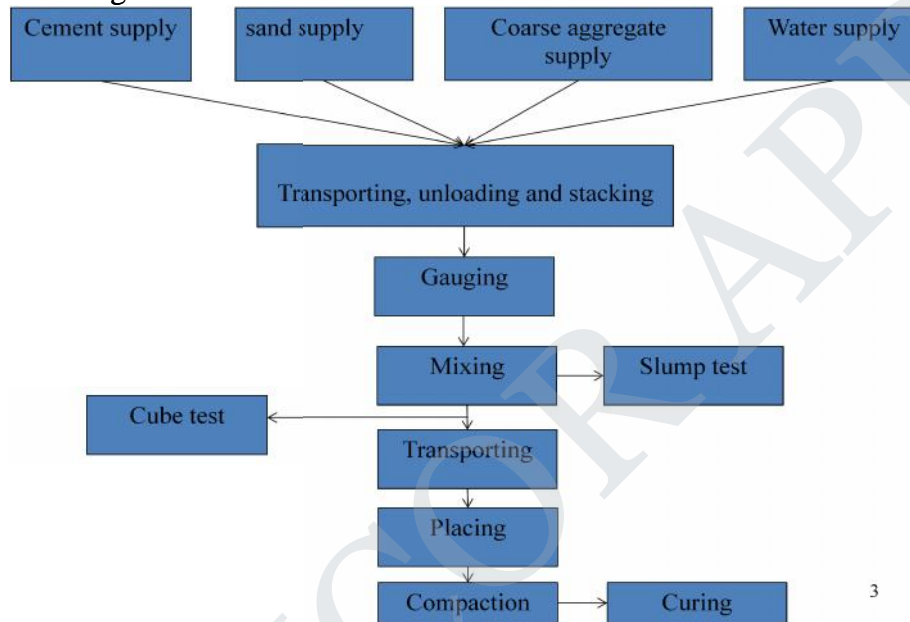

Batching of Materials

For good quality concrete a proper and accurate quantity of all the ingredients should be used. The aggregates, cement and water should be measured with an accuracy of ± 3 per cent of batch quantity and the admixtures by 5 per cent of the batch quantity. There are two prevalent methods of batching materials, the volume batching and the weigh batching. The factors affecting the choice of batching method are the size of job, required production rate, and required standards of batching performance. For most important works weigh batching is recommended.

- a) Volume Batching
- b) Weigh Batching

Mixing

1. Hand Mixing
2. Machine Mixing
 - a. Tilting Mixers

- b. Non-tilting Mixer
- c. Reversing Drum Mixer
- d. Pan-type or Stirring Mixer
- e. Transit Mixer

Charging the Mixer and Mixing Time

The order of feeding the ingredients into the mixer is as follows:

About 25 per cent of water required for mixing is first introduced into the mixer drum to prevent any sticking of cement on the blades and bottom of the drum. Then the ingredients are discharged through the skip. In the skip the sequence of loading should be to add first half the coarse aggregate then half the fine aggregate and over this total cement and then the balance aggregates. After discharging the ingredients into the drum the balance water is introduced. The mixing time is counted from the instant complete water is fed into the mixer.

The speed of the mixers is generally 15 to 20 rpm. For proper mixing, the number of revolutions per minute required by the drum are 25 to 30. Time of mixing also depends on capacity of mixer and is given in Table 10.3.

Table 10.3 Time of Mixing

Capacity of Mixer (cum)	Minimum mixing time (minutes)	
	Natural aggregates	Manufactured aggregates
3	2	2.5
2	1.5	2
1	1.25	1.5

A poor quality of concrete is obtained if the mixing time is reduced. On the other hand if the mixing time is increased it is uneconomical. However, it is found that if the mixing time is increased to 2 minutes the compressive strength of concrete produced is enhanced and beyond this time the improvement in compressive strength is insignificant. A prolonged mixing may cause segregation. Also, due to longer mixing periods the water may get absorbed by the aggregates or evaporate resulting in loss of workability and strength.

Transporting

Concrete should be transported to the place of deposition at the earliest without the loss of homogeneity obtained at the time of mixing. A maximum of 2 hours from the

time of mixing is permitted if trucks with agitator and 1 hour if trucks without agitators are used for transporting concrete. Also it should be ensured that segregation does not take place during transportation and placement. The methods adopted for transporting concrete depend upon the size and importance of the job, the distance of the deposition place from the mixing place, and the nature of the terrain. Some of the methods of transporting concrete are as below:

- a. Mortar Pan
- b. Wheel Barrow
- c. Chutes
- d. Dumper
- e. Bucket and Ropeway
- f. Belt conveyor
- g. Skip and Hoist
- h. Pumping

Placing

To achieve quality concrete it should be placed with utmost care securing the homogeneity achieved during mixing and the avoidance of segregation in transporting. Research has shown that a delayed placing of concrete results in a gain in ultimate compressive strength provided the concrete can be adequately compacted. For dry mixes in hot weather delay of half to one hour is allowed whereas for wet mixes in cold weather it may be several hours. The various situations in which concrete is placed are discussed below.

Foundations

Concrete foundations for walls and columns are provided below the ground surface. Before placing the concrete in the foundation all the loose earth, roots of trees etc., are removed. If the surface is found dry it is made wet so that earth does not absorb water from concrete. On the other hand if the foundation bed is wet the water and mud is removed and cement is sprinkled before placing concrete.

Beams, Columns, and Slabs

Before placing the concrete, the forms must be examined for correct alignment. They should be adequately rigid to withstand the weight of concrete and construction loads without undue deformation. Forms should be light enough to avoid any loss of mortar resulting in honeycombed concrete. The insides of the forms should be cleaned and oiled before use to avoid any sticking of concrete with the forms and making their stripping off difficult.

Concrete should not be dropped but placed in position to prevent segregation. It should

be dropped vertically from as small height as possible. It should be placed at one point in the formwork and allowed to flow side ways to take care of honeycombing.

Laitance formation should be avoided. It can be checked by restricting thickness of layer of concrete by 150–300 mm for R.C.C work. Laitance, however, if formed must be removed before placing the next layer of concrete. Several such layers form a lift, provided they follow one another quickly enough to avoid cold joints. The surface of the previous lift is kept rough and all the laitance removed before placing the next lift.

The reinforcement should be checked for tightness and clean surface. The loose rust or scales if any, are removed by wire brush. Paint, oil or grease if found should be removed. The minimum cover for reinforcement should be checked before concreting.

Mass Concreting

When the concrete is to be laid in mass as for raft foundation, dam, bridge, pier etc., concrete is placed in layers of 350–450 mm thickness. Several such layers placed in quick succession form a lift. Before placing the concrete in the next lift, the surface of the previous lift is cleaned thoroughly with water jets and scrubbing by wire brush. In case of dams, sand blasting is done.

The laitance and loose materials are removed and cement slurry is applied. When the concrete is subjected to lateral thrust, *bond bars* or *bond stones* are provided to form a key between different layers.

Concreting Highways and Runways

Concrete is laid in bays for highway, runway, or floor slabs. First the ground on which concrete is to be laid is prepared and all the loose materials and grass etc., are removed. The earth is wetted and compacted. The subgrades over which concrete is to be laid should be properly compacted and damped to avoid any loss of moisture from concrete. Concrete is then laid in alternate bays. This allows the concrete to undergo sufficient shrinkage and cracks do not develop afterwards. Concrete is not placed in heap at one place and then dragged, instead it is placed in uniform thickness.

Concreting Underwater

Concrete may be placed underwater with the help of bottom dump buckets. The concrete is taken through the water in water-tight bucket. On reaching the place of deposition the bottom of the bucket is made to open and the concrete is dumped. In this process certain amount of cement is washed away causing a reduction in strength of concrete. Another way of concreting underwater is by filling cement bag with dry or semi-dry mix of cement and aggregates and lowering them to the place of deposition. The draw back of this method is that the concrete will be full of voids interspersed with purticible gunny bags.

The best method of placing concrete underwater is by the use of *termie* pipe. The concrete is poured into it through funnel. The bottom end of the pipe is closed with a thick polythene sheet, with the bottom end of the pipe at the place of deposition. The concrete (slump 150–200 mm) is poured into funnel till the whole pipe is filled with concrete. The pipe is slightly lifted and given a jerk, the polythene sheet cover falls and concrete discharged. It should be ensured that the end of pipe remains inside the concrete so that water does not enter the pipe. The pipe is again filled with concrete through funnel and the process repeated till the concrete level comes above the water level. No compaction is required for underwater concrete as it gets compacted by the hydrostatic pressure of water. Concrete can also be placed underwater with the help of pipes and pumps.

Compaction

After concrete is placed at the desired location, the next step in the process of concrete production is its compaction. Compaction consolidates fresh concrete within the moulds or frameworks and around embedded parts and reinforcement steel. Considerable quantity of air is entrapped in concrete during its production and there is possible partial segregation also. Both of these adversely affect the quality of concrete. Compaction of the concrete is the process to get rid of the entrapped air and voids, elimination of segregation occurred and to form a homogeneous dense mass. It has been found that 5 per cent voids in hardened concrete reduce the strength by over 30 per cent and 10 per cent voids reduce the strength by over 50 per cent. Therefore, the density and consequently the strength and durability of concrete largely depend upon the degree of compaction. For maximum strength driest possible concrete should be compacted 100 per cent.

The voids increase the permeability of concrete. Loss of impermeability creates easy passage of moisture, oxygen, chlorides, and other aggressive chemicals into the concrete. This causes rusting of steel and spalling (disintegration) of concrete i.e., loss of durability. Easy entry of sulphates from the environment causes expansive reaction with the tricalcium aluminate (C_3A) present in cement. This causes disintegration of concrete and loss of durability. Entry of carbon dioxide causes carbonation of concrete i.e., loss of alkalinity of concrete or loss of the protective power that concrete gives to the reinforcement or other steel embedded in it. Once the carbonation depth exceeds the thickness of concrete cover to the embedded steel, steel becomes vulnerable to the attack of moisture. This expedites rusting of steel as the protective concrete cover remains no longer alkaline in nature.

Voids also reduce the contact between embedded steel and concrete. This results in loss of bond strength of reinforced concrete member and thus the member loses strength. Voids such as honeycombs and blowholes on the exposed surface produce visual blemish. Concrete surface is not good to look with all such blemishes. Concrete with smooth and perfect, surface finish not only looks good but is also stronger and more durable.

Compaction is achieved by imparting external work over the concrete to overcome the

internal friction between the particles forming the concrete, between concrete and reinforcement and between concrete and forms and by reducing the air voids to a minimum. The compaction of concrete can be achieved by the following methods.

1. Hand Compaction
2. Compaction by Vibration
 - a. Needle Vibrator:
 - b. Formwork Vibrator
3. Compaction by Spinning
4. Compaction by Jolting
5. Compaction by Rolling

Curing

Cement gains strength and hardness because of the chemical action between cement and water. This chemical reaction requires moisture, favourable temperature and time referred to as the curing period. The variation of compressive strength with curing period is shown in Fig. 10.11 (a, b). Curing of freshly placed concrete is very important for optimum strength and durability. The major part of the strength in the initial period is contributed by the clinker compound C_3S and partly by C_2S , and is completed in about three weeks. The later strength

contributed by C_2S is gradual and takes long time. As such sufficient water should be made available to concrete to allow it to gain full strength. *The process of keeping concrete damp for this purpose is known as curing.* The object is to prevent the loss of moisture from concrete due to evaporation or any other reason, supply additional moisture or heat and moisture to accelerate the gain of strength. Curing must be done for at least three weeks and in no case for less than ten days.

Approximately 14 litres of water is required to hydrate each bag of cement. Soon after the concrete is placed, the increase in strength is very rapid (3 to 7 days) and continues slowly thereafter for an indefinite period. Concrete moist cured for 7 days is about 50 per cent stronger

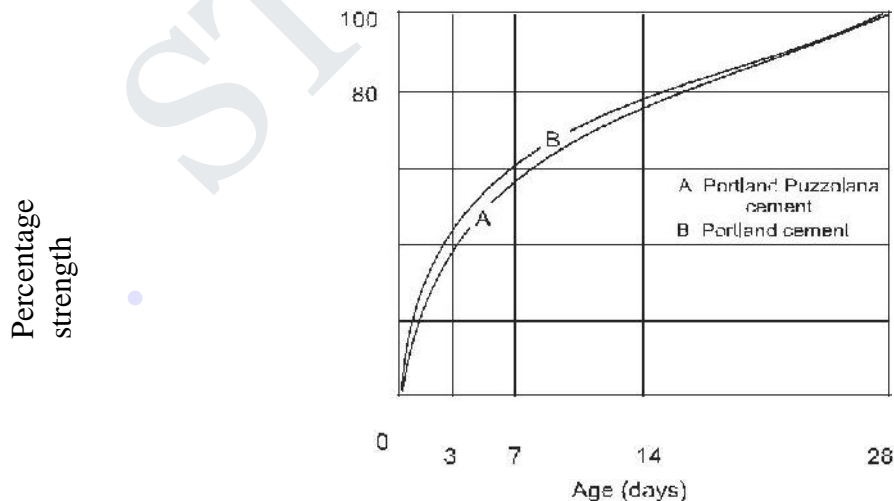

(a) Development of Strength with Age

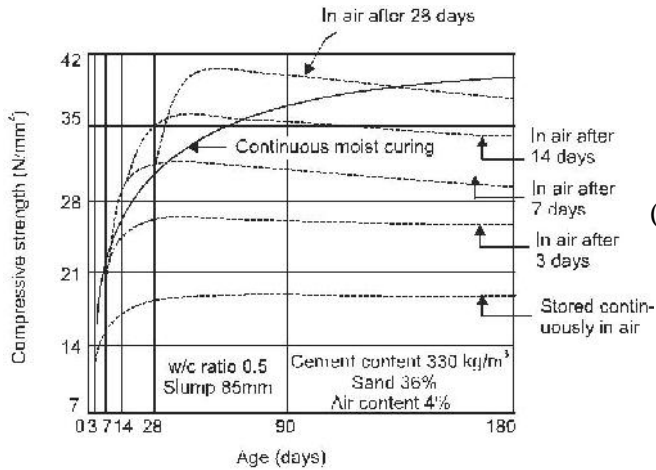

(b) Dried in Air after Preliminary Moist Curing

Fig. Development of Strength with Curing

than that which is exposed to dry air for the entire period. If the concrete is kept damp for one month, the strength is about double than that of concrete exposed only to dry air.

Methods of Curing

Concrete may be kept moist by a number of ways. The methods consist in either supplying additional moisture to concrete during early hardening period by ponding, spraying, sprinkling, etc. or by preventing loss of moisture from concrete by sealing the surface of concrete by membrane formed by curing compounds. Following are some of the prevalent methods of curing.

1. Water Curing
2. Steam Curing
3. Curing by Infra Red Radiation:
4. Electrical Curing
5. Chemical Curing:

Finishing

Concrete is basically used because of its high compressive strength. However, the finish of the ultimate product is not that pleasant. In past couple of decades efforts have been made to develop surface finishes to give a better appearance to concrete surfaces and are as follows.

1. Formwork Finishes
2. Surface Treatments
3. Applied Finishes

3.4 Ready Mixed Concrete (RMC)

Ready mixed concrete (RMC) is a concrete, delivered at site or into the purchaser's vehicle, in plastic condition and requires no further treatment before being

placed in a position in which it is to set and harden. It is a high quality concrete of required grade produced under strictly controlled conditions in a centralised automatic batching plant and supplied to the customer in a transit mixer truck for its placement at site. The concrete can be mixed either dry at the batching plant, loaded into agitator truck mixers and water added during transportation; or it can be mixed wet at the batching plant, discharged into the agitator truck mixers and transported to site. The first RMC plant was established in the year 1992 in Pune. At present, RMC plants are located in almost all the cities of India

Admixtures of RMC

Generally RMC is transported to sites which are located at long distances from the batching plants. At the delivery point, concrete should be workable and plastic. The transit period is sometimes four to five hours. The ordinary concrete will suffer slump loss due to the time lost in transit and evaporation of water due to atmospheric conditions such as high temperature. Therefore, admixtures will be required to extend the setting time and, retention of specified slump of concrete. Superplasticizers are, therefore, used to assure quality, workability, and strength of ready mixed concrete. Two types of admixtures are in use—the high performance water reducing admixtures and a high range water-reducing super-plasticizers. High performance water reducing admixtures have been specially designed to retain workability even in high ambient temperature. The examples are conplast RMC P 333 and conplast RMC P 505. The advantages of using high performance water reducing admixtures are:

1. Improved cohesion and reduced bleeding and segregation.
2. Makes the mix cohesive even if the aggregates are of slightly poor grading.
3. Since chloride free it is safe for use in reinforced and prestressed concrete.
4. Improved workability and workability retention with controlled extended setting time and hence ideal for use in hot weather condition.
5. Workability increases without extra water addition.
6. Assists in producing dense, close textured, low permeability concrete thus enhancing durability.
7. Water reduction helps in improvement of compressive strength at all ages.

Advantages of RMC

1. Enhanced quality and durability resulting in lower maintenance costs and increased speed of construction.
2. Ready mix concrete is consistently of the same quality and provides a high quality of construction material; construction time is also reduced.
3. It reduces congestion at the site and prevents traffic jams.
4. It hastens infrastructure development and thus provides more employment opportunities.
5. It is an environmentally safer alternative.
6. With ready mixed concrete, modern construction techniques can be followed.
7. Convenience—Ready Mix Concrete is delivered at the site with minimum logistical hassles.

8. Different types of concretes can be made for different applications.

9. Use of RMC obviates the need to set up the infrastructure required for site manufactures

of concrete. This also reduces the working capital to be invested by the customers, as they

will not be required to maintain stock of aggregates, cement, plant and machinery etc.

3.5 Properties of Fresh Concrete:

Significance:

The first 48 hours are very important for the performance of the concrete structure.

It controls the long-term behavior, influence f'_c (ultimate strength), E_c (elastic modulus), creep, and durability.

Properties of Fresh Concrete :

Properties at Early Ages :

- Workability
- Slump Loss
- Segregation/Bleeding
- Plastic Shrinkage
- Time of Set

Workability :

→ Definition: Effort required to manipulate a concrete mixture with a minimum of segregation.

It is not a fundamental property of concrete.

I) **consistency** (slump)-- easy to flow

II) **cohesiveness** --tendency to bleed and segregate

Slump Test:

→ Slump test is a test conducting before concrete to be used for casting. The purpose of slump test Is to determine the water content in concrete and its workability

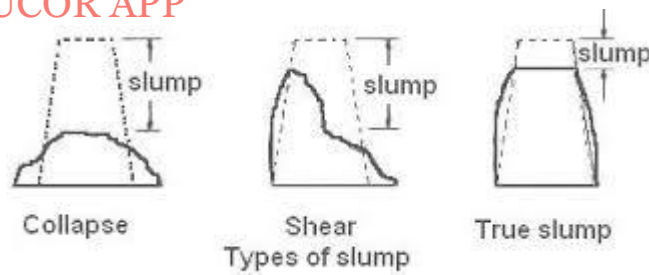

Consistency:

→ Consistency or fluidity of concrete is an important component of workability and refers in a way to the wetness of the concrete.

However, it must not be assumed that the wetter the mix the more workable it is. If a mix is too wet, segregation may occur with resulting honeycomb, excessive bleeding, and sand streaking on the formed surfaces.

On the other hand, if a mix is too dry it may be difficult to place and compact, and segregation may occur because of lack of cohesiveness and plasticity of the paste.

3.6 Properties Of Hardened Concrete

➤ The principal properties of hardened concrete which are of practical importance can be listed as:

1. Strength
2. Permeability & durability
3. Shrinkage & creep deformations
4. Response to temperature variations

Of these compressive strength is the most important property of concrete. Because Of the abovementioned hardened properties compressive strength is one of the most important property that is often required, simply because;

1. Concrete is used for compressive loads
2. Compressive strength is easily obtained
3. It is a good measure of all the other properties.

Compressive Strength is determined by loading properly prepared and cured cubic, cylindrical or prismatic specimens under compression.

- Cubic: 15x15x15 cm

Cubic specimens are crushed after rotating them 90° to decrease the amount of friction caused by the rough finishing.

- Cylinder: $h/D=2$ with $h=15$

To decrease the amount of friction, capping of the rough casting surface is performed.

3.7 Mix Design

- Mix design is the process of selecting suitable ingredients of concrete & determining their relative quantities with the objective of producing as economically as possible concrete of certain minimum properties such as workability, strength & durability.
- So, basic considerations in a mix design is cost & min. properties.

The Principles of Proportioning: The fundamental object in proportioning concrete or mortar mixes is the production of a durable material of requisite strength, watertightness, and other essential properties at minimum cost. To achieve these objectives, careful attention must be given to the selection of cement, aggregate, and water to the following considerations:

1. The mix must be workable so that it can be placed and finished without undue labour.
2. Since cement is the most costly ingredient in the mix, the proportion used should be as small as is consistent with the attainment of desired properties. Within wide limits, experiments have shown:
 - (a) The strength and degree of watertightness of mixes, having like constituent materials, density, and workability, increase with the cement content.
 - (b) With the cement content, materials, and workability all constant, the strength and degree of watertightness increase with the density of the mix.
 - (c) For usual methods of placement, the strength and degree of watertightness of well-cured concrete and mortar are greatest when the mix is plastic (has a slump of approximately 50 mm). Drier mixes, although frequently as strong, are likely to be porous unless compacted by pneumatic rammers or electrically driven vibrators. Increasing the water content beyond that required for plasticity causes the strength to decrease rapidly.
 - (d) Concrete with 4–7 per cent, by volume, entrained air made by using an air-entraining cement or by adding air-entraining admixtures is more resistant to freezing and thawing action and also to scaling due to the use of salt for ice removal than concrete made with regular cement and without air-entraining admixtures.
In addition to the above, the following statements appear to be justified by the results of experience and tests:
 - (e) To proportion concrete for the maximum resistance to fire, a porous non-combustible aggregate of high specific heat together with cement sufficient to provide the requisite strength should be thoroughly mixed and placed with as little ramming as possible to produce a porous concrete.

- (f) In proportioning concrete or mortar which is to be subjected to freezing temperatures shortly after placement, a minimum amount of water and a quick-setting cement should be used.
- (g) Concrete for road construction should be made from a carefully graded, hard tough aggregate bound together with as small a proportion of rich mortar as is consistent with the required workability, strength, and imperviousness. In locations where resistance to freezing and thawing is required, the concrete should have 3–6 per cent of entrained air. The principal methods used in scientific proportioning of mixes are based upon relationships between properties and ratio of cement to voids in the mix, or on the relationship between properties and the ratio of water to cement in the mix.

3.8 High Strength Concrete

For mix made with normal weight aggregates, high strength concrete (HSC) is considered to be the one having a compressive strength in excess of 40 MPa. To produce concrete above this strength more stringent quality control and more care in selection and proportioning of materials are needed. The tentative classification of HSC is as given in Table 20.5. The tricalcium aluminate component is kept as low as possible (<8%). Most cements used to produce HSC have fineness in the range of 300–400 m²/kg with an exception of high early strength cement for which fineness should be at least 450 m²/kg. For HSC a smaller maximum size of coarse aggregate leads to higher strength. Fine aggregate should have a F.M >3.

3.9 High Performance Concrete

High-performance concrete (HPC) is relatively new technology. HPC originated in France in 1980, followed by Canada in 1990. In 1989, under the direction of Paul Zia of North Carolina State University, a major effort in HPC technology began in the United States with the initiation of the Strategic Highway Research Program (SHRP). SHRP defined HPC in terms of strength, low w/c, and freeze/thaw durability. These early efforts were in response to alarming deterioration rates of the nation's roads and bridges. The concept of HPC has certainly evolved with time. What exactly is "high-performance?" Various parameters have been attached to HPC, with high strength being a popular descriptor. While equating HPC with high strength certainly has some merit, it doesn't present a complete or, in some cases, accurate picture. Other properties of the concrete must also be considered, and may even override the strength issue. Three influences must be considered: the structure in which the concrete will be used, including support; the environment in which the structure will be placed; and the type and number of forces to which the structure will be subjected. These considerations are discussed in detail, before defining HPC.

- Fresh concrete that can flow around reinforcement and consolidate within formwork under its own weight that exhibits no defects due to segregation or bleeding.
- The guiding principle for this type of concrete is that the sedimentation velocity of a particle is inversely proportional to the viscosity of the floating medium in which the particle exists.

Benefits of SCC

- Faster construction
- Reduction in site manpower
- Safer working environment
- Improved aesthetics
- Easier placing
- Improved durability

Applications

- Two anchorages of Akashi-Kaikyo (Straits) Bridge, Japan. The volume of the cast concrete in the two anchorages amounted to 290,000 m³
- The highest use of SCC in India was done at Delhi metro project. About 10000 m³ of SCC has been Used.
- At Kaiga nuclear power plant, SCC of Characteristic strength 30 MPa was used.

3.11 Durability of Concrete

A durable concrete is one that performs satisfactorily under anticipated exposure conditions for stipulated life of the structure. The various factors affecting the durability of concrete used in normal conditions are as follows:

Permeability Almost all forms of deterioration in concrete are due to ingress of water. The ways in which durability of concrete may be affected because of permeability are:

1. The chemicals in liquid form affect the concrete by penetrating it.
2. Frost action, rusting of steel, etc.

Concrete has gel pores and capillary cavities. About 1/3 of gel pores are so small that they hardly pass any water through them. The extent of capillary cavities, which depends on the w/c ratio, is the major factor contributing to permeability. The remedies are:

1. Use of pozzolanic materials.

2. Air entrainment up to 6 per cent.
3. High pressure steam curing in conjunction with silica.

Frost Action: The concrete may be affected due to being permeable or by temperature below 0°C . The mechanism of attack is attributed to the expansion of absorbed water on freezing. Damage can also result from movement of water within concrete on cooling below 0°C . Ice builds up in large pores causing large expansion in local areas the others being dry cause disintegration. The conditions favouring frost attack are:

1. Horizontal surfaces open to sky absorbing more water in wet conditions and cooling quicker by radiation.
2. Low temperatures increasing the extent of migration of water resulting in freezing to greater depths in the concrete.
3. Repeated freezing and thawing.
4. Use of de-icing salts.

STUCOR APP

Timber And Other Materials

Timber – Market forms – Industrial timber– Plywood – Veneer – Thermacole – Panels of laminates – Steel – Aluminum and Other Metallic Materials – Composition – Aluminium composite panel –Uses – Market forms – Mechanical treatment – Paints – Varnishes – Distempers – Bitumens.

4.1 Timber

4.2 Market Forms of Timber

The followings are the various types of market forms of timber.
1.Log 2.Lumber 3.Bilk 4.Deal 5.Batten 6.Plank 7.Board 8.Scantline 9 .Pole

4.3 Plywood

Plywood is a sheet material manufactured from thin layers or "plies" of wood veneer that are glued together with adjacent layers having their wood grain rotated up to 90 degrees to one another. It is an engineered wood from the family of manufactured boards which includes medium-density fibreboard (MDF) and particle board (chipboard).

All plywoods bind resin and wood fiber sheets (cellulose cells are long, strong and thin) to form a composite material. This alternation of the grain is called cross-graining and has several important benefits: it reduces the tendency of wood to split when nailed at the edges; it reduces expansion and shrinkage, providing improved dimensional stability; and it makes the strength of the panel consistent across all directions. There are usually an odd number of plies, so that the sheet is balanced—this reduces warping. Because plywood is bonded with grains running against one another and with an odd number of composite parts, it is very hard to bend it perpendicular to the grain direction of the surface ply.

Smaller thinner plywoods and lower quality plywoods (see Average-quality plywood photo below and right) may only have their plies (layers) arranged at right angles to each other, though many better quality plywood products will by design have five plies in steps of 45 degrees (0, 45, 90, 135, and 180 degrees), giving strength in multiple axis. The highest quality specialty plywoods often have plies at 30 degrees (0, 30, 60, 90, 120, 150, and 180 degrees) in seven layers, or have nine layers with two layers of 45 and 135 degrees in the sandwich. The smaller the step rotations the harder it is to manufacture, increasing manufacturing costs and consequently retail price

4.3.1 Types

Different varieties of plywood exist for different applications:

- a) Softwood plywood Hardwood plywood

- b) Tropical plywood
- c) Aircraft plywood
- d) Decorative plywood (overlaid plywood)
- e) Flexible plywood
- f) Marine plywood
- g) Other plywoods

4.3.2 Grades

Grading rules differ according to the country of origin. Most popular standard is the British Standard (BS) and American Standard (ASTM). Joyce (1970), however, list some general indication of grading rules:

Grade Description

- A Face and back veneers practically free from all defects.
- A/B Face veneers practically free from all defects. Reverse veneers with only a few small knots or discolorations.
- A/BB Face as A but reverse side permitting jointed veneers, large knots, plugs, etc.
- B Both side veneers with only a few small knots or discolorations.
- B/BB Face veneers with only a few small knots or discolorations. Reverse side permitting jointed veneers, large knots, plugs, etc.
- BB Both sides permitting jointed veneers, large knots, plugs, etc.
- WG Guaranteed well glued only. All broken knots plugged.
- X Knots, knotholes, cracks, and all other defects permitted.

JPIC Standards

Grade Description

Face as BB, back as CC. BB as very little knots of less than 1/4 inches, slight BB/CC discoloration, no decay, split and wormholes mended skillfully, matched colors, no blister, no wrinkle. Most popular choice for most applications.

4.3.3 Applications

Plywood is used in many applications that need high-quality, high-strength sheet material. Quality in this context means resistance to cracking, breaking, shrinkage, twisting and warping.

Exterior glued plywood is suitable for outdoor use, but because moisture affects the strength of wood, optimal performance is achieved in end uses where the wood's moisture content remains relatively low. On the other hand, subzero conditions don't affect plywood's dimensional or strength properties, which makes some special applications possible.

Plywood is also used as an engineering material for stressed-skin applications. It has been used for marine and aviation applications since WWII. Most notable is the British de Havilland Mosquito bomber, which was primarily made using a moulded sandwich of two layers of birch plywood around a balsa core. Plywood was also used for the hulls in the hard-chine Motor Torpedo Boats (MTB) and Motor Gun Boats (MGB) built by the British Power Boat Company and Vosper's. Plywood is currently successfully used in stressed-skin applications.^[citation needed] The American designers Charles and Ray Eames are famous for their plywood-based furniture, as is Finnish Architect Alvar Aalto and his firm Artek, while Phil Bolger is famous for designing a wide range of boats built primarily of plywood.

Plywood is often used to create curved surfaces because it can easily bend with the grain. Skateboard ramps often utilize plywood as the top smooth surface over bent curves to create transition that can simulate the shapes of ocean waves.

Softwood plywood applications

Typical end uses of spruce plywood are:

- Floors, walls and roofs in home constructions
- Wind bracing panels
- Vehicle internal body work
- Packages and boxes
- Fencing

There are coating solutions available that mask the prominent grain structure of spruce plywood. For these coated plywoods there are some end uses where reasonable strength is needed but the lightness of spruce is a benefit e.g.:

- Concrete shuttering panels
- Ready-to-paint surfaces for constructions

Hardwood plywood applications

Phenolic resin film coated (Film Faced) plywood is typically used as a ready-to-install component e.g.:

- Panels in concrete form work systems
- Floors, walls and roofs in transport vehicles
- Container floors
- Floors subjected to heavy wear in various buildings and factories
- Scaffolding materials

("Wire" or other styles of imprinting available for better traction)

Birch plywood is used as a structural material in special applications e.g.:

- Wind turbine blades
- Insulation boxes for liquefied natural gas (LNG) carriers

Smooth surface and accurate thickness combined with the durability of the material makes birch plywood a favorable material for many special end uses e.g.:

- High-end loud speakers
- Die-cutting boards
- Supporting structure for parquet
- Playground equipment
- Furniture
- Signs and fences for demanding outdoor advertising
- Musical instruments
- Sports equipment

Tropical plywood applications

Tropical plywood is widely available from the South-East Asia region, mainly from Malaysia and Indonesia. Tropical plywood boasts premium quality, and strength. Depending on machinery, tropical plywood can be made with high accuracy in thickness, and is a highly preferable choice in America, Japan, Middle East, Korea, and other regions around the world.

- Common plywood
- Concrete panel
- Floor base
- Structure panel
- Container flooring
- Lamin board
- Laminated veneer lumber (LVL)

In woodworking, **veneer** refers to thin slices of wood, usually thinner than 3 mm (1/8 inch), that typically are glued onto core panels (typically, wood, particle board or medium-density fiberboard) to produce flat panels such as doors, tops and panels for cabinets, parquet floors and parts of furniture. They are also used in marquetry. Plywood consists of three or more layers of veneer, each glued with its grain at right angles to adjacent layers for strength. Veneer beading is a thin layer of decorative edging placed around objects, such as jewelry boxes. Veneer is also used to replace decorative papers in Wood Veneer HPL. Veneer is also a type of manufactured board.

4.4 Veneer

Veneer is obtained either by "peeling" the trunk of a tree or by slicing large rectangular blocks of wood known as flitches. The appearance of the grain and figure in wood comes from slicing through the growth rings of a tree and depends upon the angle

at which the wood is sliced. There are three main types of veneer-making equipment used commercially:

- A rotary lathe in which the wood is turned against a very sharp blade and peeled off in one continuous or semi-continuous roll. Rotary-cut veneer is mainly used for plywood, as the appearance is not desirable because the veneer is cut concentric to the growth rings.
- A slicing machine in which the flitch or piece of log is raised and lowered against the blade and slices of the log are made. This yields veneer that looks like sawn pieces of wood, cut across the growth rings; such veneer is referred to as "crown cut".
- A half-round lathe in which the log or piece of log can be turned and moved in such a way as to expose the most interesting parts of the grain.

4.4.1 Types of veneers

There are a few types of veneers available, each serving a particular purpose.

- **Raw** veneer has no backing on it and can be used with either side facing up. It is important to note that the two sides will appear different when a finish has been applied, due to the cell structure of the wood.
- **Paper backed** veneer is as the name suggests, veneers that are backed with paper. The advantage to this is it is available in large sizes, or sheets, as smaller pieces are joined together prior to adding the backing. This is helpful for users that do not wish to join smaller pieces of raw veneers together. This is also helpful when veneering curves and columns as the veneer is less likely to crack.
- **Phenolic backed** veneer is less common and is used for composite, or manmade wood veneers. Due to concern for the natural resource, this is becoming more popular. It too has the advantage of being available in sheets, and is also less likely to crack when being used on curves.
- **Laid up** veneer is raw veneer that has been joined together to make larger pieces. The process is time-consuming and requires great care, but is not difficult and requires no expensive tools or machinery. Veneers can be ordered through some companies already laid up to any size, shape or design.
- **Reconstituted veneer** is made from fast-growing tropical species. Raw veneer is cut from a log, and dyed if necessary. Once dyed, the sheets are laminated together to form a block. The block is then sliced so that the edges of the laminated veneer become the "grain" of the reconstituted veneer.
- **Wood on Wood** Also called 2-ply is a decorative wood veneer face with a utility grade wood backer applied at an opposing direction to the face veneer. ^[1]

4.4.2 Advantages of using veneers

Furniture made with wood veneer uses less wood than the same piece of furniture made with solid wood. Some projects built using wood veneer would not be possible to

construct using solid lumber, owing to expansion and contraction caused by fluctuation of temperature and humidity.

4.5 Thermocol

Thermocol is a light and cellular plastic material used for sound and heat insulation of ceiling, walls, refrigerators and for air conditioning of the buildings. It is soft, light, strong and durable having compressive strength in the range of 11.7 to 14.4 N/mm². It has excellent heat, sound and electric insulating properties.

4.6 Panels of Laminates

Laminate panel is a type of manufactured timber made from thin sheets of substrates or wood veneer. It is similar to the more widely used plywood, except that it has a plastic, protective layer on one or both sides. Laminate panels are used instead of plywood because of their resistance to impact, weather, moisture, shattering in cold (ductility), and chemicals.

Laminate panel layers (called veneers) are glued together with adjacent plies having their grain at right angles to each other for greater strength. The plastic layer(s) added for protection vary in composition, thickness, color and texture according to the application.

4.6.1 Types

A number of varieties of laminate panel exist for different applications.

- Plywood + ABS laminate panels
- Plywood + FRP laminate panels
- Plywood + aluminum laminated panels
- Lightweight composite panels

4.6.2 Sizes

The most commonly used thickness range from 1/8" to 1/2" and 3/8", in a variety of colours and textures.

4.6.3 Applications

Laminate panels are used in many applications that need weather-proof, impact resistant sheet material. Typical end uses of spruce plywood are:

- Floors, walls and roofs in cleanrooms
- Vehicle internal body work
- Packages and boxes
- Road cases

Steel is the most suitable building material among metallic materials. This is due to a wide range and combination of physical and mechanical properties that steels can have. By suitably controlling the carbon content, alloying elements and heat treatment, a desired combination of hardness, ductility, and strength can be obtained in steel. On the basis of carbon content steel may be classified as under:

Type of steel	Carbon content (%)
Dead mild steel	< 0.15
Mild steel	0.15–0.3
Medium carbon steel	0.3–0.8
High carbon steel or hard steel	0.8–1.5 (> 1 is also called cast steel or tool steel)

4.7.1 Manufacturing Methods

The prominent steel-making processes are:

1. Bessemer process
2. Cementation process
3. Crucible process
4. Open Hearth process
5. Electric Smelting process
6. Duplex process
7. Lintz and Donawitz (L.D.) process

The most prominent present-day steel-making process is the Bessemer process was introduced in 1856. The pig iron is first melted in Cupola furnace and sent to Bessemer converter (Fig.) Blast of hot air is given to oxidize the carbon. Depending upon the requirement, some carbon and manganese is added to the converter and hot air is blasted once again. Then the molten material is poured into moulds to form ingots. L.D. process is

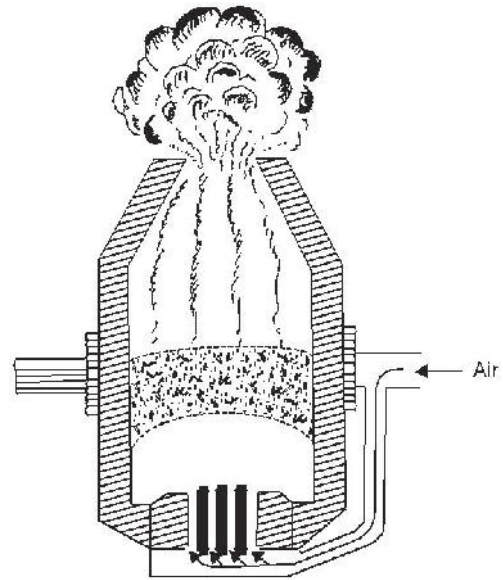

Fig. Bessemer Converter for the Manufacture of Steel

modification of the Bessemer process in which there is no control over temperature. By this method steel can be made in hardly 25 minutes. In Open-hearth process also known as Siemen's-Martin process, the steel produced is more homogeneous than by Bessemer's. The electric

process is costly but no ash or smoke is produced. The Crucible process involves melting of blister steel or bars of wrought iron in fire clay crucibles. Cast steel so obtained is very hard and is used for making surgical equipments. The Duplex process is a combination of Acid Bessemer process and Basic Open Hearth process

4.7.2 Properties and Uses

Mild Steel Also known as low carbon or soft steel. It is ductile, malleable; tougher and more elastic than wrought iron. Mild steel can be forged and welded, difficult to temper and harden. It rusts quickly and can be permanently magnetized. The properties are: Sp. gr. = 7.30, ultimate compressive and tensile strengths $800\text{--}1200\text{N/mm}^2$ and $600\text{--}800\text{N/mm}^2$.

Mild steel is used in the form of rolled sections, reinforcing bars, roof coverings and sheet piles and in railway tracks.

High Carbon Steel: The carbon content in high carbon steel varies from 0.55 to 1.50%. It is also known as hard steel. It is tougher and more elastic than mild steel. It can be forged and welded with difficulty. Its ultimate compressive and tensile strengths are 1350 N/mm^2 and $1400\text{--}2000\text{ N/mm}^2$, respectively. Its Sp. gr. is 7.90.

High carbon steel is used for reinforcing cement concrete and prestressed concrete members. It can take shocks and vibrations and is used for making tools and machine parts.

High Tensile steel: The carbon content in high tensile steel is 0.6–0.8%, manganese 0.6%, silicon 0.2%, sulphur 0.05% and phosphorus 0.05%. It is also known as high strength steel and is essentially a medium carbon steel. The ultimate tensile strength is of the order of 2000 N/mm^2 and a minimum elongation of 10 per cent. High Tensile steel is used in prestressed concrete construction.

4.7.3 Properties of Steel

The factors influencing the properties of steel are chemical composition, heat treatment, and mechanical work.

Chemical Composition

The presence of carbon in steel gives high degree of hardness and strength. The addition of carbon to iron decreases the malleability and ductility of the metal, and reduces its permeability to magnetic forces.

The tensile strength of hot rolled steel bars is maximum between 1.0 and 1.2 per cent carbon. The elastic limit and the ultimate strength of steel increase with carbon content but at a lower rate. The compressive strength of steel increases directly with carbon content up to 1.0 per cent. The shear strength of steel also increases with the carbon content. The ratio of shear strength to the tensile strength is 0.80 for medium and low carbon steels and 0.60 for high carbon steels. The modulus of elasticity is nearly same for tension and compression and is practically independent of the carbon content.

The ductility of steel decreases markedly as the carbon content increases. The resistance of steel to heavy shocks or blows decreases with increase of carbon content.

Effects of Principal Impurities on Steel: It is not feasible to entirely remove impurities in making either iron or steel. The final product always contains small percentages of the metallic impurities like silicon, manganese, sulphur, and phosphorus besides iron and carbon. Occasionally small percentages of copper and arsenic are also present. In well made steel these impurities generally range between 0.2 and 1.0 per cent and their resultant effect on the constitution of steel is often small. Of the common impurities, Phosphorus cannot be eliminated in the process of manufacture, whereas most of the silicon and manganese are introduced to improve the metal.

Silicon is often added to molten metal to remove oxygen and diminish blow holes. In structural steel it rarely exceeds 0.25 per cent. Silicon up to 1.75 per cent appears to increase both ultimate strength and elastic limit without decreasing ductility.

Phosphorus is considered to promote enlargement of the grains and thus produce brittleness. The ductility of low-carbon steel decreases slightly by the presence of 0.3–0.5 per cent phosphorus. However, yield point, ultimate strength and hardness of steel are increased. Resistance to shock is also reduced by 0.1 per cent phosphorus and the metal is rendered cold short (i.e., brittle when cold). A decrease in toughness appears to be more pronounced in high-carbon than in low-carbon steels. The maximum limits for phosphorus are: for inferior grades of structural steel 0.1, for best grades of structural steel 0.055, and 0.02 per cent for tool steels.

Sulphur readily combines with iron to form iron sulphide (FeS) which, when present in iron or steel, has a tendency to segregate and form brittle networks at the grain boundaries. On account of its low melting point, iron sulphide causes lack of cohesion between adjacent grains when heated above a red heat. Such brittleness at high temperature is termed as red shortness which makes steel or iron hard to roll or forge. Manganese sulphide has a much higher melting point than iron sulphide and does not render ferrous metals red short. Therefore, inasmuch as manganese has a very powerful affinity for sulphur, it is possible to relieve red shortness by adding sufficient quantity of manganese to the molten metal to combine with sulphur. Theoretically the ratio of manganese to sulphur should be 1.70 to 1.0 in order to form manganese sulphide and completely satisfy sulphur. Less than 0.15 per cent sulphur content hardly exercises any appreciable effect on the mechanical properties of steel. When sulphur is present along with manganese it improves the machineability of steel.

Manganese has strong affinity for oxygen and sulphur and acts as a cleanser of the molten metal by withdrawing much of the undesirable impurities into the slag. Manganese increases the tensile strength, hardenability and dilutes the effect of sulphur. When more manganese is present than required for sulphur and oxygen the excess manganese forms carbide and acts as hardener. Copper increases resistance to corrosion when present in small percentage. Arsenic has a tendency to raise the strength and

brittleness. Non-metallic Impurities are mechanically suspended in the metal and are often called slag inclusions causing brittleness.

Heat Treatment

The object of heat treatment is to develop desired properties in steel. The properties of steel can be controlled and changed as well by various heat treatments. A steel of given composition may be made soft, ductile and tough by one heat treatment, and the same steel may be made relatively hard and strong by another. Heat treatment affects the nature, amount, and character of the metallographic properties.

Heat treatment influences the solubility relations of the constituents, changes the crystallization either with respect to form or degree of aggregation and introduces or relieves internal stresses in the metal. The heat treatment process consists in subjecting, a metal to definite temperature–time course.

Some of the principle purposes of heat treatment are as follows.

1. To enhance properties such as strength, ductility, hardness and toughness.
2. To relieve internal stresses and strains.
3. To refine the grain.
4. To remove gases.
5. To normalize steel after heat treatment.

Hardening

This heat treatment consists of heating the steel above the upper critical temperature holding at that temperature until phase equilibrium has been established, and then quenching rapidly to produce a martensite structure. Martensite is the chief constituent of hardened steel and is fibrous or needle like structure. Hardened steel is very brittle and cannot be used for practical purposes. The quenching medium is usually brine, water or oil, depending on the desired cooling rate.

The objective of this treatment may be to secure a given hardness to a desired depth in steel. But in most instances the hardening treatment may simply be considered as starting point from which better combinations of desired properties may be secured by subsequent heat treatment. Fully hardened steel are not suitable for most commercial uses because they are hard and brittle and have poor toughness.

Tempering

A plain carbon steel that has been hardened is in metastable condition or equilibrium. If this hardened steel is reheated to some temperature below the critical range, a more stable condition will be obtained. Since hardened steels do not usually have the combination of properties desired for specific uses, modification is affected by tempering.

When a thick piece of steel is cooled rapidly it develops additional strains as the surface cools quicker than the interior. To relieve this strain, steel is subjected to the process tempering which consists in slowly heating the steel to a predetermined subcritical temperature and then cooling it slowly. This temperature varies from 100°C to 700°C. The higher the temperature of tempering the softer is the product. The properties like toughness and ductility are automatically introduced with release of strain.

Annealing

It is a general term used for heating and slow cooling of metal, glass or any other material, which has developed strain due to rapid cooling.

The process consists of heating the steel to a temperature below the critical range, but high enough to obtain strain re-crystallization and then cooled in any manner. The exact heating temperature depends on the composition of steel and the amount of work that it has received, but is frequently between 500°C to 600°C. Annealing of steel in addition to removing strain introduces one or more of the following properties.

1. Introduces softness, ductility, and malleability.
2. Alters electrical, magnetic, and other physical properties.
3. Produces a definite microstructure and grain refinement.
4. Removes gases.

Full annealing consists of heating iron alloy 20°C to 50°C above critical temperature range, holding at that temperature for the required period of time to convert it to austenite followed by slow cooling. Full annealing usually decreases hardness, strength, and resistance to abrasion, and increases ductility and merchantability.

Normalizing

It consists in heating steel above critical range and cooling rapidly in air, but at rate slower than the critical cooling rate. The purpose of this heat treatment is to refine the grain structure resulting from rolling, forging or other manufacturing processes.

Mechanical Works

Steel products are made by casting molten refined steel of suitable composition into the desired form or by mechanically working steel from the ingot through many intermediate forms to the desired product. Mechanical work may be hot or cold. Mechanical working involves many stages of hot working and may or may not include eventual cold working.

The most important methods of hot working steel are hot rolling, hammer forging, hydraulic and mechanical press forging, and hot extrusion. Miscellaneous hot working methods include hot spinning, hot deep drawing, hot flanging and hot bending. Heat treatment after hot working is seldom used with low-carbon steels, whereas high-carbon steels are always hardened and tempered.

The principle methods of cold working steel are cold rolling, cold drawing and cold extrusion. The cold working methods are used to provide increased strength, accurate dimensions, and bright and scale free surfaces. Thin sheets and small diameter wires are produced by cold-working methods. Cold working results in increased density, hardness,

and brittleness, and produces an internally strained condition in the steel.

Mechanical work alters the form of the crystalline aggregate and introduces internal stresses. Cold rolling increases the tensile elastic limit from 15 to 97 per cent and tensile strength from 20 to 45 per cent. In elastic resilience the cold-rolled metal is superior to the hot-rolled, whereas in energy of rupture it is inferior to the hot-rolled metal. The modulus of elasticity is slightly increased by cold rolling. Practically, metals are rolled, forged, drawn, stamped and pressed.

Most of steel building components—beams, rails, steels, bars, reinforcement, pipes—are manufactured by rolling. Rivets and bolts are made by forging operations. Thin-walled items (tubes) and round, square, hexagonal rods of small cross-sectional areas (up to 10 mm²) are manufactured by drawing. Stamping and pressing increases the buckling strength of plates to be used for making them suitable for steel tanks and containers. Steel trusses, towers, tanks, bridges and frames of multistorey buildings are some of the examples of structures made of steel. The most common and important application of steel in buildings is the rolled steel sections and reinforcing bars and are described in the following sections.

4.8 Aluminum

The principal constituents of bauxite (Al₂O₃·2H₂O) which yield aluminum on a commercial scale are hydrated oxides of aluminum and iron with some silica. Some of the other aluminum ores are corundum, kaolin or china clay, and kryolite. The ore is purified by Bayer's process and is reduced to aluminum by Hall Hiroult's process in two stages. In the first stage bauxite is converted into alumina by roasting, grinding, heating (with sodium hydrate) and filtering. Then it is agitated for several hours to precipitate the hydrate, which is separated, washed, and calcined at 1000° C. In the next stage aluminum is extracted by electrolysis of alumina in a molten bath (Fig. 14.1) of crysolite (a fluoride of alumina and sodium). A flow diagram for extraction of aluminium is shown in Fig.

Aluminum is silver white in colour with a brittle metallic lustre on freshly broken surface. It is malleable, less ductile than copper but excels zinc, tin, and lead. Aluminium is harder than tin. Aluminium is very light, soft, strong and durable, has low thermal conductivity but is a good conductor of electricity. Aluminium can be riveted and welded, but cannot be soldered. It can be tempered at 350° C. The melting point is 657° C, tensile strength is 117.2 N/mm² in the cast form and 241.3 N/mm² when drawn into wires. Aluminium is found to be resistant

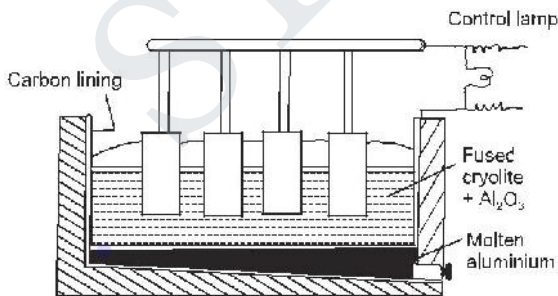

Fig. Extraction of Aluminum by Electrolysis

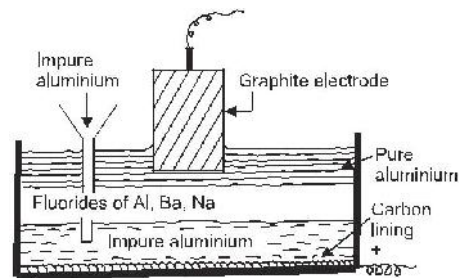

Fig. Hoop's Cell for Refining Aluminum

to the attack of nitric acid, dissolves slowly in concentrated sulphuric acid and is soluble in hydrochloric acid. At normal temperature it is not affected by sulphur, carbonic acid, carbonic oxide, vinegar, sea water, etc., but is rapidly corroded by caustic alkalis.

Uses Pure aluminum is very soft and is unsuitable for structural purposes. Satisfactory properties are derived by alloying copper, manganese, zinc, silicon, nickel with aluminum. It is most suitable for making door and window frames, railings of shops and corrugated sheets for roofing system. Aluminum sheets are used over doors in bathrooms to protect them from getting rot and for stamping into a variety of shapes. Aluminum powder is used for making paint. Aluminum is extensively used in making parts of internal combustion engine, airplanes, utensils and packing for medicines, chocolates, etc. Aluminum alloys are widely used for the manufacture of rolled sections, such as angles, channels, I-sections, round and rectangular pipes, rivets, and bolts

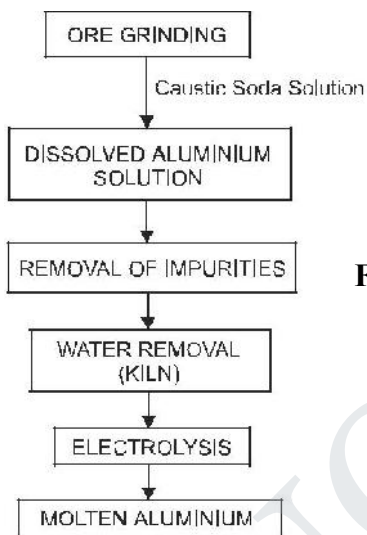

Fig. Flow Diagram for Extraction of Aluminum

Alloys

Aluminum is commonly alloyed with copper silicon, magnesium, or zinc to improve its mechanical properties. Some aluminum alloys also contain one or more of the metals manganese, lead, nickel, chromium, titanium, and beryllium. A large part of the aluminum production is utilized in making light, stiff, corrosion-resistant alloys with these metals. Aluminum alloys may be classed as the cast alloys, which are shaped by casting and wrought alloys, which are worked into different shapes by mechanical operations. Cast alloys are generally binary alloys containing copper or silicon, and sometimes magnesium. Wrought alloys contain copper, magnesium, silicon, and manganese that form precipitation hardening alloys with aluminum. Following are some of the aluminum alloys.

Duralumin contains 3–5% copper, 0.51–1% magnesium and 0–0.07% manganese. 0.3–0.6% iron and 0.3%–0.6% silica are present as impurities. The relative density is 2.80, which is quite low as compared to that of mild steel. However, when rolled and heat treated tensile strength equals that of mild steel. Its yield point is 206.85 N/mm^2 . It is highly resistant to corrosion. Wire and sheets are drawn from duralumin. Duralumin may be fabricated into different structural shapes to be used for construction.

Magnesium is an alloy of aluminum and magnesium (6 per cent). It has got very good mechanical properties and is a little lighter than pure aluminum. It is easy to work, exceptionally strong, and ductile and is widely used as deoxidizers in copper smelting operations.

Aldural When a coating of aluminum is given to duralumin it is known as aldural and has better corrosion resisting properties.

Y-alloy invented during World War II contains 4 per cent copper, 20 per cent nickel and 1.5 per cent magnesium. Toughness and hardness are achieved by heating it to 500°C for six hours and then cooling it down in boiled water. Its relative density is 2.80 and resists corrosion better than duralumin. Y-alloy has good thermal conductivity and can sustain high temperature. It is used for making pistons of I.C. engines, cylinder head, connecting rod and propeller blades.

Aluminium Bronze contains less than 11 per cent of aluminium and is rather inappropriately named. It is highly ductile when aluminium is less than 7.3 per cent. As the aluminium increases, ductility decreases and at 12 per cent the alloy is very brittle. Bronzes containing less than 7.3 per cent aluminium are highly resistant to torsional stress, readily rolled, forged, cold drawn, exhibit toughness under impact and resistance to alternate bending stress.

An input of 1 per cent of manganese into 10 per cent aluminum bronze increases the yield point and ductility without change in strength or endurance under reversal of stress. The modulus of elasticity of aluminium bronze is about $1.03425 \times 10^5 \text{ N/mm}^2$. These are almost incorrodible in sea water and in this respect are superior to Muntz metal or naval brass.

Aluminium bronze is used for pump lines, tubes, springs, screws, rivets, ornamental works, marine engineering castings, motor boat shafting, musical instruments, and as a substitute of mild steel to resist corrosion, grill works, etc.

Light Alloy contains 3 per cent copper and 12 per cent zinc. It is used for castings such as crank and gear housings. **Aluminium-Copper Alloy** contains copper up to 4 per cent. Less liable to burning the alloy produces light castings that are stronger and tougher than that made from aluminium. It is mainly used in automobile industry for casting.

Aluminium-Zinc Alloy contains zinc up to 15 per cent and is used for light casting which can be easily machined or forged into desired form. These are very sensitive to high temperatures in melting and in solid form exhibit low strength and brittleness when heated above 50° C. Alloys containing 15 to 25 per cent zinc are harder, stronger, but less ductile and more difficult to roll or draw. If percentage of zinc is increased above 25 the alloy suffers decrease in strength when excessively worked, either hot or cold. Aluminium zinc alloys have well defined yield points. **Aluminium-Silicon Alloy** Aluminium alloys containing 5 to 15 per cent silicon are important because their excellent casting qualities, including excellent fluidity and freedom from hot-shortness, permit the pouring of thin intricate sections. They also have high resistance to corrosion, are good conductors of heat, and have low thermal expansion

Aluminium composite panel (ACP) also **aluminium composite material, (ACM)** is a type of flat panel that consists of two thin aluminium sheets bonded to a non-aluminium core. ACPs are frequently used for external cladding or facades of buildings, insulation, and signage.^[3]

Aluminium sheets can be coated with polyvinylidene fluoride (PVDF), fluoropolymer resins (FEVE), or polyester paint. Aluminium can be painted in any kind of colour, and ACPs are produced in a wide range of metallic and non-metallic colours as well as patterns that imitate other materials, such as wood or marble. The core is commonly low density polyethylene, or a mix of low density polyethylene and mineral material to exhibit fire retardant properties.

3A Composites (formerly Alcan Composites & Alusuisse) invented aluminium composites in 1964 and commercial production of Alucobond commenced in 1969, followed by Dibond 20 years later.

4.8.1 Applications

Sandwich panels are used in those applications where high structural rigidity and low weight is required. An evident example of use of sandwich panels is aircraft where mechanical performance and weight saving is essential. Other applications include packaging (e.g. fluted polypropylene boards of polypropylene honeycomb boards), transportation and automotive as well as building & construction.

ACP is mainly used for external and internal architectural cladding or partitions, false ceilings, signage, machine coverings, container construction etc. Applications of ACP are not limited to external building cladding, but can also be used in any form of cladding such as partitions, false ceilings etc. ACP is also widely used within the signage industry as an alternative to heavier, more expensive substrates.

Epcot's Spaceship Earth is an example of the use of ACP in architecture. It is a geodesic sphere composed of 11,324 ACP tiles.

ACP has been used as a light-weight but very sturdy material in construction, particularly for transient structures like trade show booths and similar temporary elements. It has recently also been adopted as a backing material for mounting fine art photography, often with an acrylic finish using processes like Diasec or other face-mounting techniques. ACP material has been used in famous structures as Spaceship Earth, VanDusen Botanical Garden, the Leipzig branch of the German National Library.

These structures made optimal use of ACP through its cost, durability and efficiency. Its flexibility, low weight and easy forming and processing allow for innovative design with increased rigidity and durability.

4.8.2 Other names

Many people use **Alucobond** or **sandwich panel** as a generic name (genericized trademark) for aluminum composite panels that are typically 0.3 to 0.5 mm thick aluminum sheets covering a solid polyethylene core with a total thickness of 3 mm or more, or similar panels from any manufacturer.^[9]

A variety of manufacturers sell aluminium composite panels under a wide variety of brand names, including: (in no particular order)

Alucobond from 3A Composites, ALPOLIC from Mitsubishi Plastics, Aluminum wall claddings from Guangzhou Xinghe Aluminum Co, Ltd Reynobond from Alcoa, Envelope 2000 from CitadelAP, Aludecor from HMB Group, Larson from Alucoil, Hylite from 3A Composites, VillaBOND from Villa Bond, Dibond from 3A Composites and Alcan, WILLSTRONG from WILLSTRONG CO. Max-Metal from Grimco, RedBond from aRedBond Composites, Vitrabond from Fairview Architectural, Plascore Board from Plascore, Alupanel and Alupanel XT are manufactured by Multipanel UK in their own UK factory, Etalbond from Elval Colour, AlubondAfrica, Pink Rhino from Pettongtana etc.

Some people use **sandwich panel** for any structural sandwich (sandwich-structured composite) of a core bonded between two cover sheets, no matter what material(s) it is made of, and no matter if the core is solid, foam, flutes, or honeycomb.^[10]

4.8.3 The selective use of ACP

An important aspect to discuss here is the haphazard use of ACP, a trend for which the user is responsible and not the material. One can witness the use of ACP in newly constructed buildings in areas of historic importance without any regard to the built environment of the place thus ruining the architectural, historic and cultural fabric of the place.

It can be argued that ACP is a stylish and sensible innovation, which can prove to be a blessing for commercial as well as decorative purposes. Yet one should be aware of its benefits as well as demerits, and also realize its installation process and features. This

would result in the proper use of the material instead of the haphazard nature of its current introduction into the buildings in the city.

Paint is a liquid surface coating. On drying it forms a thin film (60–150 m) on the painted surface. Paints are classified as oil paints, water paints, cement paints, bituminous paints and special paints such as fire proof paints, luminous paints, chlorinated rubber paints (for protecting objects against acid fumes), etc.

The functions of the paints are: to protect the coated surface against possible stresses—mechanical or chemical; deterioration—physical or environmental; decorate the structure by giving smooth and colourful finish; check penetration of water through R.C.C; check the formation of bacteria and fungus, which are unhygienic and give ugly look to the walls; check the corrosion of the metal structures; check the decay of wood work and to varnish the surface to display it to better advantage.

4.9 Composition

Base The base, usually a metallic oxide, is the principal constituent of the paint. It makes the paint film opaque and possesses binding properties which reduce the shrinkage cracks in the film on drying. Some of the examples of base are white lead, red lead, zinc white, aluminium powder, iron oxide, etc. Their detailed description is given in Table Lead based paints are in general affected by atmosphere and are not recommended for final coats. Zinc white is weather resistant. For inferior works Lithophone (barium sulphate chemically combined with zinc sulphide) is used for inside work. Aluminium powder is used as base for all aluminium paints.

Vehicle Also known as binder, vehicle is an oil to which the base is mixed. It holds the constituents of paint in suspension and helps spread it over the surface to be painted, imparts durability, toughness and water proofness to the paint film and resistance to weathering and gloss to the painted surface and forms the body of the paint. The examples are natural drying oils such as linseed oil, nut oil, poppy oil and tung oil (Table); animal, paint, artificial and synthetic glues in glue paints and air slaking lime and polymer in lime water colours and polymer paints respectively.

The natural drying oils (glycerides of the unsaturated fatty acids) harden in this layers to form strong and elastic surface coats. These are available in oxidized and polymerized varieties. The former being obtained by blowing air through linseed oil heated to about 160°C and by introducing a manganese-lead-cobalt drier the latter is obtained by polymerising linseed oil by heating it to about 275°C and introducing a manganese-lead-cobalt siccative

Table Description of Bases

S.No	Name	Description
1.	White lead	This is a carbonate of lead and forms the base of lead paints. It is dense, permanent and water-proof. It is not suitable for delicate works as lead becomes discoloured when exposed to sulphur vapours. It is most suitable for wood surfaces; Since it does not afford protection against rusting, it is not suitable for iron surfaces.
2.	Red lead	This is an oxide of lead and forms the base of lead paints. It is most suitable for painting iron surfaces and for providing a priming coat to wood surfaces. It solidifies in a short time with linseed oil and hence, it is used as a drier also.
3.	Zinc white	This is an oxide of zinc and forms the base of all zinc paints. It is smooth, transparent and non-poisonous. It is not discoloured when exposed to sulphur vapours. It is less durable and is difficult to work.
4.	Oxide of iron	This is an oxide of iron and forms the base of all iron paints. The tint of paint varies from yellowish brown to black. It mixes easily with the vehicle. It is effective in preventing rusting of iron surfaces and is cheap and durable. It is generally used for priming coat of iron surfaces.
5.	Titanium white	This material possesses intense opacity. It is non-poisonous and provides a thin transparent film. It is used for receiving the coat of an enamel.
6.	Antimony white	This is almost similar to titanium white.
7.	Aluminium powder	This forms the bulk of aluminium paints. It keeps moisture content of wood surfaces practically the same and also prevents cracking and warping of wood. It is generally used for a priming coat to new wood work.
8.	Lithophone	This is a mixture of zinc sulphide and barytes. It is similar in appearance to oxide of zinc. It is cheap and can easily be applied on the surface. However, when exposed to daylight, it changes colour, hence used for interior works only.

Linseed oil is the most widely used vehicle. It contains acid which reacts readily with oxygen and hardens by forming a thin film known as linoxyn. A priming coat of pure linseed oil induces corrosion which is greatly retarded by the presence of pigments. For this reason priming coat should contain little oil. Raw linseed oil has slow drying rate as such pale boiled linseed oil having better drying properties is used. The best results are obtained by using double boiled linseed oil.

Pigments are used to hide the surface imperfections and to impart the desired colour. They protect the paint film by reflecting the destructive ultra violet light, which acts as a catalytic agent for the destructive oxidation of the film. They also improve the impermeability of the paint film and enhance its resistance to weathering, affect the flow characteristics making it possible to paint vertical and uneven surfaces smoothly. Pigments are finely ground mineral, organic substances or metal powders; their size in organic coatings ranges from 0.1 to 5.0 microns in diameter. Their general properties are covering power, colouring capacity, fineness, fire resistance, chemical stability and weather resistance. The fine particles of the pigments have a reinforcing effect on the paint film.

The common pigments are classified as natural and artificial. The former used for preparing limestone and glue paints, putties and coloured building mortars, include ground natural white chalk, mastics, grey graphite, dry yellow ochre (a clay containing over 15 per cent of iron oxide), etc. Artificial mineral pigments, obtained by chemical processing of raw mineral materials, include titanium dioxide, zinc white, lead white ($2\text{PbCO}_3 \cdot \text{Pb}(\text{OH})_2$), lithophone ($\text{BaSO}_4 + \text{ZnS}$), chrome oxide, red lead, gas black soot, etc. metal powders such as aluminium powder, metallic powders, gold dust, etc. synthetic substances of organic origin, possessing high dyeing capacity. Some of the examples of pigments used to produce the desired colours are lamp black and ivory black (Black), Prussian blue, indigo (Blue), chrome yellow, yellow ochre (yellow), burnt umber, burnt sienna (Brown), vermilion, red lead (Red) and copper sulphate (Green).

Solvents are the oils used to thin the paints, increase the spread, and are also known as thinners. They make the paint of workable consistency and evaporate during drying of the film. The common thinning agents used are petroleum, spirit, naphtha and turpentine oil—a mixture of the various terpens, obtained from the steam distillation of the resinous exudations of the pine tree, leaving resin as a by-product. Turpentine is used extensively because of high solvent power, excellent flattening properties and ideal rate of evaporation.

Driers also known as plasticizers, are chemicals added to paint for specific purposes, e.g., as catalyst (accelerate the drying of the vehicle) for the oxidation, Polymerisation and condensation of the vehicle in paint. The quantity of drier is limited to 8 per cent, excess of it affects the elasticity of paint leading to flaking failure. Some of the examples of driers are letharge (oxidized lead, PbO), lead acetate, red lead (Pb_3O_4), manganese dioxide and cobalt, zinc and lead chromate. Red lead is the best for primary coat over steel and metal work; it produces an extremely hard and tough film, almost impervious to air and moisture, adheres firmly to the metal and is extremely effective in protecting steel from corrosion. The cost of zinc and lead chromates is high.

Table Description of Vehicles

S.No.	Name	Description
1.	Linseed oil	This is most common vehicle extracted from flax seeds. Linseed oil prepared from fine full-grown ripe seeds is clear, transparent, pale, sweet to the taste and practically odourless. It is used in the following grades: Raw linseed oil is thin and pale. It requires more time for drying and is used for interior works of delicate nature. This oil is thicker and dark coloured than that of the raw oil. It dries quickly and is prepared by adding some quantity of drier such as litharge or red lead to the raw oil. It is used for exterior surfaces only. This is similar to boiled linseed oil except that it does not possess a dark colour. It is more suitable for painting plastered surfaces. This oil dries very quickly and is suitable for external works. It, however, requires a thinning agent like turpentine. Formerly this oil was prepared by exposing raw linseed oil to sun till it thickened like honey. However, at present, heat treatment is used for this purpose. This oil dries slowly and provides a durable, clear and shining finish.
	(a) Raw linseed oil	
	(b) Boiled linseed oil	
	(c) Pale boiled linseed oil	
	(d) Double boiled linseed Oil	
	(e) Stand oil	
2.	Tung oil	This oil is far superior to linseed oil and is used for preparing paints of superior quality.
3.	Poppy oil	This oil is prepared from poppy seeds. It dries slowly and its colours are long lasting. It is used for making paints of delicate colours.
4.	Nut oil	This oil is extracted from ordinary walnuts. It is nearly colourless and dries rapidly. It does not provide a durable finish and is used for ordinary work.

Adultrants bring down the overall cost, reduce the weight and increase the durability. Adultrants also help to reduce cracking of dry paint and sometimes help to keep the pigment in suspension. Barium sulphate, calcium carbonate, magnesium silicate and silica are but a few examples. The best adultrant is barium sulphate. Silica is used only in the undercoats so as to take the advantage of its roughness in development of bond with the next coat.

4.10 Characteristics Of An Ideal Paint

The requirements are uniform spread as a thin film, high coverage, good workability and durability, sufficient elasticity to remain unaffected by expansion or contraction of the surface to be painted or by weathering action of atmosphere. The paints should also be: impervious to air and water, cheap and economical to form a hard surface.

4.10.1 Preparation Of Paint

The base is ground in a vehicle to the consistency of paste in a stone pestle known as muller. Linseed oil, is intermittently added to the paste in small quantities and the mixture is stirred with a wooden puddle. In case of coloured paints, the pigment is mixed with linseed oil separately and the paste is formed as explained above. Driers are also ground separately in linseed oil. The three pastes so prepared are mixed and a little linseed oil is added further to soften the paste. The mixture is continuously stirred till a consistency of cream is obtained. The mixture is thereafter strained through fine canvas or a sieve. The paint is now ready for use. The paint so prepared can be used by adding oil or a thinner to make it of workable consistency before application.

For commercial manufacturing of paints a four-storey building is used to have gravitational flow of materials. Pigments, oil, thinner, plasticizer, drier, etc. are stored on the fourth floor and are fed by means of chutes in proper proportions, to the grinding mill placed on the third floor and are ground. The thoroughly ground materials are then sent to storage tanks on the second floor. The charge in the tanks is kept in motion by agitation mechanism so that settling of materials does not take place. An additional quantity of vehicle is added here to get the desired composition. The batch is then tested for quality control. The paint material is then strained and sent to first floor, where it is packed in containers. Finally the packed material in containers is sent to the ground floor. A flow diagram of paint manufacture is shown in Fig.

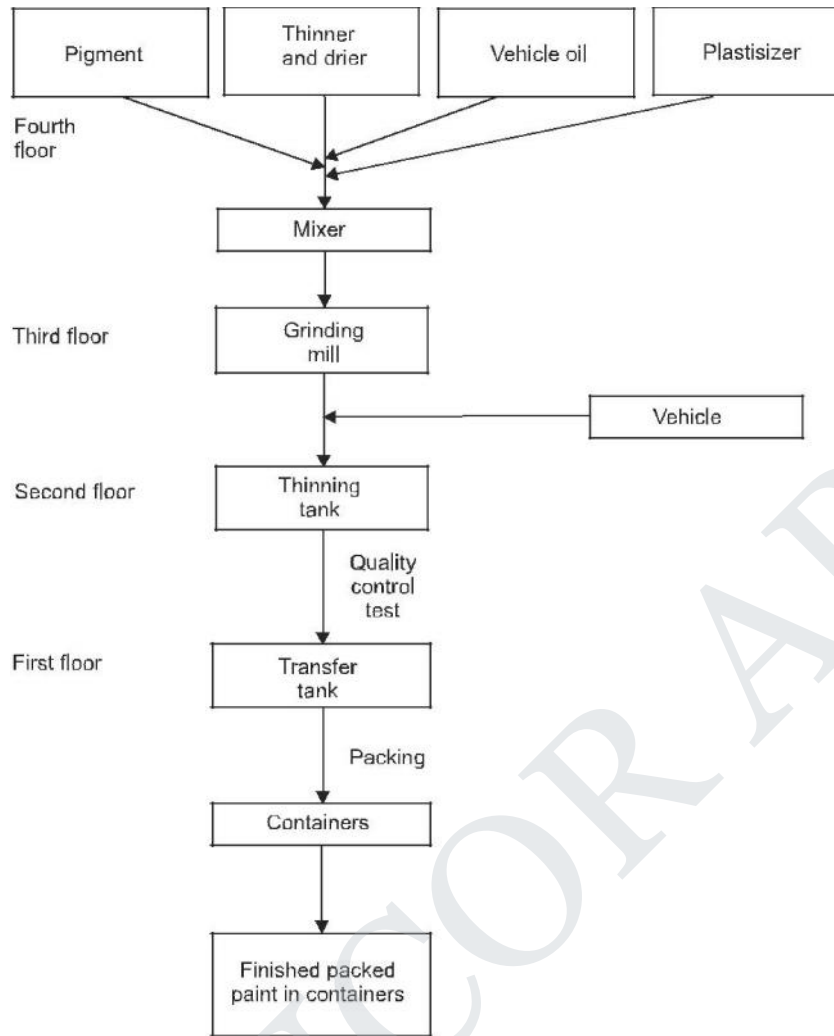

Fig. Flow Diagram of Paint Manufacture

The factors affecting the quality of paint so prepared are quality of ingredients, grinding, intimate mixing and proportioning, straining, packing, etc. Ready mixed paints are also available in the market with different trade names, e.g., Asian, Ducco, Shalimar, Berger Nerolac, etc.

Chapter 5

Modern Materials

Glass – Ceramics – Sealants for joints – Fibre glass reinforced plastic – Clay products – Refractories – Composite materials – Types – Applications of laminar composites – Fibre textiles – Geomembranes and Geotextiles for earth reinforcement.

5.1 Glass

Glass is an amorphous substance having homogeneous texture. It is a hard, brittle, transparent or translucent material. It is the most common material glazed into frames for doors, windows and curtain walls. The most common types used in building construction are sheet, plate, laminated, insulating, tempered, wired and patterned glass. Most ordinary colourless glasses are alkali-lime silicate and alkali-lead silicate with tensile and compressive strengths of about 30–60 N/mm² and 700–1000 N/mm², respectively and modulus of elasticity in the range 0.45×10^5 to 0.8×10^5 N/mm². The strength is very much affected by internal defects, cords and foreign intrusions. The main shortcoming of glass is its brittleness which depends on a number of factors, the chief one being the ratio of the modulus of elasticity of the material to its tensile strength.

5.1.2 Constituents

The raw materials used in manufacturing glass are sand, lime (chalks) and soda or potash which are fused over 1000° C. Oxides of iron, lead and borax are added to modify hardness, brilliance and colour. The functions of the various ingredients are as follows.

Silica is used in the form of pure quartz, crushed sandstone and pulverised flint; should be free from iron contents for best quality glass. Since it melts at very high temperatures (1710° C) carbonates of sodium or potassium are added to lower down the fusing temperature to about 800° C. These also make liquid silica more viscous and workable.

Lime is used in the form of limestone, chalk or pure marble and sometimes marl. The addition of lime makes the glass fluid and suitable for blowing, drawing, rolling, pressing or spinning. It also imparts durability and toughness to glass. Excess of lime makes the molten mass too thin for fabrication.

Soda acts as an accelerator for the fusion of glass and an excess of it is harmful.

Potash renders glass infusible and makes glass fire resistant.

Lead Oxide imparts colour, brightness and shine. When 15–30% of it added to substitute lime it lowers the melting point, imparts good workability, while its transparency is lost with the glass becoming brittle and crystalline.

Cullets are broken glasses added to act as a flux to prevent loss of alkali by volatilisation during the process of forming glass and also to lower the fusion temperature. However, flux may reduce the resistance of glass to chemical attack, render it water-soluble or make it subject to partial or complete devitrification (crystallisation) on cooling. These crystalline areas are extremely weak and brittle. Stabilizers are added to overcome these defects.

Titanic acid, oxides of Nickel and Cobalt are used for chromatic neutralisation.

Note: Iron is not desirable as a constituent. However, when present it imparts a bottle green colour to the glass. To overcome this manganese dioxide known as glass maker’s soap is added which washes the liquid glass and removes the colour.

5.1.3 Manufacture

Glass is manufactured in the following four steps:

Melting The raw materials — lime, soda and sand — separately cleaned, ground, sieved (called ‘Batch’) in definite proportion and mixed with water are fused in a continuous type (tank) furnace or batch-type (pot) furnace. The charge in the first stage melts, forming a bubbly, sticky mass, and as the temperature is raised (1100° C–1200° C) it turns to a more watery liquid and the bubbles rise to the surface. The melting process in case of ordinary soda-glass involves the following series of reactions:

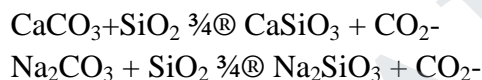

When all the carbon dioxide has escaped out of the molten mass, decolourisers such as MnO₂ or nitre are added to do away with ferrous compounds and carbon. The colouring salts are added at this stage. Heating is continued till the molten mass is free from bubbles and glass balls. As the glass cools (800° C), it is ready to be drawn or floated to its desired thickness and size at the other end of the furnace as shown by a flow diagram in Fig..

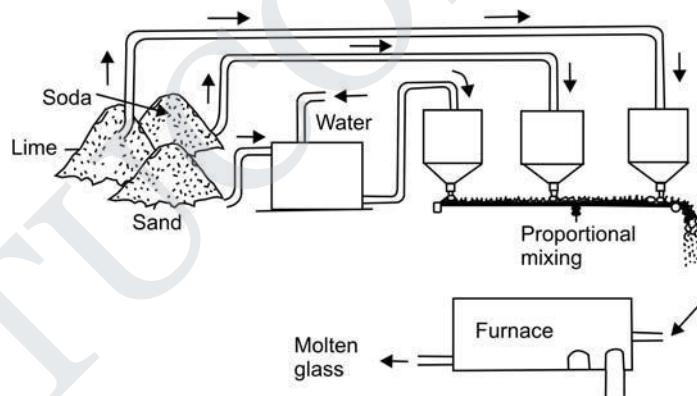

Fig. Glass Manufacturing Process

Forming and Shaping The molten glass can be fabricated to desired shapes by any one of the following methods:

Blowing A 2 m long and 12 mm diameter blow pipe is dipped in the molten glass and taken out. It is held vertically and is vigorously blown by the operator. The sticking molten glass takes the shape of a hollow ball. On cooling it is reheated and the blowing operation repeated a number of times till the desired articles are ready.

Flat Drawing The process of drawing the glass up into a sheet begins when an grille (bait) is lowered into the glass in the kiln. In a short time the liquid molten glass adheres to the bait, and as the bait is slowly lifted it draws a sheet of glass. The bait and the drawn sheet of glass are then drawn through rollers, the bait is cracked off and a continuous sheet of glass is drawn up. This sheet is then slowly cooled in a chamber and annealed for cutting into proper size. A machine for vertical drawing of glass is shown in Fig..

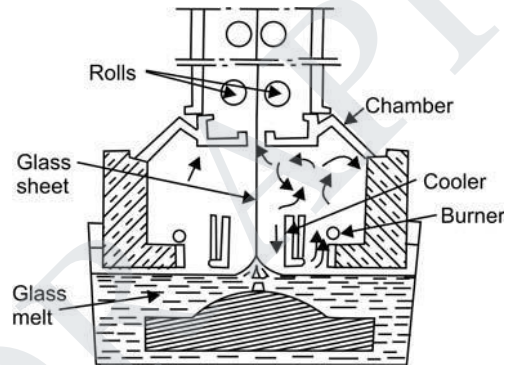

Fig. Machine for Vertical Drawing of Glass

Compression Moulding In this process moulds are used to obtain the articles of desired shapes.

Spinning A machine is used to spin the molten glass. The fibres so produced are very fine and are used for heat and sound insulation.

Annealing Glass articles are allowed to cool under room temperature by passing through different chambers with descending temperature. If cooled rapidly, the glass being bad conductor of heat, the superficial layer cools down first and strain develops in the interior portions, which causes unequal expansion and the articles are likely to crack.

Finishing After annealing the glass articles are cleaned, ground, polished, cut and sand blasted.

5.1.4 Classification

Depending upon the constituents glasses are classified as soda-lime glass, lead glass and boro-silicate glass.

Soda-lime Glass is also known as soda-ash glass, soda glass or soft glass. Soda-lime glass is obtained by fusing a mixture of silica, lime and soda. The quality of this glass can be improved by adding alumina and magnesium oxide and the glass is then called crown glass. This is the most common type of glass used in doors, windows and for making glass-wares such as bottles.

Lead Glass also known as flint glass is obtained by fusing a mixture of silica, lead and potash. It is free from iron impurities and is colourless. Lead glass has high shining appearance and can take polish. It is not affected by temperature. Electric bulbs, optical glasses, cut glass, ornamental glass works and radio valves are some of the articles made from it.

Boro-silicate Glass is obtained by fusing a mixture of silica, borax, lime and felspar. The examples are pyrex glass and heat resisting glass. Boro-silicate glass can withstand high temperatures and is most suitable for making laboratory equipments and cooking utensils.

5.1.5 Commercial Forms

Sheet Glass is used for glazing doors, windows and partitions and is obtained by blowing the molten glass into the shape of a cylinder. The ends of the cylinder so produced are cut away and the cylinder is flattened over a plane tray. It is available in thicknesses of 2, 2.5, 3, 4, 5, 5.5 and 6.5 mm and up to 1750×1100 mm size and is classified as

Type	Uses
Ordinary glazing quality	General engineering purpose
Selected glazing quality	Class works
Special selected quality	Superior quality works such as show cases and cabinets etc.

Plate Glass is used for all engineering purposes and is superior to sheet glass. A plate glass differs from a sheet glass in that it has a parallel, distortion-free surface obtained by grinding or floating process. It is produced by pouring the molten glass on casting tables and levelling it to an uniform thickness. Both the glass surfaces are then ground, smoothed and polished. Glass so produced is clear and contains unblemished true plane surfaces and is available in thicknesses of 3 to 32 mm and sizes up to 2750×900 mm. It is classified as

Type	Uses
Ground glass quality	Showcases, cabinets, counters, shop fronts, etc.
Selected glazing quality	Making mirrors
Special selected quality	High class works, wind screen of vehicles

Tempered Glass is made from plate glass by reheating and sudden cooling and is 3 to 5 times stronger than plate glass. Although not unbreakable, it resists bending stress better than plate glass and, when broken, the pieces are relatively small in size. It is used extensively in sports arenas, sliding doors and curtain walls.

Wired Glass is produced by embedding wire nets 0.46 to 0.56 mm into the centre of sheet glass during casting. The minimum thickness of wired glass is 6 mm. When broken it does not fall into pieces. It has higher melting point than ordinary glass. Wired glass is used for fire resisting doors and windows, for sky lights and roofs. A special example of this is wired-refrax glass which transmits 100 per cent more light than the other glasses.

Obscured Glass is made comparatively opaque to sunlight. Also known as patterned glass. They are classified as frosted, rolled and ribbed.

Frosted glass is produced by subjecting the polished face of the glass to a sand blast which grinds off the surface. It can also be produced by etching on glass by hydrofluoric acid.

Rolled glass has a series of waves of desired pattern on the surface and is also known as figured rolled glass.

Ribbed glass A series of triangular ribs are produced in the glass during casting.

Laminated Glass is made by sandwiching a layer of polyvinyl butyral between two or more layers of plate or sheet glass. It is also known as safety glass. The examples are heat proof glass, sound proof glass and bullet proof glass. Heat and sound proof glasses Two or more glass plates are sandwiched by a tinted plastic inner layer. It provides high resistance to heat and glare. By increasing the thickness of plastic layer the glass can be made more sound resistant.

Bullet proof glass is produced by placing vinyl plastic and glass in several alternate layers and pressing them with outer layers of glass. It is used in banks, jewellery stores and display windows.

Insulating glass is composed of two glass plates into which a layer of 6–13 mm thick dehydrated air is sealed. The round edges are formed by fusing together the two glass plates. These glasses reduce the heat transmission by 30–60 per cent.

Heat absorbing Glass is bluish green in colour and cuts ultra violet rays of sun. The example is calorex. It is used in railway carriages, factories, hospitals, health clubs and kitchens.

Ground Glass In this type of glass one face of plate or sheet glass is made rough by grinding. It is used for maintaining privacy by obstructing vision and at the same time allowing light. The ground glass is used for bedrooms, toilets and for making black boards.

Block Glass is hollow sealed made by fastening together two halves of pressed glass. It is used for making partitions.

Coloured Glass is produced by adding oxides of metals to molten glass:

Types of glasses	Metal oxide
Ruby red glass	Lead glass, 1 per cent of cupric oxide and 1 per cent of magnetic oxide of iron
Ruby rose glass	Gold chloride is used as colouring agent. Brownish red colour is obtained by adding oxide

Blue glass	of iron, bluish red shade is obtained by adding
Yellow glass	2 per cent MnO_2 and 4 per cent nitre (KNO_3).
(a) Uranium glass (greenish yellow)	0.1 per cent of cobalt oxide in ordinary glass.
(b) Selenium glass (orange)	2–3% of alkali uranate.
Green glass (emerald green)	Selenite and a reducing agent or ferric oxide and MnO_2 .
Violet glass (violet)	Oxide of chromium Cr_2O_7 .
Black glass	MnO_2
	Oxide of Co and Mn.

Opal Glass is also known as milk glass. It is produced by adding bone ash, oxide of tin and white arsenic to vitreosil (99.5% silica glass known as clear silica glass). The composition is 10 parts of sand, 4 parts cryolite and 1 part zinc oxide.

Enamel Glass is produced by adding calcined lead and tin oxide to the ordinary glass. The composition is 10 parts sand, 20 per cent lead and tin oxide and 8 parts potash.

Optical Glass contains phosphorus, lead silicate and a little cerium oxide, the latter capable of absorbing ultraviolet light injurious to eyes. They are used for making lenses.

5.2 Ceramic

A **ceramic** is an inorganic, nonmetallic solid prepared by the action of heat and subsequent cooling. Ceramic materials may have a crystalline or partly crystalline structure, or may be amorphous (e.g., a glass). Because most common ceramics are crystalline, the definition of ceramic is often restricted to inorganic crystalline materials, as opposed to the non crystalline glasses, a distinction followed here.

The earliest ceramics made by humans were pottery objects, including 27,000 year old figurines, made from clay, either by itself or mixed with other materials, hardened in fire. Later ceramics were glazed and fired to create a colored, smooth surface. Ceramics now include domestic, industrial and building products and a wide range of ceramic art. In the 20th century, new ceramic materials were developed for use in advanced ceramic engineering; for example, in semiconductors.

5.3 Fibre glass reinforced plastic

Description: FRP is a composite material made of a polymer matrix reinforced with fibers. The polymer is usually an epoxy, vinylester or polyesterthermosetting plastic. FRP is commonly used in the aerospace, automotive, marine, and construction industries.

Application: FRP is manufactured and tested to perform in locations such as: commercial kitchens, public restrooms, hospitals, schools, correctional facilities, restaurants, car washes, meat and dairy facilities, coolers and freezers, supermarkets, clean rooms and laboratories.

5.4 Clay products

Clay products are one of the most important classes of structural materials. The raw materials used in their manufacture are clay blended with quartz, sand, chamatte (refractory clay burned at 1000–1400°C and crushed), slag, sawdust and pulverized coal. Structural clay products or building ceramics* are basically fabricated by moulding, drying and burning a clay mass. Higher the bulk specific gravity, the stronger is the clay product. This rule does not hold good for vitrified products since the specific gravity of clay decreases as vitrification advances.

Bulk specific gravity of clay brick ranges from 1.6 to 2.5.

According to the method of manufacture and structure, bricks, tiles, pipes, terracotta, earthenwares, stonewares, porcelain, and majolica are well recognized and employed in building construction. Clay bricks have pleasing appearance, strength and durability whereas clay tiles used for light-weight partition walls and floors possess high strength and resistance to fire. Clay pipes on account of their durability, strength, lightness and cheapness are successfully used in sewers, drains and conduits.

*** Polycrystalline materials and products formed by baking natural clays and mineral admixtures at a high temperature and also by sintering the oxides of various metals and other high melting-point inorganic substances.**

5.4.1 Clay And Its Classifications

Clay is the most important raw material used for making bricks. It is an earthen mineral mass or fragmentary rock capable of mixing with water and forming a plastic viscous mass which has a property of retaining its shape when moulded and dried. When such masses are heated to redness, they acquire hardness and strength. This is a result of micro-structural changes in clay and as such is a chemical property. Purest clays consist mainly of kaolinite ($2\text{SiO}_2 \cdot \text{Al}_2\text{O}_3 \cdot 2\text{H}_2\text{O}$) with small quantities of minerals such as quartz, mica, feldspar, calcite, magnesite, etc. By their origin, clays are subdivided as residual and transported clays. Residual clays, known as Kaolin or China clay, are formed from the decay of underlying rocks and are used for making pottery. The transported or sedimentary clays result from the action of weathering agencies. These are more disperse, contain impurities, and free from large particles of mother rocks.

On the basis of resistance to high temperatures (more than 1580°C), clays are classified as refractory, high melting and low melting clays. The refractory clays are highly disperse and very plastic. These have high content of alumina and low content of impurities, such as Fe_2O_3 , tending to lower the refractoriness. High melting clays have high refractoriness (1350–1580°C) and contain small amount of impurities such as quartz, feldspar, mica, calcium carbonate and magnesium carbonate. These are used for manufacturing facing bricks, floor tiles, sewer pipes, etc. Low melting clays have refractoriness less than 1350°C and have varying compositions. These are used to manufacture bricks, blocks, tiles, etc.

Admixtures are added to clay to improve its properties, if desired. Highly plastic clays which

require mixing water up to 28 per cent, give high drying and burning shrinkage, call for addition of lean admixtures or non-plastic substances such as quartz sand, chamotte, ash, etc. Items of lower bulk density and high porosity are obtained by addition of admixture that burn out. The examples of burning out admixtures are sawdust, coal fines, pulverized coal. etc. Acid resistance items and facing tiles are manufactured from clay by addition of water-glass or alkalis.

Burning temperature of clay items can be reduced by blending clay with fluxes such as felspar, iron bearing ores, etc. Plasticity of moulding mass may be increased by adding surfactants such as sulphite-sodium vinasse (0.1–0.3%).

5.4.2 Physical Properties Of Clays

Plasticity, tensile strength, texture, shrinkage, porosity, fusibility and colour after burning are the physical properties which are the most important in determining the value of clay. Knowledge of these properties is of more benefit in judging the quality of the raw material than a chemical analysis.

By plasticity is meant the property which wetted clay has of being permanently deformed without cracking. The amount of water required by different clays to produce the most plastic condition varies from 15 to 35 per cent. Although plasticity is the most important physical property of clay, yet there are no methods of measuring it which are entirely satisfactory. The simplest and the most used test is afforded by feeling of the wetted clay with the fingers. Personal equation necessarily plays a large part in such determination.

Since clay ware is subjected to considerable stress in moulding, handling and drying, a high tensile strength is desirable. The test is made by determining the strength of specimens which have been moulded into briquette form and very carefully dried.

The texture of clay is measured by the fineness of its grains. In rough work the per cent passing a No. 100 sieve is determined. No numerical limit to the grain size or desired relation between sizes has been established. Very fine grained clays free from sand are more plastic and shrink more than those containing coarser material.

Knowledge of shrinkage both in drying and in burning is required in order to produce a product of required size. Also the amount of shrinkage forms an index of the degree of burning. The shrinkage in drying is dependent upon pore space within the clay and upon the amount of mixing water. The addition of sand or ground burnt clay lowers shrinkage, increases the porosity and facilitates drying. Fire shrinkage is dependent upon the proportion of volatile elements, upon texture and the way that clay burns.

By porosity of clay is meant the ratio of the volume of pore space to the dry volume. Since porosity affects the proportion of water required to make clay plastic, it will indirectly influence air shrinkage. Large pores allow the water to evaporate more easily and consequently permit a higher rate of drying than do small pores. In as much as the rate at which the clay may be safely dried is of great importance in manufacturing clay products, the effect of porosity on the rate of drying should be considered.

The temperature at which clay fuses is determined by the proportion of fluxes, texture, homogeneity of the material, character of the flame and its mineral constitution. Owing to non-uniformity in composition, parts of the clay body melt at different rates so that the softening period extends over a considerable range both of time and temperature. This period is divided

into incipient vitrification and viscous vitrification.

Experiments roughly indicate that the higher the proportion of fluxes the lower the melting point. Fine textured clays fuse more easily than those of coarser texture and the same mineral composition. The uniformity of the clay mass determines very largely the influence of various elements; the carbonate of lime in large lumps may cause popping when present in small percentages, but when finely ground 15 per cent of it may be allowed in making brick or tile. Lime combined with silicate of alumina (feldspar) forms a desirable flux. Iron in the ferrous form, found in carbonates and in magnetite, fuses more easily than when present as ferric iron. If the kiln atmosphere is insufficiently oxidizing in character during the early stages of burning, the removal of carbon and sulphur will be prevented until the mass has shrunk to such an extent as to prevent their expulsion and the oxidation of iron. When this happens, a product with a discoloured core or swollen body is likely to result.

A determination of the fusibility of a clay is of much importance both in judging of the cost of burning it and in estimating its refractoriness.

5.5 Fire-Clay Or Refractory Clay

Fire-clay is a term, loosely applied, to include those sedimentary or residual clays which vitrify at a very high temperature and which, when so burnt, possess great resistance to heat.

These are pure hydrated silicates of alumina and contain a large proportion of silica 55–75%, alumina 20–35%, iron oxide 2–5% with about 1 per cent of lime, magnesia and alkalis. The greater the percentage of alumina, the more refractory the clay will be. Fire clays are capable of resisting very high temperatures up to 1700°C without melting or softening and resist spalling. The presence of a small percentage of lime and magnesia and alkalis help to melt the clay particles more firmly, whereas a large percentage of lime and magnesia tend to melt the clay at low temperatures. Iron oxide or other alkalis reduce refractory qualities of fire clay. The fire clay is used for manufacturing fire bricks used in furnace linings, hollow tiles, and crucibles.

5.5.1 Application Of Clay Products

Universal availability of raw materials, comparative simplicity of manufacture and excellent durability of ceramic materials have put them in the forefront among other constructional materials. The high strength and durability of clay products underlie their wide use in the various elements of buildings, such as walls, wall and floor facing materials, lining materials for chemical industry apparatus, chimney, light porous aggregates for roofing, and sewer pipes. The various applications of clay products in the building industry are as follows.

1. Wall materials. The examples are common clay brick, perforated clay brick, porous and perforated stiff-mud brick, hollow clay dry-press brick. Perforated plastic moulded ceramic stones and light weight building brick. Clay brick accounts for half of the total output of wall materials. Structural properties of hollow clay products and low heat losses through air-filled voids (particularly at subzero temperatures) provide great possibilities for reducing the thickness and the weight of exterior walls. Ceramic facing tiles remain the chief finishing material for sanitary and many other purposes and are still in great use for external facing of buildings.
2. Brick for special purposes. The example are curved clay brick, stones for sewage

installations (underground sewer pipes) brick for road surface (clinker).

3. Hollow clay products for floors. The examples are stones for close-ribbed floors (prefabricated or monolithic), stones for reinforced ceramic beams, sub flooring stones (fillers between beams).
4. Facade decoration. The examples are glazed or non-glazed varieties subdivided in to facing brick and ceramic stones, floor ceramics, small-size ceramic tiles, ceramic plates for facades and window-sill drip stones.
5. Clay products for interior decoration. The examples are tiles for facing walls, built-in parts, large floor tiles and mosaic floor tiles.
6. Roof materials. The examples are common clay roof tiles for covering slopes of roofs, ridge tiles for covering ridges and ribs, valley tiles for covering valleys, end tiles ("halves" and "jambs") for closing row of tiles, special tiles.
7. Acid-resistant lining items. The examples are common acid-resistant brick, acid-resistant and heat-and-acid-resistant ceramic shaped tiles for special purposes, ceramic acid-resistant pipes and companion shapes.
8. Sanitary clay items. Sanitary ware items are manufactured mainly from white-burning refractory clay, kaolins, quartz and feldspar. There are three groups of sanitary ceramics: faience, semi-porcelain and porcelain, which differ in degree of caking and, as a consequence, in porosity. Items from faience have a porous shell, and items from porcelain, a solid shell, while those from semi-porcelain are of intermediate densities. The various degrees of caking of faience, porcelain and semi-porcelain, made of the same raw materials, are due to the latter's different proportions in the working mass.

Solid faience is used mainly to manufacture toilet bowls, wash basins, toilet tanks and bath tubs. Items are glazed, since unglazed faience is water permeable. Semi-porcelain items feature excellent hygienic and mechanical properties being intermediate between those of faience and porcelain. Porcelain outer shell is impervious to water and gases and possesses high mechanical strength and resistance to heat and chemical agent. Porcelain is used to manufacture insulators for power transmission lines, chemical laboratory vessels, etc.

9. Aggregate for concrete. Creamiste (manufactured from low-heat clay), a light weight porous material forms excellent aggregate for light weight concrete.

5.6 Composite materials

Composite materials (also called **composition materials** or shortened to **composites**) are materials made from two or more constituent materials with significantly different physical or chemical properties, that when combined, produce a material with characteristics different from the individual components. The individual components remain separate and distinct within the finished structure. The new material may be preferred for many reasons: common examples include materials which are stronger, lighter or less expensive when compared to traditional materials.

Typical engineered composite materials include:

- Composite building materials such as cements, concrete

- Reinforced plastics such as fiber-reinforced polymer
- Metal Composites
- Ceramic Composites (composite ceramic and metal matrices)

Composite materials are generally used for buildings, bridges and structures such as boat hulls, swimming pool panels, race car bodies, shower stalls, bathtubs, storage tanks, imitation granite and cultured marble sinks and counter tops. The most advanced examples perform routinely on spacecraft in demanding environments.

5.6.1 Types of Composites

- Composite materials are usually classified by the type of reinforcement they use. This reinforcement is embedded into a matrix that holds it together. The reinforcement is used to strengthen the composite. For example, in a mud brick, the matrix is the mud and the reinforcement is the straw. Common composite types include random-fiber or short-fiber reinforcement, continuous-fiber or long-fiber reinforcement, particulate reinforcement, flake reinforcement, and filler reinforcement.

Mud Building Bricks

- Mud building bricks are examples of a composite material invented by ancient humans. A brick formed only with mud is sturdy and resistant to compression, but it has little flexibility, and it can break if bent. Straw has excellent tensile strength, meaning that it resists stretching. By combining both straw with mud, ancient humans were able to create composite bricks that could remain flexible while supporting weight and resisting compression.

Concrete and Reinforced Concrete

- Concrete is a composite material made of cement, sand, stones and water. A chemical reaction that occurs when you combine these materials makes concrete stronger than any one of its components. Concrete is commonly used in building and road construction. When you add reinforced steel rods to the concrete, you create another composite with greater strength and flexibility called reinforced concrete.

Fiberglass

- Fiberglass is made of tiny glass shards held together by resin and other components. In the automotive industry, fiberglass is important for making body kits. The body shell for a car is made up of different layers of fiberglass, such as a gel-coat layer, tissue layer, matting and cloth. The final product is a complete, waterproof, lightweight and strong body kit. Fiberglass can also be a less expensive alternative to other materials.

- Composites can be easily found in nature. Wood is an example of a composite because cellulose fibers are held together by a substance called lignin. These fibers can be found in cotton and thread, but it's the bonding power of lignin in wood that makes it much tougher. Certain types of large rocks can also be regarded as natural composites when they are composed of a variety of smaller rocks and minerals

5.7 Applications of laminar composites

Laminates - Laminates are layers of materials joined by an organic adhesive.

- Cladding - A laminar composite produced when a corrosion-resistant or high-hardness layer of a laminar composite formed onto a less expensive or higher-strength backing.
- Bimetallic - A laminar composite material produced by joining two strips of metal with different thermal expansion coefficients, making the material sensitive to temperature changes.

5.8 Fibre textiles

Textile Fibers Are Special Many fibrous materials are not suitable to make into fabrics, e.g., corn silk or wood slivers. Textile fibers must have certain properties: flexible, thin (but not too thin), long (enough), cohesive, and strong(enough). Textile fibers must be flexible. Wood fibers (unless processed, as into pulp) do not bend easily—you can-not make fabrics from slivers! Textile fibers are also very thin—long in relation to diameter. To be mechanically spun into yarn—drawn out and twisted—staple fibers must have sufficient length, strength, and cohesiveness (fiber-to-fiber friction). Many seed fibers are too short, weak, and slippery to spin into yarn; kapok, for instance, can be used only for stuffing. Of course, for a fiber to be used a great deal, there must be a reasonable supply and price

5.9 Reinforced Earth

The Primary purpose of reinforcing a soil mass is to improve its stability, increasing its bearing capacity and reduce Settlements and Lateral deformations.

Reinforcing materials: stainless steel, aluminum, fiberglass to nylon, polyester, polyamides, and other synthetics in the form of strips.

Geosynthetics, geotextiles, geogrids and geocomposites.

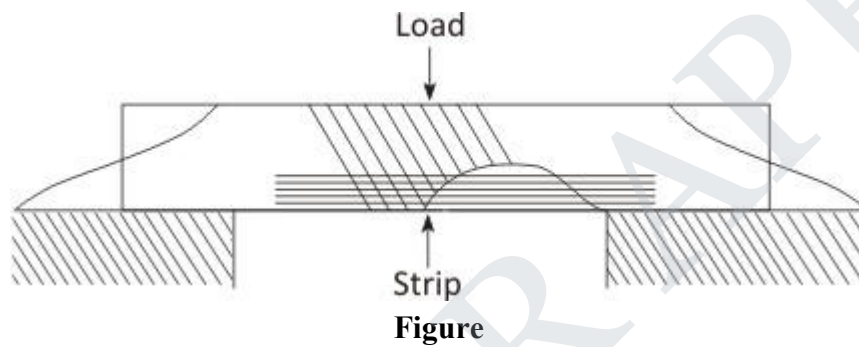
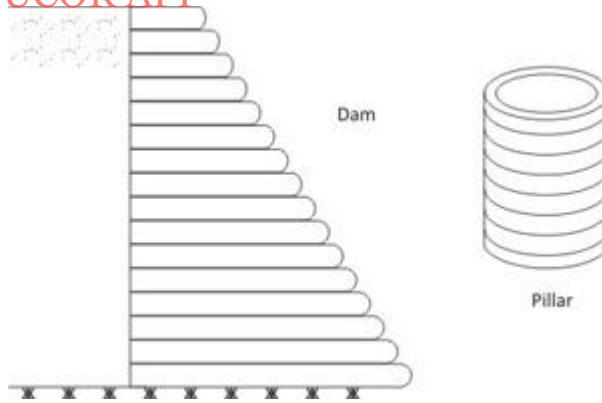

Basic Functions

- Drainage
- Filtration
- Separation
- Reinforcement

Drainage:

Collecting and redirecting seepage water within a soil mass or adjacent to retaining walls culverts and tunnel linings .

Ex - Non-woven fabrics or composites have sufficient inflow capacity to fulfill this function.

Geotextiles acts as a filter if it allows seepage from a water bearing layer while preventing most soil particles from being carried away by the water flow.

Separation

It is achieved if the fabric prevents mixing of adjacent dissimilar soils which may occur

during construction or may be caused by repeated external loading of a soil layer system Most fabrics can act as separators provided they have adequate strength.

Reinforcement

Means the inclusion of the fabric to provide tensile strength, redistribution of stresses and / or confinement, thereby increasing the stability of a soil mass, reducing earth pressures, or decreasing deformation or susceptibility to cracking.

Fabrics are used to provide containment if they are used to form soil or concrete filled bags, tubes, or mattresses. Fabrics are used to act as a tensioned membrane if it supports loads across a gap or plastic zone of soft soil Fabrics may be required to provide cushioning against localized stresses which may cause puncturing or abrasion

If placed on the surface of a slope the geotextile may prevent erosion and dispersion of soil due to wind, surface runoff or wave action.

The function of fabrics in major area of application			
Application	Major functions in order of priority	Special Consideration	Most important properties
Primary roads and rail roads	Separation, drainage, Reinforcement	Repeated loading	Pore size ,permeability strength ,elongation .
Retaining walls , Embankment,and foundations	Reinforcement Separation	Creep	Strength Soil fabric friction
Unpaved roads	Reinforcement Separation	Repeated loading	Strength Elongation
Erosion protection Seepage control	Filtration Drainage Reinforcement	Rapid change in water level	Pore size Permeability strength abrasion
Soil drainage	Drainage Filtration	Clogging	Pore size