

CONTROL SYSTEMS

Questions and Answers

PART-A

Unit - I Systems Components And Their Representation

1. What is control system?

A system consists of a number of components connected together to perform a specific function. In a system when the output quantity is controlled by varying the input quantity then the system is called control system.

2. What are the two major types of control system?

The two major types of control system are open loop and closed loop system.

3. Define open loop control system.

The control system in which the output quantity has no effect upon the input quantity are called open loop control system. This means that the output is not feedback to the input for correction.

4. Define closed loop control system.

The control system in which the output has an effect upon the input quantity so as to maintain the desired output value are called closed loop control system.

5. What are the components of feedback control system?

The components of feedback control system are plant, feedback path elements, error detector and controller.

6. Define transfer function.

The T.F of a system is defined as the ratio of the Laplace transform of output to Laplace transform of input with zero initial conditions.

7. What are the basic elements used for modeling mechanical translational system?

Mass, spring and dashpot.

8. What are the basic elements used for modeling mechanical rotational system?

Moment of inertia J , dashpot with rotational frictional coefficient B and torsion spring with

stiffness K

9. Name two types of electrical analogs for mechanical system.

The two types of analogies for the mechanical system are force voltage and force current analogy.

10. What is Block Diagram?

A Block Diagram of a system is a pictorial representation of the functions performed by each component of the system and shows the flow of signals. The basic elements of block diagram are blocks, branch point and summing point.

11. What is the basis for framing the rules of block diagram reduction technique?

The rules for block diagram reduction technique are framed such that any modification made on the diagram does not alter the input output relation.

12. What is a signal flow graph?

A signal flow graph is a diagram that represents a set of simultaneous algebraic equations. By taking L.T the time domain differential equations governing a control system can be transferred to a set of algebraic equations in s-domain.

13. What is transmittance?

The transmittance is the gain acquired by the signal when it travels from one node to another node in signal flow graph.

14. What is sink and source?

Source is the input node in the signal flow graph and it has only outgoing branches.

Sink is a output node in the signal flow graph and it has only incoming branches.

15. Define non touching loop.

The loops are said to be non touching if they do not have common nodes.

16. Write Masons Gain formula.

Masons Gain formula states that the overall gain of the system is $T = \frac{1}{\Delta} \sum P_k$

k-No.of forward paths in the signal flow graph.

P_k- Forward path gain of kth forward path

$\Delta k = 1 - [\text{sum of individual loop gains}] + [\text{sum of gain products of all possible combinations of two non touching loops}] - [\text{sum of gain products of all possible combinations of three non touching loops}] + \dots$

k - for that part of the graph which is not touching kth forward path.

17. Write the analogous electrical elements in force voltage analogy for the elements of mechanical translational system.

Force-voltage e

Velocity v-current i

Displacement x-charge q

Frictional coeff B-Resistance R

Mass M- Inductance L

Stiffness K-Inverse of capacitance 1/C

18. Write the analogous electrical elements in force current analogy for the Elements of mechanical translational system.

Force-current i

Velocity v-voltage v

Displacement x-flux

Frictional coefficient B-conductance 1/R

Mass M- capacitance C

Stiffness K-Inverse of inductance 1/L

19. Write the force balance equation of an ideal mass element.

$$F = M \frac{d^2x}{dt^2}$$

20. Write the force balance equation of ideal dashpot element.

$$F = B \frac{dx}{dt}$$

21. Write the force balance equation of ideal spring element.

$$F = Kx$$

22. What is servomechanism?

The servomechanism is a feedback control system in which the output is mechanical position (or time derivatives of position velocity and acceleration)

23. Why is negative feedback invariably preferred in closed loop system?

The negative feedback results in better stability in steady state and rejects any disturbance signals.

Unit - II Time Response Analysis

1. What is transient response?

The transient response is the response of the system when the system changes from one state to another.

2. What is steady state response?

The steady state response is the response of the system when it approaches infinity.

3. What is an order of a system?

The order of a system is the order of the differential equation governing the system. The order of the system can be obtained from the transfer function of the given system.

4. Define Damping ratio.

Damping ratio is defined as the ratio of actual damping to critical damping.

5. List the time domain specifications.

The time domain specifications are

i. Delay time

ii. Rise time

iii. Peak time

iv. Peak overshoot

6. Define Delay time.

The time taken for response to reach 50% of final value for the very first time is delay time.

7. Define Rise time.

The time taken for response to raise from 0% to 100% for the very first time is rise time.

8. Define peak time.

The time taken for the response to reach the peak value for the first time is peak time.

9. Define peak overshoot.

Peak overshoot is defined as the ratio of maximum peak value measured from the maximum value to final value.

10. Define Settling time.

Settling time is defined as the time taken by the response to reach and stay within specified error.

11. What is the need for a controller?

The controller is provided to modify the error signal for better control action.

12. What are the different types of controllers?

i. Proportional controller

ii. PI controller

iii. PD controller

iv. PID controller

13. What is Proportional controller?

It is a device that produces a control signal which is proportional to the input error signal.

14. What is PI controller?

It is a device that produces a control signal consisting of two terms - one proportional to error signal and the other proportional to the integral of error signal.

15. What is PD controller?

PD controller is a proportional plus derivative controller which produces an output signal consisting of two terms - one proportional to error signal and other proportional to the derivative of the signal.

16. What is the significance of integral controller and derivative controller in a PID controller?

i. The Proportional controller stabilizes the gain but produces a steady state error.

ii. The Integral control reduces or eliminates the steady state error.

17. Why derivative controller is not used in control systems?

The derivative controller produces a control action based on the rate of change of error signal and it does not produce corrective measures for any constant error.

18. Define Steady state error.

The steady state error is defined as the value of error as time tends to infinity.

19. What is the drawback of static coefficients?

The main drawback of static coefficient is that it does not show the variation of error with time and input should be standard input.

20. What is step signal?

The step signal is a signal whose value changes from zero to A at $t=0$ and remains constant at A for $t>0$.

21. What is ramp signal?

The ramp signal is a signal whose value increases linearly with time from an initial value of zero at $t=0$. The ramp signal resembles a constant velocity.

22. What is a parabolic signal?

The parabolic signal is a signal whose value varies as a square of time from an initial value of zero at $t=0$. This parabolic signal represents constant acceleration input to the signal.

23. What are the three constants associated with a steady state error?

- i. Positional error constant
- ii. Velocity error constant
- iii. Acceleration error constant

24. What are the main advantages of generalized error coefficients?

- i. Steady state is function of time.
- ii. Steady state can be determined from any type of input.

25. What are the effects of adding a zero to a system?

Adding a zero to a system results in pronounced early peak to system response thereby the peak overshoot increases appreciably.

26. State-Magnitude criterion.

The magnitude criterion states that $s=s_a$ will be a point on root locus if for that value of s ,

$$|D(s)| = |G(s)H(s)| = 1$$

27. What is a dominant pole?

The dominant pole is a pair of complex conjugate pair which decides the transient response of the system.

28. What is stepper motor?

A stepper motor is a device which transforms electrical pulses into equal increments of rotary shaft motion called steps.

29. What is servomotor?

The motors used in automatic control systems or in servomechanism are called servomotors.

They are used to convert electrical signal into angular motion.

30. Name the test signals used in control system.

The commonly used test input signals in control system are impulse step ramp acceleration and sinusoidal signals.

31. What is Synchros?

A Synchros is a device used to convert an angular motion to an electrical signal or vice versa.

32. What is steady state error?

The steady state error is the value of error signal $e(t)$ when t tends to infinity.

33. What are static error constants?

The K_p , K_v and K_a are called static error constants.

34. What is the disadvantage in proportional controller?

The disadvantage in proportional controller is that it produces a constant steady state error.

35. What is the effect of PD controller on system performance?

The effect of PD controller is to increase the damping ratio of the system and so the peak overshoot is reduced.

36. Why derivative controller is not used in control system?

The derivative controller produces a control action based on rate of change of error signal and it does not produce corrective measures for any constant error. Hence derivative controller is not used in control system.

37. What is the effect of PI controller on the system performance?

The PI controller increases the order of the system by one, which results in reducing the steady state error. But the system becomes less stable than the original system.

Unit - III Frequency Response And System Analysis

1. What is frequency response?

A frequency response is the steady state response of a system when the input to the system is a sinusoidal signal.

2. List out the different frequency domain specifications.

The frequency domain specifications are

- i. Resonant peak.
- ii. Resonant frequency.

3. Define Resonant Peak (Δ_r)

The maximum value of the magnitude of closed loop transfer function is called Resonant Peak.

4. Define Resonant frequency (Δ_f)

The frequency at which resonant peak occurs is called resonant frequency.

5. What is Bandwidth?

The Bandwidth is the range of frequencies for which the system gain is more than 3 dB. The bandwidth is a measure of the ability of a feedback system to reproduce the input signal noise rejection characteristics and rise time.

6. Define Cut off rate.

The slope of the log-magnitude curve near the cut-off is called cut-off rate. The cut off rate indicates the ability to distinguish the signal from noise.

7. Define Gain Margin.

The Gain Margin, k_g is defined as the reciprocal of the magnitude of the open loop transfer function at phase cross over frequency.

8. Define Gain margin formula.

Gain margin $k_g = 1 / \Delta G(j\Delta_{pc})\Delta$.

9. Define Phase cross over.

The frequency at which, the phase of open loop transfer functions is called phase cross over frequency Δ_{pc} .

10. What is Phase margin?

The Phase margin is the amount of phase lag at the gain cross over frequency required to bring system to the verge of instability.

11. Define Gain cross over.

The Gain cross over frequency Δ_{gc} is the frequency at which the magnitude of the open loop transfer function is unity.

12. What is Bode plot?

The Bode plot is the frequency response plot of the transfer function of a system. A Bode plot consists of two graphs. One is the plot of magnitude of sinusoidal transfer function versus $\log \Delta$. The other is a plot of the phase angle of a sinusoidal function versus $\log \Delta$.

13. 13. What are the main advantages of Bode plot?

The main advantages are:

- i) Multiplication of magnitude can be into addition.
- ii) A simple method for sketching an approximate log curve is available.
- iii) It is based on asymptotic approximation. Such approximation is sufficient if rough information on the frequency response characteristic is needed.
- iv) The phase angle curves can be easily drawn if a template for the phase angle curve of $1+j\Delta$ is available.

14. Define Corner frequency.

The frequency at which the two asymptotic meet in a magnitude plot is called Corner

frequency.

15. Define Phase lag and phase lead.

A negative phase angle is called phase lag. A positive phase angle is called phase lead.

16. What are M circles?

The magnitude of closed loop transfer function with unit feedback can be shown for every value of M. These circles are called M circles.

17. What is Nichols chart?

The chart consisting of M & N loci in the log magnitude versus phase diagram is called Nichols chart.

18. What are two contours of Nichols chart?

Nichols chart of M and N contours, superimposed on ordinary graph. The M contours are the magnitude of closed loop system in decibels and the N contours are the phase angle locus of closed loop system.

19. How is the Resonant Peak (M_r), resonant frequency (ω_r), and band width determined from Nichols chart?

- i) The resonant peak is given by the value of M -contour which is tangent to $G(j\omega)$ locus.
- ii) The resonant frequency is given by the frequency of $G(j\omega)$ at the tangency point.
- iii) The bandwidth is given by frequency corresponding to the intersection point of $G(j\omega)$ and -3dB M-contour.

20. What are the advantages of Nichols chart?

The advantages are:

- i) It is used to find the closed loop frequency response from open loop frequency response.
- ii) Frequency domain specifications can be determined from Nichols chart.
- iii) The gain of the system can be adjusted to satisfy the given specification.

21. What are the two types of compensation?

- i. Cascade or series compensation
- ii. Feedback compensation or parallel compensation.

22. What are the three types of compensators?

- i. Lag compensator
- ii. Lead compensator
- iii. Lag-Lead compensator.

23. What are the uses of lead compensator?

- i. Speeds up the transient response
- ii. Increases the margin of stability of a system
- iii. Increases the system error constant to a limited extent.

24. What is the use of lag compensator?

Improve the steady state behavior of a system, while nearly preserving its transient response.

25. When lag lead compensator is required?

The lag lead compensator is required when both the transient and steady state response of a system has to be improved.

26. What is a compensator?

A device inserted into the system for the purpose of satisfying the specifications is called as a compensator.

Unit - IV Concepts of Stability Analysis

1. What is Nyquist contour?

The contour that encloses entire right half of S plane is called Nyquist contour.

2. State Nyquist stability criterion.

If the Nyquist plot of the open loop transfer function $G(s)$ corresponding to the Nyquist control in the S-plane encircles the critical point $-1+j0$ in the counter clockwise direction as many times as the number of right half S-plane poles of $G(s)$, the closed loop system is stable.

3. Define Relative stability.

Relative stability is the degree of closeness of the system, it is an indication of strength or degree of stability.

4. What are the two segments of Nyquist contour?

i. A finite line segment C1 along the imaginary axis.

ii. An arc C2 of infinite radius.

5. What are root loci?

The path taken by the roots of the open loop transfer function when the loop gain is varied from 0 to ∞ are called root loci.

6. What is a dominant pole?

The dominant pole is a complex conjugate pair which decides the transient response of the system.

7. What are the main significances of root locus?

i. The main root locus technique is used for stability analysis.

ii. Using root locus technique the range of values of K, for a system can be determined.

8. What are the effects of adding a zero to a system?

Adding a zero to a system increases peak overshoot appreciably.

9. Define stability.

A linear relaxed system is said to have BIBO stability if every bounded input results in a bounded output.

10. What will be the nature of impulse response when the roots of characteristic equation are lying on imaginary axis?

If the root of characteristic equation lies on imaginary axis the nature of impulse response is oscillatory.

11. What is the relationship between Stability and coefficient of characteristic polynomial?

If the coefficient of characteristic polynomial are negative or zero, then some of the roots lie on the negative half of the S-plane. Hence the system is unstable. If the coefficients of the characteristic polynomial are positive and if no coefficient is zero then there is a possibility of the system to be stable provided all the roots are lying on the left half of the S-plane.

12. What is Routh stability criterion?

Routh criterion states that the necessary and sufficient condition for stability is that all of the

elements in the first column of the routh array is positive. If this condition is not met, the system is unstable and the number of sign changes in the elements of the first column of routh array corresponds to the number of roots of characteristic equation in the right half of the S-plane.

13. What is limitedly stable system?

For a bounded input signal if the output has constant amplitude oscillations, then the system may be stable or unstable under some limited constraints such a system is called limitedly stable system.

14. In Routh array what conclusion you can make when there is a row of all zeros?

All zero rows in the routh array indicate the existence of an even polynomial as a factor of the given characteristic equation. The even polynomial may have roots on imaginary axis.

15. What is a principle of argument?

The principles of arguments states that let $F(S)$ are analytic function and if an arbitrary closed contour in a clockwise direction is chosen in the S-plane so that $F(S)$ is analytic at every point of the contour. Then the corresponding $F(S)$ plane contour mapped in the $F(S)$ plane will encircle the origin N times in the anti clockwise direction, where N is the difference between number of poles and zeros of $F(S)$ that are encircled by the chosen closed contour in the Splane.

16. What are the main significances of root locus?

- i. The root locus technique is used for stability analysis.
- ii. Using root locus technique the range of values of K , for as stable system can be determined.

17. What are break away and break in points?

At break away point the root locus breaks from the real axis to enter into the complex plane.

At break in point the root locus enters the real axis from the complex plane. To find the break away or break in points, form a equation for K from the characteristic equation and differentiate the equation of K with respect to s . Then find the roots of the equation $dK/ds =$

0. The roots of $dK/dS = 0$ are break away or break in points provided for this value of root the gain K should be positive and real.

18. What are asymptotes? How will you find angle of asymptotes?

Asymptotes are the straight lines which are parallel to root locus going to infinity and meet the root locus at infinity.

Angles of asymptotes = $\pm 180^\circ(2q + 1)/(n-m)$ $q = 0, 1, 2, \dots, (n-m)$

n -number of poles.

m -number of zeros.

19. What is centroid?

The meeting point of the asymptotes with the real axis is called centroid. The centroid is given by

Centroid = $(\text{sum of poles} - \text{sum of zeros}) / (n-m)$

n -number of poles.

m -number of zeros.

20. What is magnitude criterion?

The magnitude criterion states that $s=s_a$ will be a point on root locus if for that value of S , magnitude of $G(S)H(S)$ is equal to 1.

$|G(S)H(S)| = K(\text{product of length of vectors from open loop zeros to the point } s=s_a) / (\text{product of length of vectors from open loop poles to the point } s=s_a) = 1.$

21. What is angle criterion?

The angle criterion states that $s=s_a$ will be the point on the root locus if for that value of S the argument or phase of $G(S)H(S)$ is equal to an odd multiple of 180° .

$(\text{Sum of the angles of vectors from zeros to the point } s=s_a) - (\text{Sum of the angles of vectors from poles to the point } s=s_a) = \pm 180^\circ(2q + 1)$

22. How will you find the root locus on real axis?

To find the root loci on real axis, choose the test point on real axis. If the total number of poles and zeros on the real axis to the right of this test point is odd number then the test point

lie on the root locus. If it is even then the test point does not lie on the root locus.

23. What is characteristic equation?

The denominator polynomial of $C(S)/R(S)$ is the characteristic equation of the system.

24. How the roots of characteristic are related to stability?

If the root of characteristic equation has positive real part then the impulse response of the system is not bounded. Hence the system will be unstable. If the root has negative real parts then the impulse response is bounded. Hence the system will be stable.

25. What is the necessary condition for stability?

The necessary condition for stability is that all the coefficients of the characteristic polynomial be positive. The necessary and sufficient condition for stability is that all of the elements in the first column of the routh array should be positive.

26. What are the requirements for BIBO Stability?

The requirement of the BIBO stability is that the absolute integral of the impulse response of the system should take only the finite value.

27. What is auxiliary polynomial?

In the construction of routh array a row of all zero indicates the existence of an even polynomial as a factor of given characteristic equation. In an even polynomial the exponents of S are even integers or zero only. This even polynomial factor is called auxiliary polynomial. The coefficients of auxiliary polynomial are given by the elements of the row just above the row of all zeros.

Unit - V Control System Analysis Using State Variable Methods

1. State sampling theorem.

A continuous time signal can be completely represented in its samples and recovered back if the sampling frequency $F_s \geq 2F_{max}$ where F_s is the sampling frequency and F_{max} is the maximum frequency present in the signal.

2. What is periodic sampling?

Sampling of a signal at uniform equal intervals is called periodic sampling.

3. What are hold circuits & explain it.

The function of the hold circuit is to reconstruct the signal which is applied as input to the sampler. The simplest holding device holds the signal between two consecutive instants at its preceded value till next sampling instant is reached.

4. What are the problems encountered in a practical hold circuits?

Hold mode may drop occur, nonlinear variation during sampling aperture, error in the periodicity of sampling.

5. What are the advantages of state space analysis?

It can be applied to non-linear as well as time varying systems. Any type of input can be considered for designing the system. It can be conveniently applied to multiple input multiple output systems. The state variables selected need not necessarily be the physical quantities of the system.

6. What are phase variables?

The phase variables are defined as the state variables which are obtained from one of the system variables and its derivatives.

7. Define state variable.

The state of a dynamical system is a minimal set of variables (known as state variables) such that the knowledge of these variables at $t-t_0$ together with the knowledge of the inputs for $t > t_0$, completely determines the behavior of the system for $t > t_0$.

8. Write the general form of state variable matrix.

The most general state-space representation of a linear system with m inputs, p outputs and n state variables is written in the following form:

$$\dot{X} = AX + BU$$

$$Y = CX + DU$$

Where X = state vector of order $n \times 1$.

U = input vector of order $n \times 1$.

A = System matrix of order $n \times n$.

B = Input matrix of order $n \times m$

C = output matrix of order $p \times n$

D = transmission matrix of order $p \times m$.

9. Write the relationship between z-domain and s-domain.

All the poles lying in the left half of the S-plane, the system is stable in S-domain.

Corresponding in Z-domain all poles lie within the unit circle.

10. What are the methods available for the stability analysis of sampled data control system?

The following three methods are available for the stability analysis of sampled data control system

1. Jury's stability test.
2. Bilinear transformation.
3. Root locus technique.

11. What is the necessary condition to be satisfied for design using state feedback?

The state feedback design requires arbitrary pole placements to achieve the desired performance. The necessary and sufficient condition to be satisfied for arbitrary pole placement is that the system is completely state controllable.

12. What is controllability?

A system is said to be completely state controllable if it is possible to transfer the system state from any initial state $X(t_0)$ at any other desired state $X(t)$, in specified finite time by a control vector $U(t)$.

13. What is observability?

A system is said to be completely observable if every state $X(t)$ can be completely identified by measurements of the output $Y(t)$ over a finite time interval.

14. Write the properties of state transition matrix.

The following are the properties of state transition matrix

$$\Phi(0) = e^{A \cdot 0} = I \text{ (unit matrix).}$$

$$\Phi(t) = e^{At} = (e^{-At})^{-1} = [\Phi(-t)]^{-1}.$$

$$\Phi(t_1+t_2) = e^{A(t_1+t_2)} = \Phi(t_1) \Phi(t_2) = \Phi(t_2) \Phi(t_1).$$

15. What is sampled data control system?

When the signal or information at any or some points in a system is in the form of discrete pulses, then the system is called discrete data system or sampled data system.

16. What is Nyquist rate?

The Sampling frequency equal to twice the highest frequency of the signal is called as Nyquist rate. $f_s = 2f_m$.

17. What is similarity transformation?

The process of transforming a square matrix A to another similar matrix B by a transformation $P^{-1}AP = B$ is called similarity transformation. The matrix P is called transformation matrix.

18. What is meant by diagonalization?

The process of converting the system matrix A into a diagonal matrix by a similarity transformation using the modal matrix M is called diagonalization.

19. What is modal matrix?

The modal matrix is a matrix used to diagonalize the system matrix. It is also called diagonalization matrix.

If A = system matrix.

M = Modal matrix

And M^{-1} = inverse of modal matrix.

Then $M^{-1}AM$ will be a diagonalized system matrix.

20. How the modal matrix is determined?

The modal matrix M can be formed from eigenvectors. Let $m_1, m_2, m_3 \dots m_n$ be the eigenvectors of the nth order system. Now the modal matrix M is obtained by arranging all the eigenvectors column wise as shown below.

Modal matrix, $M = [m_1, m_2, m_3 \dots m_n]$.

21. What is the need for controllability test?

The controllability test is necessary to find the usefulness of a state variable. If the state variables are controllable then by controlling (i.e. varying) the state variables the desired outputs of the system are achieved.

22. What is the need for observability test?

The observability test is necessary to find whether the state variables are measurable or not. If the state variables are measurable then the state of the system can be determined by practical measurements of the state variables.

23. State the condition for controllability by Gilbert's method.

Case (i) when the eigen values are distinct

Consider the canonical form of state model shown below which is obtained by using the transformation $X=MZ$.

$$\dot{X} = \Lambda Z + U$$

$$Y = Z + DU$$

Where, $\Lambda = M^{-1}AM$; $C = CM$, $B = M^{-1}B$ and $M =$ Modal matrix.

In this case the necessary and sufficient condition for complete controllability is that, the matrix must have no row with all zeros. If any row of the matrix is zero then the corresponding state variable is uncontrollable.

Case (ii) when eigen values have multiplicity

In this case the state modal can be converted to Jordan canonical form shown below

$$\dot{X} = JZ + U$$

$$Y = Z + DU \text{ Where, } J = M^{-1}AM$$

In this case the system is completely controllable, if the elements of any row of that correspond to the last row of each Jordan block are not all zero.

24. State the condition for observability by Gilbert's method.

Consider the transformed canonical or Jordan canonical form of the state model shown below which is obtained by using the transformation, $X =MZ$

$$\dot{X} = \Lambda Z + U$$

$$Y=Z + DU \text{ (Or)}$$

$$= JZ + U$$

$Y=Z + DU$ where $=CM$ and M =modal matrix.

The necessary and sufficient condition for complete observability is that none of the columns of the matrix be zero. If any of the column is of has all zeros then the corresponding state variable is not observable.

25. State the duality between controllability and observability.

The concept of controllability and observability are dual concepts and it is proposed by kalman as principle of duality. The principle of duality states that a system is completely state controllable if and only if its dual system is completely state controllable if and only if its dual system is completely observable or vice versa.

26. What is the need for state observer?

In certain systems the state variables may not be available for measurement and feedback. In such situations we need to estimate the unmeasurable state variables from the knowledge of input and output. Hence a state observer is employed which estimates the state variables from the input and output of the system. The estimated state variable can be used for feedback to design the system by pole placement.

27. How will you find the transformation matrix, P_0 to transform the state model to observable phase variable form?

i. Compute the composite matrix for observability, Q_0

ii. Determine the characteristic equation of the system $|\lambda I - A| = 0$.

iii. Using the coefficients a_1, a_2, \dots, a_{n-1} of characteristic equation form a matrix, W .

iv. Now the transformation matrix, P_0 is given by $P_0 = W Q_0$

T.

28. Write the observable phase variable form of state model.

The observable phase variable form of state model is given by the following equations

$$= A_0Z + B_0u.$$

$$Y = C_0 Z + D u$$

Where, $A_0 =$, $B_0 =$ and $C_0 = [0 \ 0 \ \dots \ 0 \ 1]$

29. What is the pole placement by state feedback?

The pole placement by state feedback is a control system design technique, in which the state variables are used for feedback to achieve the desired closed loop poles.

30. How control system design is carried in state space?

In state space design of control system, any inner parameter or variable of a system are used for feedback to achieve the desired performance of the system. The performance of the system is related to the location of closed loop poles. Hence in state space design the closed loop poles are placed at the desired location by means of state feedback through an appropriate state feedback gain matrix, K .

EC 3351-CONTROL SYSTEMS

Questions and Answers

PART-B

Unit - I Systems Components And Their Representation

1. Determine the transfer function $Y_2(S)/F(S)$ of the system shown in fig.

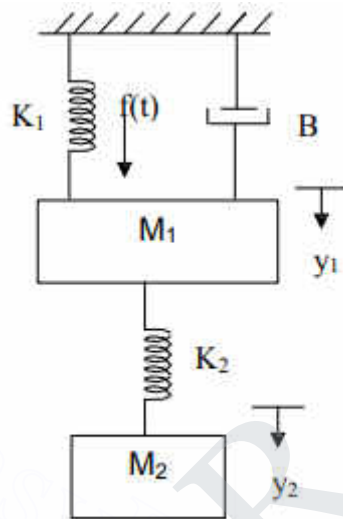

2. Explain the basic elements of control systems with examples?

3. Write the rules for block diagram reduction techniques?

4. Write short notes on

a) Mechanical translational system

b) Mechanical rotational system

5.i) Explain about signal flow graph. (6)

ii) Find the overall transfer function of the system. Use signal flow graph is shown in figure. (9)

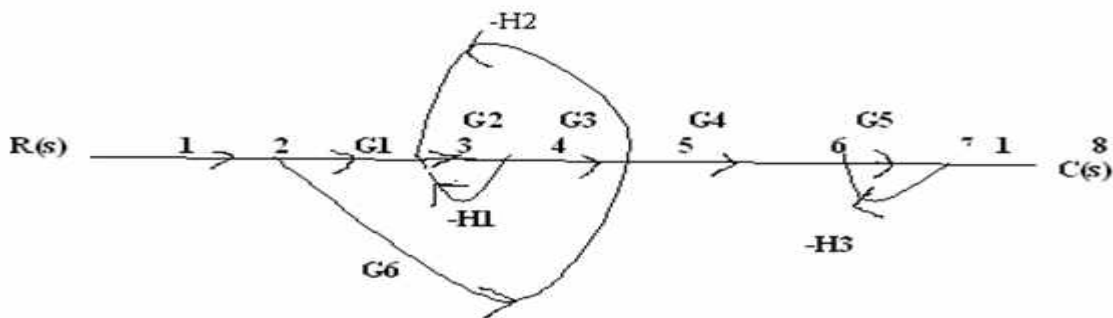

6. Write the differential equations governing the Mechanical system shown in fig 1.1. and determine the transfer function.

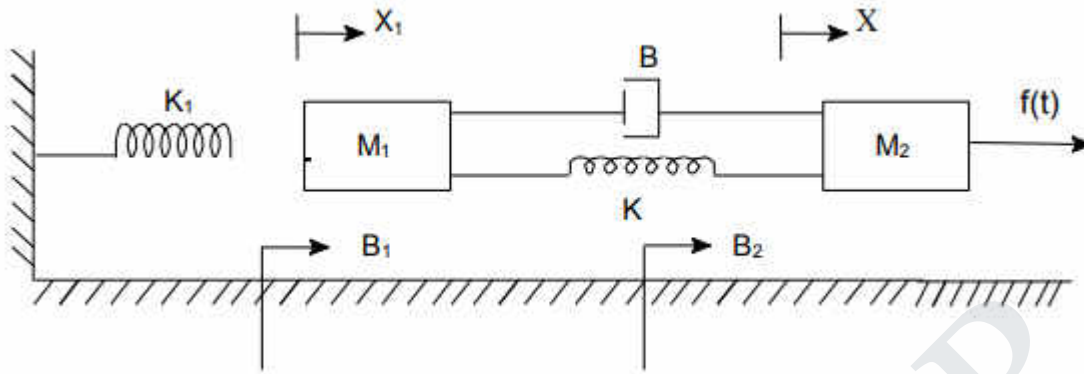

7. Write the differential equations governing the Mechanical rotational system shown in fig. Draw the Torque-voltage and Torque-current electrical analogous circuits.

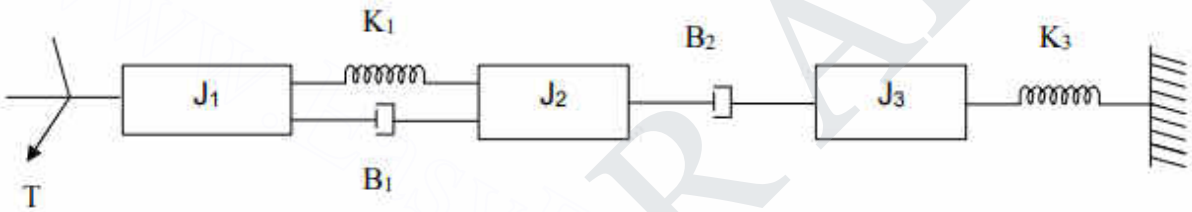

8. Determine the overall transfer function $C(S)/R(S)$ for the system shown in fig.

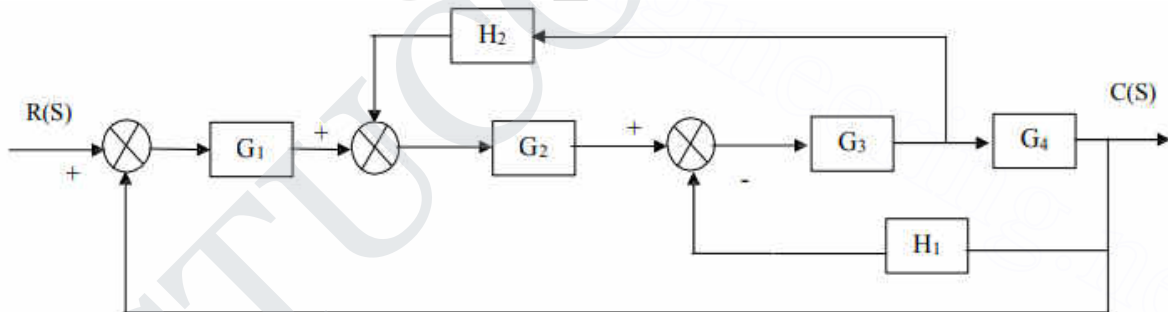

9. Obtain the closed loop transfer function $C(S)/R(S)$ of the system whose block diagram is shown in fig.

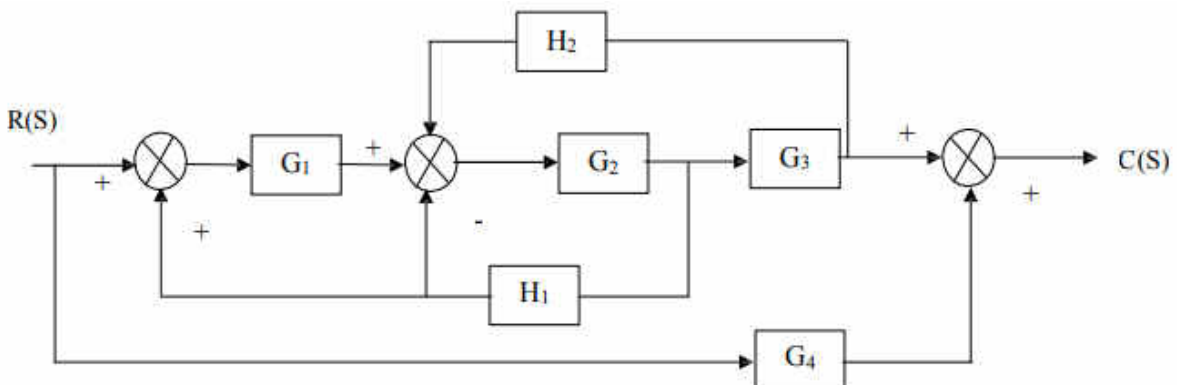

10. Find the overall gain $C(s) / R(s)$ for the signal flow graph shown below.

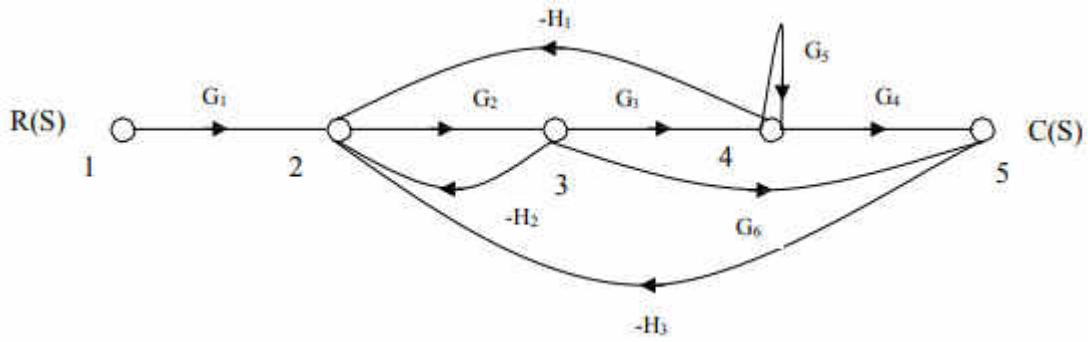

11. Find the overall gain of the system whose signal flow graph is shown in fig.

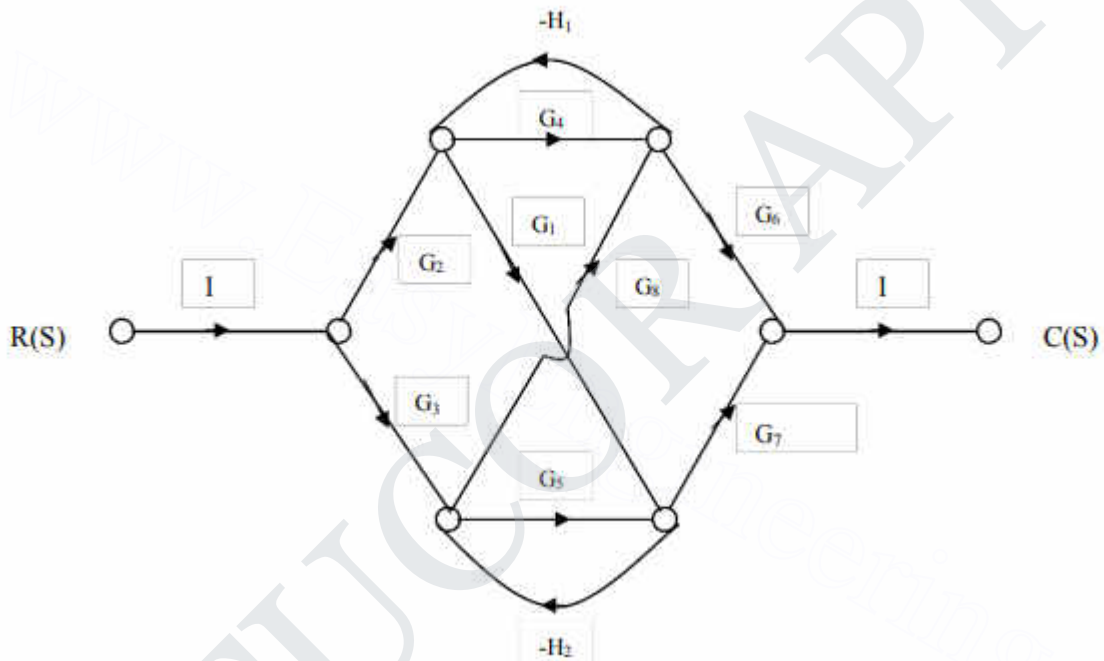

12. Draw a signal flow graph and evaluate the closed loop transfer function of a system whose block is shown in fig.

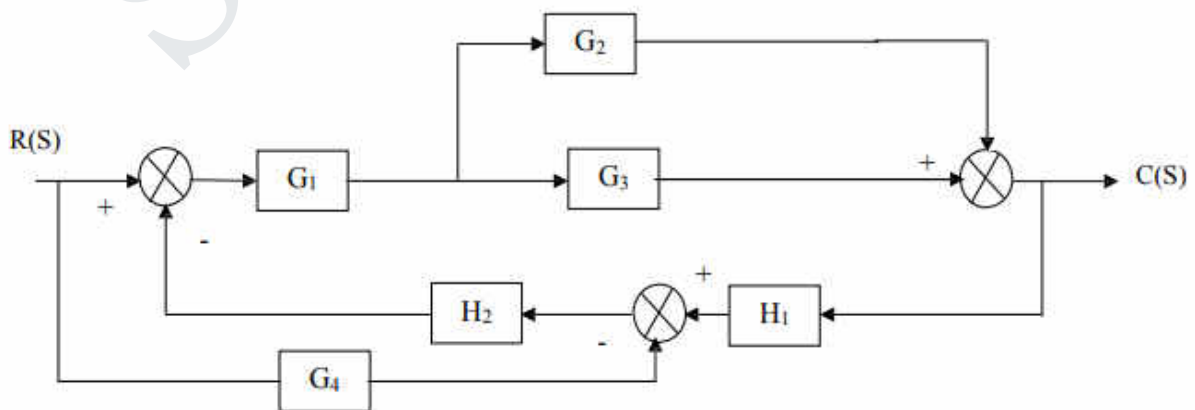

13. (i) Explain DC servo motor.

(ii) Explain the working of AC servomotor in control systems.

14. (i) Explain Synchros and its types.

(ii) Write the rules for block diagram reduction techniques.

15. Write the differential equations governing the mechanical systems shown below. Draw the force-voltage and force-current electrical analogous circuits and verify by writing mesh and node equations.

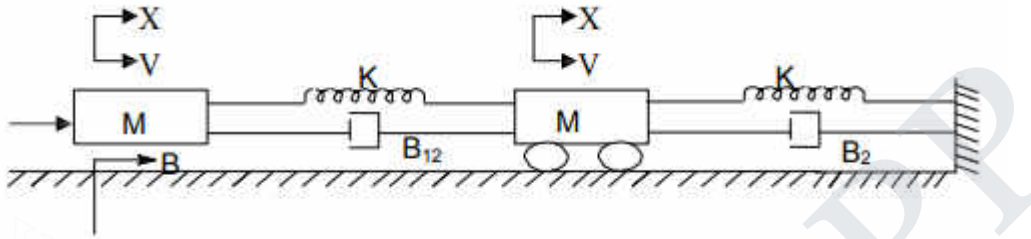

Unit - II Time Response Analysis

- (a) Derive the expressions and draw the response of first order system for unit step input. (8) (b) Draw the response of second order system for critically damped case and when input is unit step. (8)
- Derive the expressions for Rise time, Peak time, and Peak overshoot.
- Measurements conducted on a Servomechanism show the system response to be $c(t) = 1 + 0.2 e^{-60t} - 1.2 e^{-10t}$, when subjected to a unit step. Obtain an expression for closed loop transfer function.
- A unity feedback control system has an open loop transfer function $G(S) = 10/S(S+2)$. Find the rise time, percentage over shoot, peak time and settling time.
- A closed loop servo is represented by the differential equation, where c is the displacement of the output shaft, r is the displacement of the input shaft and $e = r - c$. Determine undamped natural frequency, damping ratio and percentage maximum overshoot for unit step input.
- For a unity feedback control system the open loop transfer function $G(S) = 10(S+2)/S^2(S+1)$. Find (a) position, velocity and acceleration error constants. (b) The steady state error when the input is $R(S)$ where $R(S) = 3/S - 2/S^2 + 1/3S^3$.

7. A positional control system with velocity feedback is shown in fig. What is the response of the system for unit step input.

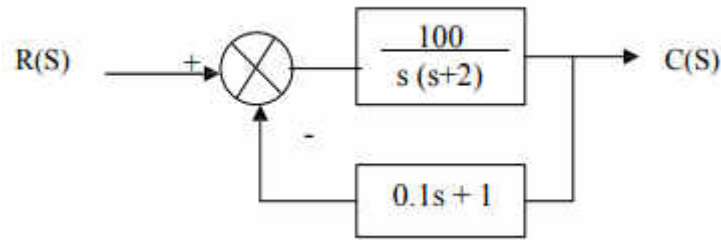

8. . A positional control system with velocity feedback is shown in fig. What is the response $c(t)$ to the unit step input. Given that $\zeta = 0.5$ and also calculate rise time, peak time, Maximum overshoot and settling time.

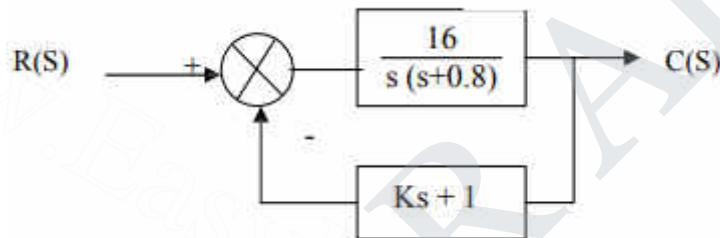

9 .(i) Explain P,PI,PID,PD controllers.

(ii) Derive the expressions for second order system for under damped case and when the input is unit step.

10. The unity feedback system is characterized by an open loop transfer function is $G(S) = K / S(S+10)$. Determine the gain K , so that the system will have a damping ratio of 0.5. For this value of K , determine settling time, Peak overshoot and time to Peak overshoot for a unit-step input.

Unit - III Frequency Response And System Analysis

1. Plot the Bode diagram for the following transfer function and obtain the gain and phase cross over frequencies. $G(S) = 10 / S(1+0.4S) (1+0.1S)$

2. The open loop transfer function of a unity feedback system is $G(S) = 1 / S(1+S) (1+2S)$
Sketch the Polar plot and determine the Gain margin and Phase margin.

3. Sketch the Bode plot and hence find Gain cross over frequency, Phase cross over frequency, Gain margin and Phase margin. $G(S) = 0.75(1+0.2S) / S(1+0.5S) (1+0.1S)$

4. Sketch the Bode plot and hence find Gain cross over frequency, Phase cross over

frequency, Gain margin and Phase margin. $G(S) = 10(S+3)/S(S+2)(S^2+4S+100)$.

5. Sketch the polar plot for the following transfer function .and find Gain cross over frequency, Phase cross over frequency, Gain margin and Phase margin. $G(S) = 10(S+2)(S+4)/S(S^2-3S+10)$

6. Construct the polar plot for the function $GH(S) = 2(S+1)/S^2$. Find Gain cross over frequency, Phase cross over frequency, Gain margin and Phase margin.

7. Plot the Bode diagram for the following transfer function and obtain the gain and phase cross over frequencies. $G(S) = KS^2 / (1+0.2S)(1+0.02S)$. Determine the value of K for a gain cross over frequency of 20 rad/sec.

8. Sketch the polar plot for the following transfer function .and find Gain cross over frequency, Phase cross over frequency, Gain margin and Phase margin. $G(S) = 400/S(S+2)(S+10)$

9. A unity feedback system has open loop transfer function $G(S) = 20/S(S+2)(S+5)$. Using Nichol's chart determine the closed loop frequency response and estimate all the frequency domain specifications.

10. Sketch the Nyquist plot for a system with the open loop transfer function $G(S)H(S) = K(1+0.5S)(1+S) / (1+10S)(S-1)$. determine the range of values of K for which the system is stable.

11. Explain the procedure for lead compensation and lag compensation?

12. Explain the design procedure for lag- lead compensation

Unit - IV Concepts of Stability Analysis

1. Using Routh criterion determine the stability of the system whose characteristics equation is $S^4+8S^3+18S^2+16S+5 = 0$.

2. $F(S) = S^6 + S^5 - 2S^4 - 3S^3 - 7S^2 - 4S - 4 = 0$. Find the number of roots falling in the RHS plane and LHS plane.

3. Draw the Nyquist plot for the system whose open loop transfer function is $G(S)H(S)$

$=K/S (S+2) (S+10)$. Determine the range of K for which closed loop system is stable.

4. Construct Nyquist plot for a feedback control system whose open loop transfer function is given by $G(S)H(S) = 5/ S(1-S)$. comment on the stability of open loop and closed loop transfer function.

5. Sketch the Nyquist plot for a system with the open loop transfer function $G(S) H(S) =K (1+0.5S) (1+S) / (1+10S) (S-1)$. Determine the range of values of K for which the system is stable.

6. Write the short notes on correlation between the time and frequency response?

7. Sketch the root locus for the unity feedback system whose open loop transfer function is $G(S) = K / S (S^2+6S+10)$.

8. Sketch the root locus for the unity feedback system whose open loop transfer function is $G(S) = K (S^2+6S+25) / S(S+1)(S+2)$

9. Sketch the root locus for the unity feedback system whose open loop transfer function is $G(S) = K(S+1.5) / S (S+1) (S+5)$.

10. (i) Construct Routh array and determine the stability of the system represented by the characteristics equation $S^5 +S^4 +2S^3 +2S^2 +3S+5=0$. Comment on the location of the roots of characteristic equation. (8)

(ii) Construct Routh array and determine the stability of the system represented by the characteristics equation $S^7 +9S^6 +24S^4 +24S^3 +24S^2 +23S+15=0$ comment on the location of the roots of characteristic equation.(5)

Unit - V Control System Analysis Using State Variable Methods

1. What are servomotor? Explain in detail their application in control system?

2. Describe the electromechanical – hydraulic control system with derivation of its transfer function?

3. Consider the system given by $Y(S)/U(S)=s+3/s^2+3s+2$, Obtain state space representation in diagonal canonical form.

4. Describe the necessity of State space analysis?

5. Explain in detail Spectrum analysis of sampling process?

6. Write short notes on digital control design using state feedback?

7. Briefly explain the concept of Stability of linear systems?
8. Describe the Concepts of Controllability and Observability in detail.
9. Obtain the state variable representation of an armature Dc servomotor.

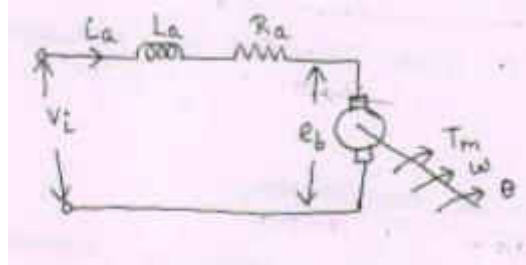

10. Consider a system represented by the differential equation

$$\frac{d^2y}{dt^2} + 4\frac{dy}{dt} + 4y = \frac{du}{dt} + u, \quad y(0) = 2, \quad \dot{y}(0) = 1, \quad u(t) = e^{-4t}, \quad t \geq 0$$