

A Course Material on

Electrical machines I

BASED ON REGULATION 2017

DEPARTMENT OF ELECTRICAL AND ELECTRONICS ENGINEERING

STUCOR APP

EE 8301 ELECTRICAL MACHINES I

S.NO	CONTENT	PAGE NO
CHAPTER I MAGNETIC CIRCUITS AND MAGNETIC MATERIAL		
1.1	Introduction	8
1.2	Magnetic Circuits	8
	1.2.1 Magnetic Material	10
	1.2.2 Magnetic Effect By Electric Current	11
1.3	Laws Governing Magnetic Circuits	11
	1.3.1. Magnetic flux	11
	1.3.2. Magnetic field strength	11
	1.3.3. Flux density	12
	1.3.4. Magneto-Motive Force	12
	1.3.5. Magnetic Reluctance	12
	1.3.6. Residual Magnetism	12
	1.3.7. Magnetic Saturation	12
	1.3.8. End Rule	12
	1.3.9. Lenz's Law	13
	1.3.10. Electro magnetic induction	13
	1.3.11. Fleming's Right Hand Rule	13
1.4	Flux Linkage, Inductance and Energy	13
	1.4.1. Flux Linkage	13
	1.4.2 Inductance and Energy	14
1.5	Statically And Dynamically Induced Emf	14
	1.5.1 Statically Induced Emf	14
	1.5.1.1 Self Inductuced emf	14
	1.5.1.2 Mutually Induced EMF	15
	1.5.2 Dynamically induced EMF	15
1.6	Properties of Magnetic Materials	15
	1.6.1 Magnetic Hysteresis	15
	1.6.2 Hysteresis Loop	16
1.7	Iron or Core losses	16
	1.7.1. Hysteresis loss	16
	1.7.2 Eddy current loss	17
	1.7.3 Mechanical losses	18
1.8	Ac Operation Of Magnetic Circuits	18
1.9	Transformer As A Magnetically Coupled Circuit	19
1.10	Solved problems	21
CHAPTER 2 TRANSFORMER		
2.1	Principle Of Operation	26
	2.1.1 Basic Principle	26
	2.1.2 An ideal Transformer	32
	2.1.3 Induction Law	32
2.2	Equivalent Circuit	34
2.3	Transformer Losses	35
2.4	Transformer Tests	37

2.4.1	Open-circuit or No-load Test	37
2.4.2	Short-circuit or Impedance Test.	38
2.5	Efficiency	39
2.6	Voltage Regulation	41
2.6.1	Circuit Diagram	42
2.6.2	Procedure	42
2.6.3	Observation Table	42
2.6.4	Calculation	42
2.6.5	Discussion	42
2.7	Auto Transformer	43
2.8	Three-phase autotransformer connection	44
2.8.1	Design, Vector group	44
2.8.2	Three-Leg Transformer	45
2.9	Parallel Operation Of Transformers	46
2.10	Tap Changing	48
	SOLVED PROBLEMS	52
CHAPTER- 3 ELECTROMECHANICAL ENERGY CONVERSION AND CONCEPTS INROTATING MACHINES		
3.1	Energy In Magnetic Systems	58
3.1.1	Electromechanical-Energy-Conversion Principles	58
3.1.2	Forces and Torques in Magnetic Field Systems	58
3.2	The Field Energy	59
3.2.1	Energy Balance	59
3.3	The Co Energy	60
3.4	Force In A Singly Excited Magnetic Field System	62
3.4.1	Model & Analysis	62
3.5	Force In A Multiply Excited Magnetic Field System	64
3.6	MMf Of Distributed Windings	67
3.6.1	Alternating Field Distribution	67
3.6.2	Rotating field	68
3.6.3	Three-phase winding	68
3.6.4	Determination of slot mmf for different moments (temporal)	69
3.7	Magnetic Fields In Rotating Machines	69
3.7.1	Winding factor	69
3.7.2	Distribution factor	72
3.7.3	Pitch factor	73
3.8	Rotating Mmf Waves	73
3.8.1	Voltage induction caused by influence of rotating field	74
3.8.2	Flux linkage	75
3.8.3	Induced voltage, slip	75
3.9	Torque In Ac And Dc Machines	76
	SOLVED PROBLEMS	78
CHAPTER 4 DC GENERATOR		
4.1	Principles Of D.C. Machines	83
4.2	Construction of DC. Machines	83
4.2.1	Frame	83
4.2.2	Yoke	83
4.2.3	End Shields or Bearings	84
4.2.4	Main poles	84
4.2.5	Armature	84
4.2.6	Commutator	85

4.3	Lap Winding	86
4.4	Wave Winding	87
4.5	EMF Equation	88
4.6	Armature reaction	89
4.7	Methods Of Excitation	90
4.8	Commutation And Interpoles	91
4.9	Generator Characteristics	92
	4.9.1. Open Circuit Characteristic (O.C.C.)	92
	4.9.2. Internal or Total characteristic (E/I_a)	92
	4.9.3. External Characteristic (V/I_L)	92
	4.9.4. No-load Saturation Characteristic (E_0/I_f)	93
	4.9.5. Separately-Excited Generator	93
	4.9.6. External Characteristic (V/I)	94
CHAPTER 5	DC MOTORS	
5.1	Principle	96
5.2	Operation	96
5.3	Types of DC motor	96
5.4	Motor Characteristics	98
	5.4.1 Torque/Speed Curves	98
	5.4.2 Power/Torque And Power/Speed Curves	100
5.5	Speed Control Of Dc Shunt Motor	101
	5.5.1 Speed Control by Varying Armature Resistance	101
	5.5.2 Speed Control by Varying Field Current	102
5.6	Starting Of Dc Motors	103
5.7	Three Point Starter	104
5.8	Four-Point Starter	106
5.9	Swinburne's Test	106
5.10	Hopkinson's test	109
	SOLVED PROBLEMS	115
	GLOSSARY	118
	TWO MARK QUESTION WITH ANSWER	120
	UNIVERSITY QUESTION BANK	129

AIM

To expose the students to the basic principles of Electro mechanical Energy Conversion in Electrical Apparatus and the operation of Transformers and DC Machines.

OBJECTIVES:

- To introduce techniques of magnetic-circuit analysis and introduce magnetic materials
- To familiarize the constructional details, the principle of operation, prediction of performance, the methods of testing the transformers and three phase transformer connections.
- To study the working principles of electrical machines using the concepts of electromechanical energy conversion principles and derive expressions for generated voltage and torque developed in all Electrical Machines.
- To study the working principles of DC machines as Generator types, determination of their no load / load characteristics, starting and methods of speed control of motors.
- To estimate the various losses taking place in D.C. Motor and to study the different testing methods to arrive at their performance.

UNIT I MAGNETIC CIRCUITS AND MAGNETIC MATERIALS

Magnetic circuits –Laws governing magnetic circuits - Flux linkage, Inductance and energy – Statically and Dynamically induced EMF - Torque – Properties of magnetic materials, Hysteresis and Eddy Current losses - AC excitation, introduction to permanent magnets-Transformer as a magnetically coupled circuit..

UNIT II TRANSFORMERS 9

Construction – principle of operation – equivalent circuit parameters – phasor diagrams, losses – testing – efficiency and voltage regulation-all day efficiency-Sumpner's test, per unit representation – inrush current - three phase transformers-connections – Scott Connection – Phasing of transformer– parallel operation of three phase transformers-auto transformer – tap changing transformers- tertiary Winding

UNIT III ELECTROMECHANICAL ENERGY CONVERSION AND CONCEPTS IN ROTATING MACHINES

Energy in magnetic systems – field energy, co energy and mechanical force – singly and multiply excited systems. Energy in magnetic system – Field energy and coenergy -force and torque equations – singly and multiply excited magnetic field systems-mmf of distributed windings – Winding Inductances-, magnetic fields in rotating machines – rotating mmf waves – magnetic saturation and leakage fluxes.

UNIT IV DC GENERATORS

Construction and components of DC Machine – Principle of operation - Lap and wave windings-EMF equations– circuit model – armature reaction –methods of excitation-commutation and inter poles - compensating winding –characteristics of DC generators.

UNIT V DC MOTORS 9

Principle and operations - types of DC Motors – Speed Torque Characteristics of DC Motors-starting and speed control of DC motors –Plugging, dynamic and regenerative braking- testing and efficiency – Retardation test- Swinburne's test and Hopkinson's test - Permanent magnet dc motors(PMDC)-DC Motor applications

TEXT BOOKS

1. Nagrath I. J and Kothari D. P. 'Electric Machines', Tata McGraw Hill Publishing Company Ltd,1990.

2. P.S. Bimbhra, 'Electrical Machinery', Khanna Publishers, 2003.

REFERENCES

1. Fitzgerald.A.E., Charles KingselyJr, Stephen D.Umans, 'Electric Machinery', McGraw Hill BooksCompany, 1992.
2. P. C. Sen., 'Principles of Electrical Machines and Power Electronics', John Wiley&Sons, 1997.
3. K. Murugesh Kumar, 'Electric Machines', Vikas publishing house Pvt Ltd, 2002.

STUCOR APP

CHAPTER- 1

MAGNETIC CIRCUITS AND MAGNETIC MATERIALS

Introduction

The law of conservation of energy states that the energy cannot be related or destroyed but it can be converted from one form to other. An electrical energy does not occur naturally and also cannot be stored. Hence the efforts are made to generate it continuously to meet the large demands. But to generate an electrical energy means to convert some other form of energy into an electrical form, according to law of conservation of energy. A commonly used method to generate an electrical energy is converting mechanical energy into electrical with the help of a rotating device. Such a machine which converts the mechanical energy into an electrical energy is called a generator. The input mechanical energy can be achieved from steam turbines, steam engines or using potential energy of water to run hydraulic turbines. Such a device which inputs a mechanical energy to a generator is called a prime mover. While converting energy from mechanical to electrical form, some losses take place. The losses are kept to minimum value by properly designing the machine. Practically the efficiencies of large generators are above 90 %

Magnetic Circuits

In a magnetic circuit, the magnetic lines of force leaves the north poles passes through the entire circuit and return the starting point. A magnetic circuit usually consist of materials having high permeability such as iron , soft steel etc., These materials offer very small opposition to the flow of magnetic flux . consider a coil of N turns would on an iron core

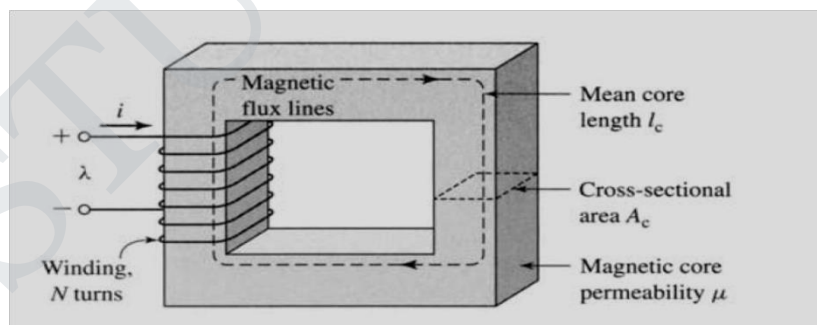

Ampere’s law

$$\oint_C \vec{H} \cdot d\vec{l} = \int_S \vec{J} \cdot d\vec{a} \quad \vec{H} : \text{magnetic field intensity vector, } \vec{J} : \text{current density.}$$

$$\oint_S \vec{B} \cdot d\vec{a} = 0 \quad \vec{B} : \text{magnetic flux density vector.} \Rightarrow \text{magnetic flux density is conserved}$$

$$\vec{B} = \mu \vec{H} \quad \mu = \mu_r \mu_0 \text{ magnetic permeability of medium.}$$

$$\mu_0 : \text{permeability of free space } \mu_0 = 4\pi \times 10^{-7}$$

$$\mu_r : \text{relative permeability}$$

$$\oint_C \vec{H} \cdot d\vec{l} = \int_S \vec{J} \cdot d\vec{a} = Ni = F \quad : \text{magnetomotive force (mmf, ampere-turns).}$$

Magnetic flux crossing surface S : $\phi = \int_S \vec{B} \cdot d\vec{a}$ (Weber, Wb)

$\phi_c \cong B_c A_c$ ϕ_c : flux in core,
 B_c : flux density in the core
 A_c : cross-sectional area of the core.

$$\begin{aligned} \oint_C \vec{H} \cdot d\vec{l} \cong H_c l_c &\Rightarrow \frac{B_c l_c}{\mu} = Ni = F \Rightarrow \frac{\phi}{\mu A_c} l_c = F \\ \Rightarrow \phi = \frac{F}{\mathfrak{R}} \quad \mathfrak{R} = \frac{l_c}{\mu A_c} &: \text{reluctance} \end{aligned}$$

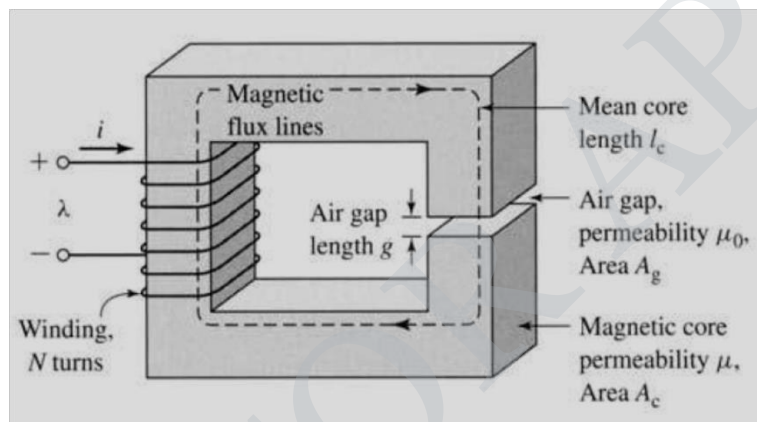

Fig. 1.2 Magnetic circuit with air gap.

Flux is the same in the magnetic core and the air-gap.

$$\Rightarrow \begin{aligned} B_c &= \frac{\phi}{A_c} \quad \text{flux density in the magnetic core.} \\ B_g &= \frac{\phi}{A_g} \quad \text{flux density in the air-gap.} \end{aligned}$$

$$\text{mmf} \quad \oint_C \vec{H} \cdot d\vec{l} = H_c l_c + H_g g = Ni = F \Rightarrow F = \frac{B_c l_c}{\mu} + \frac{B_g g}{\mu_0} = \phi \left(\frac{l_c}{\mu A_c} + \frac{g}{\mu_0 A_g} \right)$$

$$\Rightarrow F = \phi(\mathfrak{R}_c + \mathfrak{R}_g) \Rightarrow \phi = \frac{F}{\mathfrak{R}_c + \mathfrak{R}_g}$$

\mathfrak{R}_c : reluctance of core, \mathfrak{R}_g : reluctance of air-gap.

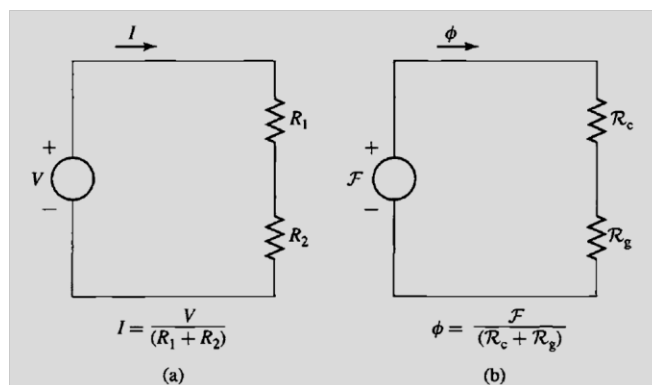

Fig 1.1 Analogy between electric and magnetic circuits.

magnetism plays an important role in electricity. Electrical appliances like Generator, Motor, Measuring instruments and Transformer are based on the electromagnetic principle and also the important components of Television, Radio and Aero plane are working on the same principle.

Magnetic Material

Magnetic materials are classified based on the property called permeability as

1. Dia Magnetic Materials
2. Para Magnetic Materials
3. Ferro Magnetic Materials

1. Dia Magnetic Materials

The materials whose permeability is below unity are called Dia magnetic materials. They are repelled by magnet.

Ex. Lead, gold, copper, glass, mercury

2. Para Magnetic Materials

The materials with permeability above unity are called Para magnetic materials. The force of attraction by a magnet towards these materials is low.

Ex.: Copper Sulphate, Oxygen, Platinum, Aluminum.

3. Ferro Magnetic Materials

The materials with permeability thousands of times more than that of paramagnetic materials are called Ferro magnetic materials. They are very much attracted by the magnet.

Ex. Iron, Cobalt, Nickel.

Permanent Magnet

Permanent magnet means, the magnetic materials which will retain the magnetic property at all times permanently. This type of magnets is manufactured by aluminum, nickel, iron, cobalt steel (ALNICO).

To make a permanent magnet a coil is wound over a magnetic material and DC supply is passed through the coil.

Electro Magnet

Insulated wire wound on a bobbin in many turns and layers in which current is flowing and a soft iron piece placed in the bobbin is called electromagnet.

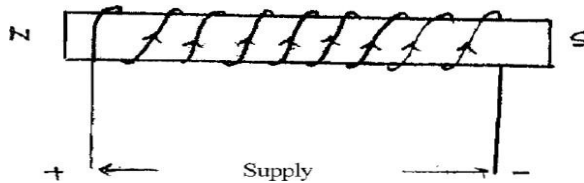

Figure 1.2

This is used in all electrical machines, transformers, electric bells. It is also used in a machine used by doctors to pull out iron filing from eyes, etc.

Magnetic Effect By Electric Current

If current passes through a conductor magnetic field is set up around the conductor. The quantity of the magnetic field is proportion to the current. The direction of the magnetic field is found by right hand rule or max well's corkscrew rule. Magnetic Flux The magnetic flux in a magnetic circuit is equal to the total number of lines existing on the cross-section of the magnetic core at right angle to the direction of the flux.

$$H = \frac{\Phi}{\mu_0 \mu_r a l}$$

Where,

- Φ - total flux
- N - number of turns
- I - current in amperes
- S - reluctance
- μ - permeability of free space
- μ_0 - relative permeability
- a - magnetic path cross-sectional area in m^2
- l - length of magnetic path in metres

Laws Governing Magnetic Circuits

Magnetic flux:

The magnetic lines of force produced by a magnet is called magnetic flux. It is denoted by ϕ and its unit is Weber.

Magnetic field strength

This is also known as field intensity, magnetic intensity or magnetic field, and is represented by the letter H. Its unit is ampere turns per metre.

$$H = \frac{NI}{l}$$

Flux density

The total number of lines of force per square metre of the cross-sectional area of the magnetic core is called flux density, and is represented by the symbol B. Its SI unit (in the MKS system) is tesla (weber per metre square).

$$B = \frac{\phi}{A}$$

where

ϕ - total flux in webers

A - area of the core in square metres

B - flux density in weber/metre square.

1.3.4 .Magneto-Motive Force

The amount of flux density setup in the core is dependent upon five factors - the current, number of turns, material of the magnetic core, length of core and the cross-sectional area of the core. More current and the more turns of wire we use, the greater will be the magnetizing effect. We call this product of the turns and current the magneto motive force (mmf), similar to the electromotive force (ernf).

$$MMF = NI \text{ ampere - turns}$$

Where mmf is the magneto motive force in ampere turns

N is the number of turns, A.

Magnetic Reluctance

In the magnetic circuit there is something analogous to electrical resistance, and is called reluctance, (symbol S). The total flux is inversely proportional to the reluctance and so if we denote mmf by ampere turns. we can write

$$S = \frac{l}{\mu_r \mu_0 a}$$

Where, S - reluctance

l - length of the magnetic path in meters

μ_0 - permeability of free space

μ_r - relative permeability

a - cross-sectional area

Residual Magnetism

It is the magnetism which remains in a material when the effective magnetizing force has been reduced to zero.

Magnetic Saturation

The limit beyond which the strength of a magnet cannot be increased is called magnetic saturation.

End Rule

According to this rule the current direction when looked from one end of the coil

is in clock wise direction then that end is South Pole. If the current direction is in anti clock wise direction then that end is North Pole.

Len's Law

When an emf is induced in a circuit electromagnetically the current set up always opposes the motion or change in current which produces it.

Electro magnetic induction

Electromagnetic induction means the electricity induced by the magnetic field

Faraday's Laws of Electro Magnetic Induction

There are two laws of Faraday's laws of electromagnetic induction. They are,

1) First Law 2) Second Law

First Law

Whenever a conductor cuts the magnetic flux lines an emf is induced in the conductor.

Second Law

The magnitude of the induced emf is equal to the rate of change of flux-linkages.

Fleming's Right Hand Rule

This rule is used to find out the direction of dynamically induced emf. According to the rule hold out the right hand with the Index finger middle finger and thumb at the right angles to each others. If the index finger represents the direction of the lines of flux, the thumb points in the direction of motion then middle finger points in the direction of induced current.

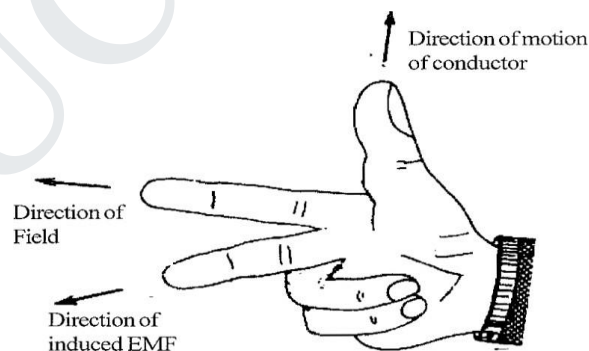

Figure 1.3 Fleming's Right Hand Rule

Flux Linkage, Inductance and Energy

1.4.1. Flux Linkage

When flux is changing with time and relative motion between the coils flux exist between both the coils or conductors and emf induces in both coil and the total induced emf e is given as

$$e = \oint (\mathbf{v} \times \mathbf{B}) \cdot d\mathbf{l} - \int_s \frac{\partial \mathbf{B}}{\partial t} \cdot d\mathbf{s}$$

1.4.2 Inductance and Energy

A coil wound on a magnetic core, is used frequently used in electric circuits. The coil may be representsd by an ideal circuit element called inductance which is defined as the flux linkage of the coil per ampere of its circuit

$$\text{Flux linkage} \quad \lambda = N\Phi$$

$$\text{Inductance} \quad L = \frac{\lambda}{i}$$

$$L = \frac{N\Phi}{i} = \frac{NBA}{i} = \frac{N\mu HA}{i}$$

$$= \frac{N\mu HA}{Hl/N} = \frac{N^2}{l/\mu A}$$

Statically And Dynamically Induced Emf.

Induced electro motive forces are of two types. They are,

- i) Dynamically induced emf.
- ii) Statically induced emf .

Statically Induced Emf

Statically Induced emf is of two types. They are

- 1 .Self induced emf
2. Mutually induced emf.

Self Inductuced emf

Self induction is that phenomenon where by a change in the current in a conductor induces an emf in the conductor itself. i.e. when a conductor is given current, flux will be produced, and if the current is changed the flux also changes, as per Faraday's law when there is a change of flux, an emf will be induced. This is called self induction. The induced emf will be always opposite in direction to the applied emf. The opposing emf thus produced is called the counter emf of self induction.

Uses of Self induction

- .1. In the fluorescent tubes for starting purpose and to reduce the voltage.
2. In regulators, to give reduced voltage to the fans.
3. In lightning arrester.
4. In auto- transformers.
5. In smooth choke which is used in welding plant.

Mutually Induced EMF

It is the electromagnetic induction produced by one circuit in the near by second circuits due to the variable flux of the first circuit cutting the conductor of the second circuit, that means when two coils or circuits are kept near to each other and if current is given to one circuit and it is changed, the flux produced due to that current which is linking both the coils or circuits cuts both the coils, an emf will be produced in both the circuits. The production of emf in second coil is due to the variation of current in first coil known as mutual induction.

Uses:

1. It is used in ignition coil which is used in motor car.
2. It is also used in inductance furnace.
3. It is used for the principle of transformer

Dynamically induced EMF

Dynamically induced **emf** means an emf induced in a conductor when the conductor moves across a magnetic field. The Figure shows when a conductor "A" with the length "L" moves across a "B" wb/m².

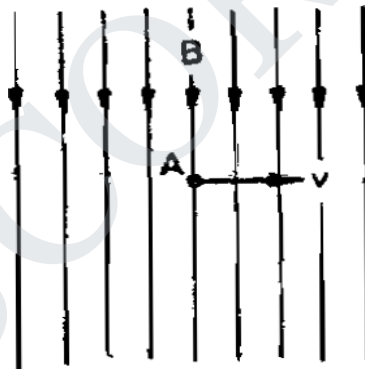

Figure1.4 Dynamically induced emf.

Flux density with "V" velocity, then the dynamically induced emf is induced in the conductor. This induced emf is utilized in the generator. The quantity of the emf can be calculated using the equation

$$\text{emf} = Blv \text{ volt}$$

Properties of Magnetic Materials

Magnetic Hysteresis

It may be defined as the lagging of magnetization or Induction flux density (B) behind the magnetizing force (H). It may also be defined as a quality of a magnetic substance due to which energy is dissipated in it on the reversal of its magnetism

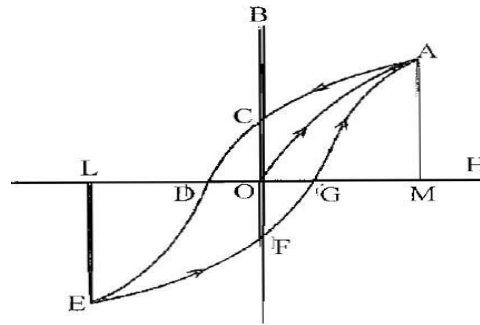

Fig 1.5 Magnetic Hysteresis loop

Hysteresis Loop

Let us take a un magnetized bar of iron AB and magnetize in by placing it within the magnetizing field of a solenoid (H). The Field can be increased or decreased by increasing or decreasing current through it. Let 'H' be increased in step from zero up to a certain maximum value and the corresponding of induction flux density (B) is noted. If we plot the relation between H and B, a curve like OA, as shown in Figure, is obtained. The material becomes magnetically saturated at $H = OM$ and has, at that time, a maximum flux density, established through it. If H is now decreased gradually (by decreasing solenoid current) flux density B will not decrease along AO (as might be expected) but will decrease less rapidly along AC. When it is Zero B is not zero, but has a definite value = OC. It means that on removing the magnetizing force H, the iron bar is not completely demagnetized. This value of B (=OC) is called the residual flux density.

To demagnetize the iron bar we have to apply the magnetizing force H in the reverse direction. When H is reversed by reversing current through the solenoid, then B is reduced to Zero at point D where $H = OD$. This value of H required to wipe off residual magnetism is known as coercive force and is a measure of the coercivity of materials i.e. its 'tenacity' with which it holds on to its magnetism. After the magnetization has been reduced to zero value of H is further increased in the negative i.e. reverse direction, the iron bar again reaches a state of magnetic saturation represented by point E. By taking H back from its value corresponding to negative saturation (=OL) to its value for positive saturation (=OM), a similar curve EFGA is obtained. If we again start from G, the same curve GACDEFG is obtained once again. It is seen that B always lags behind H the two never attain zero value simultaneously. This lagging of B, behind H is given the name 'Hysteresis' which literally means 'to lag behind.' The closed Loop ACDEFGA, which is obtained when iron bar is taken through one complete cycle of reversal of magnetization, is known as Hysteresis loop.

Iron or Core losses

These losses occur in the armature of a d.c. machine and are due to the rotation of armature in the magnetic field of the poles.

They are of two types

- (i) hysteresis loss
- (ii) eddy current loss.

1.7.1. Hysteresis loss

Hysteresis loss occurs in the armature of the d.c. machine since any given part of the armature is subjected to magnetic field reversals as it passes under successive poles. Figure. (1.36) shows an armature rotating in two-pole machine. Consider a small

piece ab of the armature. When the piece ab is under N-pole, the magnetic lines pass from a to b. Half a revolution later, the same piece of iron is under S-pole and magnetic lines pass from b to a so that magnetism in the iron is reversed. In order to reverse continuously the molecular magnets in the armature core, some amount of power has to be spent which is called hysteresis loss. It is given by Steinmetz formula. This formula is Hysteresis loss,

$$P_h = B_{\max}^{1.6} f V \text{ watts}$$

where B_{\max} = Maximum flux density in armature

f = Frequency of magnetic reversals

V = Volume of armature in m^3

h = Steinmetz hysteresis co-efficient

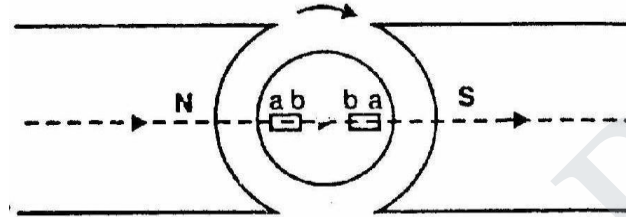

Figure 1.6 Hysteresis loss

In order to reduce this loss in a d.c. machine, armature core is made of such materials which have a low value of Steinmetz hysteresis co-efficient e.g., silicon steel.

Eddy current loss

In addition to the voltages induced in the armature conductors, there are also voltages induced in the armature core. These voltages produce circulating currents in the armature core as shown in Figure. (1.37). These are called eddy currents and power loss due to their flow is called eddy current loss. The eddy current loss appears as heat which raises the temperature of the machine and

lowers its efficiency. If a continuous solid iron core is used, the resistance to eddy current path will be small due to large cross-sectional area of the core. Consequently, the magnitude of eddy current and hence eddy current loss will be large. The magnitude of eddy current can be reduced by making core resistance as high as practical. The core resistance can be greatly increased by constructing the core of thin, round iron sheets called laminations. The laminations are insulated from each other with a coating of varnish. The insulating coating has a high resistance, so very little current flows from one lamination to the other. Also, because each lamination is very thin, the resistance to current flowing through the width of a lamination is also quite large. Thus laminating a core increases the core resistance which decreases the eddy current and hence the eddy current loss.

$$\text{Eddy current loss, } P_e = K_e B_{\max}^2 f^2 t^2 V \text{ watts}$$

where ,

K_e = Constant

B_{\max} = Maximum flux density in Wb/m^2

f = Frequency of magnetic reversals in Hz

t = Thickness of lamination in m

V = Volume of core in m^3

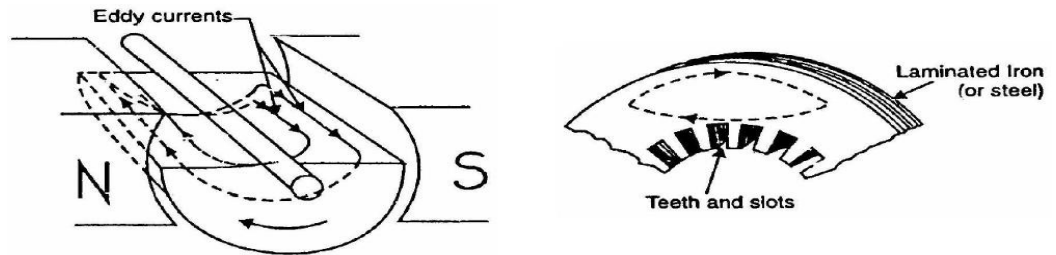

Figure 1.7 Eddy current loss

It may be noted that eddy current loss depends upon the square of lamination thickness. For this reason, lamination thickness should be kept as small as possible.

Mechanical losses

These losses are due to friction and windage.

(i) friction loss e.g., bearing friction, brush friction etc.

(ii) windage loss i.e., air friction of rotating armature.

These losses depend upon the speed of the machine. But for a given speed, they are practically constant.

Note. Iron losses and mechanical losses together are called stray losses

Eddy current

When the armature with conductors rotates in the magnetic field and cuts the magnetic lines, an emf will be induced in the conductors. As the armature is made of a metal and metal being a conductor, emf will be induced in that metal also and circulate the current called eddy current. These current produces some effects which can be utilized. This current are also called as Foucault current. Methods of Minimizing Eddy current always tends to flow at the right angles to the direction of the flux, if the resistance of the path is increased by laminating the cores. The power loss can be reduced because the eddy current loss varies as the square of the thickness of the laminations.

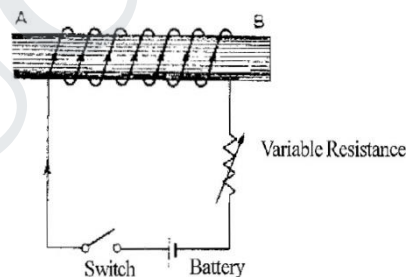

Figure 1.8 Eddy current

1.8 Ac Operation Of Magnetic Circuits

For establishing a magnetic field, energy must be spent, though to energy is required to maintain it. Take the example of the exciting coils of an electromagnet. The energy supplied to it is spent in two ways, (i) Part of it goes to meet I^2R loss and is lost once for all (ii) part of it goes to create flux and is stored in the magnetic field as potential energy, and is similar to the potential energy of a raised weight, when a mass M is raised through a height of H , the potential energy stored in it is mgh . Work is done in raising this mass, but once raised to a certain height. No further expenditure of energy is required to maintain it at that position. This mechanical potential energy can be recovered so can be electric energy stored in a magnetic field. When current through an inductive coil is gradually changed from Zero to a maximum, value then every change

of it is opposed by the self-induced emf. Produced due to this change. Energy is needed to overcome this opposition. This energy is stored in the magnetic field of the coil and is, later on, recovered when those field collapse.

In many applications and machines such as transformer and a.c machines, the magnetic circuits are excited by a.c supply. In such an operation, Inductance plays vital role even in steady state operation though in d.c it acts as a short circuit. In such a case the flux is determined by the a.c voltage applied and the frequency, thus the exciting current has to adjust itself according to the flux so that every time B-H relationship is satisfied.

Consider a coil having N turns wound on iron core as shown in fig

The coil carries an alternating current i varying sinusoidally. Thus the flux produced by the exciting current I is also sinusoidally varying with time.

According to Faraday's law as flux changes with respect to time, the e.m.f gets induced in the coil given by,

$$e = -N \frac{d\phi}{dt}$$

$$E_m = \text{Maximum value} = N \omega \phi_m$$

$$E = \text{r.m.s value} = \frac{E_m}{\sqrt{2}}$$

$$E = \frac{4.44 f N \phi_m}{\sqrt{2}} = 4.44 f N \phi_m$$

$$\text{But } \phi_m = A_c B_m$$

The sign of e.m.f induced must be determined according to len's law, opposing the changes in the flux. The current and flux are in phase as current produces flux instantaneously. Now induced e.m.f is cosine term and thus leads the flux and current by 90° . this is called back e.m.f as it opposes the applied voltage. The resistance drops is very small and is neglecte3d in most of the electromagnetic devices

1.9. Transformer As A Magnetically Coupled Circuit

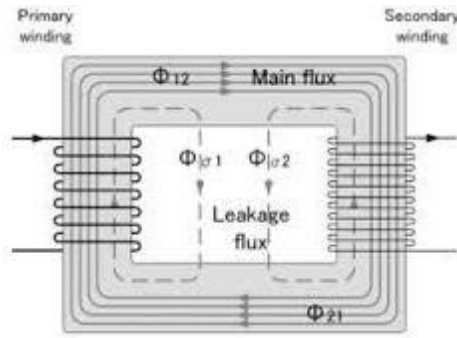

A two winding transformer where R_1 and R_2 are the primary and secondary winding resistance. The primary current i_1 into the dotted terminal produces

$$\text{Core flux} = \phi_{21}$$

$$\text{Leakage flux} = \phi_{\sigma 1}$$

$$\text{Total flux} = \phi_{\sigma 1} + \phi_{21}$$

1.10 Solved problems

Eg .No.1

A magnetic circuit with a single air gap is shown in Fig. 1.24. The core dimensions are:

Cross-sectional area $A_c = 1.8 \times 10^{-3} \text{ m}^2$

Mean core length $l_c = 0.6 \text{ m}$

Gap length $g = 2.3 \times 10^{-3} \text{ m}$

$N = 83 \text{ turns}$

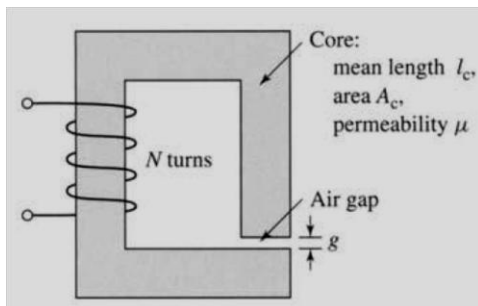

Assume that the core is of infinite permeability ($\mu \rightarrow \infty$) and neglect the effects of fringing fields at the air gap and leakage flux. (a) Calculate the reluctance of the core R_c and that of the gap R_g . For a current of $i = 1.5 \text{ A}$, calculate (b) the total flux ϕ , (c) the flux linkages λ of the coil, and (d) the coil inductance L .

Solution:

$$R_c = 0 \text{ since } \mu \rightarrow \infty \quad R_g = \frac{g}{\mu_0 A_c} = \frac{2.3 \times 10^{-3}}{4\pi \times 10^{-7} \times 1.8 \times 10^{-3}} = 1.017 \times 10^6 \text{ A/Wb}$$

$$\phi = \frac{Ni}{R_c + R_g} = \frac{83 \times 1.5}{1.017 \times 10^6} = 1.224 \times 10^{-4} \text{ Wb}$$

$$\lambda = N\phi = 1.016 \times 10^{-2} \text{ Wb}$$

$$L = \frac{\lambda}{i} = \frac{1.016 \times 10^{-2}}{1.5} = 6.773 \text{ mH}$$

Eg .No.2

Consider the magnetic circuit of with the dimensions of Problem 1.1. Assuming infinite core permeability, calculate (a) the number of turns required to achieve an inductance of 12 mH and (b) the inductor current which will result in a core flux density of 1.0 T.

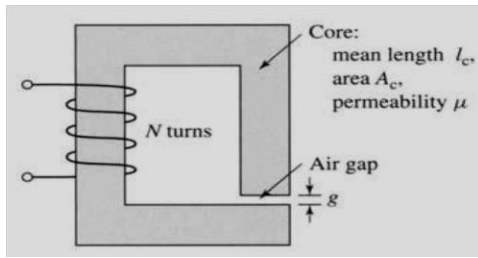

Solution:

$$L = \frac{N^2}{R_g} = 12 \times 10^{-3} \text{ mH} \Rightarrow N = \sqrt{12 \times 10^{-3} \times 1.017 \times 10^6} = 110.47 \Rightarrow N = 110 \text{ turns}$$

$$B_c = B_g = 1.0 \text{ T} \Rightarrow \phi = B_g A = 1.8 \times 10^{-3} \text{ Wb}$$

$$i = \frac{\lambda}{L} = \frac{N\phi}{L} = \frac{110 \times 1.8 \times 10^{-3}}{12 \times 10^{-3}} = 16.5 \text{ A}$$

Eg .No.3

A square voltage wave having a fundamental frequency of 60 Hz and equal positive and negative half cycles of amplitude E is applied to a 1000-turn winding surrounding a closed iron core of $1.25 \times 10^{-3} \text{ m}^2$ cross section. Neglect both the winding resistance and any effects of leakage flux.

(a) Sketch the voltage, the winding flux linkage, and the core flux as a function of time.

(b) Find the maximum permissible value of E if the maximum flux density is not to exceed 1.15 T.

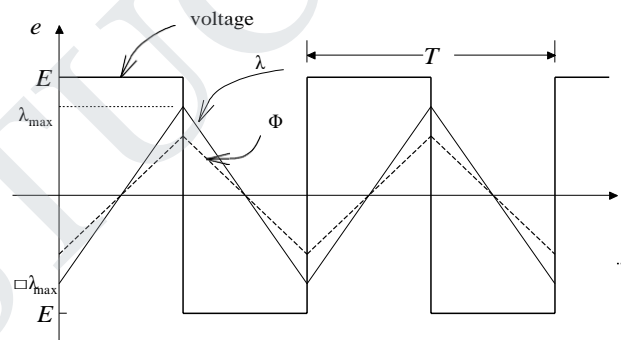

$$e(t) = \frac{d\lambda}{dt} \Rightarrow \lambda = \int e(t).dt \Rightarrow E = \frac{\lambda_{\max} - (-\lambda_{\max})}{T/2} = 4f \lambda_{\max} = 4fN\phi_{\max} = 4fNA_c B_{c \max}$$

$$\Rightarrow E = 4 \times 60 \times 1000 \times 1.25 \times 10^{-3} \times 1.15 = 345 \text{ V}$$

Eg.No.4

In the magnetic circuit of Fig. E1.3a, the relative permeability of the ferro-magnetic material is 1200. Neglect magnetic leakage and fringing. All dimensions are in centimeters, and the magnetic material has a square cross-sectional area. Determine the air gap flux, the air gap flux density, and the magnetic field intensity in the air gap.

Solution

The mean magnetic paths of the fluxes are shown by dashed lines in Fig. E1.3a. The equivalent magnetic circuit is shown in Fig. E1.3b.

$$F_1 = N_1 I_1 = 500 \times 10 = 5000 \text{ At}$$

$$F_2 = N_2 I_2 = 500 \times 10 = 5000 \text{ At}$$

$$\mu_c = 1200\mu_0 = 1200 \times 4\pi \times 10^{-7}$$

$$\begin{aligned} \mathcal{R}_{\text{baf}} &= \frac{l_{\text{baf}}}{\mu_c A_c} \\ &= \frac{3 \times 52 \times 10^{-2}}{1200 \times 4\pi \times 10^{-7} \times 4 \times 10^{-4}} \\ &= 2.58 \times 10^6 \text{ At/Wb} \end{aligned}$$

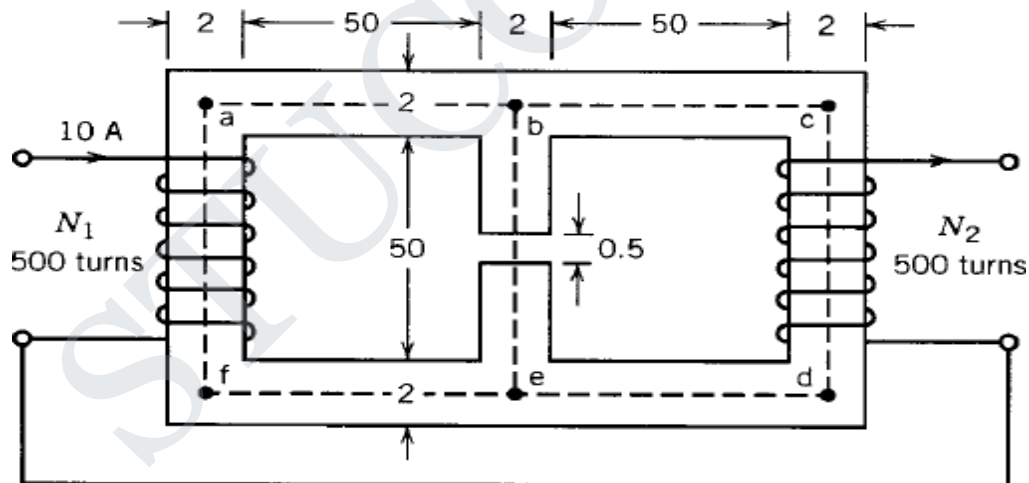

From symmetry

$$\mathcal{R}_{bcde} = \mathcal{R}_{bafe}$$

$$\mathcal{R}_g = \frac{l_g}{\mu_0 A_g}$$

$$= \frac{5 \times 10^{-3}}{4\pi 10^{-7} \times 2 \times 2 \times 10^{-4}}$$

$$= 9.94 \times 10^6 \text{ At/Wb}$$

$$\mathcal{R}_{be(\text{core})} = \frac{l_{be(\text{core})}}{\mu_c A_c}$$

$$= \frac{51.5 \times 10^{-2}}{1200 \times 4\pi 10^{-7} \times 4 \times 10^{-4}}$$

$$= 0.82 \times 10^6 \text{ At/Wb}$$

The loop equations are

$$\Phi_1(\mathcal{R}_{bafe} + \mathcal{R}_{be} + \mathcal{R}_g) + \Phi_2(\mathcal{R}_{be} + \mathcal{R}_g) = F_1$$

$$\Phi_1(\mathcal{R}_{be} + \mathcal{R}_g) + \Phi_2(\mathcal{R}_{bcde} + \mathcal{R}_{be} + \mathcal{R}_g) = F_2$$

$$\Phi_1(13.34 \times 10^6) + \Phi_2(10.76 \times 10^6) = 5000$$

$$\Phi_1(10.76 \times 10^6) + \Phi_2(13.34 \times 10^6) = 5000$$

The air gap flux density is

$$B_g = \frac{\Phi_g}{A_g} = \frac{4.134 \times 10^{-4}}{4 \times 10^{-4}} = 1.034 \text{ T}$$

The magnetic intensity in the air gap is

$$H_g = \frac{B_g}{\mu_0} = \frac{1.034}{4\pi 10^{-7}} = 0.822 \times 10^6 \text{ At/m}$$

Eg.no.5

For the magnetic circuit of Fig. 1.9, $N = 400$ turns.

Mean core length $l_c = 50$ cm.

Air gap length $l_g = 1.0$ mm

Cross-sectional area $A_c = A_g = 15$ cm²

Relative permeability of core $\mu_r = 3000$

$i = 1.0$ A

Find

(a) Flux and flux density in the air gap.

(b) Inductance of the coil.

Solution

$$\begin{aligned} \text{(a)} \quad \mathcal{R}_c &= \frac{l_c}{\mu_r \mu_0 A_c} = \frac{50 \times 10^{-2}}{3000 \times 4\pi \times 10^{-7} \times 15 \times 10^{-4}} \\ &= 88.42 \times 10^3 \text{ AT/Wb} \end{aligned}$$

$$\begin{aligned} \mathcal{R}_g &= \frac{l_g}{\mu_0 A_g} = \frac{1 \times 10^{-3}}{4\pi \times 10^{-7} \times 15 \times 10^{-4}} \\ &= 530.515 \times 10^3 \text{ At/Wb} \end{aligned}$$

$$\begin{aligned} \Phi &= \frac{Ni}{\mathcal{R}_c + \mathcal{R}_g} \\ &= \frac{400 \times 1.0}{(88.42 + 530.515)10^3} \end{aligned}$$

$$B = \frac{\Phi}{A_g} = \frac{0.6463 \times 10^{-3}}{15 \times 10^{-4}} = 0.4309 \text{ T}$$

$$\begin{aligned} \text{b)} \quad L &= \frac{N^2}{\mathcal{R}_c + \mathcal{R}_g} = \frac{400^2}{(88.42 + 530.515)10^3} \\ &= 258.52 \times 10^{-3} \text{ H} \end{aligned}$$

$$\begin{aligned} \text{or } L &= \frac{\lambda}{i} = \frac{N\Phi}{i} = \frac{400 \times 0.6463 \times 10^{-3}}{1.0} \\ &= 258.52 \times 10^{-3} \text{ H} \quad \blacksquare \end{aligned}$$

CHAPTER- 2

TRANSFORMER

Principle Of Operation

A transformer is a device that transfers electrical energy from one circuit to another through inductively coupled conductor. A varying current in the first or primary winding creates a varying magnetic flux in the transformer core, and thus a varying magnetic field through the secondary winding. This varying magnetic field induces a varying electromotive force EMF or voltage in the secondary winding. This effect is called mutual induction.

If a load is connected to the secondary, an electric current will flow in the secondary winding and electrical energy will be transferred from the primary circuit through the transformer to the load. In an ideal transformer, the induced voltage in the secondary winding is in proportion to the primary voltage, and is given by the ratio of the number of turns in the secondary to the number of turns in the primary as follows:

By appropriate selection of the ratio of turns, a transformer thus allows an alternating current (AC) voltage to be "stepped up" by making greater than, or "stepped down" by making less than.

Basic Principle Construction



Figure 2.1 Laminated core transformer showing edge of laminations

Laminated steel cores

Transformer use at power or audio frequencies typically have cores made of high permeability Si steel. The steel has permeability many times that of free and the core thus serves to greatly reduce the magnetizing current and confine the flux to a path which closely couples the windings. Early transformer developers soon realized that cores constructed from solid iron resulted in prohibitive eddy-current losses, and their designs mitigated this effect with cores consisting of bundles of insulated iron wires. Later designs constructed the core by stacking layers of thin steel laminations, a principle that has remained in use. Each lamination is insulated from its neighbors by a thin non-conducting layer of insulation. The universal transformer equation indicates a minimum cross-sectional area for the core to avoid saturation.

The effect of laminations is to confine eddy currents to highly elliptical paths that enclose little flux, and so reduce their magnitude. Thinner laminations reduce losses, but are more laborious and expensive to construct. Thin laminations are generally used on high frequency transformers, with some types of very thin steel laminations able to operate up to 10 kHz.

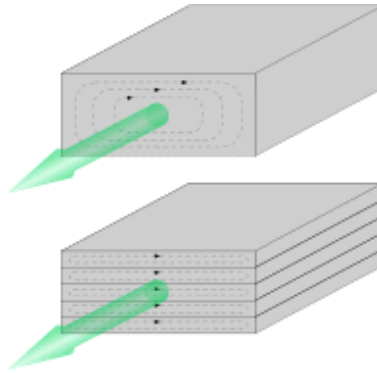

Figure 2.2 laminating the core greatly reduces eddy-current losses

One common design of laminated core is made from interleaved stacks of E-shaped steel sheets capped with shaped pieces, leading to its name of "E-I transformer". Such a design tends to exhibit more losses, but is very economical to manufacture. The cut-core or C-core type is made by winding a steel strip around a rectangular form and then bonding the layers together. It is then cut in two, forming two C shapes, and the core assembled by binding the two C halves together with a steel strap.^[73] They have the advantage that the flux is always oriented parallel to the metal grains, reducing reluctance.

A steel core's permanence means that it retains a static magnetic field when power is removed. When power is then reapplied, the residual field will cause a high inrush until the effect of the remaining magnetism is reduced, usually after a few cycles of the applied alternating current. Over current protection devices such as fuses must be selected to allow this harmless inrush to pass. On transformers connected to long, overhead power transmission lines, induced currents due to geomagnetic disturbances during solar storms can cause saturation of the core and operation of transformer protection devices.

Distribution transformers can achieve low no-load losses by using cores made with low-loss high-permeability silicon steel or amorphous (non-crystalline) metal alloy. The higher initial cost of the core material is offset over the life of the transformer by its lower losses at light load.

Solid cores

Powdered iron cores are used in circuits such as switch-mode power supplies that operate above mains frequencies and up to a few tens of kilohertz. These materials combine high magnetic permeance with high bulk electrical resistivity. For frequencies extending beyond the VHF band, cores made from non-conductive magnetic ceramic materials called ferrites are common. Some radio-frequency transformers also have movable cores (sometimes called 'slugs') which allow adjustment of the coupling coefficient (and bandwidth) of tuned radio-frequency circuits.

Toroidal cores



Figure 2.3 Small toroidal core transformer

Toroidal transformers are built around a ring-shaped core, which, depending on operating frequency, is made from a long strip of silicon steel or perm alloy wound into a coil, powdered iron, or ferrite. A strip construction ensures that the grain boundaries are optimally aligned, improving the transformer's efficiency by reducing the core's reluctance. The closed ring shape eliminates air gaps inherent in the construction of an E-I core.^[78] The cross-section of the ring is usually square or rectangular, but more expensive cores with circular cross-sections are also available. The primary and secondary coils are often wound concentrically to cover the entire surface of the core. This minimizes the length of wire needed, and also provides screening to minimize the core's magnetic field from generating electromagnetic.

Toroidal transformers are more efficient than the cheaper laminated E-I types for a similar power level. Other advantages compared to E-I types, include smaller size (about half), lower weight (about half), less mechanical hum (making them superior in audio amplifiers), lower exterior magnetic field (about one tenth), low off-load losses (making them more efficient in standby circuits), single-bolt mounting, and greater choice of shapes. The main disadvantages are higher cost and limited power capacity (see "Classification" above). Because of the lack of a residual gap in the magnetic path, toroidal transformers also tend to exhibit higher inrush current, compared to laminated E-I types.

Ferrite toroidal cores are used at higher frequencies, typically between a few tens of kilohertz to hundreds of megahertz, to reduce losses, physical size, and weight of a switched-mode power supply. A drawback of toroidal transformer construction is the higher labor cost of winding. This is because it is necessary to pass the entire length of a coil winding through the core aperture each time a single turn is added to the coil. As a consequence, toroidal transformers are uncommon above ratings of a few kVA. Small distribution transformers may achieve some of the benefits of a toroidal core by splitting it and forcing it open, then inserting a bobbin containing primary and secondary windings.

Air cores

A physical core is not an absolute requisite and a functioning transformer can be produced simply by placing the windings near each other, an arrangement termed an "air-core" transformer. The air which comprises the magnetic circuit is essentially lossless, and so an air-core transformer eliminates loss due to hysteresis in the core material.^[41] The leakage inductance is inevitably high, resulting in very poor regulation, and so such designs are unsuitable for use in power distribution. They have

however very high bandwidth, and are frequently employed in radio-frequency applications, for which a satisfactory coupling coefficient is maintained by carefully overlapping the primary and secondary windings. They're also used for resonant transformers such as Tesla coils where they can achieve reasonably low loss in spite of the high leakage inductance.

Windings

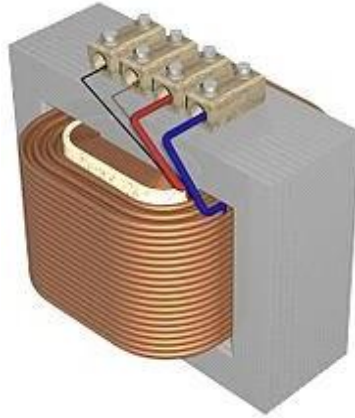

Figure 2.4 Windings are usually arranged concentrically to minimize flux leakage.

The conducting material used for the windings depends upon the application, but in all cases the individual turns must be electrically insulated from each other to ensure that the current travels throughout every turn. For small power and signal transformers, in which currents are low and the potential difference between adjacent turns are there.

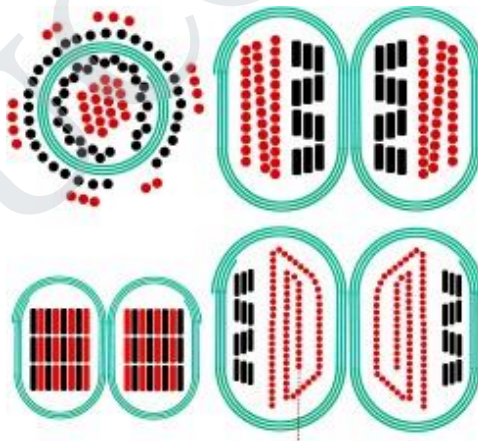

Figure 2.5 Winding shapes

Cut view through transformer windings. White: insulator. Green spiral: Grain oriented silicon steel. Black: Primary winding made of oxygen-free copper. Red: Secondary winding. Top left: Toroidal transformer. Right: C-core, but E-core would be similar. The black windings are made of film. Top: Equally low capacitance between all ends of both windings. Since most cores are at least moderately conductive they also need insulation. Bottom: Lowest capacitance for one end of the secondary winding needed for low-power high-voltage transformers. Bottom left: Reduction of leakage would lead to increase of capacitance.

Large power transformers use multiple-stranded conductors as well, since even at low power frequencies non-uniform distribution of current would otherwise exist in high-current windings. Each strand is individually insulated, and the strands are arranged so that at certain points in the winding, or throughout the whole winding, each portion occupies different relative positions in the complete conductor. The transposition equalizes the current flowing in each strand of the conductor, and reduces eddy current losses in the winding itself. The stranded conductor is also more flexible than a solid conductor of similar size, aiding manufacture.

For signal transformers, the windings may be arranged in a way to minimize leakage inductance and stray capacitance to improve high-frequency response. This can be done by splitting up each coil into sections, and those sections placed in layers between the sections of the other winding. This is known as a stacked type or interleaved winding.

Power transformers often have internal connections or taps at intermediate points on the winding, usually on the higher voltage winding side, for voltage regulation control purposes. Such taps are normally manually operated, automatic on-load tap changers being reserved, for cost and reliability considerations, to higher power rated or specialized transformers supplying transmission or distribution circuits or certain utilization loads such as furnace transformers. Audio-frequency transformers, used for the distribution of audio to public address loudspeakers, have taps to allow adjustment of impedance to each speaker. A center is often used in the output stage of an audio power amplifier in a push-pull circuit. Modulation transformers in AM transmitters are very similar. Certain transformers have the windings protected by epoxy resin. By impregnating the transformer with epoxy under a vacuum, one can replace air spaces within the windings with epoxy, thus sealing the windings and helping to prevent the possible formation of corona and absorption of dirt or water. This produces transformers more suited to damp or dirty environments, but at increased manufacturing cost.

Cooling



Figure 2.6 Cooling

Cutaway view of oil-filled power transformer. The conservator (reservoir) at top provides oil-to-atmosphere isolation. Tank walls' cooling fins provide required heat dissipation balance.

Though it is not uncommon for oil-filled transformers to have today been in operation for over fifty years high temperature damages winding insulation, the accepted rule of thumb being that transformer life expectancy is halved for every 8 degree C increase in operating temperature. At the lower end of the power rating range, dry and liquid-immersed transformers are often self-cooled by natural convection and radiation heat dissipation. As power ratings increase, transformers are often cooled by such other means as forced-air cooling, force-oil cooling, water-cooling, or a combinations of these. The dielectric coolant used in many outdoor utility and industrial service transformers is transformer oil that both cools and insulates the windings. Transformer oil is a highly refined mineral oil that inherently helps thermally stabilize winding conductor insulation, typically paper, within acceptable insulation temperature rating limitations. However, the heat removal problem is central to all electrical apparatus such that in the case of high value transformer assets, this often translates in a need to monitor, model, forecast and manage oil and winding conductor insulation temperature conditions under varying, possibly difficult, power loading conditions. Indoor liquid-filled transformers are required by building regulations in many jurisdictions to either use a non-flammable liquid or to be located in fire-resistant rooms. Air-cooled dry transformers are preferred for indoor applications even at capacity ratings where oil-cooled construction would be more economical, because their cost is offset by the reduced building construction cost.

The oil-filled tank often has radiators through which the oil circulates by natural convection. Some large transformers employ electric-operated fans or pumps for forced-air or forced-oil cooling or heat exchanger-based water-cooling. Oil-filled transformers undergo prolonged drying processes to ensure that the transformer is completely free of water before the cooling oil is introduced. This helps prevent electrical breakdown under load. Oil-filled transformers may be equipped with Buchholz relays, which detect gas evolved during internal arcing and rapidly de-energize the transformer to avert catastrophic failure. Oil-filled transformers may fail, rupture, and burn, causing power outages and losses. Installations of oil-filled transformers usually include fire protection measures such as walls, oil containment, and fire-suppression sprinkler systems.

Insulation drying

Construction of oil-filled transformers requires that the insulation covering the windings be thoroughly dried before the oil is introduced. There are several different methods of drying. Common for all is that they are carried out in vacuum environment. The vacuum makes it difficult to transfer energy (heat) to the insulation. For this there are several different methods. The traditional drying is done by circulating hot air over the active part and cycle this with periods of hot-air vacuum (HAV) drying. More common for larger transformers is to use evaporated solvent which condenses on the colder active part. The benefit is that the entire process can be carried out at lower pressure and without influence of added oxygen. This process is commonly called vapor-phase drying (VPD).

For distribution transformers, which are smaller and have a smaller insulation weight, resistance heating can be used. This is a method where current is injected in the windings to heat the insulation. The benefit is that the heating can be controlled

very well and it is energy efficient. The method is called low-frequency heating (LFH) since the current is injected at a much lower frequency than the nominal of the grid, which is normally 50 or 60 Hz. A lower frequency reduces the effect of the inductance in the transformer, so the voltage needed to induce the current can be reduced. The LFH drying method is also used for service of older transformers.

Terminals

Very small transformers will have wire leads connected directly to the ends of the coils, and brought out to the base of the unit for circuit connections. Larger transformers may have heavy bolted terminals, bus bars or high-voltage insulated bushings made of polymers or porcelain. A large bushing can be a complex structure since it must provide careful control of the electric field gradient without letting the transformer leak oil.

An ideal Transformer

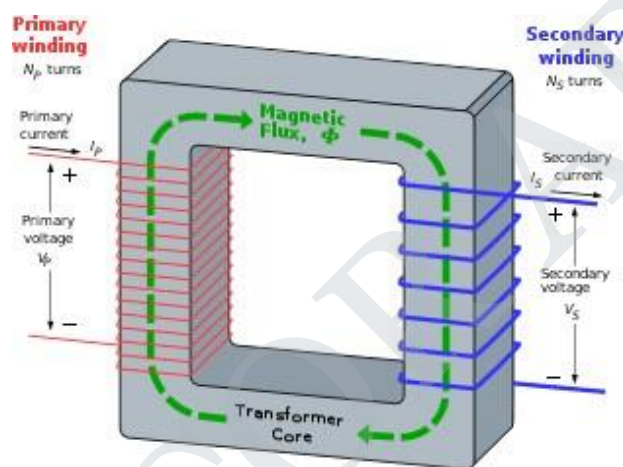

Figure 2.7 Basic principle of Operation

An ideal transformer. The secondary current arises from the action of the secondary EMF on the (not shown) load impedance. The transformer is based on two principles: first, that an electric current can produce a magnetic field (electromagnetism) and second that a changing magnetic field within a coil of wire induces a voltage across the ends of the coil (electromagnetic induction). Changing the current in the primary coil changes the magnetic flux that is developed. The changing magnetic flux induces a voltage in the secondary coil.

An ideal transformer is shown in the adjacent figure. Current passing through the primary coil creates a magnetic field. The primary and secondary coils are wrapped around a core of very high magnetic, such as iron, so that most of the magnetic flux passes through both the primary and secondary coils. If a load is connected to the secondary winding, the load current and voltage will be in the directions indicated, given the primary current and voltage in the directions indicated (each will be alternating current in practice).

Induction Law

The voltage induced across the secondary coil may be calculated from Faraday's law of induction, which states that:

$$V_s = N_s \frac{d\Phi}{dt},$$

where V_s is the instantaneous voltage, N_s is the number of turns in the secondary coil and Φ is the magnetic flux through one turn of the coil. If the turns of the coil are oriented perpendicularly to the magnetic field lines, the flux is the product of the magnetic flux density B and the area A through which it cuts. The area is constant, being equal to the cross-sectional area of the transformer core, whereas the magnetic field varies with time according to the excitation of the primary. Since the same magnetic flux passes through both the primary and secondary coils in an ideal transformer, the instantaneous voltage across the primary winding equals

$$V_p = N_p \frac{d\Phi}{dt}.$$

Taking the ratio of the two equations for V_s and V_p gives the basic equation for stepping up or stepping down the voltage

$$\frac{V_s}{V_p} = \frac{N_s}{N_p}.$$

N_p/N_s is known as the *turns ratio*, and is the primary functional characteristic of any transformer. In the case of step-up transformers, this may sometimes be stated as the reciprocal, N_s/N_p . *Turns ratio* is commonly expressed as an irreducible fraction or ratio: for example, a transformer with primary and secondary windings of, respectively, 100 and 150 turns is said to have a turns ratio of 2:3 rather than 0.667 or 100:150.

An elementary transformer consists of a soft iron or silicon steel core and two windings, placed on it. The windings are insulated from both the core and each other. The core is built up of thin soft iron or low reluctance to the magnetic flux. The winding connected to the magnetic flux. The winding connected to the supply main is called the primary and the winding connected to the load circuit is called the secondary.

Although in the actual construction the two windings are usually wound one over the other, for the sake of simplicity, the figures for analyzing transformer theory show the windings on opposite sides of the core, as shown below Simple Transformer

When primary winding is connected to an ac supply mains, current flows through it. Since this winding links with an iron core, so current flowing through this winding produces an alternating flux in the core. Since this flux is alternating and links with the secondary winding also, so induces an emf in the secondary winding.

The frequency of induced emf in secondary winding is the same as that of the flux or that of the supply voltage. The induced emf in the secondary winding enables it to deliver current to an external load connected across it. Thus the energy is transformed from primary winding to the secondary winding by means of electromagnetic induction without any change in frequency. The flux of the iron core links not only with the secondary winding but also with the primary winding, so produces self-induced emf in the primary winding:

This induced in the primary winding opposes the applied voltage and therefore sometimes it is known as back emf of the primary. In fact the induced emf in the primary winding limits the primary current in much the same way that the back emf in a dc motor limits the armature current.

Transformation ratio.

The ratio of secondary voltage to primary voltage is known as the voltage transformation ratio and is designated by letter K. i.e. Voltage transformation ratio.

Current ratio.

The ratio of secondary current to primary current is known as current ratio and is reciprocal of voltage transformation ratio in an ideal transformer.

Equivalent Circuit

The electrical circuit for any electrical engineering device can be drawn if the equations describing its behavior are known. The equivalent circuit for electromagnetic device is a combination of resistances, inductances, capacitances, voltages etc. In the equivalent circuit, (R_1+jX_1) and (R_2+jX_2) are the leakage impedances of the primary and secondary windings respectively. The primary current I_1 consists of two components. One component, I_1' is the load component and the second is no-load current I_0 which is composed of I_c and I_m . The current I_c is in phase with E_1 and the product of these two gives core loss. R_0 represents the core loss and is called core-loss resistance. The current I_m is represented by a reactance X_0 and is called magnetizing reactance. The transformer magnetization curve is assumed linear, since the effect of higher order harmonics can't be represented in the equivalent circuit. In transformer analysis, it is usual to transfer these secondary quantities to primary side or primary quantities to secondary side.

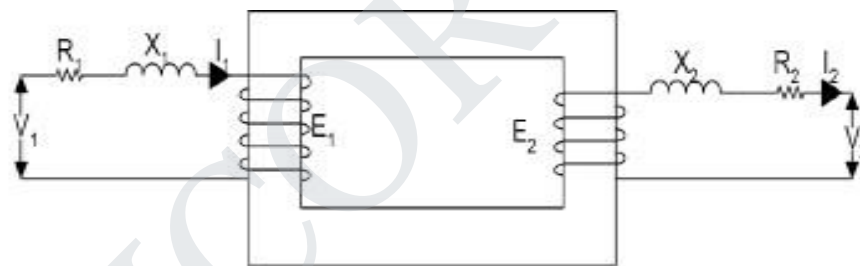

(a) Exciting current neglected

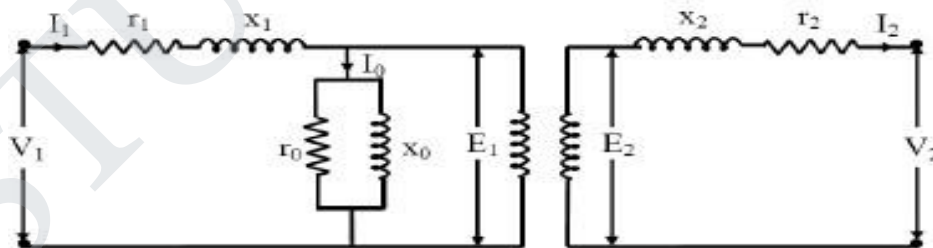

(b) Exact equivalent circuit

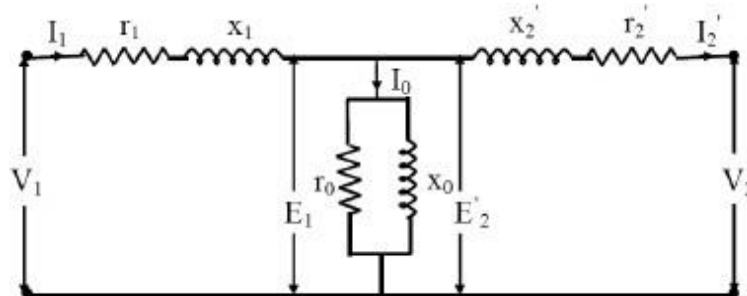

(c) Equivalent circuit in general form

Figure 2.8 Equivalent Circuit

Transformer Losses

1. Primary copper loss
2. Secondary copper loss
3. Iron loss
4. Dielectric loss
5. Stray load loss

These are explained in sequence below.

Primary and secondary copper losses take place in the respective winding resistances due to the flow of the current in them. The primary and secondary resistances differ from their d.c. values due to skin effect and the temperature rise of the windings. While the average temperature rise can be approximately used, the skin effect is harder to get analytically. The short circuit test gives the value of R_e taking into account the skin effect.

The iron losses contain two components - Hysteresis loss and Eddy current loss. The Hysteresis loss is a function of the material used for the core. $P_h = K_h B^{1.6} f$. For constant voltage and constant frequency operation this can be taken to be constant. The eddy current loss in the core arises because of the induced emf in the steel lamination sheets and the eddies of current formed due to it. This again produces a power loss P_e in the lamination, where t is the thickness of the steel lamination used. As the lamination thickness is much smaller than the depth of penetration of the field, the eddy current loss can be reduced by reducing the thickness of the lamination. Present day laminations are of 0.25 mm thickness and are capable of operation at 2 Tesla.

These reduce the eddy current losses in the core. This loss also remains constant due to constant voltage and frequency of operation. The sum of hysteresis and eddy current losses can be obtained by the open circuit test. The dielectric losses take place in the insulation of the transformer due to the large electric stress. In the case of low voltage transformers this can be neglected. For constant voltage operation this can be assumed to be a constant. The stray load losses arise out of the leakage fluxes of the transformer. These leakage fluxes link the metallic structural parts, tank etc. and produce eddy current losses in them. Thus they take place 'all round' the transformer instead of a definite place, hence the name 'stray'. Also the leakage flux is directly proportional to the load current unlike the mutual flux which is proportional to the applied voltage. Hence this loss is called 'stray load' loss. This can also be estimated experimentally.

It can be modeled by another resistance in the series branch in the equivalent circuit. The stray load losses are very low in air-cored transformers due to the absence of the metallic tank. Thus, the different losses fall in to two categories Constant losses (mainly voltage dependant) and Variable losses (current dependant). The expression for the efficiency of the transformer operating at a fractional load x of its rating, at a load power factor of $\cos \phi$, can be written as losses and P_{var} the variable losses at full load. For a given power factor an expression for η in terms of the variable x is thus obtained. By differentiating with respect to x and equating the same to zero, the condition for maximum efficiency is obtained. The maximum efficiency it can be easily deduced that this maximum value increases with increase in power factor and is zero at zero power factor of the load. It may be considered a good practice to select the operating load point to be at the maximum efficiency point. Thus if a transformer is on

full load, for most part of the time then the max can be made to occur at full load by proper selection of constant and variable losses. However, in the modern transformers the iron losses are so low that it is practically impossible to reduce the full load copper losses to that value. Such a design wastes lot of copper. This point is illustrated with the help of an example below. Two 100 kVA transformers A and B are taken. Both transformers have total full load losses to be 2 kW. The break up of this loss is chosen to be different for the two transformers. Transformer A: iron loss 1 kW, and copper loss is 1 kW. The maximum efficiency of 98.04% occurs at full load at unity power factor. Transformer B: Iron loss = 0.3 kW and full load copper loss = 1.7 kW. This also has a full load of 98.04%. Its maximum occurs at a fractional load of $q = 0.317 = 0.42$. The maximum efficiency at unity power factor being at the corresponding point the transformer A has an efficiency of Transformer A uses iron of more loss per kg at a given flux density, but transformer B uses lesser quantity of copper and works at higher current density.

When the primary of a transformer is connected to the source of an ac supply and the secondary is open circuited, the transformer is said to be on no load. Which will create alternating flux. No-load current, also known as excitation or exciting current has two components the magnetizing component I_m and the energy component I_e .

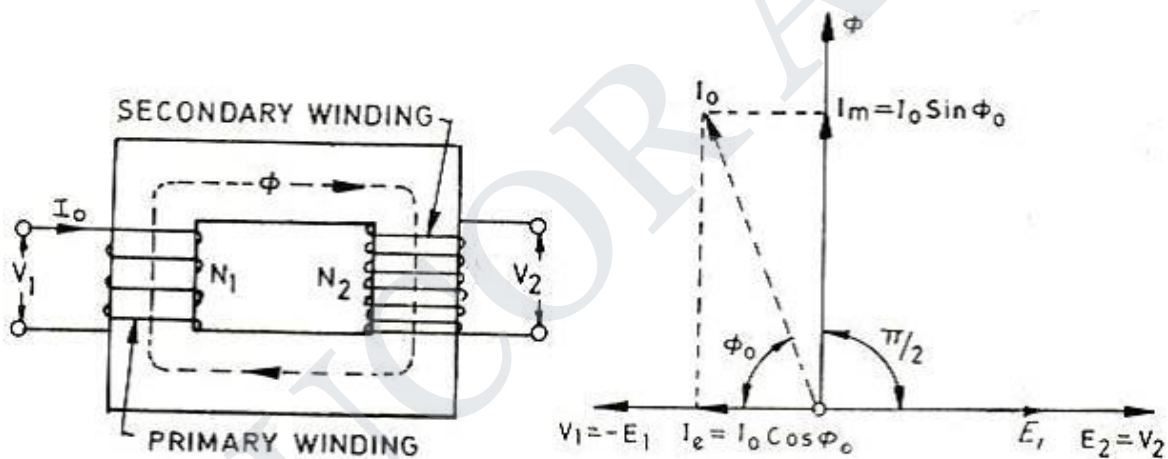

Figure 2.9 Transformer on No Load

I_m is used to create the flux in the core and I_e is used to overcome the hysteresis and eddy current losses occurring in the core in addition to small amount of copper losses occurring in the primary only (no copper loss occurs in the secondary, because it carries no current, being open circuited.) From vector diagram shown in above it is obvious that

1. Induced emfs in primary and secondary windings, and lag the main flux by and are in phase with each other.
2. Applied voltage to primary and leads the main flux by and is in phase opposition to .
3. Secondary voltage is in phase and equal to since there is no voltage drop in secondary.
4. is in phase with and so lags
5. is in phase with the applied voltage .
6. Input power on no load = \cos where

Transformer on Load

The transformer is said to be loaded, when its secondary circuit is completed through an impedance or load. The magnitude and phase of secondary current (i.e. current flowing through secondary) with respect to secondary terminals depends upon the characteristic of the load i.e. current will be in phase, lag behind and lead the terminal voltage respectively when the load is non-inductive, inductive and capacitive. The net flux passing through the core remains almost constant from no-load to full load irrespective of load conditions and so core losses remain almost constant from no-load to full load.

Secondary windings Resistance and Leakage Reactance In actual practice, both of the primary and secondary windings have got some ohmic resistance causing voltage drops and copper losses in the windings. In actual practice, the total flux created does not link both of the primary and secondary windings but is divided into three components namely the main or mutual flux linking both of the primary and secondary windings, primary leakage flux linking with primary winding only and secondary leakage flux linking with secondary winding only.

The primary leakage flux is produced by primary ampere-turns and is proportional to primary current, number of primary turns being fixed. The primary leakage flux is in phase with and produces self induced emf E given as $2f$ in the primary winding. The self induced emf divided by the primary current gives the reactance of primary and is denoted by .

$$\text{i.e. } E = 2f\pi$$

Transformer Tests

1 .Open-circuit or no-load test

2.Short circuit or impedance test

Open-circuit or No-load Test.

In this test secondary (usually high voltage) winding is left open, all metering instruments (ammeter, voltmeter and wattmeter) are connected on primary side and normal rated voltage is applied to the primary (low voltage) winding, as illustrated below

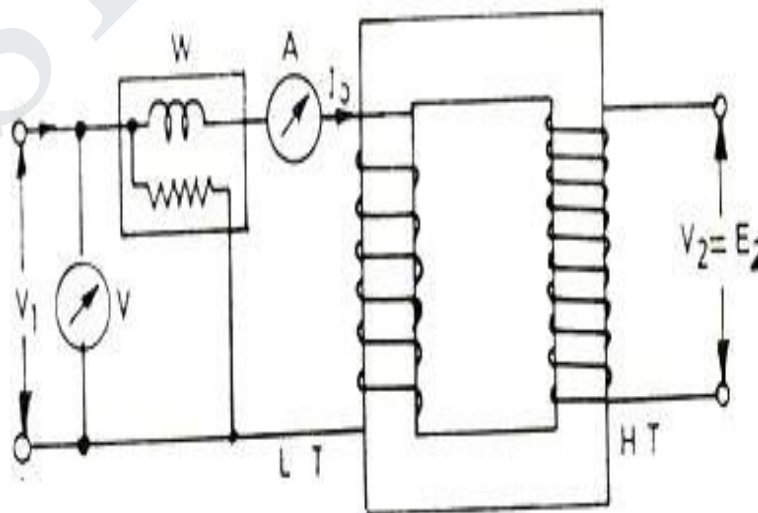

Figure 2.10 Open Circuit

Iron loss = Input power on no-load W_0 watts (wattmeter reading) No-load current = I_0 amperes (ammeter reading) Angle of lag, $\phi = \cos^{-1} \frac{W_0}{V_0 I_0}$ and $I_m = I_0 \sin \phi$ - Caution: Since no load current I_0 is very small, therefore, pressure coils of watt meter and the volt meter should be connected such that the current taken by them should not flow through the current taken by them should not flow through the current coil of the watt meter.

Short-circuit or Impedance Test.

This test is performed to determine the full-load copper loss and equivalent resistance and reactance referred to secondary side. In this test, the terminals of the secondary (usually the low voltage) winding are short circuited, all meters (ammeter, voltmeter and wattmeter) are connected on primary side and a low voltage, usually 5 to 10 % of normal rated primary voltage at normal frequency is applied to the primary, as shown in fig below.

The applied voltage to the primary, say V_s' is gradually increased till the ammeter A indicates the full load current of the side in which it is connected. The reading W_s of the wattmeter gives total copper loss (iron losses being negligible due to very low applied voltage resulting in very small flux linking with the core) at full load. Let the ammeter reading be I_s .

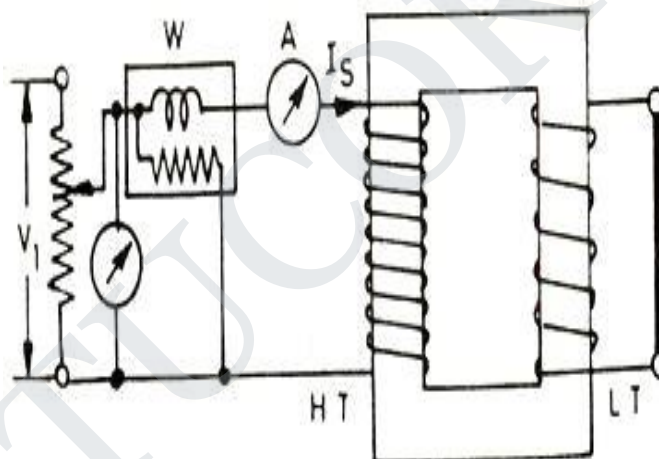
**Figure 2.11 Short Circuit**

Equivalent impedance referred to primary = Commercial Efficiency and All-day Efficiency (a) Commercial Efficiency. Commercial efficiency is defined as the ratio of power output to power input in kilowatts. (b) All-day Efficiency. The all-day efficiency is defined as the ratio of output in kwh to the input in kwh during the whole day. Transformers used for distribution are connected for the whole day to the line but loaded intermittently. Thus the core losses occur for the whole day but copper losses occur only when the transformer is delivering the load current. Hence if the transformer is not used to supply the load current for the whole day all-day efficiency will be less than commercial efficiency. The efficiency (commercial efficiency) will be maximum when variable losses (copper losses) are equal to constant losses (iron or core losses). sign is for inductive load and sign is for capacitive load Transformer

efficiency, Where x is the ratio of secondary current I_2 and rated full load secondary current.

Efficiency

Transformers which are connected to the power supplies and loads and are in operation are required to handle load current and power as per the requirements of the load. An unloaded transformer draws only the magnetization current on the primary side, the secondary current being zero. As the load is increased the primary and secondary currents increase as per the load requirements. The volt amperes and wattage handled by the transformer also increases. Due to the presence of no load losses and I^2R losses in the windings certain amount of electrical energy gets dissipated as heat inside the transformer.

This gives rise to the concept of efficiency. Efficiency of a power equipment is defined at any load as the ratio of the power output to the power input. Putting in the form of an expression, while the efficiency tells us the fraction of the input power delivered to the load, the deficiency focuses our attention on losses taking place inside transformer. As a matter of fact the losses heat up machine. The temperature rise decides the rating of the equipment. The temperature rise of the machine is a function of heat generated the structural configuration, method of cooling and type of loading (or duty cycle of load). The peak temperature attained directly affects the life of the insulations of the machine for any class of insulation.

These aspects are briefly mentioned under section load test. The losses that take place inside the machine expressed as a fraction of the input is sometimes termed as deficiency. Except in the case of an ideal machine, a certain fraction of the input power gets lost inside the machine while handling the power. Thus the value for the efficiency is always less than one. In the case of a.c. machines the rating is expressed in terms of apparent power. It is nothing but the product of the applied voltage and the current drawn. The actual power delivered is a function of the power factor at which this current is drawn.

As the reactive power shuttles between the source and the load and has a zero average value over a cycle of the supply wave it does not have any direct effect on the efficiency. The reactive power however increases the current handled by the machine and the losses resulting from it. Therefore the losses that take place inside a transformer at any given load play a vital role in determining the efficiency. The losses taking place inside a transformer can be enumerated as below:

1. Primary copper loss
2. Secondary copper loss
3. Iron loss
4. Dielectric loss
5. Stray load loss

These are explained in sequence below.

Primary and secondary copper losses take place in the respective winding resistances due to the flow of the current in them. The primary and secondary resistances differ from their d.c. values due to skin effect and the temperature rise of the windings. While the average temperature rise can be approximately used, the skin effect is harder to get analytically. The short circuit test gives the value of R_e taking into account the skin effect. The iron losses contain two components Hysteresis loss

and Eddy current loss. The Hysteresis loss is a function of the material used for the core. $P_h = K_h B^{1.6} f$ For constant voltage and constant frequency operation this can be taken to be constant. The eddy current loss in the core arises because of the induced emf in the steel lamination sheets and the eddies of current formed due to it. This again produces a power loss P_e in the lamination. Where t is the thickness of the steel lamination used. As the lamination thickness is much smaller than the depth of penetration of the field, the eddy current loss can be reduced by reducing the thickness of the lamination. Present day laminations are of 0.25 mm thickness and are capable of operation at 2 Tesla.

These reduce the eddy current losses in the core. This loss also remains constant due to constant voltage and frequency of operation. The sum of hysteresis and eddy current losses can be obtained by the open circuit test. The dielectric losses take place in the insulation of the transformer due to the large electric stress. In the case of low voltage transformers this can be neglected. For constant voltage operation this can be assumed to be a constant. The stray load losses arise out of the leakage fluxes of the transformer. These leakage fluxes link the metallic structural parts, tank etc. and produce eddy current losses in them. Thus they take place 'all round' the transformer instead of a definite place, hence the name 'stray'. Also the leakage flux is directly proportional to the load current unlike the mutual flux which is proportional to the applied voltage.

Hence this loss is called 'stray load' loss. This can also be estimated experimentally. It can be modeled by another resistance in the series branch in the equivalent circuit. The stray load losses are very low in air-cored transformers due to the absence of the metallic tank. Thus, the different losses fall in to two categories Constant losses (mainly voltage dependant) and Variable losses (current dependant). The expression for the efficiency of the transformer operating at a fractional load x of its rating, at a load power factor of $\cos \phi$ can be written as losses and P_{var} the variable losses at full load. For a given power factor an expression for η in terms of the variable x is thus obtained. By differentiating η with respect to x and equating the same to zero, the condition for maximum efficiency is obtained. The maximum efficiency it can be easily deduced that this Maximum value increases with increase in power factor and is zero at zero power factor of the load. It may be considered a good practice to select the operating load point to be at the maximum efficiency point.

Thus if a transformer is on full load, for most part of the time then the max can be made to occur at full load by proper selection of constant and variable losses. However, in the modern transformers the iron losses are so low that it is practically impossible to reduce the full load copper losses to that value. Such a design wastes lot of copper. This point is illustrated with the help of an example below. Two 100 kVA transformers A and B are taken. Both transformers have total full load losses to be 2 kW. The breakup of this loss is chosen to be different for the two transformers. Transformer A: iron loss 1 kW, and copper loss is 1 kW. The maximum efficiency of 98.04% occurs at full load at unity power factor. Transformer B: Iron loss = 0.3 kW and full load copper loss = 1.7 kW. This also has a full load efficiency of 98.04%. Its maximum occurs at a fractional load of $\sqrt{0.3/1.7} = 0.42$. The maximum efficiency at unity power factor being at the corresponding point the transformer A has an efficiency of Transformer A uses iron of more loss per kg at a given flux density, but transformer B uses lesser quantity of copper and works at higher current density.

$$\% \text{ Efficiency} = \frac{W_{out}}{W_{in}} \times 100$$

All day efficiency

Large capacity transformers used in power systems are classified broadly into Power transformers and Distribution transformers. The former variety is seen in generating stations and large substations. Distribution transformers are seen at the distribution substations. The basic difference between the two types arises from the fact that the power transformers are switched in or out of the circuit depending upon the load to be handled by them. Thus at 50% load on the station only 50% of the transformers need to be connected in the circuit. On the other hand a distribution transformer is never switched off. It has to remain in the circuit irrespective of the load connected. In such cases the constant loss of the transformer continues to be dissipated. Hence the concept of energy based efficiency is defined for such transformers. It is called 'all day' efficiency. The all day efficiency is thus the ratio of the energy output of the transformer over a day to the corresponding energy input. One day is taken as duration of time over which the load pattern repeats itself. This assumption, however, is far from being true. The power output varies from zero to full load depending on the requirement of the user and the load losses vary as the square of the fractional loads. The no-load losses or constant losses occur throughout the 24 hours. Thus, the comparison of loads on different days becomes difficult. Even the load factor, which is given by the ratio of the average load to rated load, does not give satisfactory results. The calculation of the all day efficiency is illustrated below with an example. The graph of load on the transformer, expressed as a fraction of the full load is plotted against time. In an actual situation the load on the transformer continuously changes. This has been presented by a stepped curve for convenience. For the same load factor different average loss can be there depending upon the values of x_i and t_i . Hence a better option would be to keep the constant losses very low to keep the all day efficiency high. Variable losses are related to load and are associated with revenue earned. The constant loss on the other hand has to be incurred to make the service available. The concept of all day efficiency may therefore be more useful for comparing two transformers subjected to the same load cycle. The concept of minimizing the lost energy comes into effect right from the time of procurement of the transformer. The constant losses and variable losses are capitalized and added to the material cost of the transformer in order to select the most competitive one, which gives minimum cost taking initial cost and running cost put together. Obviously the iron losses are capitalized more in the process to give an effect to the maximization of energy efficiency. If the load cycle is known at this stage, it can also be incorporated in computation of the best transformer.

Voltage Regulation

With the increase in load on the transformer, there is a change in its terminal voltage. The voltage falls if the load power factor is lagging. It increases if power is leading. The change in secondary terminal voltage from full load to no load, expressed as a percentage of full load voltage is called the percentage voltage regulation of the transformer

% Regulation = $\frac{V - V_L}{V} \times 100$.

Circuit Diagram

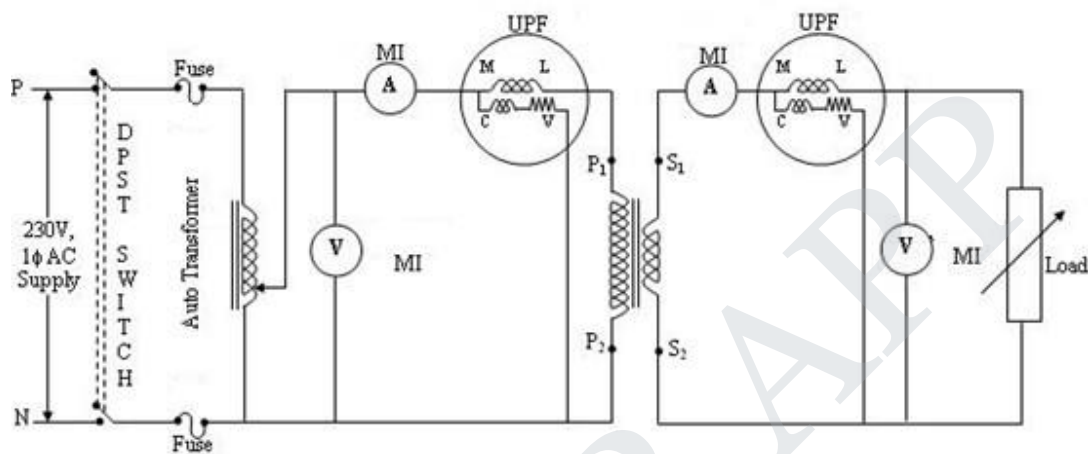

Figure 2.2 Load Test

Procedure:

- Connect the circuit diagram as shown in fig (a)
- Apply full load and note down the readings of wattmeter, voltmeter and ammeter.
- Decrease the load and note down the readings.
- Calculate efficiency and regulation.

Observation Table

W ₁	V ₁	I ₂	η

Calculation

$$\eta = V_2 I_2 / W_1 * 100$$

$$\% \text{ Reg} = (E - V) * 100 / V$$

Discussion

By calculating the voltage regulation the figure of merit which determines the voltage characteristics of a transformer can be determined. Also the transformer efficiency can't be determined with high precision since the losses are of order of only 1 to 4%. The best and accurate method of determining the efficiency of a transformer would be to compute losses from open circuit and short circuit test and then determine the efficiency.

Auto Transformer

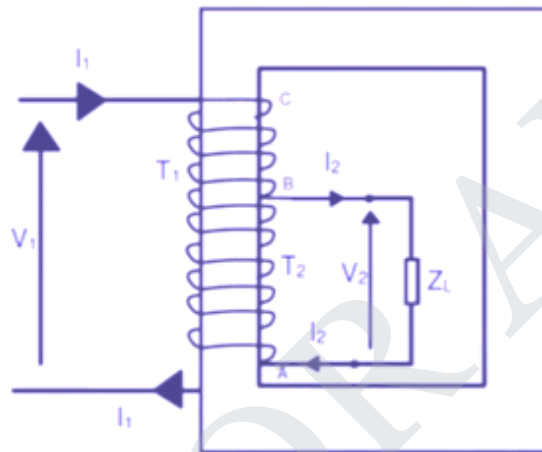

Figure 2.13 Autotransformer - Physical Arrangement

The primary and secondary windings of a two winding transformer have induced emf in them due to a common mutual flux and hence are in phase. The currents drawn by these two windings are out of phase by 180° . This prompted the use of a part of the primary as secondary. This is equivalent to fusing the secondary turns into primary turns. The fused section need to have a cross sectional area of the conductor to carry $(I_2 - I_1)$ ampere! This ingenious thought led to the invention of an auto transformer. Fig. 28 shows the physical arrangement of an auto transformer. Total number of turns between A and C are T_1 . At point B a connection is taken. Section AB has T_2 turns. As the volts per turn, which is proportional to the flux in the machine, is the same for the whole winding,

$$V_1 : V_2 = T_1 : T_2 \quad (76)$$

For simplifying analysis, the magnetizing current of the transformer is neglected.

When the secondary winding delivers a load current of I_2 ampere the demagnetizing ampere turns is $I_2 T_2$. This will be countered by a current I_1 flowing from the source through the T_1 turns such that,

$$I_1 T_1 = I_2 T_2 \quad (77)$$

A current of I_1 ampere flows through the winding between B and C. The current in the winding between A and B is $(I_2 - I_1)$ ampere. The cross section of the wire to be selected for AB is proportional to this current assuming a constant current density for the whole winding. Thus some amount of material saving can be achieved compared to a two winding transformer. The magnetic circuit is assumed to be identical and hence there is no saving in the same. To quantify the saving the total quantity of

copper used in an auto transformer is expressed as a fraction of that used in a two winding transformer as,

$$\frac{\text{copper in auto transformer}}{\text{copper in two winding transformer}} = \frac{(T_1 - T_2)I_1 + T_2(I_2 - I_1)}{T_1I_1 + T_2I_2}$$

$$= 1 - \frac{2T_2I_1}{T_1I_1 + T_2I_2}$$

But $T_1I_1 = T_2I_2$

$$\therefore \text{The Ratio} = 1 - \frac{2T_2I_1}{2T_1I_1} = 1 - \frac{T_2}{T_1}$$

This means that an auto transformer requires the use of lesser quantity of copper given by the ratio of turns. This ratio therefore denotes the savings in copper. As the space for the second winding need not be there, the window space can be less for an auto transformer, giving some saving in the lamination weight also. The larger the ratio of the voltages, smaller is the savings. As T_2 approaches T_1 the savings become significant. Thus auto transformers become ideal choice for close ratio transformations. The savings in material is obtained, however, at a price. The electrical isolation between primary and secondary

Three-phase autotransformer connection

Design, Vector group

A three-phase transformer consists of the interconnection of three single-phase transformers in Y- or D - connection. This transformer connects two three-phase systems of different voltages (according to the voltage ratio). This arrangement is mainly used in the USA – in Europe only for high power applications (>200 MVA) because of transportation problems. The combination in one single three-phase unit instead of three single-phase units is usual elsewhere. The technical implementation is very simple. Three single-phase transformers, connected to three phase systems on primary and secondary side, are to be spatially arranged. A complete cycle of the measuring loop around the three iron cores results in $= 0$ i u and:

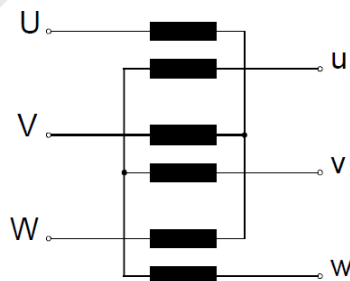

Figure 2.14 Three-phase assembly

Three-Leg Transformer

The magnetic return paths of the three cores can be dropped, which results in the usual type of three-phase transformers.

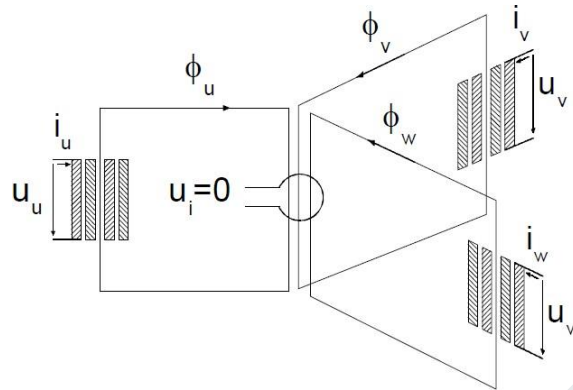

Figure2.15 Spatial arrangement

One primary and one secondary winding of a phase is arranged on any leg Five-leg transformers are used for high power applications (low overall height).

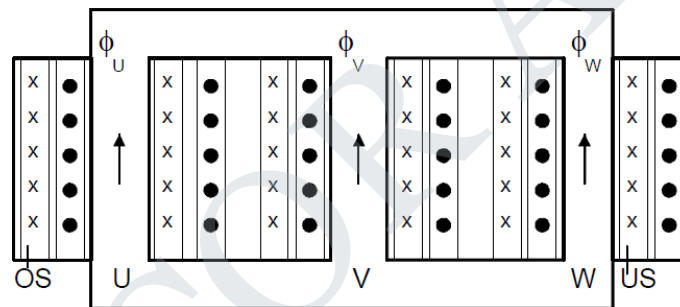

Figure2.16 Three-leg transformer

Primary and secondary winding can be connected in Y- or \square - connection, according to

Requirements. The additional opportunity of a so called zigzag connection can be used on the secondary side. The separation of the windings into two parts and their application on two different cores characterize this type of connection. This wiring is particularly suitable for single-phase loads. Significant disadvantage is the additional copper expense on thesecondary side increased about a factor $2/3$ compared to Y- or D - connection. A conversion from line-to-line quantities to phase quantities and the usage of single-phase ecdand phasor diagram is reasonable for the calculation of the operational behavior of balanced loaded three-phase transformers.

The method of symmetrical components (see 2.6) is suited for calculations in case of unbalanced load conditions. In a parallel connection of two three-phase transformers the transformation ratio as well as the phase angle multiplier of the according vector group needs to be adapted.

Examples for vector groups (based on VDE regulations):

phase angle multiplier	vector group	phasor diagram		ecd		ratio
		primary side	secondary side	primary side	secondary side	
0	Yy0					$\frac{w_1}{w_2}$
6	Yy6					$\frac{w_1}{w_2}$
5	Yd5					$\frac{\sqrt{3}w_1}{w_2}$
	Yz5					$\frac{2w_1}{\sqrt{3}w_2}$

Figure 2.17 Table showing phasor diagrams and ecd according to vector group and multiplier

With:

- upper case letter → vector group on primary side
- lower case letter → vector group on secondary side
- Y, y → star connection
- D, d → delta connection (?)
- z → zigzag connection

The multiplier gives the number of multiples of 30°, defining the total phase shift, of which the low voltage (secondary side) lags behind the higher voltage (same orientation of reference arrow assumed).

Mnemonic: clock

- higher voltage: 12 o'clock
- lower voltage: number of multiplier (on the clock)

Parallel Operation Of Transformers

By parallel operation we mean two or more transformers are connected to the same supply bus bars on the primary side and to a common bus bar/load on the secondary side. Such requirement is frequently encountered in practice. The reasons that necessitate parallel operation are as follows.

1. Non-availability of a single large transformer to meet the total load requirement.
2. The power demand might have increased over a time necessitating augmentation of the capacity. More transformers connected in parallel will then be pressed into service.

3. To ensure improved reliability. Even if one of the transformers gets into a fault or is taken out for maintenance/repair the load can continued to be serviced.
4. To reduce the spare capacity. If many smaller size transformers are used one machine can be used as spare. If only one large machine is feeding the load, a spare of similar rating has to be available. The problem of spares becomes more acute with fewer machines in service at a location.
5. When transportation problems limit installation of large transformers at site, it may be easier to transport smaller ones to site and work them in parallel. Fig. 37 shows the physical arrangement of two single phase transformers working in parallel on the primary side. Transformer A and Transformer B are connected to input voltage bus bars. After ascertaining the polarities they are connected to output/load bus bars. Certain conditions have to be met before two or more transformers are connected in parallel and share a common load satisfactorily. They are,
 1. The voltage ratio must be the same.
 2. The per unit impedance of each machine on its own base must be the same.
 3. The polarity must be the same, so that there is no circulating current between the transformers.
 4. The phase sequence must be the same and no phase difference must exist between the voltages of the two transformers.

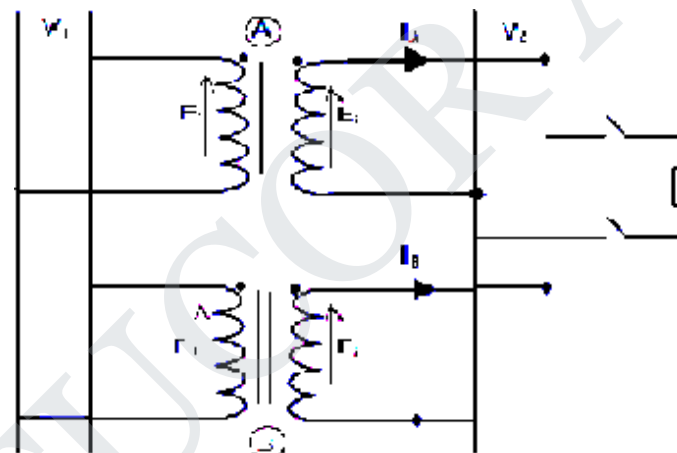

Figure 2.18 PARALLEL OPERATION OF TRANSFORMERS

Where,

V_1 =Load bus voltage

V_2 =Supply voltage

These conditions are examined first with reference to single phase transformers and then the three phase cases are discussed. Same voltage ratio generally the turns ratio and voltage ratio are taken to be the same. If the ratio is large there can be considerable error in the voltages even if the turns ratios are the same. When the primaries are connected to same bus bars, if the secondaries do not show the same voltage, paralleling them would result in a circulating current between the secondaries. Reflected circulating current will be there on the primary side also. Thus even without connecting a load considerable current can be drawn by the transformers and they produce copper losses. In two identical transformers with percentage impedance of 5 percent, a no-load voltage difference of one percent will result in a circulating current of 10 percent of full load current. This circulating current gets added to the load current when the load is connected resulting in unequal sharing of the load. In such

cases the combined full load of the two transformers can never be met without one transformer getting overloaded.

Per unit impedance Transformers of different ratings may be required to operate in parallel. If they have to share the total load in proportion to their ratings the larger machine has to draw more current. The voltage drop across each machine has to be the same by virtue of their connection at the input and the output ends. Thus the larger machines have smaller impedance and smaller machines must have larger ohmic impedance. Thus the impedances must be in the inverse ratios of the ratings. As the voltage drops must be the same the per unit impedance of each transformer on its own base, must be equal. In addition if active and reactive powers are required to be shared in proportion to the ratings the impedance angles also must be the same. Thus we have the requirement that per unit resistance and per unit reactance of both the transformers must be the same for proper load sharing. Polarity of connection The polarity of connection in the case of single phase transformers can be either same or opposite. Inside the loop formed by the two secondaries the resulting voltage must be zero.

If wrong polarity is chosen the two voltages get added and short circuit results. In the case of polyphase banks it is possible to have permanent phase error between the phases with substantial circulating current. Such transformer banks must not be connected in parallel. The turn's ratios in such groups can be adjusted to give very close voltage ratios but phase errors cannot be compensated. Phase error of 0.6 degree gives rise to one percent difference in voltage. Hence poly phase transformers belonging to the same vector group alone must be taken for paralleling. Transformers having -30° angle can be paralleled to that having $+30^\circ$ angle by reversing the phase sequence of both primary and secondary terminals of one of the transformers.

This way one can overcome the problem of the phase angle error. Phase sequence the phase sequence of operation becomes relevant only in the case of poly phase systems. The poly phase banks belonging to same vector group can be connected in parallel. A transformer with $+30^\circ$ phase angle however can be paralleled with the one with -30° phase angle; the phase sequence is reversed for one of them both at primary and secondary terminals. If the phase sequences are not the same then the two transformers cannot be connected in parallel even if they belong to same vector group.

The phase sequence can be found out by the use of a phase sequence indicator. Performance of two or more single phase transformers working in parallel can be computed using their equivalent circuit. In the case of poly phase banks also the approach is identical and the single phase equivalent circuit of the same can be used. Basically two cases arise in these problems. Case A: when the voltage ratio of the two transformers is the same and Case B: when the voltage ratios are not the same. These are discussed now in sequence.

Tap Changing

Regulating the voltage of a transformer is a requirement that often arises in a power application or power system. In an application it may be needed

1. To supply a desired voltage to the load.
2. To counter the voltage drops due to loads.
3. To counter the input supply voltage changes on load.

On a power system the transformers are additionally required to perform the task of regulation of active and reactive power flows.

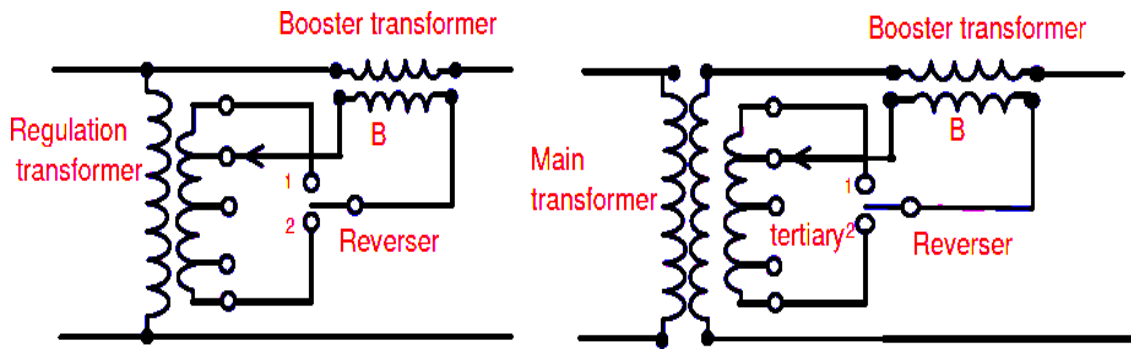

Figure 19 Tap changing and Buck Boost arrangement

The voltage control is performed by changing the turns ratio. This is done by provision of taps in the winding. The volts per turn available in large transformers is quite high and hence a change of even one turn on the LV side represents a large percentage change in the voltage. Also the LV currents are normally too large to take out the tapping from the windings. LV winding being the inner winding in a core type transformer adds to the difficulty of taking out of the taps. Hence irrespective of the end use for which tapping is put to, taps are provided on the HV winding. Provision of taps to control voltage is called tap changing. In the case of power systems, voltage levels are sometimes changed by injecting a suitable voltage in series with the line.

This may be called buck-boost arrangement. In addition to the magnitude, phase of the injected voltage may be varied in power systems. The tap changing arrangement and buck boost arrangement with phase shift are shown in Fig. 42. Tap changing can be effected when a) the transformer is on no-load and b) the load is still remains connected to the transformer. These are called off load tap changing and on load tap changing. The Off load taps changing relatively costs less. The tap positions are changed when the transformer is taken out of the circuit and reconnected. The on-load tap changer on the other hand tries to change the taps without the interruption of the load current.

In view of this requirement it normally costs more. A few schemes of on-load tap changing are now discussed. Reactor method The diagram of connections is shown in Fig. 43. This method employs an auxiliary reactor to assist tap changing. The switches for the taps and that across the reactor(S) are connected as shown. The reactor has a center tapped winding on a magnetic core. The two ends of the reactor are connected to the two bus bars to which tapping switches of odd/even numbered taps are connected. When only one tap is connected to the reactor the shorting switch S is closed minimizing the drop in the reactor. The reactor can also be worked with both ends connected to two successive taps. In that case the switch 'S' must be kept open. The reactor limits the circulating current between the taps in such a situation. Thus a four step tapped winding can be used for getting seven step voltage on the secondary(see the table of switching).

Taps	Switches closed
1	1,S
2	1,2
3	2,S
4	2,3
5	3,S
6	3,4
7	4,S
8	4,5

9	5,S
---	-----

Reactor method the diagram of connections is shown in Fig. 43. This method employs an auxiliary reactor to assist tap changing. The switches for the taps and that across the reactor(S) are connected as shown. The reactor has a center tapped winding on a magnetic core. The two ends of the reactor are connected to the two bus bars to which tapping switches of odd/even numbered taps are connected. When only one tap is connected to the reactor the shorting switch S is closed minimizing the drop in the reactor. The reactor can also be worked with both ends connected to two successive taps. In that case the switch 'S' must be kept open. The reactor limits the circulating current between the taps in such a situation. Thus a four step tapped winding can be used for getting seven step voltage on the secondary (see the table of switching). The advantage of this type of tap changer is

1. Load need not be switched.
2. More steps than taps are obtained.
3. Switches need not interrupt load current as a alternate path is always provided.

The major objection to this scheme seems to be that the reactor is in the circuit always generating extra loss. Parallel winding, transformer method In order to maintain the continuity of supply the primary winding is split into two parallel circuits each circuit having the taps. as

Two circuit breakers A and B are used in the two circuits. Initially tap 1a and 1b are closed and the transformer is energized with full primary voltage. To change the tap the circuit breaker A is opened momentarily and tap is moved from 1a to 2a. Then circuit breaker A is closed. When the circuit A is opened whole of the primary current of the transformer flows through the circuit B. A small difference in the number of turns between the two circuit exists. This produces a circulating current between them. Next, circuit breaker B is opened momentarily, the tap is changed from 1b to 2b and the breaker is closed. In this position the two circuits are similar and there is no circulating current. The circulating current is controlled by careful selection of the leakage reactance.

Generally, parallel circuits are needed in primary and secondary to carry the large current in a big transformer. Provision of taps switches and circuit breakers are to be additionally provided to achieve tap changing in these machines. Series booster method in this case a separate transformer is used to buck/boost the voltage of the main transformer. The main transformer need not be having a tapped arrangement. This arrangement can be added to an existing system also. It shows the booster arrangement for a single phase supply. The reverser switch reverses the polarity of the injected voltage and hence a boost is converted into a buck and vice versa. The power rating of this transformer need be a small fraction of the main transformer as it is required to handle only the power associated with the injected voltage.

The advantage of this type of tap changer are The major objection to this scheme seems to be that the reactor is in the circuit always generating extra loss. Parallel winding, transformer method In order to maintain the continuity of supply the primary winding is split into two parallel circuits each circuit having the taps. Two circuit breakers A and B are used in the two circuits. Initially tap 1a and 1b are closed and the transformer is energized with full primary voltage. To change the tap the circuit breaker A is opened momentarily and tap is moved from 1a to 2a. Then circuit breaker A is closed. When the circuit A is opened whole of the primary current of the transformer flows through the circuit B. A small difference in the number of turns between the two circuits exists. This produces a circulating current between them. Next, circuit breaker B is opened momentarily, the tap is changed from 1b to 2b and

the breaker is closed. In this position the two circuits are similar and there is no circulating current. The circulating current is controlled by careful selection of the leakage reactance. Generally, parallel circuits are needed in primary and secondary to carry the large current in a big transformer. Provision of taps switches and circuit breakers are to be additionally provided to achieve tap changing in these machines. Series booster method in this case a separate transformer is used to buck/boost the voltage of the main transformer. The main transformer need not be having a tapped arrangement.

This arrangement can be added to an existing system also. It shows the booster arrangement for a single phase supply. The reverser switch reverses the polarity of the injected voltage and hence a boost is converted into a buck and vice versa. The power rating of this transformer need be a small fraction of the main transformer as it is required to handle only the power associated with the injected voltage. One precaution to be taken with this arrangement is that the winding must output side. In smaller ratings this is highly cost effective. Two winding arrangements are also possible. The two winding arrangement provides electrical isolation. Not be open circuited. If it gets open circuited the core (B in fig) gets highly saturated.

In spite of the small ratings and low voltages and flexibility, this method of voltage control costs more mainly due to the additional floor space it needs. The methods of voltage regulation discussed so far basically use the principle of tap changing and hence the voltage change takes place in steps. Applications like a.c. and D.C. motor speed control, illumination control by dimmers, electro-chemistry and voltage stabilizers need continuous control of voltage. This can be obtained with the help of moving coil voltage regulators. Moving coil voltage regulator shows the physical arrangement of one such transformer. a, b are the two primary windings wound on a long core, wound in the opposite sense. Thus the flux produced by each winding takes a path through the air to link the winding. These fluxes link their secondaries a2 and b2. A short circuited moving coil s is wound on the same limb and is capable of being held at any desired position. This moving coil alters the inductances of the two primaries. The sharing of the total applied voltage thus becomes different and also the induced emf in the secondaries a2 and b2.

The total secondary voltage in the present case varies from 10 percent to 20 percent of the input in a continuous manner. The turn's ratios of a1: a2 and b1: b2 are 4.86 and 10.6 respectively. $5 \times 4.86 + 95 \times 10.6 = 10\%$ when s is in the top position. In the bottom position it becomes $95 \times 4.86 + 5 \times 10.6 = 20\%$. By selecting proper ratios for the secondaries a2 and b2 one can get the desired voltage variation. Sliding contact regulators these have two winding or auto transformer like construction. The winding from which the output is taken is bared and a sliding contact taps the voltage. The minimum step size of voltage change obtainable is the voltage across a single turn. The conductor is chosen on the basis of the maximum load current on the output side. In smaller ratings this is highly cost effective. Two winding arrangements are also possible. The two winding arrangement provides electrical isolation also.

2.11 SOLVED PROBLEMS

Example 1:

A source which can be represented by a voltage source of 8 V rms in series with an internal resistance of 2 kΩ is connected to a 50-Ω load resistance through an ideal transformer. Calculate the value of turns ratio for which maximum power is supplied to the load and the corresponding load power? Using MATLAB, plot the the power in milliwatts supplied to the load as a function of the transformer ratio, covering ratios from 1.0 to 10.0.

Solution:

For maximum power transfer, the load resistance (referred to the primary) must be equal to the source resistance.

$$R'_L = \left(\frac{N_1}{N_2}\right)^2 R_L = n^2 R_L = 2000 \Rightarrow n = \sqrt{\frac{2000}{50}} = 6.32$$

The primary current:

$$I_1 = \frac{V_s}{2R_s} \Rightarrow \text{Power supplied to the load: } P_{load} = R'_L I_1^2 = R_s \frac{V_s^2}{4R_s^2} = \frac{V_s^2}{4R_s} = 8$$

For a general turns ratio n :

$$I_1 = \frac{V_s}{R_s + R'_L} = \frac{V_s}{R_s + n^2 R_L} \Rightarrow P_{load} = R'_L I_1^2 = n^2 R_L \left(\frac{V_s}{R_s + n^2 R_L}\right)^2$$

Example 2

A 460-V:2400-V transformer has a series leakage reactance of 37.2 Ω as referred to the high-voltage side. A load connected to the low-voltage side is observed to be absorbing 25 kW, unity power factor, and the voltage is measured to be 450 V. Calculate the corresponding voltage and power factor as measured at the high-voltage terminals.

Solution:

Secondary current:

$$I_2 = \frac{P_{load}}{V_{load}} = \frac{25000}{450} = 55.55 \text{ A} \Rightarrow \text{Primary current } I_1 = \frac{460}{2400} \times 55.55 \approx 0.65 \text{ A}$$

Primary voltage:

$$V_1 = j37.2 I_1 + V'_2 \quad V'_2 = \frac{2400}{460} \times 450 = 2347.8 \text{ V}$$

$$\Rightarrow V_1 = j37.2 I_1 + V_2' = j37.2 \times 10.65 + 2347.8 = 2347.8 + j396.18 = 2381.0 \angle 9.58^\circ \text{ V}$$

Power factor at primary terminals: $\cos(9.58^\circ) = 0.9861$ lagging

Example 3:

The resistances and leakage reactances of a 30-kVA, 60-Hz, 2400-V:240-V distribution transformer are

$$R_1 = 0.68 \Omega \quad R_2 = 0.0068 \Omega$$

$$X_{l1} = 7.8 \Omega \quad X_{l2} = 0.0780 \Omega$$

where subscript 1 denotes the 2400-V winding and subscript 2 denotes the 240-V winding. Each quantity is referred to its own side of the transformer.

- Draw the equivalent circuit referred to (i) the high- and (ii) the low-voltage sides. Label the impedances numerically.
- Consider the transformer to deliver its rated kVA to a load on the low-voltage side with 230 V across the load. (i) Find the high-side terminal voltage for a load power factor of 0.85 lagging. (ii) Find the high-side terminal voltage for a load power factor of 0.85 leading.
- Consider a rated-kVA load connected at the low-voltage terminals operating at 240V. Use MATLAB to plot the high-side terminal voltage as a function of the power-factor angle as the load power factor varies from 0.6 leading through unity power factor to 0.6 pf lagging.

Solution:

(a)

(i) referred to the HV side

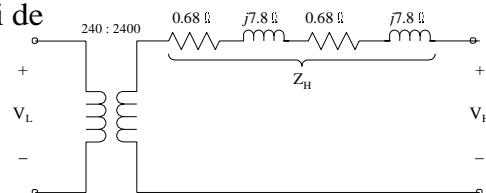

(ii) referred to the LV side

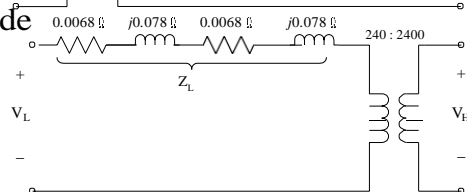

(b) Using the equivalent circuit referred to the HV side, $V_L = 230 \angle 0^\circ \text{ V}$

Load current: $I_{load} = \frac{30000}{230} \angle \phi = 93.8 \angle \phi \text{ A}$ where ϕ is the pf angle ($\phi > 0$ for leading pf).

Referred to the HV side:
 $I_H = 9.38 \angle \phi \text{ A} \Rightarrow V_H = V'_L + Z_H I_H = 2300 \angle 0^\circ + (1.36 + j15.6)9.38 \angle \phi$

$$V_H = 2300 + 12.7568 \cos \phi - 146.328 \sin \phi + j(146.328 \cos \phi + 12.7568 \sin \phi)$$

pf = 0.85 leading $\phi = 31.79^\circ \Rightarrow V_H = 2233.76 + j131.1 \approx 2237.6 \angle 3.46^\circ \text{ V}$

pf = 0.85 lagging $\phi = -31.79^\circ \Rightarrow V_H = 2387.93 + j117.66 = 2390.83 \angle 2.82^\circ \text{ V}$

Example 4:

A single-phase load is supplied through a 35-kV feeder whose impedance is $95 + j360 \Omega$ and a 35-kV:2400-V transformer whose equivalent impedance is $(0.23 + j1.27) \Omega$ referred to its low-voltage side. The load is 160 kW at 0.89 leading power factor and 2340 V.

- Compute the voltage at the high-voltage terminals of the transformer.
- Compute the voltage at the sending end of the feeder.

Compute the power and reactive power input at the sending end of the feeder.

Solution:

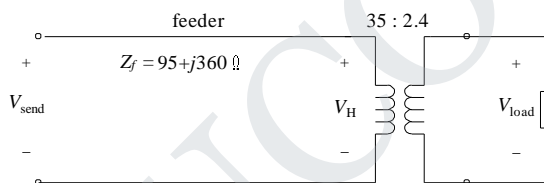

(a) Equivalent circuit for the transformer and load:

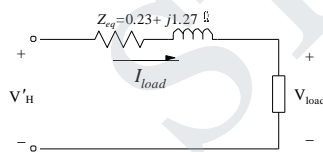

$$P_L = |V_{load}| |I_{load}| \cos \theta \Rightarrow |I_{load}| = \frac{160 \times 10^3}{2340 \times 0.89} = 76.83 \text{ A}$$

$$\theta = \cos^{-1} 0.89 = 27.13^\circ \text{ leading} \Rightarrow I_{load} = 76.83 \angle -27.13^\circ \text{ A}$$

The HV side voltage referred to the LV side:

$$V'_H = Z_{eq} I_{load} + V_L = (0.23 + j1.27)(76.83 \angle -27.13^\circ) + 2340 = 2311.2 + j94.9 \text{ V}$$

$$\Rightarrow V_H = \frac{35}{2.4} \times V'_H = 33.71 + j1.384 \text{ kV} \Rightarrow |V_H| = 33.734 \text{ kV}$$

(b) Load current referred to the HV side:

$$I'_{load} = I_{feed} = \frac{2.4}{35} \times 76.83 \angle 7.13^\circ = 5.2683 \angle 7.13^\circ \text{ A}$$

$$V_{send} = Z_f I_{feed} + V_H = (95 + j360) \times 5.2683 \angle 7.13^\circ + 3371 + j1384 = 33.286 + j3.3 \text{ kV}$$

$$|V_{send}| = 33.45 \text{ kV}$$

Example 5:

The following data were obtained for a 20-kVA, 60-Hz, 2400:240-V distribution transformer tested at 60 Hz:

	Voltage, V	Current, A	Power, W
With high-voltage winding open-circuited	240	1.038	122
With low-voltage terminals short-circuited	61.3	8.33	257

- Compute the efficiency at full-load current and the rated terminal voltage at 0.8 power factor.
- Assume that the load power factor is varied while the load current and secondary terminal voltage are held constant. Use a phasor diagram to determine the load power factor for which the regulation is greatest. What is this regulation?

Solution:

(a) Rated current on the HV side = 20 kVA / 2400 = 8.33 A. Therefore, total power loss at full load current:

$P_L = 122 + 257 = 379 \text{ W}$. Load power at full load, 0.8 pf = $0.8 \times 20 \text{ kW} = 16 \text{ kW}$. Therefore, input power = $16 + 0.379 = 16.379 \text{ kW} \Rightarrow$ efficiency = $(16 / 16.379) \times 100\% = 97.7\%$.

(b) The equivalent impedance of the transformer: $Z_{eq,H} = R_{eq,H} + jX_{eq,H}$

$$R_{eq,H} = \frac{P_{sc}}{I_{sc}^2} = \frac{257}{8.33^2} = 3.7 \Omega \quad |Z_{eq,H}| = \frac{V_{sc}}{I_{sc}} = \frac{61.3}{8.33} = 7.36 \Omega$$

$$\Rightarrow X_{eq,H} = \sqrt{(Z_{eq,H})^2 - (R_{eq,H})^2} = 6.36 \Omega$$

Let load current and voltage referred to the HV side: $V_{IH} = V \angle 0^\circ \quad I_{IH} = I \angle \theta$

$$V_s = V_{IH} + Z_{eq} I_{IH} = V + |Z_{eq} I_{IH}| \angle (\theta + \phi_Z) = V + V_d \angle \alpha \quad V_d = |Z_{eq} I_{IH}| \quad \text{and} \quad \alpha = \theta + \phi_Z$$

$$= (V + V_d \cos \alpha) + j V_d \sin \alpha$$

$$|V_s| = \sqrt{(V + V_d \cos \alpha)^2 + (V_d \sin \alpha)^2} = \sqrt{V^2 + 2VV_d \cos \alpha + V_d^2}$$

$$\text{Regulation} = \frac{|V_s| - |V_{IH}|}{|V_{IH}|} = \frac{\sqrt{V^2 + 2VV_d \cos \alpha + V_d^2} - V}{V} = \sqrt{1 + \frac{2V_d \cos \alpha}{V} + \frac{V_d^2}{V^2}} - 1$$

Therefore, regulation is maximum when $\cos \alpha$ is maximum

$$\Rightarrow \cos \alpha = 1 \Rightarrow \alpha = \theta + \phi_Z = 0 \Rightarrow \theta = -\phi_Z = -\tan^{-1} \left(\frac{X_{eqH}}{R_{eqH}} \right) = -59.81^\circ$$

Maximum regulation:

$$V_d = 7.36 \times 8.33 = 61.31 \text{ V}$$

$$\text{When } \alpha = 0^\circ \quad V_s = V + V_d \Rightarrow \text{Regulation} = \frac{V_d}{V} = \frac{61.31}{2400} = 0.026 = 2.6\%$$

Example 6:

A three-phase generator step-up transformer is rated 26-kV:345-kV, 850 MVA and has a series impedance of $0.0035 + j0.087$ per unit on this base. It is connected to a 26-kV, 800-MVA generator, which can be represented as a voltage source in series with a reactance of $j1.57$ per unit on the generator base.

- (a) Convert the per unit generator reactance to the step-up transformer base.
- (b) The unit is supplying 700 MW at 345 kV and 0.95 power factor lagging to the system at the transformer high-voltage terminals.
 - (i) Calculate the transformer low-side voltage and the generator internal voltage behind its reactance in kV.
- (ii) Find the generator output power in MW and the power factor.

Solution:

$$X_{gen} = 1.57 \times \left(\frac{850}{800} \right) = 1.668 \text{ pu}$$

(a) On the transformer base

(b) Per-unit equivalent circuit:

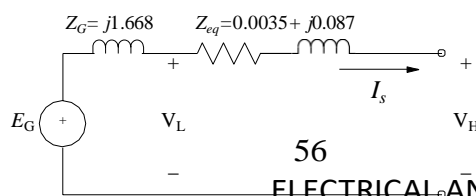

(i) Transformer low-side voltage and generator internal voltage:

$$V_{base,H} = 345 \text{ kV}, \quad V_{base,L} = 26 \text{ kV}, \quad VA_{base} = 850 \text{ MVA}$$

$$V_H = 1.0 \angle 0^\circ \text{ pu.}$$

$$|I_s| = \frac{700}{\sqrt{3} \times 345 \times 0.95} \text{ kA} = 1.233 \text{ kA} \quad I_{base,H} = \frac{VA_{base}}{\sqrt{3} \times V_{base,H}} = \frac{850}{\sqrt{3} \times 345} \text{ kA} = 1.4225 \text{ kA}$$

$$|I_s| = \frac{1.233}{1.4225} = 0.8668 \text{ pu.} \quad I_s = 0.8668 \angle -18.2^\circ \text{ pu.}$$

$$\text{OR} \quad P = \frac{700}{850} = 0.8235 \text{ pu.} \Rightarrow |I_s|_{pu} = \frac{P}{|V_H|_{pu} \cos \theta} = \frac{0.8235}{1 \times 0.95} = 0.8668 \text{ pu.}$$

$$V_L = V_H + (0.0035 + j0.087)I_s = 1.0264 + j0.071 \text{ pu.} \quad \angle 3.94^\circ$$

$$\Rightarrow |V_L| = 1.0289 \text{ pu.} \quad 26.75 \text{ kV}$$

$$E_G = V_L + (j1.668)I_s = 1.478 + j1.4442 \text{ pu.} \quad \angle 44.34^\circ \quad |E_G| = 26 \angle 44.34^\circ \text{ kV}$$

(ii) Generator output power (at its terminals)

$$S_G = V_L I_s^* = 1.0289 \angle 3.94^\circ \times 0.8668 \angle 18.2^\circ = 0.8261 + j0.3361 \text{ pu.}$$

$$P_G = 0.8261 \times 850 = 702.19 \text{ MW}$$

$$\text{power factor} = \cos(\tan^{-1} \frac{0.3361}{0.8261}) = 0.9263 \text{ lagging}$$

CHAPTER- 3

ELECTROMECHANICAL ENERGY CONVERSION AND CONCEPTS IN ROTATING MACHINES**Energy In Magnetic Systems**

It is often necessary in today's computer controlled industrial setting to convert an electrical signal into a mechanical action. To accomplish this, the energy in the electrical signal must be converted to mechanical energy. A variety of devices exist that can convert electrical energy into mechanical energy using a magnetic field. One such device, often referred to as a reluctance machine, produces a translational force whenever the electrical signal is applied. There are several variations of the reluctance machine but all operate on the same basic electromechanical principles.

The principles of electromechanical energy conversion are investigated. The motivation for this investigation is to show how the governing equations of an electromechanical device can be derived from a magnetic circuit analysis. An expression for the mechanical force will be derived in terms of the magnetic system parameters.

Electromechanical-Energy-Conversion Principles

The electromechanical-energy-conversion process takes place through the medium of the electric or magnetic field of the conversion device of which the structures depend on their respective functions.

Transducers: microphone, pickup, sensor, loudspeaker

Force producing devices: solenoid, relay, electromagnet

Continuous energy conversion equipment: motor, generator

This chapter is devoted to the principles of electromechanical energy conversion and the analysis of the devices accomplishing this function. Emphasis is placed on the analysis of systems that use magnetic fields as the conversion medium. The concepts and techniques can be applied to a wide range of engineering situations involving electromechanical energy conversion. Based on the energy method, we are to develop expressions for forces and torques in magnetic-field-based electromechanical systems.

Forces and Torques in Magnetic Field Systems

The Lorentz Force Law gives the force on a particle of charge in the presence of electric and magnetic fields.

F : newtons, q : coulombs, E : volts/meter, qEB : telsas, v : meters/second

In a pure electric-field system, $F=qE$

In pure magnetic-field systems, $F=q*(v*B)$

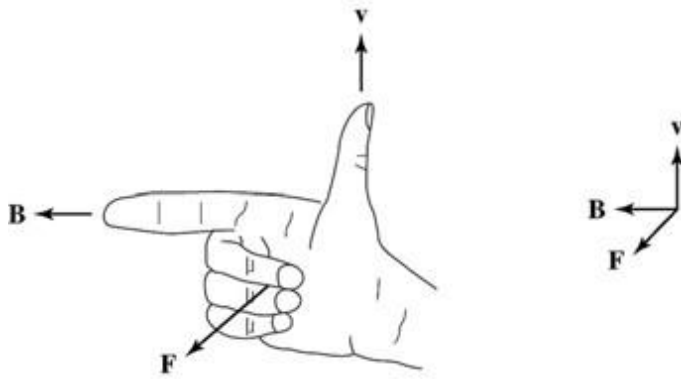

Figure 3.1 Right-hand rule for $F=q*(v*B)$

For situations where large numbers of charged particles are in motion $F=J*V$ most electromechanical-energy-conversion devices contain magnetic material. Forces act directly on the magnetic material of these devices which are constructed of rigid, nondeforming structures. The performance of these devices is typically determined by the net force, or torque, acting on the moving component. It is rarely necessary to calculate the details of the internal force distribution. Just as a compass needle tries to align with the earth's magnetic field, the two sets of fields associated with the rotor and the stator of rotating machinery attempt to align, and torque is associated with their displacement from alignment. In a motor, the stator magnetic field rotates ahead of that of the rotor, pulling on it and performing work. For a generator, the rotor does the work on the stator.

The Field Energy

Based on the principle of conservation of energy: energy is neither created nor destroyed; it is merely changed in form.

Energy Balance

Fig. 3.3(a): a magnetic-field-based electromechanical-energy-conversion device. A lossless magnetic-energy-storage system with two terminals

The electric terminal has two terminal variables: (voltage), (current).

The mechanical terminal has two terminal variables: (force), (position)

The loss mechanism is separated from the energy-storage mechanism.

– Electrical losses: ohmic losses.

– Mechanical losses: friction, windage.

A simple force-producing device with a single coil forming the electric terminal, and a movable plunger serving as the mechanical terminal.

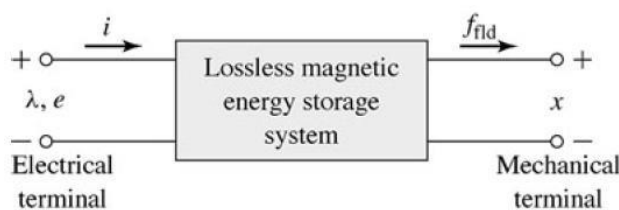

Figure 3.2 Schematic Magnetic field

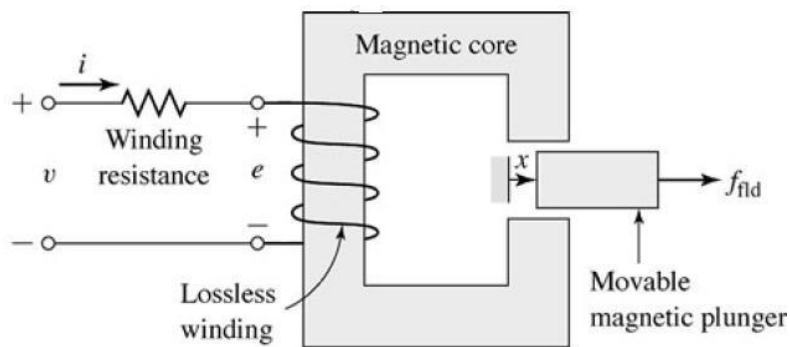

Figure 3.3 Simple force producing device

The interaction between the electric and mechanical terminals, i.e. the electromechanical energy conversion, occurs through the medium of the magnetic stored energy. Equation (3.9) permits us to solve for the force simply as a function of the flux λ and the mechanical terminal position x . Equations (3.7) and (3.9) form the basis for the energy method.

Consider the electromechanical systems whose predominant energy-storage mechanism is in magnetic fields. For motor action, we can account for the energy transfer.

$$\begin{pmatrix} \text{Energy input} \\ \text{from electric} \\ \text{sources} \end{pmatrix} = \begin{pmatrix} \text{Mechanical} \\ \text{energy} \\ \text{output} \end{pmatrix} + \begin{pmatrix} \text{Increase in energy} \\ \text{stored in magnetic} \\ \text{field} \end{pmatrix} + \begin{pmatrix} \text{Energy} \\ \text{converted} \\ \text{into heat} \end{pmatrix}$$

The ability to identify a lossless-energy-storage system is the essence of the energy method. This is done mathematically as part of the modeling process. For the lossless magnetic-energy-storage system of Fig. 3.3(a), rearranging (3.9) in form of (3.10) gives

$$d_{Welec} = d_{mech} + d_{fld}$$

Here E is the voltage induced in the electric terminals by the changing magnetic stored energy. It is through this reaction voltage that the external electric circuit supplies power to the coupling magnetic field and hence to the mechanical output terminals. The basic energy-conversion process is one involving the coupling field and its action and reaction on the electric and mechanical systems.

$$d_{Welec} = e i dt = d_{mech} + d_{fld}$$

The Co Energy

The magnetic stored energy is a state function, determined uniquely by the values of the independent state variables λ and x

Coenergy: Here the force can be obtained directly as a function of the current. The selection of energy or coenergy as the state function is purely a matter of convenience.

For a magnetically-linear system, the energy and coenergy (densities) are numerically equal:

$$W_{fld} + W'_{fld} = \lambda i$$

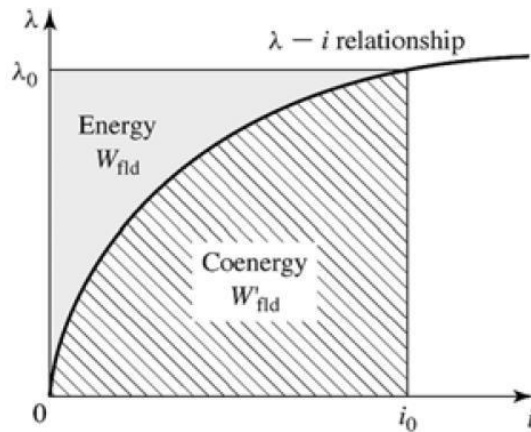

Figure 3.4 Graphical interpretation of energy and coenergy in a singly excited system.

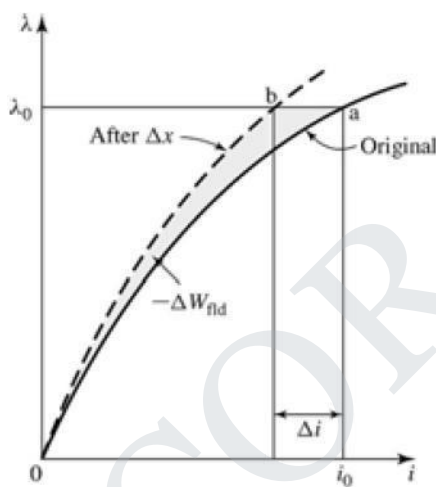

Figure 3.5 change of energy with λ held constant

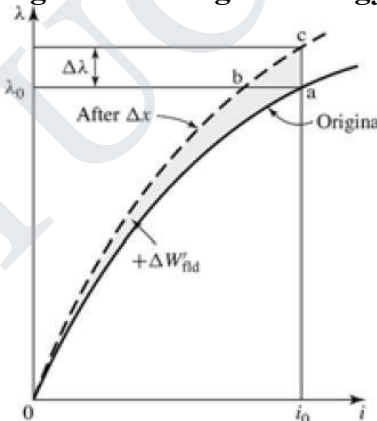

Figure 3.6 change of coenergy with i held constant.

The force acts in a direction to decrease the magnetic field stored energy at constant flux or to increase the coenergy at constant current. In a singly-excited device, the force acts to increase the inductance by pulling on members so as to reduce the reluctance of the magnetic path linking the winding.

Force In A Singly Excited Magnetic Field System

Model & Analysis

The conversion of electrical energy to mechanical energy follows the law of conservation of energy. In general, the law of conservation of energy states that energy is neither created nor destroyed. Equation (1) describes the process of electromechanical energy conversion for a differential time interval dt , where dW_e is the change in electrical energy, dW_m is the change in mechanical energy, and dW_f is the change in magnetic field energy. Energy losses in the form of heat are neglected.

$$dW_e = dW_m + dW_f \quad (1)$$

If the electrical energy is held constant, the dW_e term is zero for Equation (1). The differential mechanical energy, in the form of work, is the force multiplied by the differential distance moved. The force due to the magnetic field energy is shown in Equation (2). The negative sign implies that the force is in a direction to decrease the reluctance by making the air gap smaller.

$$f_m = \frac{-dW_f}{dx} \quad (2)$$

An expression for the energy stored in the magnetic field can be found in terms of the magnetic system parameters. This expression is then substituted into Equation (2) for W_f to get an expression for the force. This derivation is shown in Appendix A. The result is Equation (3), in terms of the current, i , the constant for the permeability of free space, μ_0 , the cross-sectional area of the air gap, A_g , the number of turns, N , and the air gap distance, x .

$$f_m = \frac{i^2 \mu_0 A_g N^2}{2x^2} \quad (3)$$

To verify this relationship in the lab, it is convenient to have an expression for the current necessary to hold some constant force. In a design, the dimensions and force are often known. So, the user of the reluctance machine needs to know how much current to supply. Rearranging terms in Equation (3) yields Equation (4).

$$i(x) = \sqrt{\frac{f_m \cdot 2x^2}{\mu_0 A_g N^2}} \quad (4)$$

Sample Calculations

For the simple magnetic system of Figure 1, the current necessary to suspend the armature can be calculated using Equation (4).

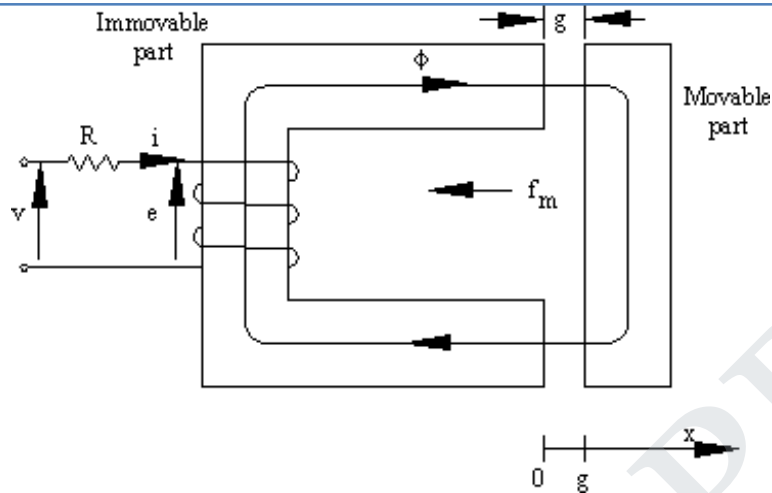

Figure 3.7. Electromechanical system.

For an air gap length of 0.12 mm, an air gap cross sectional area of 1092 mm², and a 230 turn coil the current required to just suspend the 12.5 newton armature is

$$i(0.12\text{mm}) = \sqrt{\frac{(12.5\text{newton}) \cdot 2 \cdot (0.00012\text{m})^2}{(4 \cdot \pi \cdot 10^{-7} \frac{\text{Henry}}{\text{m}}) \cdot (1.092 \cdot 10^{-3} \text{m}^2) \cdot 230^2}} = 100\text{mA}$$

(5) 3.4.3 Derivation of Magnetic Field Energy and Magnetic Force

Let \$W_f\$ be the energy stored in a magnetic field.

$$W_f = \int e \cdot i dt$$

$$e = \frac{d\lambda}{dt} \text{ where } \lambda \text{ is flux linkages, } \lambda = N \cdot \Phi = L \cdot i$$

$$W_f = \int \frac{d\lambda}{dt} \cdot i dt = \int i d\lambda = \int \frac{\lambda}{L} \cdot d\lambda = \frac{1}{2} \cdot \frac{\lambda^2}{L} = \frac{1}{2} \cdot i^2 \cdot L(x)$$

\$L(x)\$ is the inductance as a function of the air gap length, \$x\$.

$$L(x) = \frac{N^2}{\frac{x}{\mu_0 \cdot A_g}} = \frac{N^2}{x} = \frac{\mu_0 \cdot A_g \cdot N^2}{x}$$

where \$A_g\$ is the area of the air gap.

The magnetic force is

$$f_m = -\frac{1}{2} i^2 \cdot \frac{dL(x)}{dx} = \frac{i^2 \mu_0 A_g N^2}{2x^2}$$

Force In A Multiply Excited Magnetic Field System

For continuous energy conversion devices like

Alternators, synchronous motors etc., multiply excited magnetic systems are used. In practice ,doubly excited systems are very much in use.

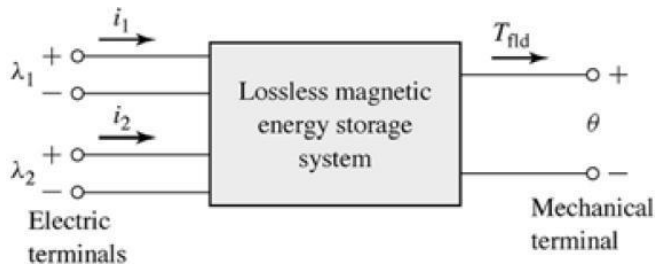

Figure 3.8. Electromechanical system.

The Figure 3.8 shows doubly excited magnetic system. This system has two independent sources of excitations. One source is connected to coil on stator while other is connected to coil on rotor.

- Let i_1 = Current due to source 1
- i_2 = Current due to source 2
- = Flux linkages due to i_1
- = Flux linkages due to i_2
- = Angular displacement of rotor
- T_f = Torque developed

Due to two sources, there are two sets of three independent variables

i.e. (,) or (i_1, i_2, θ)

Case:1 Independent Variables , i.e. $i_1, i_2,$

From the easier analysis it is known,

$T_f = \dots$ Currents are Variables (1)

While the field energy is,

$W_f(,) = + \dots$ (2)

Now let L_{11} = Self inductance of stator

L_{22} = Self inductance of rotor

$L_{12} = L_{21}$ = Mutual inductance between stator and rotor

$$= L_{11} i_1 + L_{12} i_2 \dots\dots\dots(3)$$

And
$$= L_{12} i_1 + L_{22} i_2 \dots\dots\dots(4)$$

Solve equation (3) and (4) to express i_1 and i_2 in terms of θ and ω as independent variables.

Multiply equation (3) by L_{22} and equation (4) by L_{11} ,

$$L_{22} = L_{11}L_{22} i_1 + L_{12}^2 i_2$$

and
$$L_{11} = L_{11}L_{12} i_1 + L_{11}L_{22} i_2$$

Subtracting the two ,

$$\begin{aligned} L_{22} - L_{11} &= L_{12}^2 i_2 - L_{11}L_{22} i_2 \\ &= [L_{12}^2 - L_{11}L_{22}]i_2 \end{aligned}$$

$$i_2 = \frac{\dots\dots\dots}{\dots\dots\dots} - \frac{\dots\dots\dots}{\dots\dots\dots}$$

$$i_2 = \dots\dots\dots + \dots\dots\dots(5)$$

Note that negative sign is absorbed in defining $\dots\dots\dots$.

Similarly i_1 can be expressed in terms of θ and ω as ,

$$i_1 = \dots\dots\dots + \dots\dots\dots(6)$$

Where
$$= \frac{\dots\dots\dots}{\dots\dots\dots}$$

$$= \frac{\dots\dots\dots}{\dots\dots\dots}$$

$$= \frac{\dots\dots\dots}{\dots\dots\dots}$$

Using in equation (2),

$$W_f(\theta, \omega) = \dots\dots\dots + \dots\dots\dots$$

Integrating the terms we get ,

$$W_f(\theta, \omega) = - \dots\dots\dots + \dots\dots\dots \dots\dots\dots$$

(7)

The self and mutual inductances of the coils are dependent on the angular position of the rotor.

Case :2 Independent Variables i_1, i_2 , i.e., i_1 and i_2 are constants.

The torque developed can be expressed as ,

$$T_f = \dots\dots\dots(8)$$

The co-energy is given by ,

$$= \dots\dots\dots(9)$$

Using $\dots\dots\dots = L_{11} i_1 + L_{12} i_2$

and $\dots\dots\dots = L_{12} i_1 + L_{22} i_2$

$$\dots\dots\dots = \dots\dots\dots + \dots\dots\dots$$

$$\dots\dots\dots = - \dots\dots\dots + - \dots\dots\dots$$

(10)

Force in a doubly excited system :

$$F = \dots\dots\dots$$

Where $\dots\dots\dots$ are constants which are the stator and rotor current respectively

$$F = \dots\dots\dots + \dots\dots\dots]$$

$$F = \dots\dots\dots + \dots\dots\dots$$

**Mmf Of Distributed Windings
Alternating Field Distribution**

Spatial field distribution and zerocrossings remain the same, whereas the field strength amount changes periodically with current frequency. This kind of field is called *alternating field*.

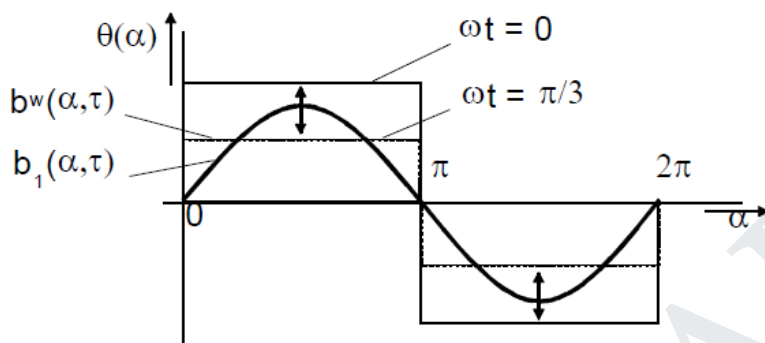

Figure 4.5 Alternating field distribution

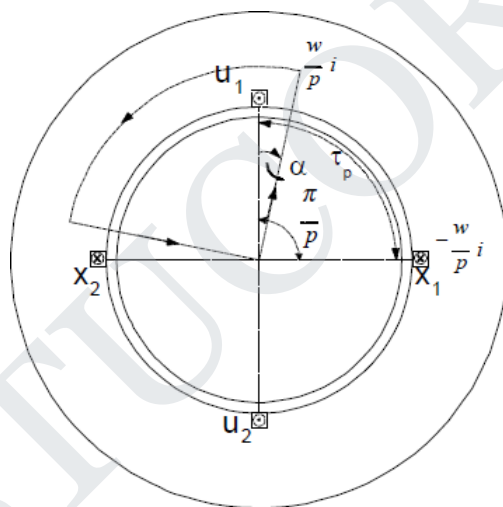

Figure 4.6 Stator, two pole-pairs

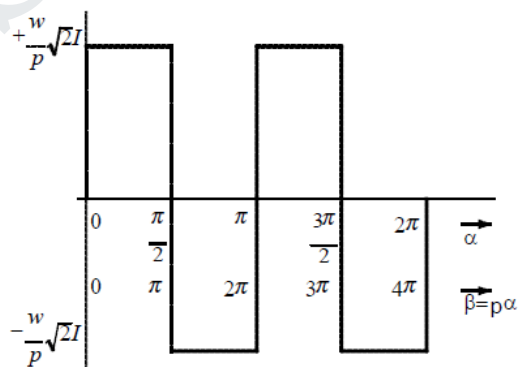

Figure 4.7 mmf for two pole-pair stator

The fundamental wave of the square-wave function (Figure. 131 etc.) can be determined by Fourier analysis. This results in an infinite count of single waves of odd ordinal numbers and anti-proportional decreasing amplitude with ordinary numbers. The amplitudes of fundamental waves and harmonics show proportional dependency to the current, zero crossings remain the same. These are called standing wave. The existence of harmonics is to be attributed to the spatial distributions of the windings. The generating current is of pure sinusoidal form, not containing harmonics. It necessarily needs to be distinguished between

- **wave:** spatiotemporal behaviour,
- **oscillation:** pure time dependent behavior

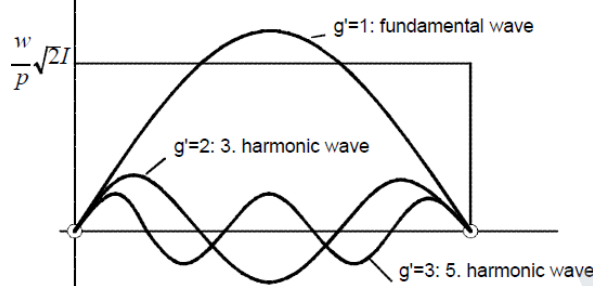

Figure 4.8 Fundamental wave, 3rd and 5th harmonics

Rotating field

Rotating fields appear as spatially distributed fields of constant form and amount, revolving with angular speed ω_1 :

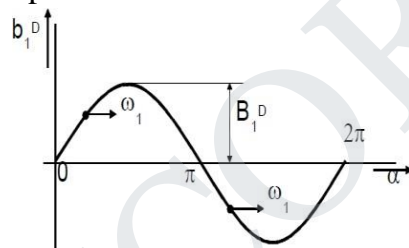

Figure 4.9 progressive wave

A sinusoidal alternating field can be split up into two sinusoidal rotating fields. Their peak value is of half the value as of the according alternating field, their angular speeds are oppositely signed

Three-phase winding

Most simple arrangement of a three-phase stator consist of:

1. core stack composed of laminations with approximately 0,5 mm thickness, mutual insulation for a reduction of eddy currents

2. The number of pole pairs is $p=1$ in Fig.138. In case of $p>1$, the configuration repeats p -times along the circumference.

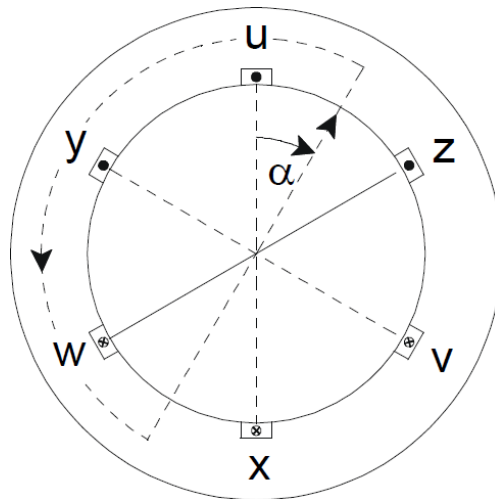

Figure 4.10 Three-phase stator, rotational angle

Determination of slot mmf for different moments (temporal)

- quantity of slot mmf is applied over the circumference angle.
- line integrals provide enveloped mmf, dependent on the circumference angle.
- total mmf is shaped like a staircase step function, being constant between the slots. At slot edges, with slots assumed as being narrow, the total mmf changes about twice the amount of the slot mmf, the air gap field results from the total mmf

Magnetic Fields In Rotating Machines

Winding factor

If w windings per phase are not placed in two opposing slots, but are moreover spread over more than one slot (zone winding) and return conductors are returned under an electric angle smaller than $< 180^\circ$, the effective number of windings appears smaller than it is in real

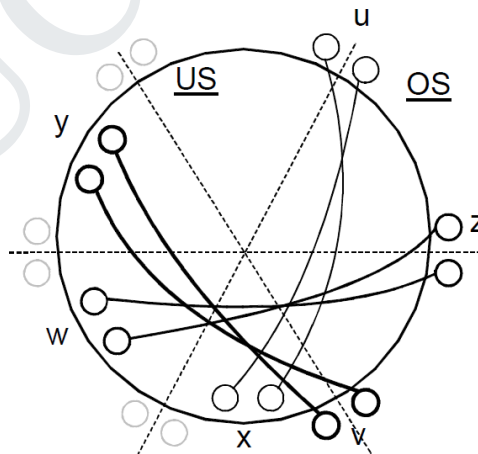

Figure 4.11 Three-phase winding, chording

This means is utilized for a suppression of harmonics, which cause parasitic torques and losses, influencing proper function of a machine. Actually there is no machine with $q \square 1$. Only zoning and chording enable disregarding harmonics.

Rotating Magnetic Field

A symmetric rotating magnetic field can be produced with as few as three coils. The three coils will have to be driven by a symmetric 3-phase AC sine current system, thus each phase will be shifted 120 degrees in phase from the others. For the purpose

of this example, the magnetic field is taken to be the linear function of the coil's current.

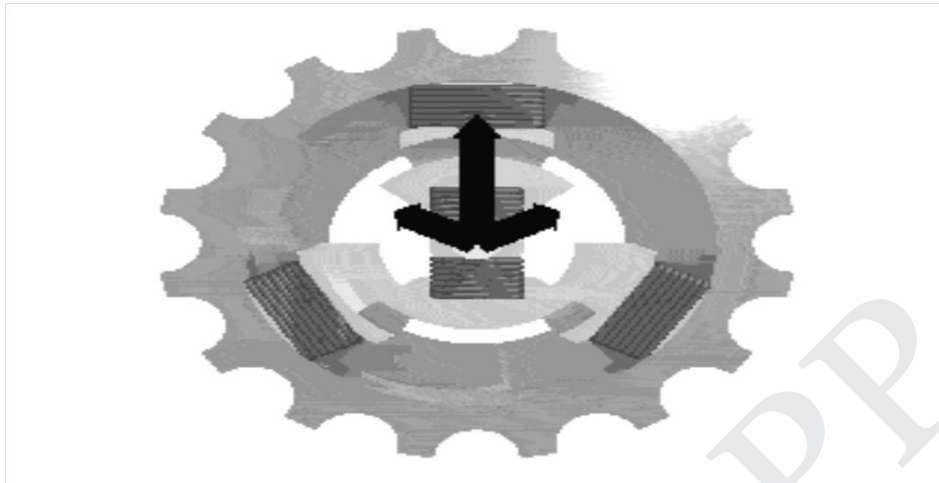

Figure 4.12 Coils

Sine wave current in each of the coils produces sine varying magnetic field on the rotation axis. Magnetic fields add as vectors. Vector sum of the magnetic field vectors of the stator coils produces a single rotating vector of resulting rotating magnetic field.

The result of adding three 120-degree phased sine waves on the axis of the motor is a single rotating vector. The rotor has a constant magnetic field. The N pole of the rotor will move toward the S pole of the magnetic field of the stator, and vice versa. This magneto-mechanical attraction creates a force which will drive rotor to follow the rotating magnetic field in a synchronous manner.

A permanent magnet in such a field will rotate so as to maintain its alignment with the external field. This effect was utilized in early alternating current electric motors. A rotating magnetic field can be constructed using two orthogonal coils with a 90 degree phase difference in their AC currents. However, in practice such a system would be supplied through a three-wire arrangement with unequal currents.

This inequality would cause serious problems in the standardization of the conductor size. In order to overcome this, three-phase systems are used where the three currents are equal in magnitude and have a 120 degree phase difference. Three similar coils having mutual geometrical angles of 120 degrees will create the rotating magnetic field in this case. The ability of the three phase system to create the rotating field utilized in electric motors is one of the main reasons why three phase systems dominate in the world electric power supply systems.



Figure 4.13 Coil

Rotating magnetic fields are also used in induction motors. Because magnets degrade with time, induction motors use short-circuited rotors (instead of a magnet) which follow the rotating magnetic field of a multicoiled stator. In these motors, the short circuited turns of the rotor develop eddy currents in the rotating field of stator which in turn move the rotor by Lorentz force. These types of motors are not usually synchronous, but instead necessarily involve a degree of 'slip' in order that the current may be produced due to the relative movement of the field and the rotor.

The single coil of a single phase induction motor does not produce a rotating magnetic field, but a pulsating 3- ϕ motor runs from 1- ϕ power, but does not start.

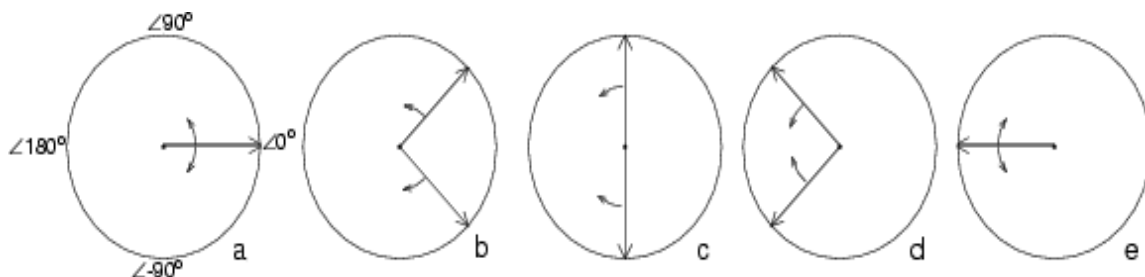
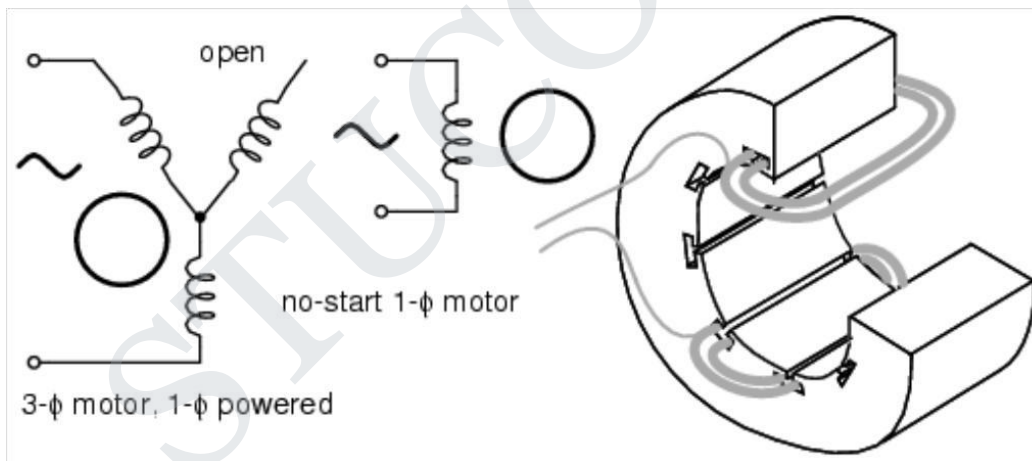

Figure 4.14 Single Phase Stator Produces a Non Rotating Pulsating Magnetic Field

Another view is that the single coil excited by a single phase current produces two counter rotating magnetic field phasor, coinciding twice per revolution at 0° (Figure above-a) and 180° (figure e). When the phasor rotate to 90° and -90° they cancel in figure b. At 45° and -45° (figure c) they are partially additive along the $+x$ axis and cancel along the y axis. An analogous situation exists in figure d. The sum of these two phasor is a phasor stationary in space, but alternating polarity in time. Thus, no starting torque is developed.

However, if the rotor is rotated forward at a bit less than the synchronous speed, It will develop maximum torque at 10% slip with respect to the forward rotating phasor. Less torque will be developed above or below 10% slip. The rotor will see 200% - 10% slip with respect to the counter rotating magnetic field phasor. Little torque (see torque vs. slip curve) other than a double frequency ripple is developed from the counter rotating phasor.

Thus, the single phase coil will develop torque, once the rotor is started. If the rotor is started in the reverse direction, it will develop a similar large torque as it nears the speed of the backward rotating phasor. Single phase induction motors have a copper or aluminum squirrel cage embedded in a cylinder of steel laminations, typical of poly-phase induction motors.

Distribution factor

All w/p windings per pole and phase are distributed over q slots. Any of the w/pq conductors per slot show a spatial displacement of.

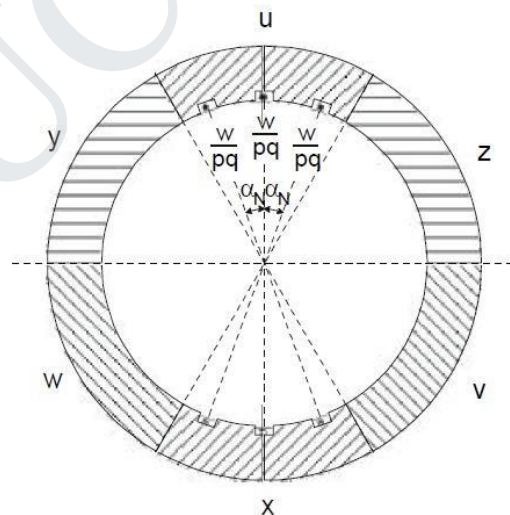

Figure 4.15 Stator, distribution factor

The resulting number of windings w resper phase is computed by geometric addition of all q partial windings w/pq . The vertices of all q phasors per phase, being displaced by $\square N$ (electrically), form a circle. The total angle per phase adds up to $q \square N$.

Purpose: The purpose of utilizing zone winding is to aim

- slot mmf fundamental waves adding up
- harmonics compensating each other, as they suppose to do.

Pitch factor

If windings are not implemented as diametral winding, but as chorded winding, return-line conductor are not displaced by an entire pole pitch τ_p (equal to 180° electrical), but only by an angle s τ_p , being $< 180^\circ$ (el.). Mentioned stepping s/τ_p can only be utilized for entire slot pitches $\tau_p = 2\tau/N$. In practice the windings are distributed over two layers. Line conductors are placed into the bottom layer, whereas return conductors are integrated into the top layer. That arrangement complies with a superposition of two winding systems of halved number of windings, being displaced by an angle α_S (mech.).

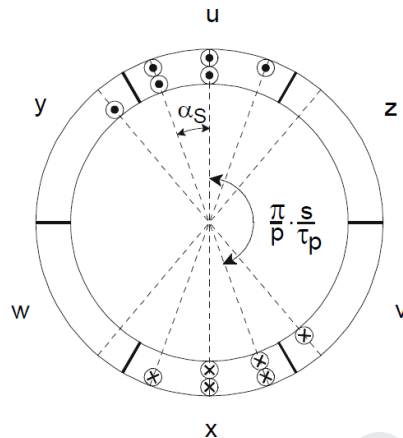

Figure 4.16 Three phase winding, chording

This leads to an electrical displacement of $\alpha_S = p\alpha$. Both fractional winding systems add up to the resulting number of windings.

Rotating Mmf Waves

The principle of operation of the induction machine is based on the generation of a rotating magnetic field. Let us understand this idea better.

Consider a cosine wave from 0 to 360° . This sine wave is plotted with unit amplitude.

- Now allow the amplitude of the sine wave to vary with respect to time in a sinusoidal fashion with a frequency of 50Hz. Let the maximum value of the amplitude is, say, 10 units. This waveform is a pulsating sine wave.

Now consider a second sine wave, which is displaced by 120° from the first (lagging).

- and allow its amplitude to vary in a similar manner, but with a 120° time lag. Similarly consider a third sine wave, which is at 240° lag.

- and allow its amplitude to change as well with a 240° time lag. Now we have three pulsating sine waves. Let us see what happens if we sum up the values of these three sine waves at every angle.

The result really speaks about Tesla's genius. What we get is a constant amplitude travelling sine wave!

In a three phase induction machine, there are three sets of windings, phase A winding, phase B and phase C windings. These are excited by a balanced three-phase voltage supply.

This would result in a balanced three phase current. Note that they have a 120° time lag between them. Further, in an induction machine, the windings are not all located in the same place. They are distributed in the machine 120° away from each other (more about this in the

section on alternators). The correct terminology would be to say that the windings have their axes separated in space by 120° . This is the reason for using the phase A, B and C since waves separated in space as well by 120° . When currents flow through the coils, they generate mmfs. Since mmf is proportional to current, these waveforms also represent the mmf generated by the coils and the total mmf. Further, due to magnetic material in the machine (iron), these mmfs generate magnetic flux, which is proportional to the mmf (we may assume that iron is infinitely permeable and non-linear effects such as hysteresis are neglected). Thus the waveforms seen above would also represent the flux generated within the machine. The net result as we have seen is a travelling flux wave. The x-axis would represent the space angle in the machine as one travels around the air gap. The first pulsating waveform seen earlier would then represent the a-phase flux, the second represents the b-phase flux and the third represents the c-phase. This may be better visualized in a polar plot. The angles of the polar plot represent the space angle in the machine, i.e., angle as one travels around the stator bore of the machine.

- This plot shows the pulsating wave at the zero degree axes. The amplitude is maximum at zero degree axes and is zero at 90° axis. Positive parts of the waveform are shown in red while negative in blue. Note that the waveform is pulsating at the $0-180^\circ$ axis and red and blue alternate in any given side. This corresponds to the sinewave current changing polarity. Note that the maximum amplitude of the sinewave is reached only along the $0-180^\circ$ axis. At all other angles, the amplitude does not reach a maximum of this value. It however reaches a maximum value which is less than that of the peak occurring at the $0-180^\circ$ axis. More exactly, the maximum reached at any space angle would be equal to \cos times the peak at the $0-180^\circ$ axis. Further, at any space angle, the time variation is sinusoidal with the frequency and phase lag being that of the excitation, and amplitude being that corresponding to the space angle.

- This plot shows the pulsating waveforms of all three cosines. Note that the first is pulsating about the $0-180^\circ$ axis, the second about the $120^\circ-300^\circ$ axis and the third at $240^\circ-360^\circ$ axis.

- This plot shows the travelling wave in a circular trajectory. Note that while individual pulsating waves have maximum amplitude of 10, the resultant has amplitude of 15. If f_1 is the amplitude of the flux waveform in each phase. It is worthwhile pondering over the following points.

1. what is the interpretation of the pulsating plots of the animation? If one wants to know the 'a' phase flux at a particular angle for all instants of time, how can it be obtained?

2. What will this time variation look like? It is obviously periodic. What will be the amplitude and frequency?

Voltage induction caused by influence of rotating field

Voltage in three-phase windings revolving at variable speed, induced by a rotating field is subject to computation in the following:

Spatial integration of the air gap field results in the flux linkage of a coil. Induced voltage ensues by derivation of the flux linkage with respect to time. Using the definition of slip and a transfer onto three-phase windings, induced voltages in stator and rotor can be discussed. The following considerations are made only regarding the fundamental wave

Flux linkage

The air gap field is created in the three-phase winding of the stator, characterized by the number of windings w_1 and current I_1 :

First of all, only one single rotor coil with number of windings w_2 and arbitrary position α angle of twist is taken into account. Flux linkage of the rotor coil results from spatial integration of the air gap flux density over one pole pitch.

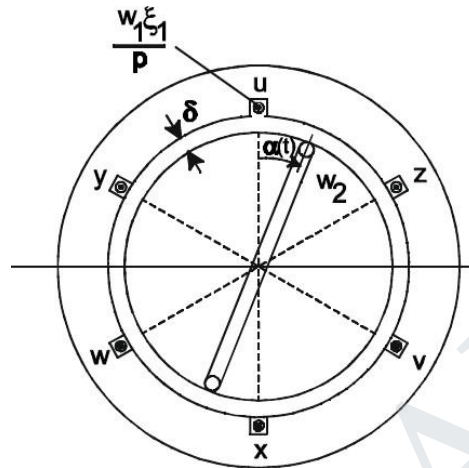

Figure 4.17 Three phase winding

Induced voltage, slip

Induced voltage in a rotor coil of arbitrary angle of twist $a(t)$, which is flowed through by the air gap flux density, computes from variation of the flux linkage with time. Described variation of flux linkage can be caused by both variation of currents $i_u(t)$, $i_v(t)$, $i_w(t)$ with time, inside the exciting three-phase winding and also by rotary motion $a(t)$ of the coil along the air gap circumference.

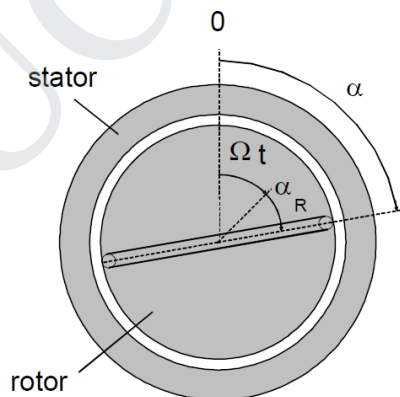

Figure 4.18 Rotor position, rotation angle

- Some aspects regarding induced voltage dependencies are listed below:
- the amplitude of the induced voltage is proportional to the line frequency of the stator and to the according slip.
- frequency of induced voltage is equal to slip frequency
- at rotor standstill ($s=1$), frequency of the induced voltage is equal to line frequency.
- when rotating ($s < 1$), voltage of different frequency is induced by the fundamental wave of the stator windings.

- no voltage is induced into the rotor at synchronous speed ($s=0$).
- phase displacement of voltages to be induced into the rotor is only dependent from the spatial position of the coil, represented by the (elec.) angle $p R a$. Is a rotor also equipped with a three-phase winding, instead of a single coil similar to the stator arrangement with phases being displaced by a mechanical angle, a number of slots per pole and phase greater than 1 ($q > 1$) and the resulting number of windings $w_2 \neq 2$, then follows for the induced voltage of single rotor phases.

Torque In Ac And Dc Machines

As fulfilled previous considerations, only the fundamental waves of the effects caused by the air gap field are taken into account. Rotating mmf, caused in stator windings, is revolving. An according rotating mmf is evoked in the rotor windings. Initially no assumptions are made for the number of pole pairs, angular frequency and phase angle of rotating magneto-motive forces of stator- and rotor. With appliance of Ampere's law, the resulting air gap field calculates from superimposing of both rotating magneto-motive forces of stator and rotor

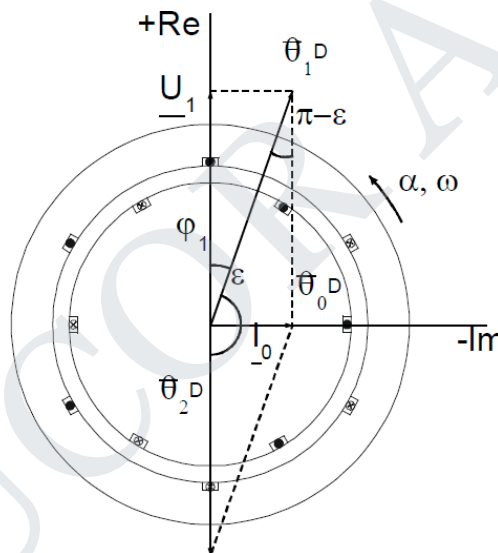

Figure 4.19 space vector representation for time vector representation

A time-variant sinusoidal torque with average value equal to zero appears which is called *oscillation torque*. Only if angular frequencies of the exciting currents agree, which means $\omega_1 = \omega_2 = \omega$ and therefore speed of rotation of stator and rotor rotating field agree (at equal number of pole pairs), a time-constant torque derives for $e \neq 0$: As to be seen in equation 6.93 the torque of two magneto-motive forces is proportional to their amplitudes and the sine-value of the enclosed angle.

$iM = \text{maximum for } e = \dots$

2. $M = 0$ for $\alpha = 0$

Magneto-motive force reflects the geometrical sum of stator and rotor mmf, which complies with the resulting air gap field. Displacement between U_1 and I_0 is represented by α . The voltage phasor U_1 is orientated in the direction of the +Re-axis (real) whereas I_0 is orientated in direction of the -Im-axis (imaginary), for complex coordinate presentation.

Torque In Ac Machines

Effective torque exerted on the shaft derives from transmitted air-gap power divided by synchronous speed. Neglecting stator copper losses, the absorbed active power is equal to the air-gap power.

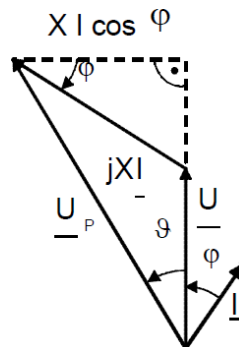

Figure 4.20 Synchronous machine phasor diagram

The torque equation (8.28) solely applies for stationary operation with $I_F = \text{const}$ and $n = n_1$. If the load increases slowly, torque and angular displacement increases also, until breakdown torque is reached at V , and the machine falls out of step – means standstill in motor operation and running away in generator mode. High pulsating torques and current peaks occur as a consequence of this. In this case machines need to be disconnected from the mains immediately. Overload capability, the ratio of breakdown torque and nominal torque, only depends on no load-short-circuit-ratio K_C and power factor.

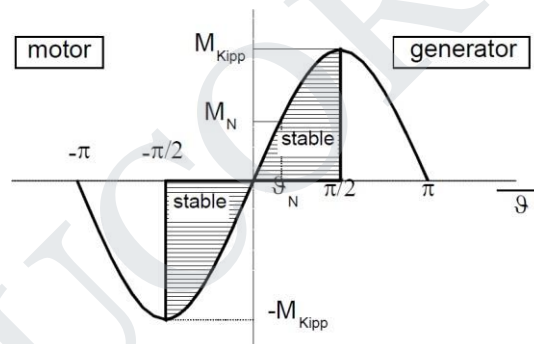

Figure 4.21 Range of operation

The higher dm/dv , the higher appears the back-leading torque M_{syn} after load impulse. The lower \square , the more stable the point of operation.

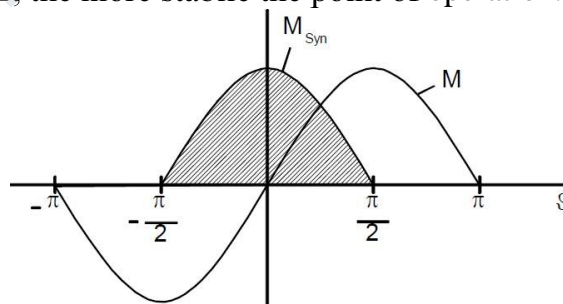

Figure 4.22 Synchronizing torque

SOLVED PROBLEMS

Example 1:

An actuator with a rotating vane is shown in Fig. 3.26. You may assume that the permeability of both the core and the vane are infinite ($\mu \rightarrow \infty$). The total air-gap length is $2g$ and shape of the vane is such that the effective area of the air gap can be assumed to be of the form

$$A_g = A_0 \left[1 - \left(\frac{4\theta}{\pi} \right)^2 \right]$$

(valid only in the range $|\theta| \leq \pi/6$). The actuator dimensions are $g = 0.8$ mm, $A_0 = 6.0$ mm², and $N = 650$ turns.

- (a) Assuming the coil to be carrying current i , write an expression for the magnetic stored energy in the actuator as a function of angle θ for $|\theta| \leq \pi/6$.

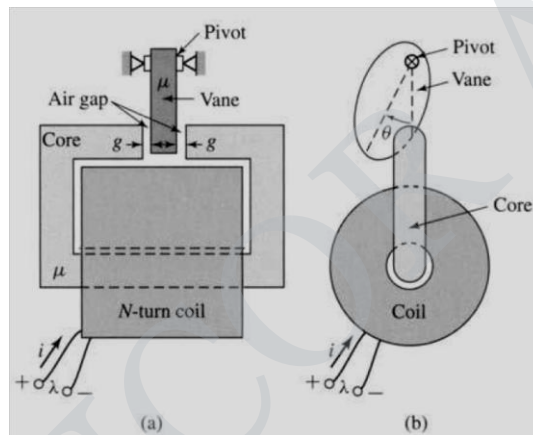

Figure 1 Actuator with rotating vane (a) Side view. (b) End view.

Solution

(a) Flux density in the air-gap: $B_g = \frac{\mu_0 Ni}{2g}$

Magnetic energy density $= \frac{1}{2} \frac{B_g^2}{\mu_0}$

$$\Rightarrow W_{fld} = \left(\frac{1}{2} \frac{B_g^2}{\mu_0} \right) \times V_{ag} \quad V_{ag} = 2gA_g \Rightarrow W_{fld} = \frac{\mu_0 N^2 i^2}{4g} A_0 \left[1 - \left(\frac{4\theta}{\pi} \right)^2 \right]$$

- (b)

$$W_{fld} = \frac{1}{2} L(\theta) i^2 \Rightarrow L(\theta) = \frac{2W_{fld}}{i^2} = \frac{\mu_0 N^2}{2g} A_0 \left[1 - \left(\frac{4\theta}{\pi} \right)^2 \right]$$

Example 2:

As shown in Fig. 2, an N -turn ($N = 100$) electromagnet is to be used to lift a slab of iron of mass M . The surface roughness of the iron is such that when the iron and the electromagnet are in contact, there is a minimum air gap of $g_{min} = 0.18$ mm in each leg. The electromagnet cross-sectional area $A_c = 32$ cm² and coil resistance is 2.8 Ω . Calculate the minimum coil voltage which must be used to lift a slab of mass 95 kg against the force of gravity. Neglect the reluctance of the iron.

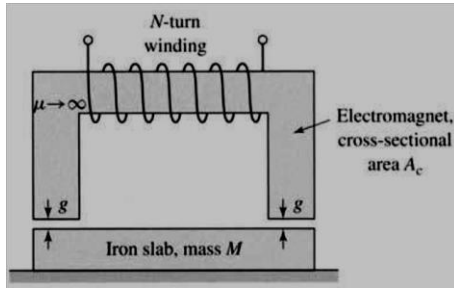

Solution

coil inductance:

$$L(g) = \frac{\mu_0 N^2 A_c}{2g} \Rightarrow f_{fd} = \frac{1}{2} i^2 \frac{dL}{dg} = -\frac{\mu_0 N^2 A_c}{4g^2} i^2$$

$$|f_{fd}| = Mg_e \quad g_e = 9.8 \text{ m/s}^2 \quad \text{: acceleration due to gravity} \quad \Rightarrow \quad |f_{fd}| = 931 \text{ N}$$

$$i_{\min} = \frac{2g_{\min}}{N} \sqrt{\frac{|f_{fd}|}{\mu_0 A_c}} = \frac{2 \cdot 0.18 \cdot 10^{-3}}{450} \sqrt{\frac{931}{4\pi \times 10^{-7} \times 32 \cdot 10^{-4}}} = 0.385 \text{ A}$$

$$v_{\min} = Ri_{\min} = 1.08 \text{ V}$$

Example :3

An inductor is made up of a 525-turn coil on a core of 14-cm² cross-sectional area and gap length 0.16 mm. The coil is connected directly to a 120-V 60-Hz voltage source. Neglect the coil resistance and leakage inductance. Assuming the coil reluctance to be negligible, calculate the time-averaged force acting on the core tending to close the air gap. How would this force vary if the air-gap length were doubled?

Solution

$$L = \frac{\mu_0 N^2 A_c}{g} \quad f_{fd} = \frac{1}{2} i^2 \frac{dL}{dg} = -\frac{1}{2} i^2 \left(\frac{\mu_0 N^2 A_c}{g^2} \right) = -\frac{i^2 L}{2g}$$

Since coil resistance and leakage inductance are negligible, the current in the coil can be written as

$$i(t) = I_m \cos \omega t \quad \text{where } I_m = \frac{V_m}{\omega L}$$

$$f_{fd} = -\frac{i^2 L}{2g} = -\frac{I_m^2 L}{2g} \cos^2 \omega t \Rightarrow \langle f_{fd} \rangle = -\frac{I_{rms}^2 L}{2g} = -\frac{V_{rms}^2 L}{2g \omega^2 L^2} = -\frac{V_{rms}^2}{2\omega^2 \mu_0 N^2 A_c}$$

$$\Rightarrow \langle f_{fd} \rangle = -\frac{120^2}{2(120\pi)^2 525^2 \times 4\pi \times 10^{-7} \times 14 \times 10^{-4}} = -104.48 \text{ N}$$

The average force is independent of the air-gap length g.

Example 5:

Two windings, one mounted on a stator and the other on a rotor, have self- and mutual inductances of

$$L_{11} = 4.5 \text{ H} \quad L_{22} = 2.5 \text{ H} \quad L_{12} = 2.8 \cos \theta \text{ H}$$

where θ is the angle between the axes of the windings. The resistances of the windings may be neglected. Winding 2 is short-circuited, and the current in winding 1 as a function of time is $i_1 = 10 \sin \omega t \text{ A}$.

- Derive an expression for the numerical value in newton-meters of the instantaneous torque on the rotor in terms of the angle θ .
- Compute the time-averaged torque in newton-meters when $\theta = 45^\circ$.
- If the rotor is allowed to move, will it rotate continuously or will it tend to come to rest? If the latter, at what value of θ_0 ?

$$(a) \quad T_{fld} = i_1 i_2 \frac{dL(\theta)}{d\theta} = -2.8 i_1 i_2 \sin \theta$$

Winding 2 short-circuited

$$e_2 = v_2 = 0 \Rightarrow \lambda_2 = L_{21} i_1 + L_{22} i_2 = 0 \Rightarrow i_2 = -\frac{L_{21} i_1}{L_{22}} = -1.12 i_1 \cos \theta$$

$$T_{fld} = -2.8 i_1 i_2 \sin \theta = -3.14 i_1^2 \sin \theta \cos \theta = -3.14 \sin^2(\omega t) \sin \theta \cos \theta$$

(b) Time-averaged torque

$$\langle T_{fld} \rangle = -157 \sin \theta \cos \theta \quad \theta = 45^\circ \Rightarrow \langle T_{fld} \rangle = -157 \left(\frac{1}{\sqrt{2}} \right) \left(\frac{1}{\sqrt{2}} \right) = -78.5 \text{ N-m}$$

Note: $\langle \sin^2(\omega t) \rangle = \frac{1}{\pi} \int_0^\pi \frac{\cos(2t)\omega}{2} dt = \frac{1}{2}$

- The rotor will not rotate because the average torque with respect to θ is zero. It will come to rest when

$$\sin \theta \cos \theta = \frac{1}{2} \sin(2\theta) = 0 \Rightarrow \theta = \frac{\pi}{2}$$

Example 6:

A loudspeaker is made of a magnetic core of infinite permeability and circular symmetry, as shown in Figs. 3.37a and b. The air-gap length g is much less than the radius r_0 of the central core. The voice coil is constrained to move only in the x direction and is attached to the speaker cone, which is not shown in the figure. A constant radial magnetic field is produced in the air gap by a direct current in coil 1, $i_1 = I_1$. An audio-frequency signal $i_2 = I_2 \cos(\omega t)$ is then applied to the voice coil. Assume the voice coil to be of negligible thickness and composed of N_2 turns uniformly distributed over its height h . Also assume that its displacement is such that it remains in the air gap ($0 \leq x \leq h$).

- Calculate the force on the voice coil, using the Lorentz Force Law (Eq. 3.1).
- Calculate the self-inductance of each coil.
- Calculate the mutual inductance between the coils. (Hint: Assume that current is applied to the voice coil, and calculate the flux linkages of coil 1. Note that these flux linkages vary with the displacement x .

- Calculate the force on the voice coil from the coenergy W'_{fld} .

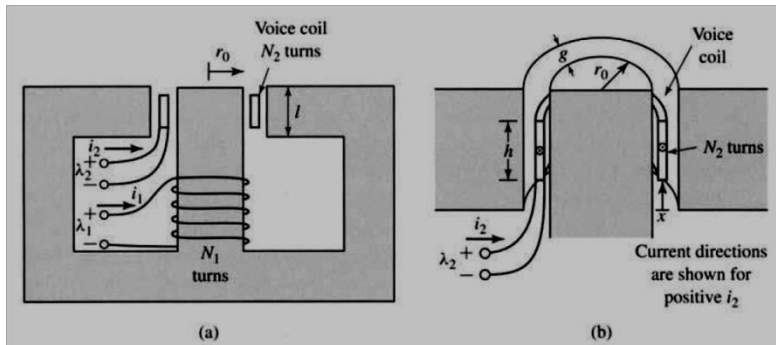

Solution

(a) Radial magnetic field intensity:
Lorentz force (directed upward):

$$Ni_1 = H_r g \Rightarrow B_{r,1} = \mu_0 H_r = \frac{\mu_0 N i_1}{g}$$

$$F = N_2 i_2 l_2 B_{r,1} \quad \text{where } l_2 = 2\pi r_0 \text{ is the length of one turn of coil 2.}$$

$$F = 2\pi r_0 N_1 N_2 i_1 i_2 = \frac{2\pi \mu_0 N_1 N_2 i_1 i_2}{g}$$

(b) Self-inductances:

$$L_{11} = \frac{\mu_0 N_1^2 A}{g} \quad A_g = 2\pi r_0 l$$

To find the self-inductance of coil 2, apply Ampere's law to coil 2 at height z:

$$H_{r,2} g = \left(\frac{z-x}{h}\right) N_2 i_2 = \text{total current enclosed by path } C \text{ at height } z$$

$$\therefore B_{r,2} = \begin{cases} 0 & 0 \leq z \leq x \\ -\left(\frac{z-x}{gh}\right) \mu_0 N_2 i_2 & x \leq z \leq x+h \\ -\frac{\mu_0 N_2 i_2}{g} & x+h \leq z \leq l \end{cases}$$

(c) We can find the inductance of a section of coil 2 of length dz and then integrate with respect to z. At a height z

$$\Delta L_{22}(z) = \frac{\Delta \lambda_2(z)}{I_2} \quad \Delta \lambda_2(z) = \Delta N_2 \int_z^l B_{r,2}(u) \cdot 2\pi r_0 du \quad z > x$$

where $\Delta N_2 = N_2 \Delta z$ is the number of turns of coil 2 in the section Δz

$$\int_z^l B_{r,2}(u) du = \frac{\mu_0 N_2 I_2}{gh} \int_z^l (u-x) du = \frac{\mu_0 N_2 I_2}{gh} \left[\frac{1}{2} u^2 - ux \right]_z^l$$

$$\Delta L_{22}(z) = \frac{2\pi \mu_0 N_2^2}{gh} \left[\frac{1}{2} l^2 - lx - \frac{1}{2} z^2 + zx \right] \Delta z$$

$$L_{22} = \frac{2\pi \mu_0 N_2^2}{gh} \int_x^{l-x} \left[\frac{1}{2} z^2 - lx - \frac{1}{2} z^2 + zx \right] dz = \frac{\pi \mu_0 N_2^2}{g} (l-x)^2$$

STUCOR APP

CHAPTER -4

DC GENERATORS

4.1 Principles Of D.C. Machines

D.C. machines are the electro mechanical energy converters which work from a D.C. source and generate mechanical power or convert mechanical power into a D.C. power.

Construction of d.c. Machines

A D.C. machine consists mainly of two part the stationary part called stator and the rotating part called rotor. The stator consists of main poles used to produce magnetic flux ,commutating poles or interpoles in between the main poles to avoid sparking at the Commutator but in the case of small machines sometimes the interpoles are avoided and finally the frame or yoke which forms the supporting structure of the machine. The rotor consist of an armature a cylindrical metallic body or core with slots in it to place armature windings or bars,aCommutator and brush gears The magnetic flux path in a motor or generator is show below and it is called the magnetic structure of generator or motor.

The major parts can be identified as,

1. Frame
2. Yoke
3. Poles Institute of Technology Madras
4. Armature
5. Commutator and brush gear
6. Commutating poles
7. Compensating winding
8. Other mechanical parts

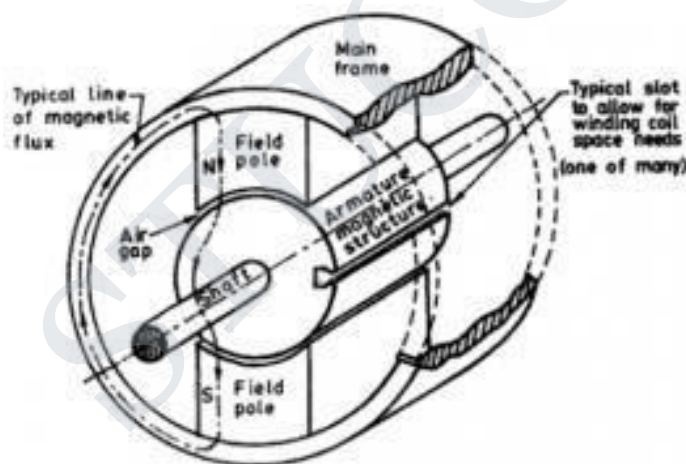

Figure.5.1D.C Machines

Frame

Frame is the stationary part of a machine on which the main poles and Commutator poles are bolted and it forms the supporting structure by connecting the frame to the bed plate. The ring shaped body portion of the frame which makes the magnetic path for the magnetic fluxes from the main poles and interpoles is called frames.

Yoke.

Yoke was made up of cast iron but now it is replaced by cast steel.This is because cast iron is saturated by a flux density of 0.8 Web/sq.mwhere as saturation

with cast iron steel is about 1.5 Web/sq.m. So for the same magnetic flux density the cross section area needed for cast steel is less than cast iron hence the weight of the machine too. If we use cast iron there may be chances of blow holes in it while casting. So now rolled steels are developed and these have consistent magnetic and mechanical properties.

End Shields or Bearings

If the armature diameter does not exceed 35 to 45 cm then in addition to poles end shields or frame head with bearing are attached to the frame. If the armature diameter is greater than 1m pedestral type bearings are mounted on the machine bed plate outside the frame. These bearings could be ball or roller type but generally plain pedestral bearings are employed. If the diameter of the armature is large a brush holder yoke is generally fixed to the frame.

Main poles

Solid poles of fabricated steel with separate/integral pole shoes are fastened to the frame by means of bolts. Pole shoes are generally laminated. Sometimes pole body and pole shoe are formed from the same laminations. The pole shoes are shaped so as to have a slightly increased air gap at the tips. Inter-poles are small additional poles located in between the main poles. These can be solid, or laminated just as the main poles.

These are also fastened to the yoke by bolts. Sometimes the yoke may be slotted to receive these poles. The inter poles could be of tapered section or of uniform cross section. These are also called as commutating poles or com poles. The width of the tip of the com pole can be about a rotor slot pitch.

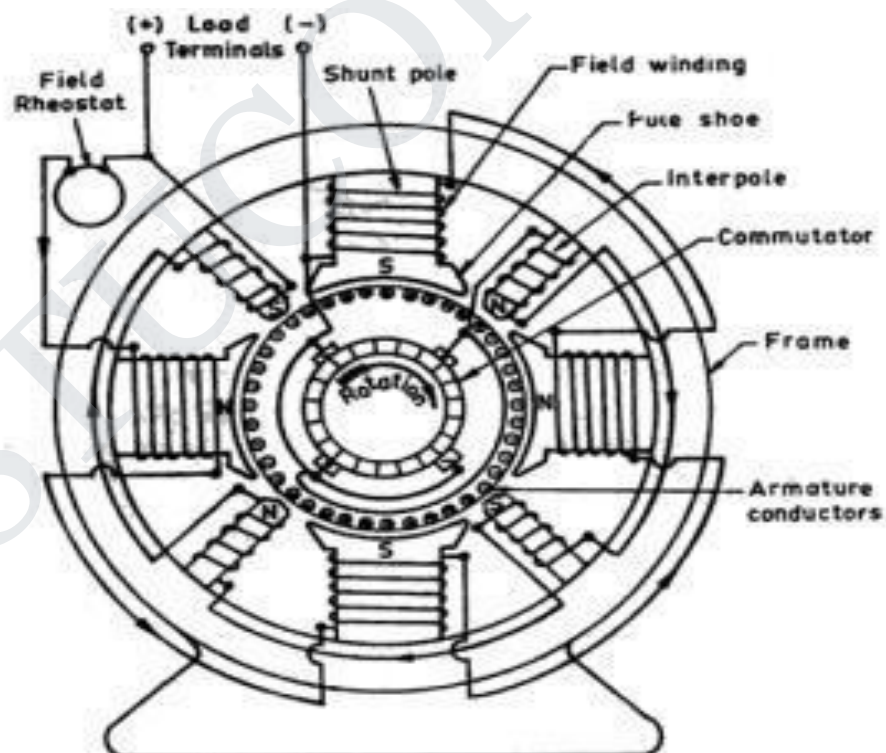

Figure.5.2 Parts of D.C Machine

Armature

The armature is where the moving conductors are located. The armature is constructed by stacking laminated sheets of silicon steel. Thickness of this lamination

is kept low to reduce eddy current losses. As the laminations carry alternating flux the choice of suitable material, insulation coating on the laminations, stacking it etc are to be done more carefully. The core is divided into packets to facilitate ventilation. The winding cannot be placed on the surface of the rotor due to the mechanical forces coming on the same. Open parallel sided equally spaced slots are normally punched in the rotor laminations.

These slots house the armature winding. Large sized machines employ a spider on which the laminations are stacked in segments. End plates are suitably shaped so as to serve as 'Winding supporters'. Armature construction process must ensure provision of sufficient axial and radial ducts to facilitate easy removal of heat from the armature winding. Field windings: In the case of wound field machines (as against permanent magnet excited machines) the field winding takes the form of a concentric coil wound around the main poles. These carry the excitation current and produce the main field in the machine. Thus the poles are created electromagnetically.

Two types of windings are generally employed. In shunt winding large number of turns of small section copper conductor is used. The resistance of such winding would be an order of magnitude larger than the armature winding resistance. In the case of series winding a few turns of heavy cross section conductor is used. The resistance of such windings is low and is comparable to armature resistance. Some machines may have both the windings on the poles. The total ampere turns required to establish the necessary flux under the poles is calculated from the magnetic circuit calculations.

The total mmf required is divided equally between north and south poles as the poles are produced in pairs. The mmf required to be shared between shunt and series windings are apportioned as per the design requirements. As these work on the same magnetic system they are in the form of concentric coils. Mmf 'per pole' is normally used in these calculations. Armature winding as mentioned earlier, if the armature coils are wound on the surface of

The armature, such construction becomes mechanically weak.

The conductors may fly away when the armature starts rotating. Hence the armature windings are in general pre-formed, taped and lowered into the open slots on the armature. In the case of small machines, they can be hand wound. The coils are prevented from flying out due to the centrifugal forces by means of bands of steel wire on the surface of the rotor in small grooves cut into it. In the case of large machines slot wedges are additionally used to restrain the coils from flying away.

The end portion of the windings are taped at the free end and bound to the winding carrier ring of the armature at the Commutator end. The armature must be dynamically balanced to reduce the centrifugal forces at the operating speeds. Compensating winding One may find a bar winding housed in the slots on the pole shoes. This is mostly found in D.C. machines of very large rating. Such winding is called compensating winding. In smaller machines, they may be absent.

Commutator

Commutator is the key element which made the D.C. machine of the present day possible. It consists of copper segments tightly fastened together with mica/micanite insulating separators on an insulated base. The whole Commutator forms a rigid and solid assembly of insulated copper strips and can rotate at high speeds. Each Commutator segment is provided with a 'riser' where the ends of the armature coils get connected. The surface of the Commutator is machined and surface is made concentric with the shaft and the current collecting brushes rest on the same. Under-cutting the mica insulators that are between these Commutator segments have

to be done periodically to avoid fouling of the surface of the Commutator by mica when the Commutator gets worn out.

Some details of the construction of the Commutator. Brush and brush holders: Brushes rest on the surface of the Commutator. Normally electro-graphite is used as brush material. The actual composition of the brush depends on the peripheral speed of the Commutator and the working voltage. The hardness of the graphite brush is selected to be lower than that of the Commutator. When the brush wears out the graphite works as a solid lubricant reducing frictional coefficient. More number of relatively smaller width brushes are preferred in place of large broad brushes.

The brush holders provide slots for the brushes to be placed. The connection Brush holder with a Brush and Positioning of the brush on the Commutator from the brush is taken out by means of flexible pigtail. The brushes are kept pressed on the Commutator with the help of springs. This is to ensure proper contact between the brushes and the Commutator even under high speeds of operation. Jumping of brushes must be avoided to ensure arc free current collection and to keep the brush contact drop low.

Other mechanical parts End covers, fan and shaft bearings form other important mechanical parts. End covers are completely solid or have opening for ventilation. They support the bearings which are on the shaft. Proper machining is to be ensured for easy assembly. Fans can be external or internal. In most machines the fan is on the non-Commutator end sucking the air from the Commutator end and throwing the same out. Adequate quantity of hot air removal has to be ensured.

Bearings Small machines employ ball bearings at both ends. For larger machines roller bearings are used especially at the driving end. The bearings are mounted press-fit on the shaft. They are housed inside the end shield in such a manner that it is not necessary to remove the bearings from the shaft for dismantling.

Lap Winding :

This type of winding is used in dc generators designed for high-current applications. The windings are connected to provide several parallel paths for current in the armature. For this reason, lap-wound armatures used in dc generators require several pairs of poles and brushes.

In lap winding, the finishing end of one coil is connected to a commutator segment and to the starting end of the adjacent coil situated under the same pole as so on, till all the coils have been connected. This type of winding derives its name from the fact it doubles or laps back with its succeeding coils. Following points regarding simplex lap winding should be noted:

1. The back and front pitches are odd and of opposite sign. But they can't be equal. They differ by 2 or some multiple thereof.
2. Both Y_B and Y_F should be nearly equal to a pole pitch.
3. The average pitch $Y_A = (Y_B + Y_F)/2$. It equals pole pitch = Z/P .
4. Commutator pitch $Y_C = \pm 1$.
5. Resultant pitch Y_R is even, being the arithmetical difference of two odd numbers i.e $Y_R = Y_B - Y_F$.
6. The number of slots for a 2-layer winding is equal to the number of coils. The number of commutator segments is also the same.

7. The number of parallel paths in the armature = mP where 'm' is the multiplicity of the winding and 'P' the number of poles. Taking the first condition, we have $Y_B = Y_F \pm 2m$ where $m=1$ for simplex lap and $m=2$ for duplex winding etc.
8. If $Y_B > Y_F$ i.e $Y_B = Y_F + 2$, then we get a progressive or right-handed winding i.e a winding which progresses in the clockwise direction as seen from the commutator end. In this case $Y_C = +1$.
9. If $Y_B < Y_F$ i.e $Y_B = Y_F - 2$, then we get a retrogressive or left-handed winding i.e one which advances in the anti-clockwise direction when seen from the commutator side. In this case $Y_C = -1$.
10. Hence, it is obvious that for

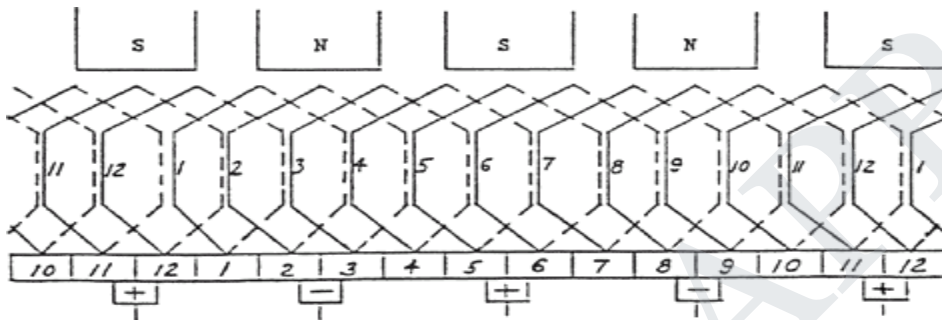

Progressive winding

$$Y_B = \frac{Z}{P} + 1$$

$$Y_F = \frac{Z}{P} - 1$$

Retrogressive winding

$$Y_B = \frac{Z}{P} - 1$$

$$Y_F = \frac{Z}{P} + 1$$

Wave Winding

This type of winding is used in dc generators employed in high-voltage applications. Notice that the two ends of each coil are connected to commutator segments separated by the distance between poles. This configuration allows the series addition of the voltages in all the windings between brushes. This type of winding only requires one pair of brushes. In practice, a practical generator may have several pairs to improve commutation. When the end connections of the coils are spread apart as shown in Figure a wave or series winding is formed. In a wave winding there are only two paths regardless of the number of poles. Therefore, this type winding requires only two brushes but can use as many brushes as poles. Because the winding progresses in one direction round the armature in a series of 'waves' it is known as wave winding. If, after passing once round the armature, the winding falls in a slot to the left of its starting point then winding is said to be retrogressive. If, however, it falls one slot to the right, then it is progressive.

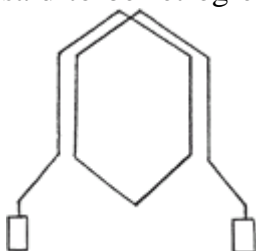

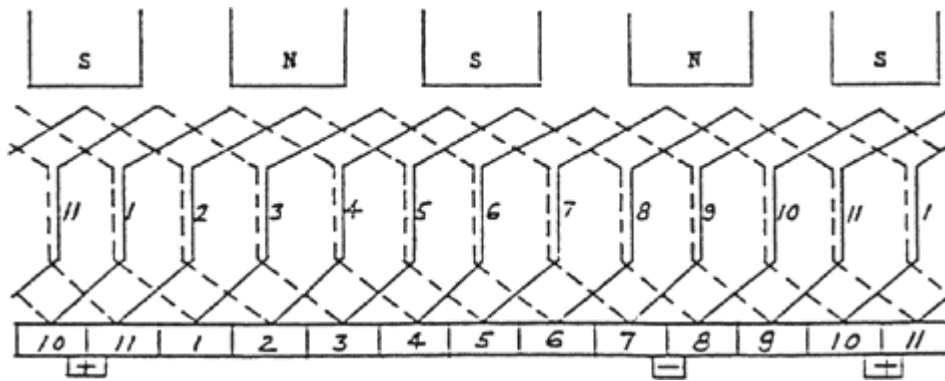

1. YF are odd and of the same sign.
2. Back and front pitches are nearly equal to the pole pitch and may be equal or differ by 2, in which case, they are respectively one more or one less than the average pitch.
3. Resultant pitch $YR = YF + YB$.
4. Commutator pitch, $YC = YA$ (in lap winding $YC = \pm 1$). Also $YC = (\text{No. of commutator bars} \pm 1) / \text{No. of pair of poles}$.
5. The average pitch which must be an integer is given by $YA = (Z \pm 2) / P = (\text{No. of commutator bars} \pm 1) / \text{No. of pair of poles}$.
6. The number of coils i.e NC can be found from the relation $NC = (PYA \pm 2) / 2$.
7. It is obvious from 5 that for a wave winding, the number of armature conductors with 2 either added or subtracted must be a multiple of the number of poles of the generator. This restriction eliminates many even numbers which are unsuitable for this winding.
8. The number of armature parallel paths = $2m$ where 'm' is the multiplicity of the winding.

EMF Equation

Consider a D.C generator whose field coil is excited to produce a flux density distribution along the air gap and the armature is driven by a prime mover at constant speed as shown in figure

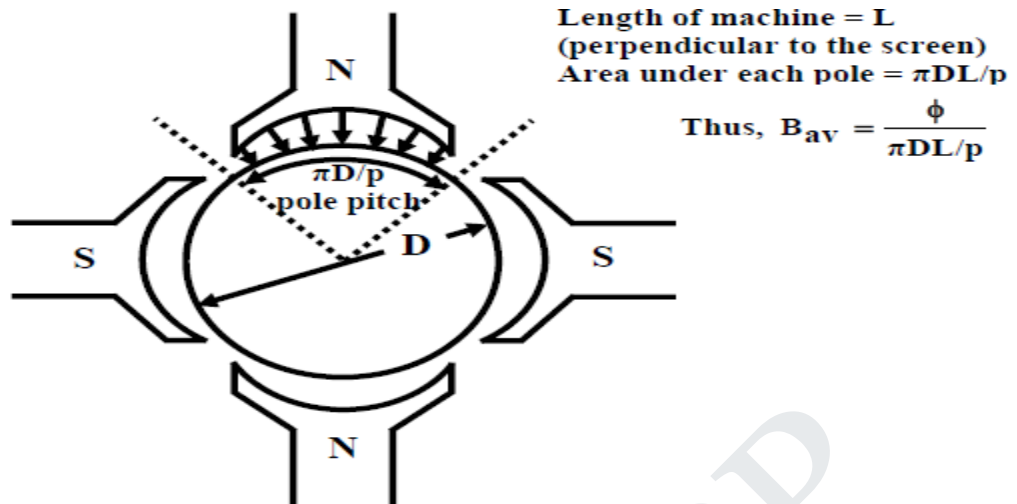

Let us assume a p polar d.c generator is driven (by a prime mover) at n rps. The excitation of the stator field is such that it produces a ϕ Wb flux per pole. Also let z be the total number of armature conductors and a be the number of parallel paths in the armature circuit. In general, as discussed in the earlier section the magnitude of the voltage from one conductor to another is likely to vary since flux density distribution is trapezoidal in nature. Therefore, total average voltage across the brushes is calculated on the basis of average flux density B_{av} . If D and L are the rotor diameter and the length of the machine in meters then area under each pole is $\frac{\pi D L}{p}$. Hence average flux density in the gap is given by

$$\begin{aligned} \text{Average flux density } B_{av} &= \frac{\phi}{\left(\frac{\pi D}{p}\right)L} \\ &= \frac{\phi p}{\pi DL} \end{aligned}$$

$$\text{Induced voltage in a single conductor} = B_{av}Lv$$

$$\text{Number of conductors present in each parallel path} = \frac{z}{a}$$

$$\text{If } v \text{ is the tangential velocity then, } v = \pi Dn$$

$$\begin{aligned} \text{Therefore, total voltage appearing across the brushes} &= \frac{z}{a} B_{av}Lv \\ &= \frac{z}{a} \frac{\phi p}{\pi DL} L \pi Dn \end{aligned}$$

$$\text{Thus voltage induced across the armature, } E_A = \frac{pz}{a} \phi n$$

Armature reaction

In a unloaded d.c machine armature current is vanishingly small and the flux per pole is decided by the field current alone. The uniform distribution of the lines of force get upset when armature too carries current due to loading. In one half of the pole, flux lines are concentrated and in the other half they are

rarefied. Qualitatively one can argue that during loading condition flux per pole will remain same as in no load operation because the increase of flux in one half will be balanced by the decrease in the flux in the other half. Since it is the flux per pole which decides the emf generated and the torque produced by the machine, seemingly there will be no effect felt so far as the performance of the machine is concerned due to armature reaction. This in fact is almost true when the machine is lightly or moderately loaded

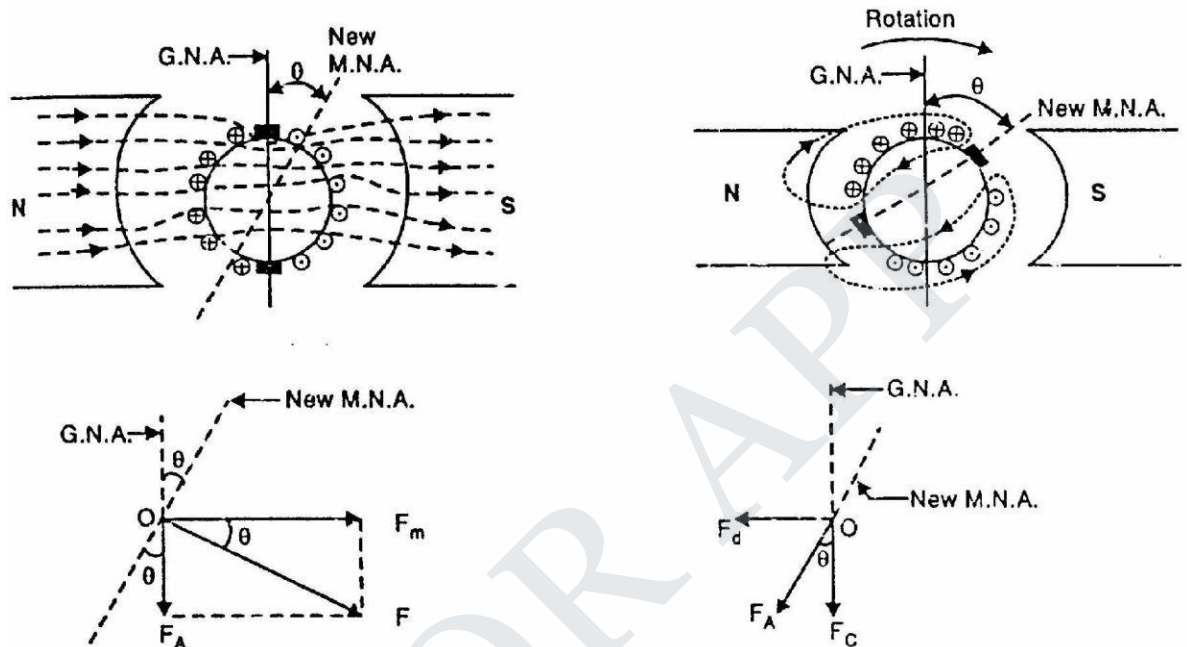

However at rated armature current the increase of flux in one half of the pole is rather less than the decrease in the other half due to presence of *saturation*. In other words there will be a net decrease in flux per pole during sufficient loading of the machine. This will have a direct bearing on the emf as well as torque developed affecting the performance of the machine.

Apart from this, due to distortion in the flux distribution, there will be some amount of flux present along the q-axis (brush axis) of the machine. This causes commutation difficult. In the following sections we try to explain armature reaction in somewhat detail considering motor and generator mode separately.

Methods Of Excitation

Various methods of excitation of the field windings are

Separately-excited generators

- Self-excited generators: series generators, shunt generators, compound generators
- With self-excited generators, residual magnetism must be present in the machine iron to get the self-excitation process started.
- The relation between the steady-state generated emf E_a and the armature terminal voltage V_a is $V_a = E_a - I_a R_a$

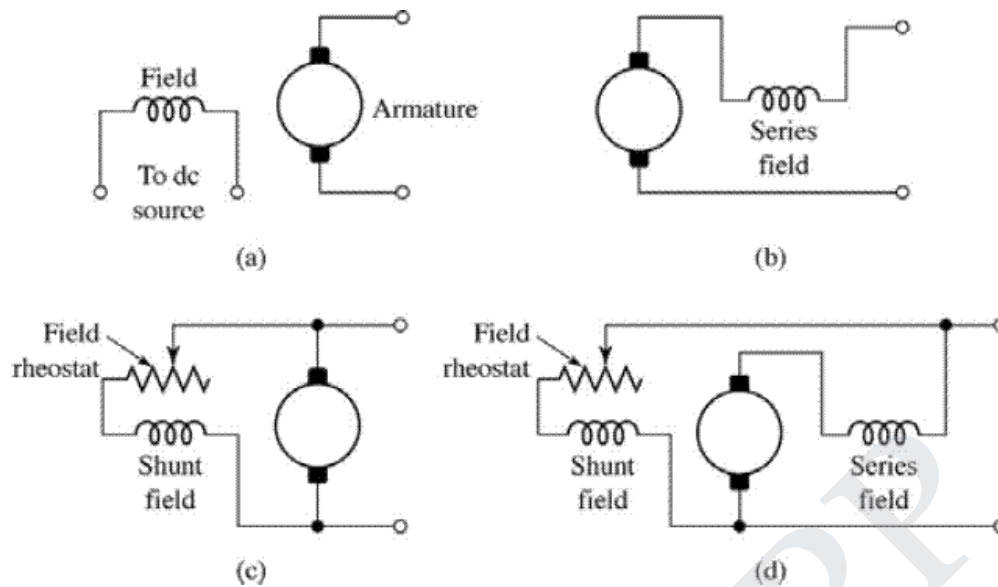

Figure.5.3 Methods of Excitation

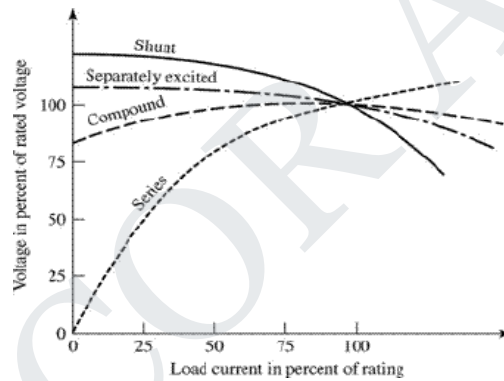

Figure.5.4 Load Curve

Typical steady-state dc-motor speed-torque characteristics are shown in Figure.1.4, in which it is assumed that the motor terminals are supplied from a constant-voltage source.

In a motor the relation between the emf E_a generated in the armature and the armature terminal voltage $V_a = E_a + I_a R_a$. The application of dc machines lie in the variety of performance characteristics offered by the possibilities of shunt, series, and compound excitation.

Commutation And Interpoles

In larger machines the commutation process would involve too much sparking, which causes brush wear, noxious gases (ozone) that promote corrosion, etc. In these cases it is common to use separate commutation interpoles. These are separate, usually narrow or seemingly vestigial pole pieces which carry armature current. They are arranged in such a way that the flux from the interpole drives current in the commutated coil in the proper direction

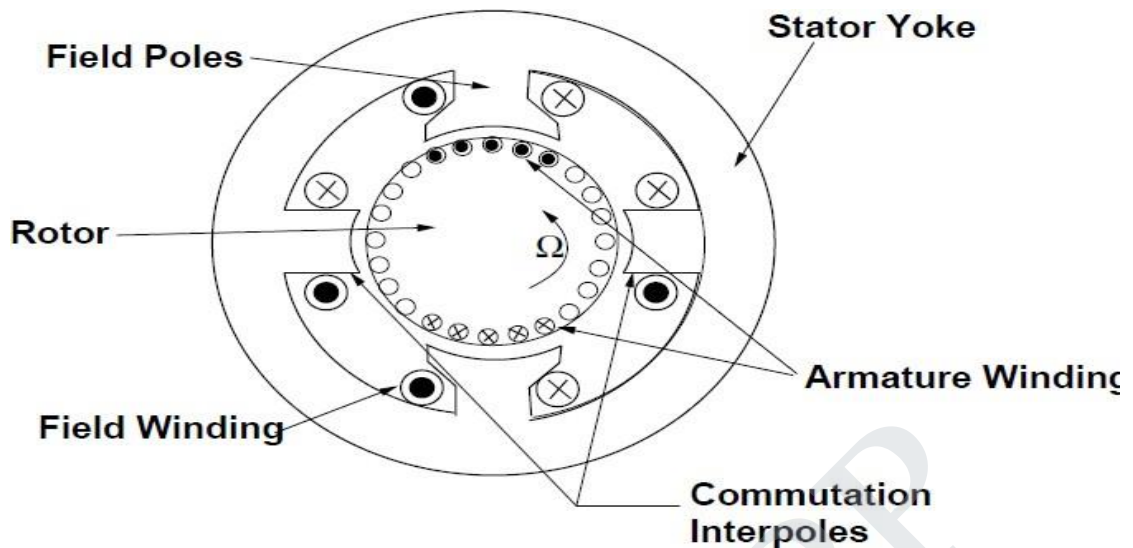

Remember that the coil being commutated is located physically between the active poles and the interpole is therefore in the right spot to influence commutation. The interpole is wound with armature current (it is in series with the main brushes). It is easy to see that the interpole must have a flux density proportional to the current to be commutated. Since the speed with which the coil must be commutated is proportional to rotational velocity and so is the voltage induced by the interpole, if the right numbers of turns are put around the interpole, commutation can be made to be quite accurate.

Generator Characteristics

The three most important characteristics or curves of a D.C generator are:

Open Circuit Characteristic (O.C.C.)

This curve shows the relation between the generated emf. at no-load (E_0) and the field current (I_f) at constant speed. It is also known as magnetic characteristic or no-load saturation curve. Its shape is practically the same for all generators whether separately or self-excited. The data for O.C.C. curve are obtained experimentally by operating the generator at no load and constant speed and recording the change in terminal voltage as the field current is varied.

Internal or Total characteristic (E/I_a)

This curve shows the relation between the generated emf. On load (E) and the armature current (I_a). The emf E is less than E_0 due to the demagnetizing effect of armature reaction. Therefore, this curve will lie below the open circuit characteristic (O.C.C.) It cannot be obtained directly by experiment. It is because a voltmeter cannot read the emf. Generated on load due to the voltage drop in armature resistance. The internal characteristic can be obtained from external characteristic if winding resistances are known because armature reaction effect is included in both characteristics.

External Characteristic (V/IL)

This curve shows the relation between the terminal voltage (V) and load current (IL). The terminal voltage V will be less than E due to voltage drop in the armature circuit. Therefore, this curve will lie below the internal characteristic. This characteristic is very important in determining the suitability of a generator for a given purpose. It can be obtained by making simultaneous.

No-load Saturation Characteristic (E_0/I_f)

It is also known as magnetic characteristic or open circuit Characteristic (*O.C.C*). It shows the relation between the no-load generated emf in armature, E_0 and the field or exciting current I_f at a given fixed speed. It is just demagnetization curve for the material of the electromagnets. Its shape is practically the same for all generators whether separately-excited or self-excited.

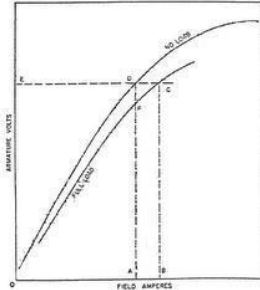

Figure 5.5 Field Vs Armature Curve

A typical no load saturation curve is shown in Figure. It has generator output voltage plotted against field current. The lower straight line portion of the curve represents the air gap because the magnetic parts are not saturated. When the magnetic parts start to saturate, the curve bends over until complete saturation is reached. Then the curve becomes a straight line again.

Separately-Excited Generator

The No-load saturation curve of a separately excited generator will be as shown in the above Figure. It is obvious that when it is increased from its initial small value, the flux and hence generated emf .E.g. increase directly as current so long as the poles are unsaturated. This is represented by straight portion in Figure. But as the flux density increases, the poles become saturated, so a greater increase I_f is required to produce a given increase in voltage than on the lower part of the curve. That is why the upper portion of the curve bends.

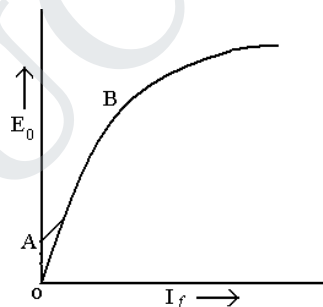

Figure 5.6 Open Circuit Characteristics

The *O.C.C* curve for self-excited generators whether shunt or series wound is shown in above Figure. Due to the residual magnetism in the poles, some emf ($=OA$) is generated even when $I_f = 0$. Hence, the curve starts a little way up. The slight curvature at the lower end is due to magnetic inertia. It is seen that the first part of the curve is practically straight. This is due to fact that at low flux densities reluctance of iron path being negligible, total reluctance is given by the air gap reluctance which is constant. Hence, the flux and consequently, the generated emf is directly proportional to the exciting current. However, at high flux densities, where μ is small, iron path reluctance becomes appreciable and straight relation between E and I_f no longer holds good. In other words, after point B, saturation of pole starts. However, the initial slope

of the curve is determined by air-gap width. O.C.C for higher speed would lie above this curve and for lower speed, would lie below it.

Separately-excited Generator Let us consider a separately-excited generator giving its rated no-load voltage of E_0 for a certain constant field current. If there were no armature reaction and armature voltage drop, then this voltage would have remained constant as shown in Figure by the horizontal line 1. But when the generator is loaded, the voltage falls due to these two causes, thereby giving slightly drooping characteristics. If we subtract from E_0 the values of voltage drops due to armature reaction for different loads, then we get the value of E —the emf actually induced in the armature under load conditions. Curve 2 is plotted in this way and is known as the internal characteristic.

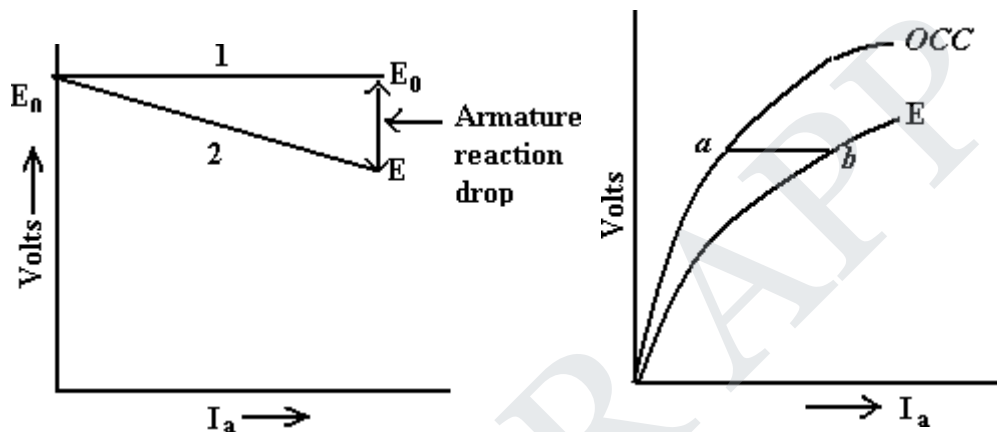

Figure.5.7 Current Vs Voltage

In this generator, because field windings are in series with the armature, they carry full armature current I_a . As I_a is increased, flux and hence generated emf is also increased as shown by the curve. Curve Oa is the O.C.C. The extra exciting current necessary to neutralize the weakening effect of armature reaction at full load is given by the horizontal distance ab . Hence, point b is on the internal characteristic.

External Characteristic (V/I)

It is also referred to as performance characteristic or sometimes voltage-regulating curve. It gives relation between the terminal voltage V and the load current I . This curve lies below the internal characteristic because it takes in to account the voltage drop over the armature circuit resistance. The values of V are obtained by subtracting $I_a R_a$ from corresponding values of E . This characteristic is of great importance in judging the suitability of a generator for a particular purpose. It may be obtained in two ways

- By making simultaneous measurements with a suitable voltmeter and an ammeter on a loaded generator or
- Graphically from the O.C.C provided the armature and field resistances are known and also if the demagnetizing effect or the armature reaction is known.

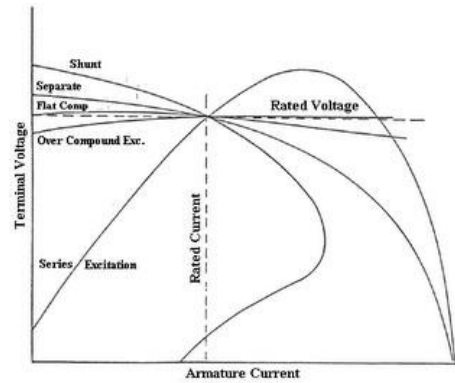

Figure 5.8 Armature Current Vs Terminal Voltage

Figure above shows the external characteristic curves for generators with various types of excitation. If a generator, which is separately excited, is driven at constant speed and has a fixed field current, the output voltage will decrease with increased load current as shown. This decrease is due to the armature resistance and armature reaction effects. If the field flux remained constant, the generated voltage would tend to remain constant and the output voltage would be equal to the generated voltage minus the IR drop of the armature circuit. However, the demagnetizing component of armature reactions tends to decrease the flux, thus adding an additional factor, which decreases the output voltage.

CHAPTER 5 DC MOTORS

D.C. Motor Principle

A machine that converts d.c. power into mechanical power is known as a d.c. motor. Its operation is based on the principle that when a current carrying conductor is placed in a magnetic field, the conductor experiences a mechanical force. The direction of this force is given by Fleming's left hand rule and magnitude is given by;

$$F \propto BI \text{ newtons}$$

Basically, there is no constructional difference between a d.c. motor and a d.c. generator. The same d.c. machine can be run as a generator or motor.

Working of D.C. Motor

When the terminals of the motor are connected to an external source of d.c. supply:

- (i) the field magnets are excited developing alternate N and S poles;
- (ii) the armature conductors carry currents.

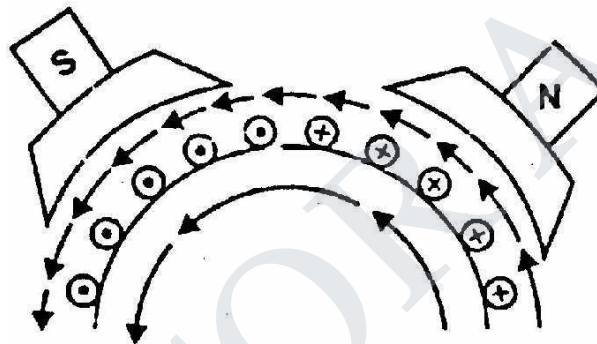

All conductors under N-pole carry currents in one direction while all the conductors under S-pole carry currents in the opposite direction. Suppose the conductors under N-pole carry currents into the plane of the paper and those under S-pole carry currents out of the plane of the paper as shown in Fig. Since each armature conductor is carrying current and is placed in the magnetic field, mechanical force acts on it.

Applying Fleming's left hand rule, it is clear that force on each conductor is tending to rotate the armature in anticlockwise direction. All these forces add together to produce a driving torque which sets the armature rotating. When the conductor moves from one side of a brush to the other, the current in that conductor is reversed and at the same time it comes under the influence of next pole which is of opposite polarity. Consequently, the direction of force on the conductor remains the same.

Types of D.C. Motors

Like generators, there are three types of d.c. motors characterized by the connections of field winding in relation to the armature viz.:

- (i) Shunt-wound motor in which the field winding is connected in parallel with the armature. The current through the shunt field winding is not the same as the armature current. Shunt field windings are designed to produce the necessary m.m.f. by means of a relatively large number of turns of wire having high resistance. Therefore, shunt field current is relatively small compared with the armature current.

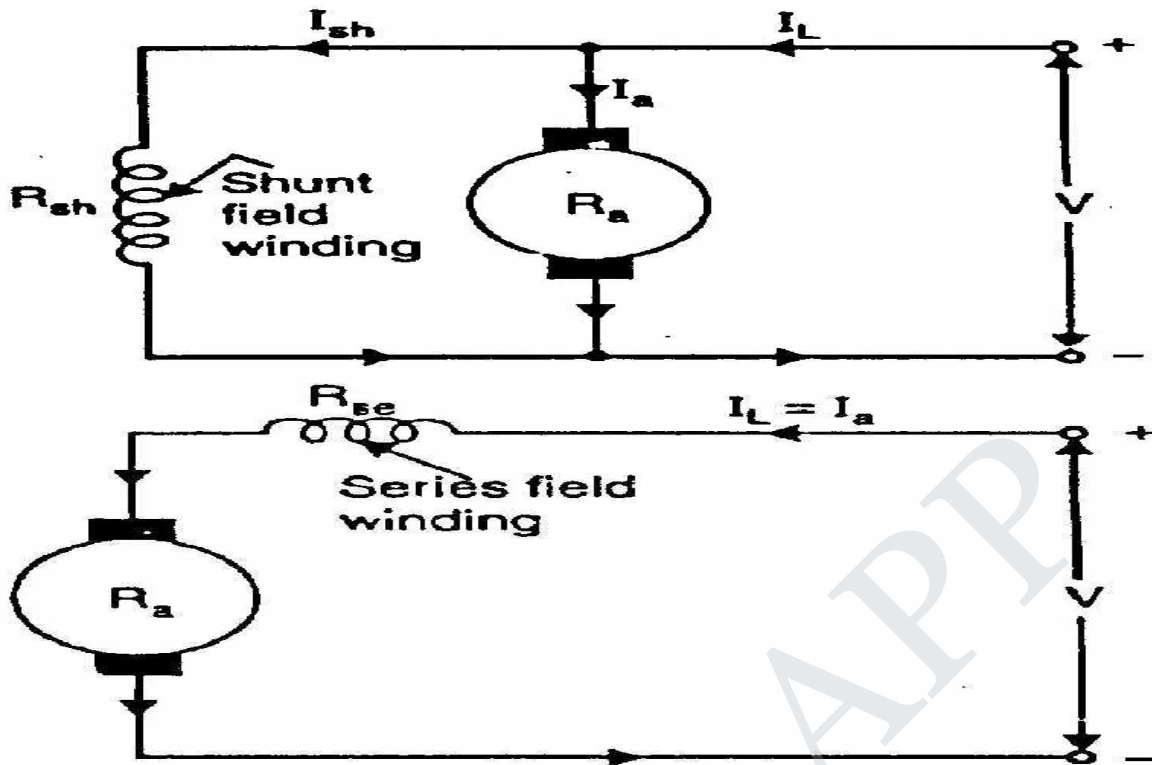

(ii) Series-wound motor in which the field winding is connected in series with the armature. Therefore, series field winding carries the armature current. Since the current passing through a series field winding is the same as the armature current, series field windings must be designed with much fewer turns than shunt field windings for the same m.m.f. Therefore, a series field winding has a relatively small number of turns of thick wire and, therefore, will possess a low resistance.

(iii) Compound-wound motor which has two field windings; one connected in parallel with the armature and the other in series with it. There are two types of compound motor connections (like generators). When the shunt field winding is directly connected across the armature terminals it is called short-shunt connection. When the shunt winding is so connected that it shunts the series combination of armature and series field it is called long-shunt connection.

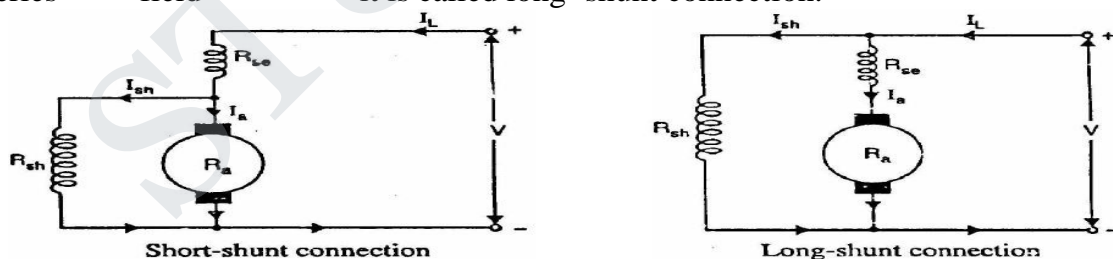

Motor Characteristics Torque/Speed Curves

In order to effectively design with D.C. motors, it is necessary to understand their characteristic curves. For every motor, there is a specific Torque/Speed curve and Power curve.

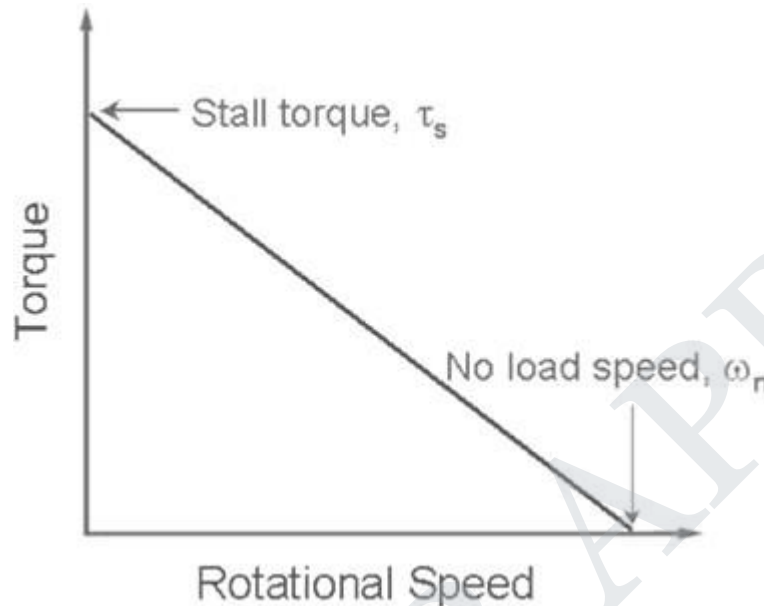

Figure 5.13 Speed Vs Torque Curve

The graph above shows a torque/speed curve of a typical D.C. motor. Note that torque is inversely proportional to the speed of the output shaft. In other words, there is a tradeoff between how much torque a motor delivers, and how fast the output shaft spins. Motor characteristics are frequently given as two points on this graph:

- The stall torque represents the point on the graph at which the torque is a maximum, but the shaft is not rotating.
- The no load speed, is the maximum output speed of the motor (when no torque is applied to the output shaft).
- The linear model of a D.C. motor torque/speed curve is a very good approximation. The torque/speed curves shown below are actual curves for the green maxon motor (pictured at right) used by students in 2.007. One is a plot of empirical data, and the other was plotted mechanically using a device developed at MIT.



Figure 5.14 Maxon Motor

Note that the characteristic torque/speed curve for this motor is quite linear. This is generally true as long as the curve represents the direct output of the motor, or a simple gear reduced output. If the specifications are given as two points, it is safe to assume a linear curve.

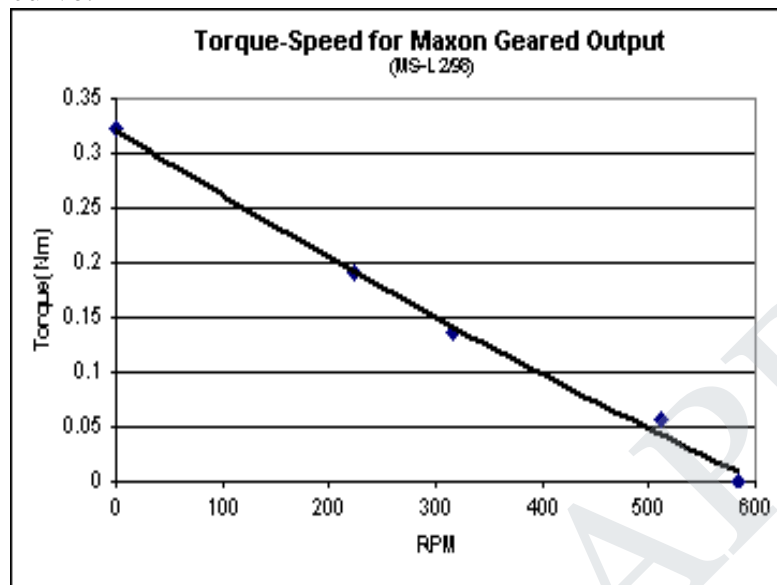

Figure 5.15 Speed Vs Torque Characteristics

Recall that earlier we defined power as the product of torque and angular velocity. This corresponds to the area of a rectangle under the torque/speed curve with one corner at the origin and another corner at a point on the curve. Due to the linear inverse relationship between torque and speed, the maximum power occurs at the point where Recall that earlier we defined power as the product of torque and angular velocity.

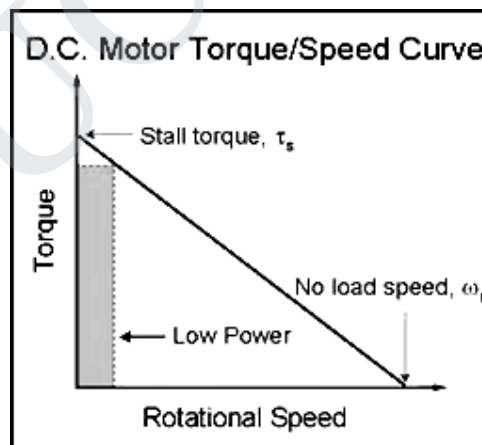

Figure 5.16 Speed Vs Torque Characteristics

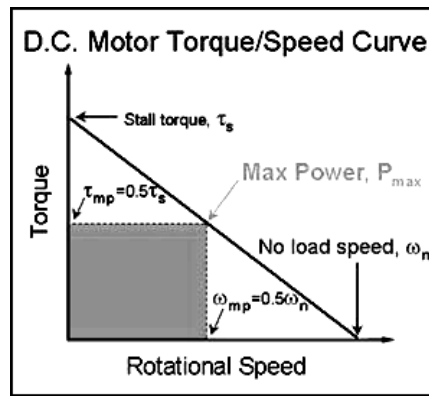

Figure 5.17 Speed Vs Torque Characteristics

This corresponds to the area of a rectangle under the torque/speed curve with one corner at the origin and another corner at a point on the curve, and $\omega = \frac{1}{2} \omega_n$.

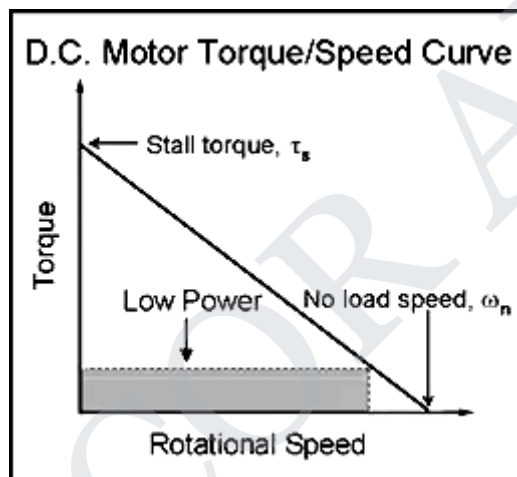

Figure 5.18 Speed Vs Torque Characteristics

Power/Torque And Power/Speed Curves

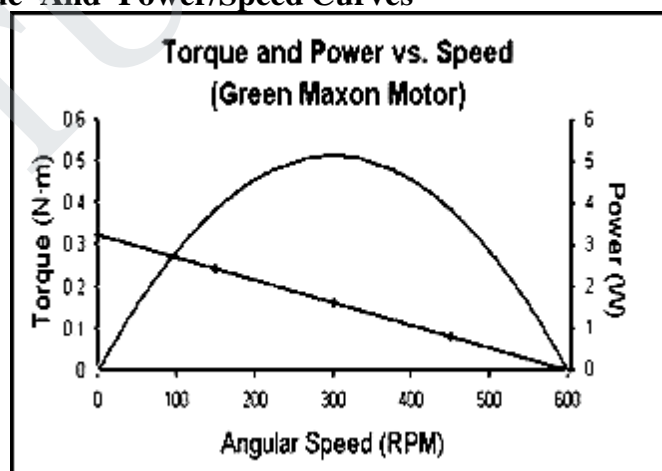

Figure 5.19 Power Vs Torque Curve

Speed Control Of Dc Shunt Motor

We know that the speed of shunt motor is given by:

Where, V_a is the voltage applied across the armature,

N is the rotor speed and ϕ is the flux per pole and is proportional to the field current I_f . As explained earlier, armature current I_a is decided by the mechanical load present on the shaft. Therefore, by varying V_a and I_f we can vary n . For fixed supply voltage and the motor connected as shunt we can vary V_a by controlling an external resistance connected in series with the armature. I_f of course can be varied by controlling external field resistance R_f connected with the field circuit. Thus for shunt motor we have essentially two methods for controlling speed, namely by:

1. Varying Armature Resistance
2. Varying Field Resistance

Speed Control by Varying Armature Resistance

The inherent armature resistance R_a being small, speed n versus armature current (I_a) characteristic will be a straight line with a small negative slope as shown in figure.

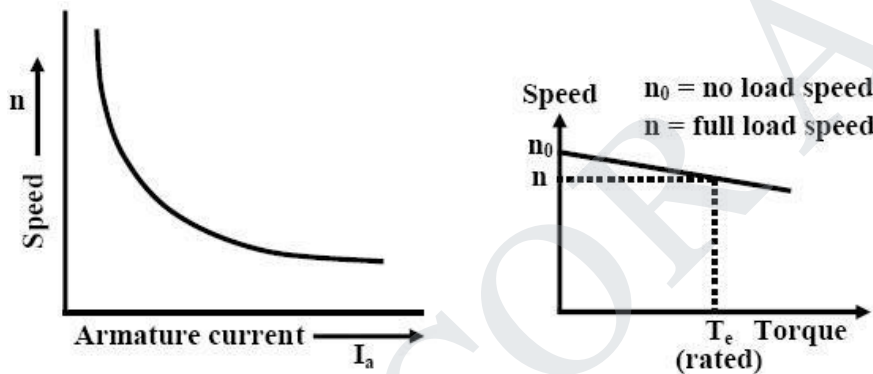

Figure 5.20(i) Speed Vs Armature Current. (ii) Speed Vs Torque Characteristics

Note that for shunt motor voltage applied to the field and armature circuit are same and equal to the supply voltage V . However, as the motor is loaded, $I_a R_a$ drop increases making speed a little less than the no load speed n_0 . For a well designed shunt motor this drop in speed is small and about 3 to 5% with respect to no load speed. This drop in speed from no load to full load condition expressed as a percentage of no load speed is called the inherent speed regulation of the motor. It is for this reason, a d.c shunt motor is said to be practically a constant speed motor since speed drops by a small amount from no load to full load condition.

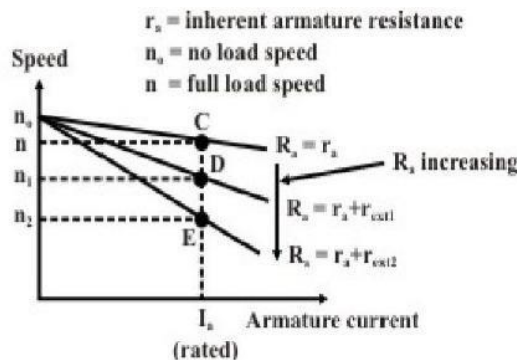

Figure 5.21 Speed Vs Armature Current Characteristics

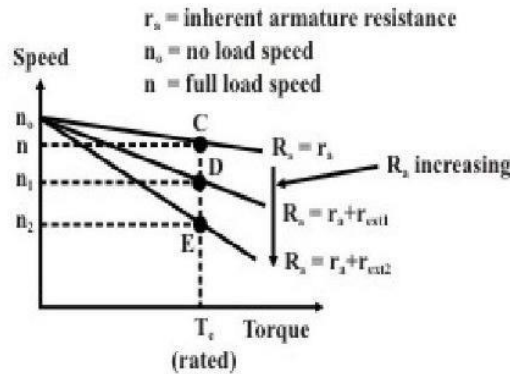

Figure 5.22 Speed Vs Torque Characteristics

From these characteristic it can be explained how speed control is achieved. Let us assume that the load torque T_L is constant and field current is also kept constant. Therefore, since steady state operation demands $T_e = T_L$, $T_e = kI_a\phi$ too will remain constant; which means I_a will not change. Suppose $R_{ext} = 0$, then at rated load torque, operating point will be at C and motor speed will be n . If additional resistance r_{ext1} is introduced in the armature circuit, new steady state operating speed will be n_1 corresponding to the operating point D.

This same load torque is supplied at various speed. Variation of the speed is smooth and speed will decrease smoothly if R_{ext} is increased. Obviously, this method is suitable for controlling speed below the base speed and for supplying constant rated load torque which ensures rated armature current always. Although, this method provides smooth wide range speed control (from base speed down to zero speed), has a serious drawback since energy loss takes place in the external resistance R_{ext} reducing the efficiency of the motor.

Speed Control by Varying Field Current

In this method field circuit resistance is varied to control the speed of a dc shunt motor. Let us rewrite the basic equation to understand the method.

If flux ϕ will change, hence speed will vary. To change If an external resistance is connected in series with the field windings. The field coil produces rated flux when no external resistance is connected and rated voltage is applied across field coil. It should be understood that we can only decrease flux from its rated value by adding external resistance. Thus the speed of the motor will rise as we decrease the field current and speed control above the base speed will be achieved. Speed versus armature current characteristic is shown in figure for two flux values ϕ and ϕ_1 . Since $\phi_1 < \phi$, the no load speed n_0' for flux value ϕ_1 is more than the no load speed n_0 corresponding to ϕ .

However, this method will not be suitable for constant load torque. To make this point clear, let us assume that the load torque is constant at rated value. So from the initial steady condition, we have $T_L \text{ rated} = T_{a1} = kI_{a1}\phi$. If load torque remains constant and flux is reduced to ϕ_1 , new armature current in the steady state is obtained from $kI_{a1}\phi_1 = T_L \text{ rated}$. Therefore new armature current is but this fraction is less than 1. Hence new armature current will be greater than the rated armature current and the motor will be overloaded. This method therefore, will be suitable for a load whose torque demand decreases with the rise in speed keeping the output power constant as shown in figure. Obviously this method is based on flux weakening of the main field.

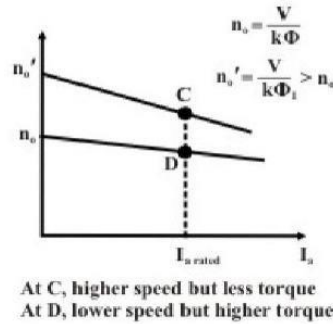

Figure 5.23 Speed Vs Armature Current Characteristics

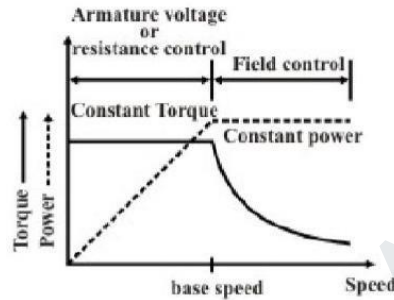

Figure 5.24 Constant Torque and Power Operation

Starting Of Dc Motors

The speed of the machine has to be increased from zero and brought to the operating speed. This is called starting of the motor. The operating speed itself should be varied as per the requirements of the load. This is called speed control. Finally, the running machine has to be brought to rest, by decelerating the same. This is called braking.

At the instant of starting, rotor speed $n = 0$, hence starting armature current is $I_{st} = V/ra$. Since, armature resistance is quite small, starting current may be quite high (many times larger than the rated current). A large machine, characterized by large rotor inertia (J), will pick up speed rather slowly. Thus the level of high starting current may be maintained for quite some time so as to cause serious damage to the brush/commutator and to the armature winding. Also the source should be capable of supplying this burst of large current. The other loads already connected to the same source, would experience a dip in the terminal voltage, every time a D.C motor is attempted to start with full voltage. This dip in supply voltage is caused due to sudden rise in voltage drop in the source's internal resistance. The duration for which this drop in voltage will persist once again depends on inertia of the motor. Hence, for small D.C motors extra precaution may not be necessary during starting as large starting current will very quickly die down because of fast rise in the back emf. However, for large motor, a starter is to be used during starting.

A simple starter to limit the starting current, a suitable external resistance R is connected in series, as shown in the figure, with the armature so that $I_{st} = V/(R+ra)$ At the time of starting, to have sufficient starting torque, field current is maximized by keeping external field resistance R_f to zero value. As the motor picks up speed, the value of R is gradually decreased to zero so that during running no external resistance remains in the armature circuit. But each time one has to restart the motor, the external armature resistance must be set to maximum value by moving the jockey manually. Now if the supply goes off, motor will come to a stop. All on a sudden, let us imagine, supply is restored. This is then nothing but full voltage starting. In other words, one should be constantly alert to set the resistance to maximum value

whenever the motor comes to a stop. This is one major limitation of a simple rheostatic starter.

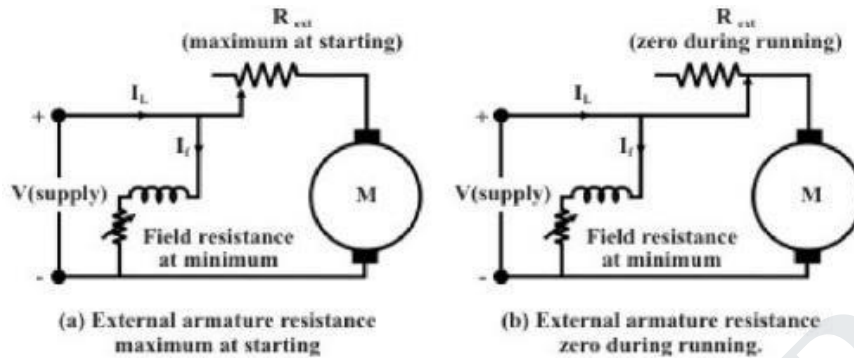

Figure 1.25 Starting Using External Resistance

Three Point Starter

A “3-point starter” is extensively used to start a D.C shunt motor. It not only overcomes the difficulty of a plain resistance starter, but also provides additional protective features such as over load protection and no volt protection. The diagram of a 3-point starter connected to a shunt motor is shown in figure. Although, the circuit looks a bit clumsy at a first glance, the basic working principle is same as that of plain resistance starter. The starter is shown enclosed within the dotted rectangular box having three terminals marked as A, L and F for external connections. Terminal A is connected to one armature terminal A1 of the motor. Terminal F is connected to one field terminal F1 of the motor and terminal L is connected to one supply terminal as shown. F2 terminal of field coil is connected to A2 through an external variable field resistance and the common point connected to supply (-ve). The external armatures resistances consist of several resistances connected in series and are shown in the form of an arc. The junctions of the resistances are brought out as terminals and marked. Just beneath the resistances, a continuous copper strip also in the form of an arc is present.

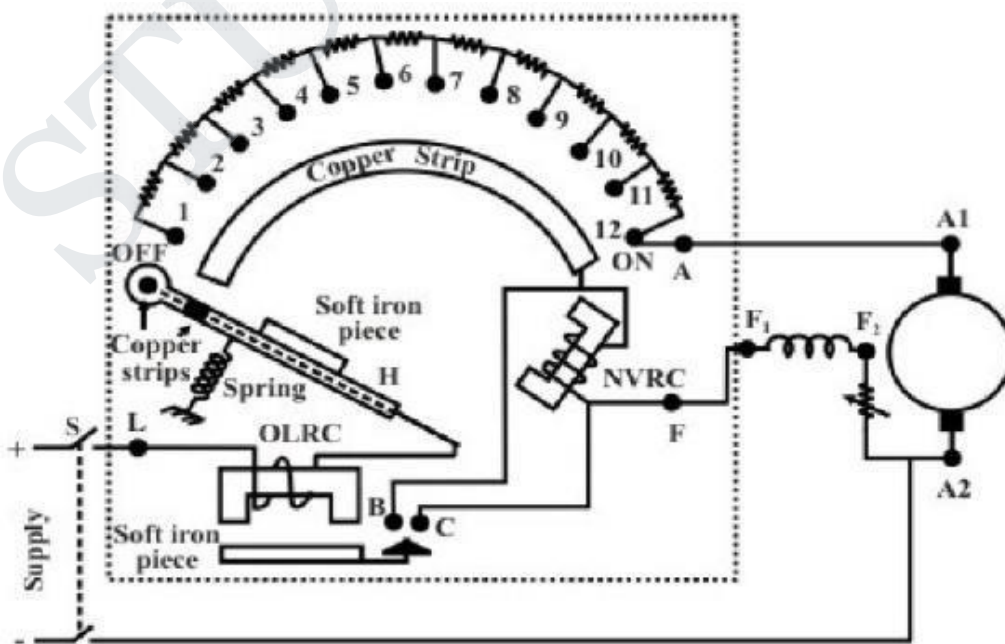

Figure 5.26 Three Point Starter

There is a handle which can be moved in the clockwise direction against the spring tension. The spring tension keeps the handle in the OFF position when no one attempts to move it. Now let us trace the circuit from terminal L (supply + ve). The wire from L passes through a small electro magnet called OLRC, (the function of which we shall discuss a little later) and enters through the handle shown by dashed lines. Near the end of the handle two copper strips are firmly connected with the wire.

The furthest strip is shown circular shaped and the other strip is shown to be rectangular. When the handle is moved to the right, the circular strip of the handle will make contacts with resistance terminals 1, 2 etc. Progressively. On the other hand, the rectangular strip will make contact with the continuous arc copper strip. The other end of this strip is brought as terminal F after going through an electromagnet coil (called NVRC). Terminal F is finally connected to motor field terminal Fl.

Working principle

In the operation of the starter, initially the handle is in the OFF position. Neither armature nor the field of the motor gets supply. Now the handle is moved to stud number 1. In this position armature and all the resistances in series gets connected to the supply. Field coil gets full supply as the rectangular strip makes contact with arc copper strip. As the machine picks up speed handle is moved further to stud number 2. In this position the external resistance in the armature circuit is less as the first resistance is left out. Field however, continues to get full voltage by virtue of the continuous arc strip. Continuing in this way, all resistances will be left out when stud number 12 (ON) is reached. In this position, the electromagnet (NVRC) will attract the soft iron piece attached to the handle. Even if the operator removes his hand from the handle, it will still remain in the ON position as spring restoring force will be balanced by the force of attraction between NVRC and the soft iron piece of the handle. The no volt release coil (NVRC) carries same current as that of the field coil. In case supply voltage goes off, field coil current will decrease to zero. Hence NVRC will be de-energized and will not be able to exert any force on the soft iron piece of the handle. Restoring force of the spring will bring the handle back in the OFF position.

The starter also provides over load protection for the motor. The other electromagnet, OLRC overload release coil along with a soft iron piece kept under it, is used to achieve this. The current flowing through OLRC is the line current I_L drawn by the motor. As the motor is loaded, I_a hence I_L increases. Therefore, I_L is a measure of loading of the motor. Suppose we want that the motor should not be over loaded beyond rated current. Now gap between the electromagnet and the soft iron piece is so adjusted that for $I_L \leq I_{rated}$ the iron piece will not be pulled up. However, if $I_L > I_{rated}$ force of attraction will be sufficient to pull up iron piece. This upward movement of the iron piece of OLRC is utilized to de-energize NVRC. To the iron a copper strip is attached. During over loading condition, this copper strip will also move up and put a short circuit between two terminals B and C. Carefully note that B and C are nothing but the two ends of the NVRC. In other words, when over load occurs a short circuit path is created across the NVRC. Hence NVRC will not carry any current now and gets deenergized. The moment it gets deenergised, spring action will bring the handle in the OFF position thereby disconnecting the motor from the supply. Three point starter has one disadvantage. If we want to run the machine at

higher speed (above rated speed) by field weakening (i.e., by reducing field current), the strength of NVRC magnet may become so weak that it will fail to hold the handle in the ON position and the spring action will bring it back in the OFF position. Thus we find that a false disconnection of the motor takes place even when there is neither over load nor any sudden disruption of supply.

Four-Point Starter

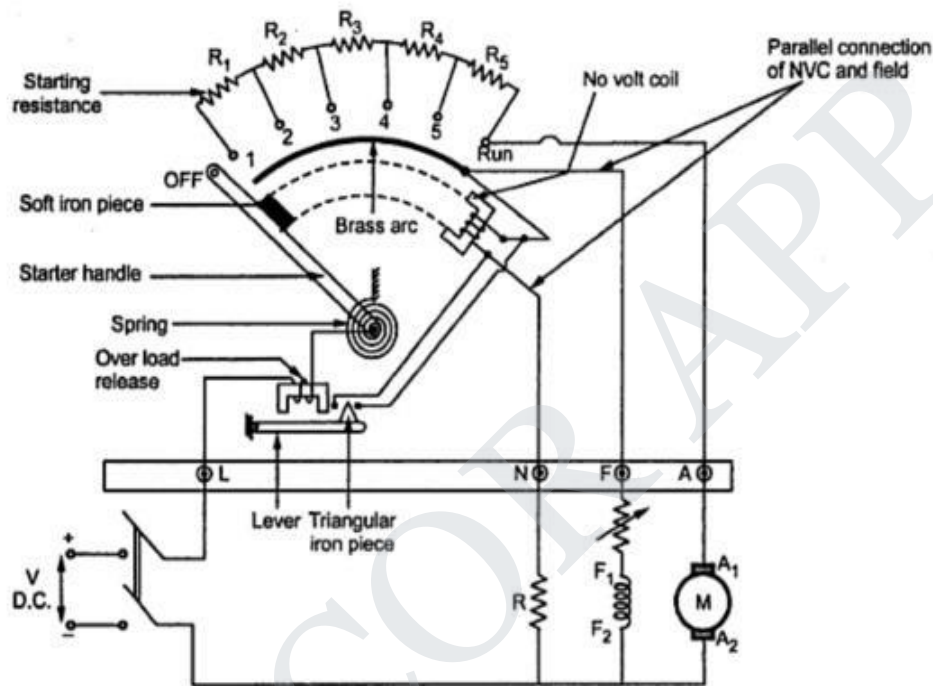

Figure 5.27 Four point starter

The four-point starter eliminates the drawback of the three-point starter. In addition to the same three points that were in use with the three-point starter, the other side of the line, L1, is the fourth point brought to the starter when the arm is moved from the "Off" position. The coil of the holding magnet is connected across the line. The holding magnet and starting resistors function identical as in the three-point starter.

The possibility of accidentally opening the field circuit is quite remote. The four-point starter provides the no-voltage protection to the motor. If the power fails, the motor is disconnected from the line.

Swinburne's Test

- For a d.c shunt motor change of speed from no load to full load is quite small. Therefore, mechanical loss can be assumed to remain same from no load to full load. Also if field current is held constant during loading, the core loss too can be assumed to remain same.
- In this test, the motor is run at rated speed under *no load* condition at rated voltage. The current drawn from the supply I_{L0} and the field current I_f are recorded (figure 40.3). Now we note that:

$$\begin{aligned}
 \text{Input power to the motor, } P_{in} &= VI_{L0} \\
 \text{Cu loss in the field circuit } P_{fl} &= VI_f \\
 \text{Power input to the armature,} &= VI_{L0} - VI_f \\
 &= V(I_{L0} - I_f) \\
 &= VI_{a0} \\
 \text{Cu loss in the armature circuit} &= I_{a0}^2 r_a \\
 \text{Gross power developed by armature} &= VI_{a0} - I_{a0}^2 r_a \\
 &= (V - I_{a0} r_a) I_{a0} \\
 &= E_{b0} I_{a0}
 \end{aligned}$$

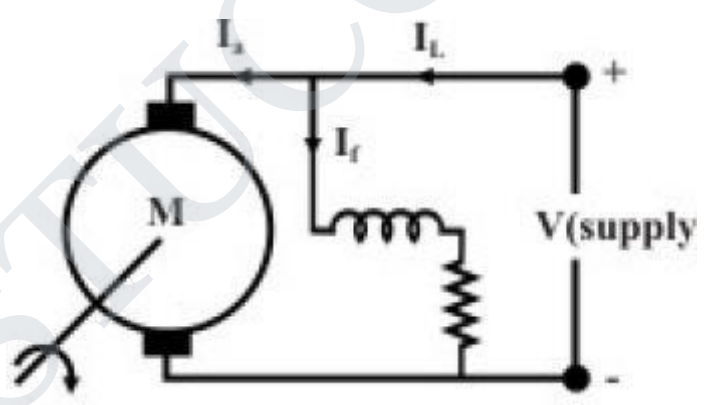
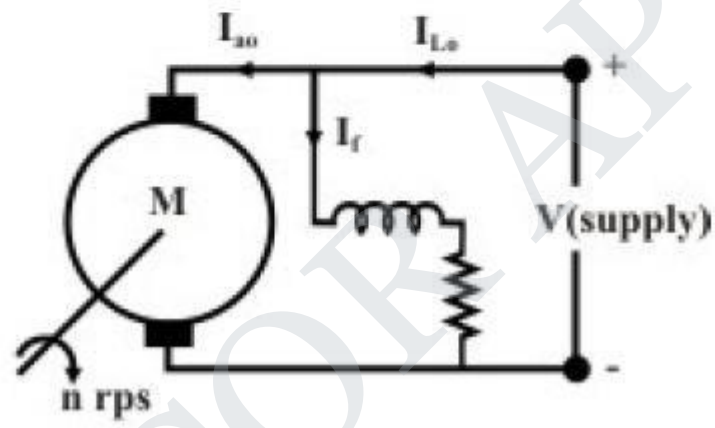

- Since the motor is operating under no load condition, net mechanical output power is zero. Hence the gross power developed by the armature must supply the core loss and friction & windage losses of the motor. Therefore,

$$P_{core} + P_{friction} = (V - I_{a0} r_a) I_{a0} = E_{b0} I_{a0}$$

- Since, both P_{core} and $P_{friction}$ for a shunt motor remains practically constant from no load to full load, the sum of these losses is called constant rotational loss i.e.,

$$\text{constant rotational loss, } P_{rot} = P_{core} + P_{friction}$$

- In the Swinburne's test, the constant rotational loss comprising of core and friction loss is estimated from the above equation.
- After knowing the value of P_{rot} from the Swinburne's test, we can fairly estimate the efficiency of the motor at any loading condition. Let the motor be loaded such that new current drawn from the supply is I_L and the new armature current is I_a as shown in figure 40.4. To estimate the efficiency of the loaded motor we proceed as follows:

$$\begin{aligned}
 \text{Input power to the motor, } P_{in} &= VI_L \\
 \text{Cu loss in the field circuit } P_{fl} &= VI_f \\
 \text{Power input to the armature,} &= VI_L - VI_f \\
 &= V(I_L - I_f) \\
 &= VI_a \\
 \text{Cu loss in the armature circuit} &= I_a^2 r_a \\
 \text{Gross power developed by armature} &= VI_a - I_a^2 r_a \\
 &= (V - I_a r_a) I_a \\
 &= E_b I_a \\
 \text{Net mechanical output power, } P_{net\ mech} &= E_b I_a - P_{rot} \\
 \therefore \text{ efficiency of the loaded motor, } \eta &= \frac{E_b I_a - P_{rot}}{VI_L} \\
 &= \frac{P_{net\ mech}}{P_{in}}
 \end{aligned}$$

- The estimated value of P_{rot} obtained from Swinburne's test can also be used to estimate the efficiency of the shunt machine operating as a generator. In figure 40.5 is shown to deliver a
- load current I_L to a load resistor R_L . In this case output power being known, it is easier to add the losses to estimate the input mechanical power.

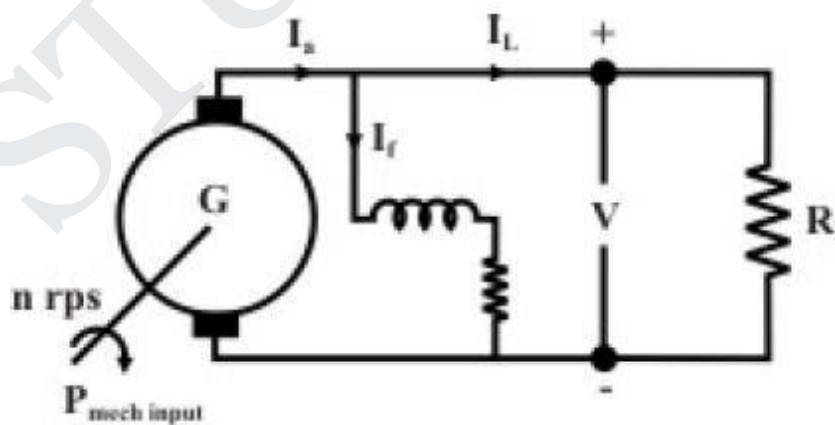

$$\begin{aligned}
 \text{Output power of the generator, } P_{out} &= VI_L \\
 \text{Cu loss in the field circuit } P_{fl} &= VI_f \\
 \text{Output power of the armature,} &= VI_L + VI_f \\
 &= VI_a \\
 \text{Mechanical input power, } P_{in\ mech} &= VI_a + I_a^2 r_a + P_{rot} \\
 \therefore \text{Efficiency of the generator, } \eta &= \frac{VI_L}{P_{in\ mech}} \\
 &= \frac{VI_L}{VI_a + I_a^2 r_a + P_{rot}}
 \end{aligned}$$

- The biggest advantage of Swinburne's test is that the shunt machine is to be run as motor under *no load* condition requiring little power to be drawn from the supply; based on the no load reading, efficiency can be predicted for any load current. However, this test is not sufficient if we want to know more about its performance (effect of armature reaction, temperature rise, commutation etc.) when it is actually loaded. Obviously the solution is to load the machine by connecting mechanical load directly on the shaft for motor or by connecting loading rheostat across the terminals for generator operation. This although sounds simple but difficult to implement in the laboratory for high rating machines (say above 20 kW), Thus the laboratory must have proper supply to deliver such a large power corresponding to the rating of the machine. Secondly, one should have loads to absorb this power.

Hopkinson's test

- This as an elegant method of testing d.c machines. Here it will be shown that while power drawn from the supply only corresponds to no load losses of the machines, the armature physically carries any amount of current (which can be controlled with ease). Such a scenario can be created using two similar mechanically coupled shunt machines. Electrically these two machines are eventually connected in parallel and controlled in such a way that one machine acts as a generator and the other as motor. In other words two similar machines are required to carry out this testing which is not a bad proposition for manufacturer as large numbers of similar machines are manufactured.

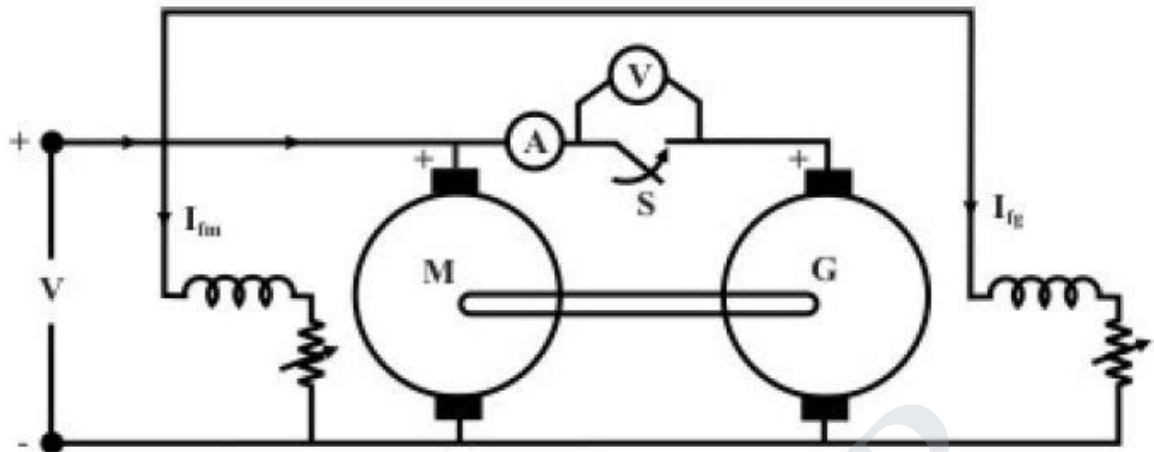

Procedure

- Connect the two similar (same rating) coupled machines as shown in figure 40.6. With switch S opened, the first machine is run as a shunt motor at rated speed. It may be noted that the second machine is operating as a separately excited generator because its field winding is excited and it is driven by the first machine. Now the question is what will be the reading of the voltmeter connected across the opened switch S? The reading may be (i) either close to twice supply voltage or (ii) small voltage. In fact the voltmeter practically reads the difference of the induced voltages in the armature of the machines. The upper armature terminal of the generator may have either +ve or negative polarity. If it happens to be +ve, then voltmeter reading will be small otherwise it will be almost double the supply voltage
- Since the goal is to connect the two machines in parallel, we must first ensure voltmeter reading is small. In case we find voltmeter reading is high, we should switch off the supply, reverse the armature connection of the generator and start afresh. Now voltmeter is found to read small although time is still not ripe enough to close S for paralleling the machines. Any attempt to close the switch may result into large circulating current as the armature resistances are small. Now by adjusting the field current I_{fg} of the generator the voltmeter reading may be adjusted to zero ($E_g \approx E_b$) and S is now closed. Both the machines are now connected in parallel

Loading the machines

After the machines are successfully connected in parallel, we go for loading the machines i.e., increasing the armature currents. Just after paralleling the ammeter reading A will be close to zero as $E_g \approx E_b$. Now if I_{fg} is increased (by decreasing R_{fg}), then E_g becomes greater than E_b and both I_{ag} and I_{am} increase. Thus by increasing field current of generator (alternatively decreasing field current of motor) one can make $E_g > E_b$ so as to make the second machine act as generator and first machine as motor. In practice, it is also required to control the field current of the motor I_{fm} to maintain speed constant at rated value. The interesting point to be noted here is that I_{ag} and I_{am} do not reflect in the supply side line. Thus current drawn from supply remains small (corresponding to losses of both the machines). The loading is sustained by the output power of the generator running

the motor and vice versa. The machines can be loaded to full load current without the need of any loading arrangement

• **Calculation of efficiency**

Let field currents of the machines be are so adjusted that the second machine is acting as generator with armature current I_{ag} and the first machine is acting as motor with armature current I_{am} as shown in figure 40.7. Also let us assume the current drawn from the supply be I_1 . Total power drawn from supply is VI_1 which goes to supply all the losses (namely Cu losses in armature & field and rotational losses) of both the machines

$$\begin{aligned} \text{Power drawn from supply} &= VI_1 \\ \text{Field Cu loss for motor} &= VI_{fm} \\ \text{Field Cu loss for generator} &= VI_{fg} \\ \text{Armature Cu loss for motor} &= I_{am}^2 r_{am} \\ \text{Armature Cu loss for generator} &= I_{ag}^2 r_{ag} \\ \therefore \text{Rotational losses of both the machines} &= VI_1 - (VI_{fm} + VI_{fg} + I_{am}^2 r_{am} + I_{ag}^2 r_{ag}) \end{aligned}$$

Since speed of both the machines are same, it is reasonable to assume the rotational losses of both the machines are equal; which is strictly not correct as the field current of the generator will be a bit more than the field current of the motor, Thus, Once P_{rot} is estimated for each machine we can proceed to calculate the efficiency of the machines as follows,

$$\text{Rotational loss of each machine, } P_{rot} = \frac{VI_1 - (VI_{fm} + VI_{fg} + I_{am}^2 r_{am} + I_{ag}^2 r_{ag})}{2}$$

Efficiency of the motor

- As pointed out earlier, for efficiency calculation of motor, first calculate the input power and then subtract the losses to get the output mechanical power as shown below,

$$\begin{aligned} \text{Total power input to the motor} &= \text{power input to its field} + \text{power input to its armature} \\ P_{inm} &= VI_{fm} + VI_{am} \\ \text{Losses of the motor} &= VI_{fm} + I_{am}^2 r_{am} + P_{rot} \\ \text{Net mechanical output power } P_{outm} &= P_{inm} - (VI_{fm} + I_{am}^2 r_{am} + P_{rot}) \\ \therefore \eta_m &= \frac{P_{outm}}{P_{inm}} \end{aligned}$$

EFFICIENCY OF GENERATOR

$$\text{Losses of the generator} = VI_{fg} + I_{ag}^2 r_{ag} + P_{rot}$$

$$\text{Input power to the generator, } P_{ing} = P_{outg} + (VI_{fg} + I_{ag}^2 r_{ag} + P_{rot})$$

$$\therefore \eta_g = \frac{P_{outg}}{P_{ing}}$$

Advantages of Hopkinson's Test

- The merits of this test are...
 1. This test requires very small power compared to full-load power of the motor-generator coupled system. That is why it is economical.
 2. Temperature rise and commutation can be observed and maintained in the limit because this test is done under full load condition.
 3. Change in iron loss due to flux distortion can be taken into account due to the advantage of its full load condition

Disadvantages of Hopkinson's Test

- The demerits of this test are
 1. It is difficult to find two identical machines needed for Hopkinson's test.
 2. Both machines cannot be loaded equally all the time.
 3. It is not possible to get separate iron losses for the two machines though they are different because of their excitations.
 4. It is difficult to operate the machines at rated speed because field currents vary widely.
- 39.8 Braking of d.c shunt motor: basic idea
- It is often necessary in many applications to stop a running motor rather quickly. We know that any moving or rotating object acquires kinetic energy. Therefore, how fast we can bring the object to rest will depend essentially upon how quickly we can extract its kinetic energy and make arrangement to dissipate that energy somewhere else. If you stop pedaling your bicycle, it will eventually come to a stop eventually after moving quite some distance. The initial kinetic energy stored, in this case dissipates as heat in the friction of the road. However, to make the stopping faster, brake is applied with the help of rubber brake shoes on the rim of the wheels. Thus stored K.E now gets two ways of getting dissipated, one at the wheel-brake shoe interface (where most of the energy is dissipated) and the other at the road-tier interface. This is a good method no doubt, but regular maintenance of brake shoes due to wear and tear is necessary.
- If a motor is simply disconnected from supply it will eventually come to stop no doubt, but will take longer time particularly for large motors having high rotational inertia. Because here the stored energy has to dissipate mainly through bearing friction and wind friction. The situation can be improved, by forcing the motor to operate as a generator during braking. The idea can be understood remembering that in motor mode electromagnetic torque acts along the direction of rotation while in generator the electromagnetic torque acts in

the opposite direction of rotation. Thus by forcing the machine to operate as generator during the braking period, a torque opposite to the direction of rotation will be imposed on the shaft, thereby helping the machine to come to stop quickly. During braking action, the initial K.E stored in the rotor is either dissipated in an external resistance or fed back to the supply or both.

Rheostatic braking

- Consider a d.c shunt motor operating from a d.c supply with the switch S connected to position 1 as shown in figure 39.23. S is a *single pole double throw switch* and can be connected either to position 1 or to position 2. One end of an external resistance R_b is connected to position 2 of the switch S as shown.

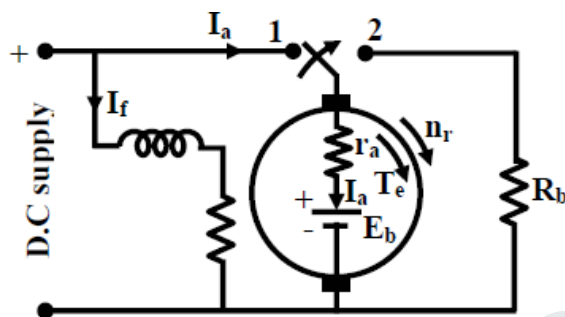

Figure 39.23: Machine operates as motor

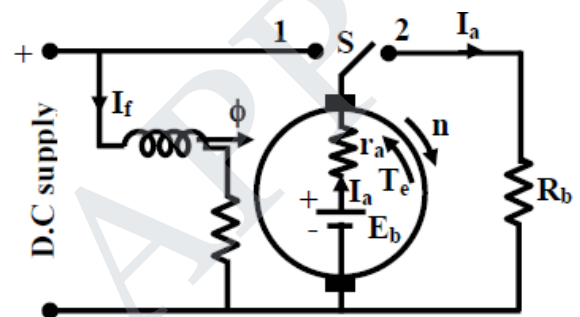

Figure 39.24: Machine operates as generator during braking

- Let with S in position 1, motor runs at n rpm, drawing an armature current I_a and the back emf is $E_b = k\phi n$. Note the polarity of E_b which, as usual for motor mode in opposition with the supply voltage. Also note T_e and n have same clock wise direction.
- Now if S is suddenly thrown to position 2 at $t = 0$, the armature gets disconnected from the supply and terminated by R_b with field coil remains energized from the supply. Since speed of the rotor can not change instantaneously, the back emf value E_b is still maintained with same polarity prevailing at $t = 0$. Thus at $t = 0+$, armature current will be $I_a = E_b / (r_a + R_b)$ and with reversed direction compared to direction prevailing during motor mode at $t = 0$.
- Obviously for $t > 0$, the machine is operating as generator dissipating power to R_b and now the electromagnetic torque T_e must act in the opposite direction to that of n since I_a has changed direction but ϕ has not (recall $T_e \propto \phi I_a$). As time passes after switching, n decreases reducing K.E and as a consequence both E_b and I_a decrease. In other words value of braking torque will be highest at $t = 0+$, and it decreases progressively and becoming zero when the machine finally come to a stop.

Plugging or dynamic braking

- This method of braking can be understood by referring to figures 39.25 and 39.26. Here S is a double pole double throw switch. For usual motoring mode, S is connected to positions 1 and 1'. Across terminals 2 and 2', a series combination of an external resistance R_b and supply voltage with polarity as indicated is connected. However, during motor mode this part of the circuit remains inactive. To initiate braking, the switch is thrown to position 2 and 2' at

$t = 0$, thereby disconnecting the armature from the left hand supply. Here at $t = 0+$, the armature current will be $I_a = (E_b + V)/(r_a + R_b)$ as E_b and the right hand supply voltage have additive polarities by virtue

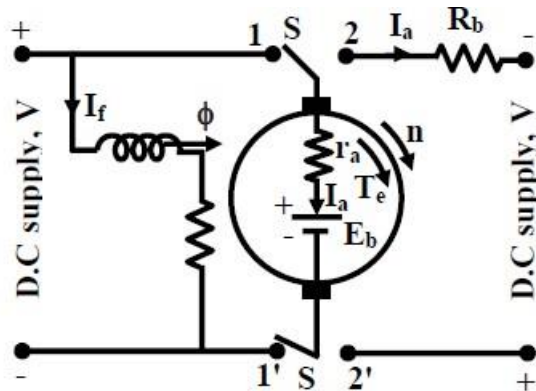

Figure 39.25: Machine operates as motor

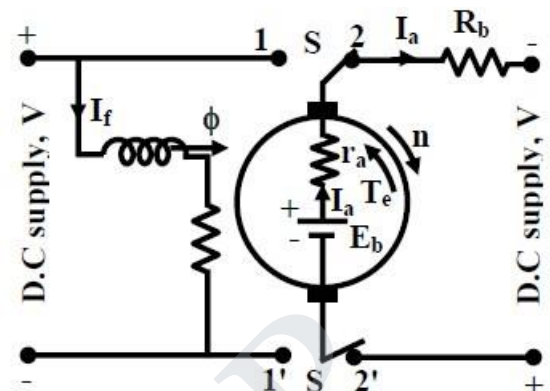

Figure 39.26: Machine operates as generator during braking (plugging).

of the connection. Here also I_a reverses direction producing T_e in opposite direction to n . I_a decreases as E_b decreases with time as speed decreases. However, I_a can not become zero at any time due to presence of supply V . So unlike rheostatic braking, substantial magnitude of braking torque prevails. Hence stopping of the motor is expected to be much faster than rheostatic braking. But what happens, if S continuous to be in position 1' and 2' even after zero speed has been attained? The answer is rather simple, the machine will start picking up speed in the reverse direction operating as a motor. So care should be taken to disconnect the right hand supply, the moment armature speed becomes zero.

Regenerative braking

- A machine operating as motor may go into regenerative braking mode if its speed becomes sufficiently high so as to make back emf greater than the supply voltage i.e., $E_b > V$. Obviously under this condition the direction of I_a will reverse imposing torque which is opposite to the direction of rotation. The situation is explained in figures 39.27 and 39.28. The normal motor operation is shown in figure 39.27 where armature motoring current I_a is drawn from the supply and as usual $E_b < V$. Since $E_b = k\phi n_1$. The question is how speed on its own become large enough to make $E_b < V$ causing regenerative braking. Such a situation may occur in practice when the mechanical load itself becomes active. Imagine the d.c motor is coupled to the wheel of locomotive which is moving along a plain track without any gradient as shown in figure 39.27. Machine is running as a motor at a speed of n_1 rpm. However, when the track has a downward gradient, component of gravitational force along the track also

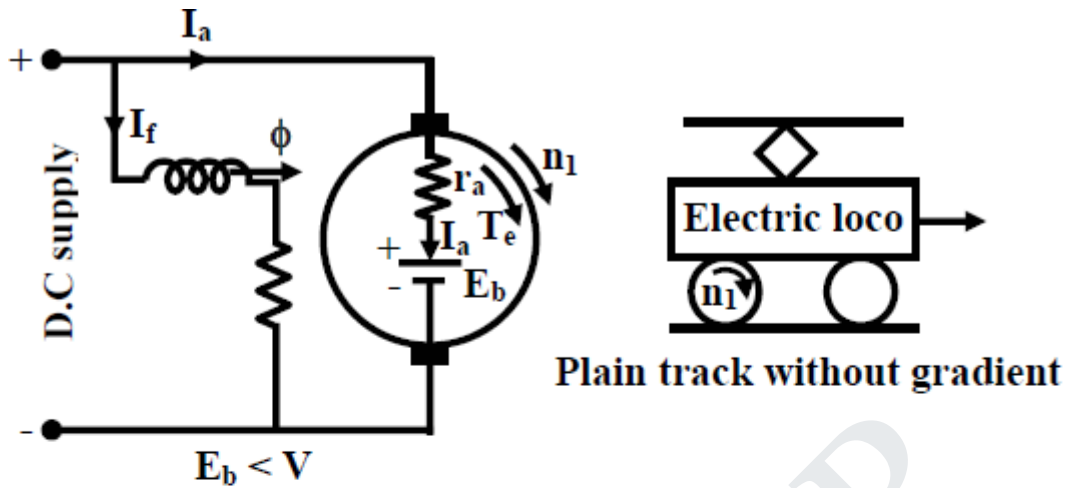
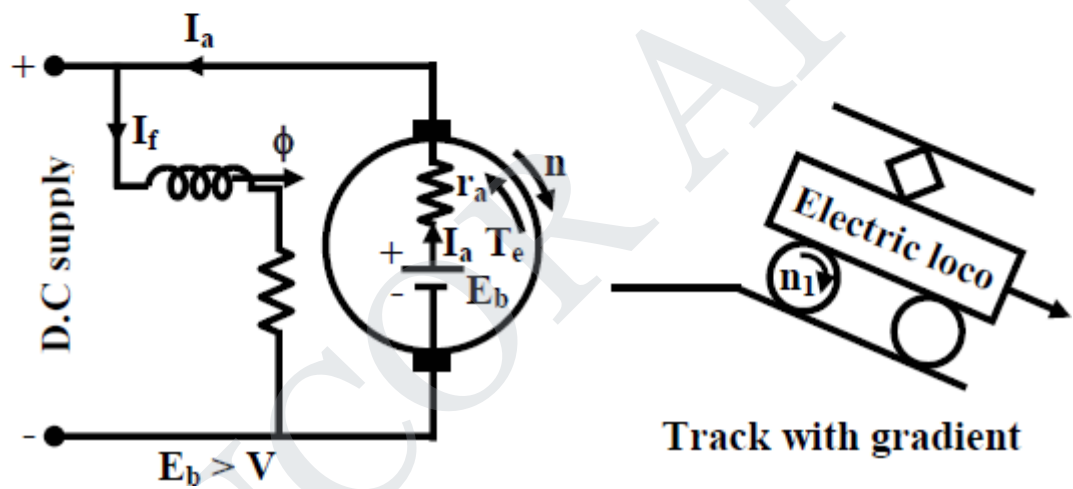

Figure 39.27: Machine operates as motor



appears which will try to accelerate the motor and may increase its speed to n_2 such that $E_b = k\phi n_2 > V$. In such a scenario, direction of I_a reverses, feeding power back to supply. Regenerative braking here will not stop the motor but will help to arrest rise of dangerously high speed.

SOLVED PROBLEMS

1. A 10KW,240V dc shunt motor draws a line current of 5.2 amps while running at no load of 1200rpm from a 240V dc supply. It has an armature resistance of 0.25 ohms and field resistance of 160 ohms . Estimate the efficiency of motor when it delivers rated load.

GIVEN DATA:

Output power = 10KW Supply Voltage V = 240 V
 No-Load current = 5.2A No- Load Speed N = 1200 rpm
 Armature resistance = 0.25 Ω Field resistance = 160 Ω

TO FIND:

Efficiency of the motor at rated load.

SOLUTION:

$$\begin{aligned} \text{No-load input power} &= V \times I \\ &= 240 \times 5.2 \\ &= 1248 \text{ W} \end{aligned}$$

This no-load input power to meet all kinds of no-load losses is armature copper loss and constant loss

$$\text{Shunt field current} = \frac{V}{R_f} = \frac{240}{160}$$

$$= 1.5 \text{ A}$$

$$\text{No-load armature current} = I - I_f = 5.2 - 1.5 = 3.7 \text{ A}$$

$$\begin{aligned} \text{Now no-load armature copper loss} &= I_a^2 R_a \\ &= (3.7)^2 \times 0.25 \\ &= 3.4 \text{ W} \end{aligned}$$

$$\text{Constant loss} = 1248 - 3.4 = 1244.6 \text{ W}$$

$$\text{Rated current (Load) } I_L = \frac{P}{V} = \frac{10000}{240} = 41.667 \text{ A}$$

$$\begin{aligned} \text{Full Load Armature Current } I_a &= I_L + I_f \\ &= 41.667 + 1.5 \\ &= 43.167 \text{ A} \end{aligned}$$

$$\begin{aligned} \text{Full Load Armature Copper loss} &= I_a^2 R_a \\ &= (43.167)^2 \times 0.25 \\ &= 463.3 \text{ W} \end{aligned}$$

$$\begin{aligned} \text{Motor Output} &= P - \text{Total Loss} \\ &= 10000 - (1244.6 + 463.3) \\ &= 8292.1 \text{ W} \end{aligned}$$

$$\begin{aligned} \% \text{ Efficiency} &= \frac{\text{Motor Output}}{P} \times 100 \\ &= \frac{8292.1}{10000} \times 100 \\ &= 82.92\% \end{aligned}$$

2. In a brake test the efficiency load on the branch pulley was 40Kg, the effective diameter of the pulley 73.5 cm and speed 15 rps. The motor takes 60A at 230V. Calculate the output power and efficiency at this load.

3. A 480 V, 20kW, shunt motor of rows 2.5A, when running at with light load .Taking the armature resistance to be 0.6Ω , field resistance to be 800Ω and brush drops at 2V and find full load efficiency.

Ans : $\eta = 94.83\%$

STUCOR APP

GLOSSARY

1. **Magnetic Circuit:** The circuit which produces the magnetic field is known as magnetic circuit.
2. **Stacking Factor:** It is the ratio between the net cross sectional areas of the core to the cross section occupied by the magnetic material.
3. **MMF:**MMF is the work done in moving a unit magnetic pole once around the magnetic circuit.
4. **Magnetic field intensity:** It is the MMF per unit length.
5. **Self Inductance:** The e.m.f induced in a coil due to change of flux in the same coil is known as self inductance
6. **Mutual Inductance:** When two coils are kept closed together, due to the change in flux in one coil , an emf is induced in the another coil
7. **Coupling Coefficient:** The ratio of mutual inductance to the square root of the product of two self inductances.
8. **Multiply excited magnetic field system:** If the electromechanical devices have more than one set of exciting system it is called multiply excited magnetic field system.
9. **Electromechanical energy conversion:** It occurs through the medium of the magnetic stored energy
10. **Critical field resistance:** the resistance of the field circuit which will cause the shunt generator just to build up its emf at a specified field.
11. **Geometric neutral axis (GNA):** GNA is the axis which is situated geometrically or physically in the mid way between adjacent main poles.
12. **Magnetic neutral axis (MNA):**MNA is the axis which passes through the zero crossing of the resultant magnetic field waveform in the air gap.
13. **Conservative system:**It is defined as the combination of the ideal coil magnetic circuit and energy is interchanged between themselves.
14. **Chorded coils:** The coil span is less than full pitched winding by an angle 180 degree.
15. **Slot angle:**It is defined as the ratio of the 180degree to the pole pitch.
16. **Slot pitch:** It is the distance between the two coil sides of the same commutator segments
17. **Pole pitch:** It is the ratio of the total no. of armature coils to the total no of poles.

18. **Distributed windings:** Windings which are spread over a number of slots around the air gap periphery.
19. **Back pitch:** It is defined as the distance between two sides of the same coil is expressed in term so coils sides and denoted by Y_b .
20. **DC Generator:** DC Generator converts mechanical energy into electrical energy.
21. **Commutator:** The Commutator converts the alternating emf into unidirectional or direct emf.
22. **DC Motor:** D.C motor converts electrical energy into mechanical energy.
23. **Torque:** Torque is nothing but turning or twisting force about the axis.
24. **Yoke:** Protecting cover for the whole machine
25. **Interpoles:** To improve Commutation
26. **Brushes:** Collect current from the Commutator
27. **Self Excited:** Field winding supplied from the armature itself.
28. **Separately Excited:** Field winding supplied from the separate supply
29. **EMF:** Electro Motive force
30. **Back emf:** In dc motor as the armature rotates inside magnetic flux an emf is induced in the armature conductor. This emf acts opposite to applied voltage known as back emf.

TWO MARKS QUESTION WITH ANSWER**CHAPTER I
MAGNETIC CIRCUITS AND MAGNETIC MATERIAL**

1. Mention the types of electrical machines.

There are three basic rotating machines types, namely

- a. The dc machines
- b. the poly phase synchronous machine (ac), and
- c. Poly and single phase induction machine (ac) and a stationary machine, namely Transformer

2. State Ohm's law for magnetic circuit.

It states that the magneto motive force across the magnetic element is equal to the product of the magnetic flux through the magnetic element and the reluctance of the magnetic material. It is given by

$$\text{MMF} = \text{Flux} \times \text{Reluctance}$$

3. Define leakage flux

The flux setup in the air paths around the magnetic material is known as leakage flux.

4. Define magnetic reluctance

The opposition offered by the magnetic circuit for the magnetic flux path is known as magnetic reluctance. It is analogous to electric resistance.

5. Draw the typical normal magnetization curve of ferromagnetic material.

6. What is fringing?

In the air gap the magnetic flux fringes out into neighboring air paths due to the reluctance of air gap which causes a non uniform flux density in the air gap of a machine. This effect is called fringing effect.

7. State stacking factor.

The stacking factor is defined as the ratio of the net cross sectional area of a magnetic core to the gross cross sectional area of the magnetic core. Due to lamination net cross sectional area will be always less than gross cross sectional area. Therefore the value of stacking factor is always less than unity.

8. Mention some magnetic materials

Alnicos, chromium steels, copper-nickel alloy, nickel, cobalt, tungsten and aluminium.

9. What is magnetostriction?

When ferromagnetic materials are subjected to magnetizing mmf, these may undergo small changes in dimension; this phenomenon is known as magnetostriction.

10. Define statically induced emf.

The coil remains stationary with respect to flux, but the flux through it changes with time. The emf induced is known as statically induced emf.

11. Define dynamically induced emf.

Flux density distribution remains constant and stationary but the coil move relative to it. The emf induced is known as dynamically induced emf.

12. State Fleming's right hand rule.

Extend the thumb, fore and middle finger of the right hand so that they are mutually perpendicular to each other. If the thumb represents the direction of movement of conductor and the fore finger the direction of magnetic flux, then the middle finger represents the direction of emf

13. State Fleming's Left hand rule.

Extend the thumb, fore and middle finger of the right hand so that they are mutually perpendicular to each other. If the forefinger represents the direction of flux and the middle finger the direction of current, then the middle finger represents the direction of movement of conductor.

14. What are the losses called as core loss?

Hysteresis loss and eddy current loss.

15. Define coercivity.

It is the measure of mmf which, when applied to the magnetic circuit would reduce its flux density to zero, i.e., it demagnetizes the magnetic circuit.

UNIT II TRANSFORMERS

1. Mention the difference between core and shell type transformers.

In core type, the windings surround the core considerably and in shell type the core surround the winding.

2. What is the purpose of laminating the core in a transformers ? (April -98)

To reduce eddy current loss.

3. Give the emf equation of a transformer and define each term (April -99)

Emf induced in primary coil $E_1 = 4.44 f \Phi_m N_1$ volt

Emf induced in secondary coil $E_2 = 4.44 f \Phi_m N_2$ volt

Where f is the frequency of AC input

Φ_m is the maximum value of flux in the core

N_1, N_2 are the number of primary and secondary turns.

4. Does the transformer draw any current when secondary is open ? Why ?

Yes, it (primary) will draw the current from the main supply in order to magnetise the core and to supply iron and copper losses on no load. There will not be any current in the secondary since secondary is open.

5. Define voltage regulation of a transformer (April -98)

When a transformer is loaded with a constant primary voltage, the secondary voltage decreases for lagging power factor load, and increases for leading pf load because of its internal resistance and leakage reactance. The change in secondary terminal voltage from no load to full load expressed as a percentage of no load or full load voltage is termed as regulation.

% regulation down = $(0V_2 - V_2) \times 100 / 0V_2$

% regulation up = $(0V_2 - V_2) \times 100 / V_2$

6. Full load copper loss in a transformer is 1600 watts. What will be the loss at half load ?

If x is the ratio of actual load to full load then copper loss = x^2 (full load copper loss). Here $W_c = (0.5)^2 \times 1600 = 400$ watts

7. Define all day efficiency of a transformer .

It is the computed on the basis of energy consumed during a certain period , usually a day of 24 hrs.

$$\eta_{\text{all day}} = \frac{\text{output in kWh}}{\text{input in kWh for 24 hrs.}}$$

8. Why transformers are rated in kVA ? (May 03)

Copper loss of a transformer depends on current and iron loss on voltage . Hence total losses depend on Volt- Ampere and not on the power factor. That is why the rating of transformers are in kVA and not in kW.

9. What are the typical uses of auto transformer ?

- (i) To give small boost to a distribution cable to correct for the voltage drop.
- (ii) As induction motor starters.
- (iii) As furnace transformers
- (iv) As interconnecting transformers
- (v) In control equipment for single phase and 3 phase electric locomotives.

10. What are the applications of step-up and step-down transformers?

Step-up transformers are used in generating stations. Normally the generated voltage will be either 11 kV or 22 kV. This voltage is stepped up to 110 kV or 220 kV or 400 kV and transmitted through transmission lines. (In short it may be called as sending end). Step-down transformers are used in receiving stations. The voltage are again stepped down to 11 kV or 22 kV and transmitted through feeders. (In short it may be called as receiving end). Further these 11 kV or 22kV are stepped down to 3 phase 400 V by means of a distribution transformer and made available at consumer premises. The transformers used at generating stations and receiving stations are called power transformers.

11. How transformers are classified according to their construction?

Or

Mention the difference between “CORE” and “SHELL” type transformers.

Or

What are the two types of cores used ? Compare them.

Transformers are classified according to their construction as,

- (i) Core type (ii) Shell type (iii) Spirakore type.

Spirakore type is a latest transformer and is used in big transformers. In “core” type, the windings(primary and secondary) surround the core and in “shell” type, the core surround the windings.

12. Explain on the material used for core construction. (Oct 02)

The core is constructed of transformer sheet steel laminations assembled to provide a continuous magnetic path with a minimum of air gap included. The steel used is of high silicon content sometimes heat-treated to produce a high permeability and a low hysteresis loss at the usual operating flux densities. The eddy current loss is minimized by laminating the core, the laminations being insulated from each other by light coat of core-plate varnish or by an oxide layer on the surface .the thickness of laminations varies from 0.35 mm for a frequency of 59 Hz and 0.5 mm for a frequency of 25 Hz.

13. When will a Buchholz relay operate in a transformer?

Buchholz relay is a protective device in a transformer. If the temperature of the coil exceeds its limit, Buchholz relay operates and gives an alarm.

14. How does change in frequency affect the operation of a given transformer?
With a change in frequency, iron loss, copper loss, regulation, efficiency and heating varies and thereby the Operation of the transformer is affected

15. What is the angle by which no-load current will lag the ideal applied voltage?

In an ideal transformer, there are no copper loss and no core loss,(i.e. loss free core).The no load current is only magnetizing current. Therefore the no-load current lags behind by an angle of 90° . However the windings possess resistance and leakage reactance and therefore the no-load current lags the applied voltage slightly less than 90° .

16. List the advantages of stepped core arrangement in a transformer.

- (i) To reduce the space effectively.
- (ii) To obtain reduced length of mean turn of the windings.
- (iii) To reduce I^2R loss.

17. Why are breathers used in transformers?

Breathers are used to entrap the atmospheric moisture and thereby not allowing it to pass on to the transformer oil. Also to permit the oil inside the tank to expand and contract as its temperature increases and decreases. Also to avoid slogging of oil i.e. decomposition of oil. Addition of 8 parts of water in 1000000 reduces the insulations quantity of oil. Normally silica gel is filled in the breather having pink colour. This colour will be changed to white due to continuous use, which is an indication of bad silica gel, it is normally heated and reused.

18. What is the function of transformer oil in a transformer?

Nowadays instead of natural mineral oil, synthetic oils known as ASKRELS (trade name) are used. They are noninflammable; under an electric arc do not decompose to produce inflammable gases. PYROCOLOR oil possesses high dielectric strength. Hence it can be said that transformer oil provides, (i) good insulation and (ii) cooling.

19. A 1100/400 V, 50 Hz single phase transformer has 100 turns on the secondary winding. Calculate the number of turns on its primary.

We know that $V_1 / V_2 = k = N_2 / N_1$

Substituting in above equation $400/1100 = 100/N_1$

$$N_1 = 100/400 \times 1100 \\ = 275 \text{ turns.}$$

20. What are the functions of no-load current in a transformer?

No-load current produces flux and supplies iron loss and copper loss on no-load.

21. How will you transfer the quantities from one circuit to another circuit in a transformer?

1.Secondary to primary 2.Primary to secondary

Symbol Value Symbol Value

V_2 V_2/k V_L kV_1

I_2 kI_2 I_L I_1/k

R_2 R_2/k^2 R_L k^2R_1

X_2 X_2/k^2 X_L' k^2X_1

Z_L Z_L/k^2

22. Can the voltage regulation of a transformer go to negative? If so under what condition?

Yes. If the load has leading power factor.

23. Distinguish between power transformer and distribution transformer.

Power transformers have very high power ratings in the order of MVA. They are used in generating and receiving stations. Sophisticated controls are required. Voltage ranges will be very high. Distribution transformers are used in consumer side. Voltage levels will be medium. Power ranging will be small in order of kVA. Complicated controls are not needed.

24. What is the purpose of providing 'taps' in transformer and where these are provided?

In order to attain the required voltage, 'taps' are provided. Normally it will be provided at low voltage sides

25. Give the method of reducing iron loss in a Transformer (Oct-98)

The iron losses are minimized by using high-grade core material like silicon steel having very low hysteresis loop and by manufacturing the core in the form of laminations.

26. State the condition for maximum efficiency (Oct - 97)

Copper losses = Iron losses

UNIT III

ELECTROMECHANICAL ENERGY CONVERSION AND CONCEPT IN ROTATING MACHINES

28. What is an electromechanical system?

The system in which the electromechanical energy conversion takes place via the medium of a magnetic or electric field is called electromechanical system.

29. Describe multiply excited magnetic field system.

The specially designed transducers have the special requirement of producing an electrical signal proportional to forces or velocities of producing force proportional to electrical signal. Such transducers requires two or more excitation called as multiply excited magnetic field system.

30. Define co energy.

Co energy is an energy used for a linear system computation keeping current as constant. It will not be applied to the non linear systems.

31. How energy is stored?

Energy can be stored or retrieved from the magnetic system by means of an exciting coil connected to an electric source.

32. Write the equation for mechanical force.

33. Write the equation that governs doubly excited magnetic field.

34. Define field energy.

The energy drawn by virtue of change in the distance moved by the rotor in electrical machines in field configuration is known as field energy.

35. Draw the graphical relation between field energy and coenergy

36. Define the term pole pitch

The distance between the centres of two adjacent poles is called pole pitch, one pole pitch is equal to 180 electrical degrees. It is also defined as the number of slots per pole.

37. Define pitch factor

It is defined as the ratio of resultant emf when coil is short pitch to the resultant emf when coil is full pitched. It is always less than one. Pitch factor is always termed as coil span (K_c) factor

$k_c = \cos \alpha/2$ where α = angle of short pitch

38. Define the term breadth factor

The breadth factor is also called distribution factor or winding factor. The factor by which there is a reduction in the emf due to distribution of coil is called distribution factor denoted as k_d .

39. Write down the advantages of short pitched coil.

(i) The length required for the end connection of coils is less i.e., inactive length of winding is less. So less copper is required. Hence economical.

(ii) Short pitching eliminated high frequency harmonics which distort the sinusoidal nature of emf. Hence waveform of an induced emf is more sinusoidal due to short pitching.

(iii) As high frequency harmonics get eliminated, eddy current and hysteresis losses which depend on frequency also get minimized. This increases the efficiency.

40. What is distributed winding?

If 'x' conductors per phase are distributed amongst the 3 slots per phase available under pole, the winding is called distributed winding.

41. Explain the following terms with respect to rotating electrical machines.

a) Pole pitch

b) Chording angle.

Pole pitch: The distance between the centres of two adjacent poles is called pole pitch. One pole pitch is equal to 180 electrical degrees. It is also defined as the number of slots per pole.

Chording angle: It is defined as that angle by which the coil pitch departs from 180 electrical degrees.

UNIT IV DC GENERATOR

41. Write the expressions for the synchronous speed.

The speed of rotating magnetic field is called synchronous speed.

43. Write the mmf equation of dc machine.

The fundamental component of mmf wave is given by

Where θ = electrical angle measured from the magnetic axis of the coil which coincides with the positive peak of the fundamental wave.

44. What is meant by electromagnetic torque?

When the stator and rotor windings of the machine both carry currents, they produce their own magnetic fields along their respective axes which sinusoidally distributed along the air-gaps. Torque results from the tendency of these two fields to align themselves.

45. State the torque equation for round rotor machine.

Where $P =$ No. pole

$D =$ Average diameter of air gap

$l =$ Axial length of air gap

$\mu_0 =$ Permeability of free space $= 4\pi \times 10^{-7}$ H/m

$g =$ air gap length

$F_1 =$ Peak value of sinusoidal mmf stator wave

$F_2 =$ peak value of sinusoidal mmf rotor wave

$A =$ Angle between F_1 and F_2 called torque angle

46. Define rotating magnetic field.

When a balanced three phase winding with phase distributed in space so that the relative space angle is 120° is fed with balanced 3 phase current, resultant mmf rotates in air gap at speed.

47. What is prime mover?

The basic source of mechanical power, which drives the armature of the generator, is called prime mover.

48. Give the materials used in machine manufacturing

Three materials are used in machine manufacturing.

(i) steel – to conduct magnetic flux

(ii) copper – to conduct electric current

(iii) Insulation

49. How will you change the direction of rotation of a d.c motor?

Either the direction of the main field or the direction of current through the armature conductors is to be reversed.

50. What is back emf in d.c motors ?

As the motor armature rotates, the system of conductor come across alternate North and South pole magnetic fields causing an emf induced in the conductors. The direction of the emf induced in the conductors. The direction of the emf induced is in the direction opposite to the current. As this emf always opposes the flow of current in motor operation it is called back emf.

51. Under what condition the mechanical power developed in a dc motor will be maximum?

Condition for mechanical power developed to be maximum is

$$E_b = U_a / 2$$

$$\text{or } I_a = U_a / 2R_a$$

52. What is the function of a no-voltage release coil provided in a dc motor starter?

As long as the supply voltage is on healthy condition the current through the NVR coil produce enough magnetic force of attraction and retain the starter handle in the ON position against spring force. When the supply voltage fails or becomes lower than a prescribed value the electromagnet may not have enough force and the handle will come back to OFF position due to spring force automatically. Thus a no-voltage or under voltage protections given to the motor.

53. Name the two types of automatic starters used for dc motors.

- Back emf type starter

- Time delay type starter
54. Enumerate the factors on which the speed of a dc motor depends.

$$N = 1/C_E(U_a - I_a R_m) / \phi$$
 The speed of dc motor depends on three factors.
 - Flux in the air gap
 - Resistance of the armature circuit
 - Voltage applied to the armature
55. List the different methods of speed control employed for dc series motor(APR'04,AU)
 - Field diverter method
 - Regrouping of field coils
 - Tapped field control
 - Armature resistance control
 - Armature voltage control for single motor
 - Series parallel control for multiple identical motors
57. Name the different methods of electrical braking of dc motors.
 - (i) Dynamic braking
 - (ii) Regenerating braking
 - (iii) Counter current braking or plugging
58. Under what circumstances does a dc shunt generator fail to build up?
 - Absence of residual flux.
 - Initial flux set up by the field winding may be in opposite direction to residual flux
 - Shunt field circuit resistance may be higher than its critical field Resistance
 - Load circuit resistance may be less than its critical load resistance.

UNIT V DC MOTOR

59. To what polarity the interpoles excited in dc motors?
 For motor operation the polarity of the interpoles must be that of the previous main pole along the direction of rotation.
60. Name any four applications of DC series motor.
 - Electric traction
 - Mixies
 - Hoists
 - Drilling machines
61. Why DC motors are not operated to develop maximum power in practice?
 The current obtained will be much higher than the rated current. The efficiency of operation will be below 50%.
62. Name the starters used for series motors.
 - Face plate type.
 - Drum type controller.
63. Name Different types of starters.

1. Three point starter
 2. Four point starter.
64. Name the Protective devices in a starter.
- 1, No volt release
 2. Overload Release.
65. Draw torque characteristics of shunt motor.(NOV'03,AU)
66. What are the modification in ward Leonard linger system?
1. Smaller motor and generator set
 2. Addition of flywheel whose function is to reduce fluctuations in the power demand from the supply circuit.
67. What type of DC motors are suitable for various torque operations?
1. DC series motor
 2. DC cumulatively compound motor
24. Define speed regulation.
- $$\% \text{ Speed regulation} = \frac{\text{NL speed} - \text{FL speed}}{\text{FL speed}} \times 100$$
68. What are the performance curves?
- Output Vs torque
 - Output Vs current
 - Output Vs speed
 - Output Vs efficiency
69. To what polarity are the interpoles excited in dc generators?
- The polarity of the interpoles must be that of the next main pole along the direction of rotation in the case of generator.
70. Why are carbon brushes preferred for dc machines?
- The high contact resistance carbon brushes help the current in the coil undergoing commutation to attain its full value in the reverse direction at the end of commutation. The carbon brushes also lubricate and give less wear and tear on commutator surface.
71. What are the various types of commutation?
- Linear commutation
 - Sinusoidal commutation
72. Name the two methods of improving commutation.
- (i) Emf commutation.
 - (ii)Resistance commutation
73. What is reactance emf in dc machine?
- The self-induced emf in the coil undergoing commutation which opposes the reversal of current is known as reactance emf.
74. Define the term commutation in dc machines.
- The changes that take place in winding elements during the period of short circuit by a brush is called commutation.
75. How and why the compensating winding in dc machine excited?
- As the compensation required is proportional to the armature current the compensating winding is excited by the armature current.

B.E./B.Tech. DEGREE EXAMINATION, APRIL/MAY 2010.

Fourth Semester

Electrical and Electronics Engineering

EE2251 — ELECTRICAL MACHINES — I

(Regulation 2008)

Time: Three hours Maximum: 100 Marks

Answer ALL Questions

PART A — (10 × 2 = 20 Marks)

1. Define Torque.
2. How is emf induced dynamically?
3. Give the principle of transformers.
4. What are the conditions for parallel operation of transformers?
5. In a linear system prove that field energy and co-energy are equal.
6. Write an expression for the stored energy in the magnetic field.
7. What are the basic magnetic field effects that result in the production of mechanical forces?
8. What are the assumptions made to determine the distribution of coil mmf?
9. What is armature reaction?
10. What are the methods <http://www.eeecube.blogspot.c>

PART B — (5 × 16 = 80 Marks)

11. (a) Discuss in detail the following:

- (i) B-H relationship
- (ii) Leakage flux
- (iii) Fringing
- (iv) Stacking factor. (4 × 4 = 16)

Or

(b) (i) Derive an expression for energy density in the magnetic field. (6)

(ii) Explain in detail "Eddy – current loss". (5)

(iii) The total core loss of a specimen of silicon steel is found to be 1500 W at 50 Hz. Keeping the flux density constant the loss becomes 3000 W when the frequency is raised to 75 Hz. Calculate separately the hysteresis and eddy current loss at each of these frequencies. (5)

12. (a) (i) Draw the equivalent circuit of single phase transformer and draw the necessary phasor diagram under load (8)

(1) Resistive

(2) Inductive

(3) Capacitive.

(ii) Explain in detail the tests required to obtain the equivalent circuit parameters of transformer. (8)

Or

(b) (i) Explain in detail the various types of three phase transformer connection. (10)

(ii) Prove that amount of copper saved in auto transformer is $(1 - K)$ times that of ordinary transformer. (6)

13. (a) (i) Derive an expression for mechanical force in terms of field energy. (8)

(ii) Discuss the flow of energy in electromechanical devices in detail. (8)

Or

(b) (i) Derive an expression for torque in case of a multiply excited magnetic field system. (8)

(ii) Two coupled coils have self and mutual inductance of

$$L_{11}, L_{22}, M_{12} = M_{21}; \quad L_{11} > 0, L_{22} > 0, M_{12} < 0, M_{21} < 0$$

over a certain range of linear

displacement x . The first coil is excited by a constant current of 20A and the second by a constant current of $-10A$. Find:

- (1) Mechanical work done if x changes from 0.5 to 1 m.
- (2) Energy supplied by each electrical source in part (a).
- (3) Change in field energy. (8)

14. (a) Explain in detail the basic concept of a synchronous generator with a neat diagram and the necessary space wave form. (16)

Or

(b) (i) Discuss the basic concept of emf generation in a DC machine in detail. (8)

(ii) What is MMF space wave of a single coil and in a distributed winding? (8)

15. (a) (i) Explain armature reaction and commutation in detail. (8)

(ii) Draw the

(1) OCC characteristics of DC generator and (4)

(2) External characteristics of DC generator. (4)

Or

(b) (i) Explain in detail the various methods of speed control in DC motor.

(8)

(ii) What are the various starting methods of DC motor? Explain any one method. (8)

Reg. No. :

--	--	--	--	--	--	--	--	--	--

Question Paper Code : 53136

B.E./B.Tech. DEGREE EXAMINATION, NOVEMBER/DECEMBER 2010

Fourth Semester

Electrical and Electronics Engineering

EE 2251 — ELECTRICAL MACHINES – I

(Regulation 2008)

Time : Three hours

Maximum : 100 Marks

Answer ALL questions

PART A — (10 × 2 = 20 Marks)

1. Give the analogy between electric circuit and magnetic circuit.
2. Distinguish between statically and dynamically induced electromotive force.
3. What are the no load losses in a two winding transformer and state the reasons for such losses.
4. Mention the conditions to be satisfied for parallel operation of two winding transformers.
5. Draw the power flow diagram for motor and generator operation.
6. In a magnetic circuit with a small air gap, in which part the maximum energy is stored and why?
7. Explain the concept of electrical degree. How is the electrical angle of the voltage in a rotor conductor related to the mechanical angle of the machine's shaft?
8. Why does curving the pole faces in a D.C. machine contribute to a smoother D.C. output voltage from it?
9. State the conditions under which a D.C. shunt generator fails to excite.
10. What is the precaution to be taken during starting of a D.C. series motor? Why?

PART B — (5 × 16 = 80 Marks)

11. (a) (i) Define inductance of a coil. (4)
- (ii) For the magnetic circuit shown in Fig. 11.a (ii) determine the current required to establish a flux density of 0.5 T in the air gap. (12)

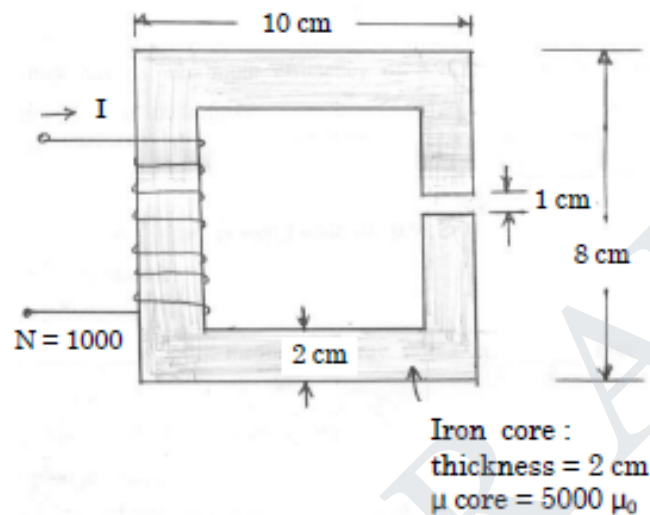

Fig. 11 (a) (ii)

Or

- (b) (i) <http://www.eeecube.blogspot.com> material and the factors on which it depends. (4)
- (ii) Explain the operation of a magnetic circuit when A.C. current is applied to the coil wound on iron core. Draw the B-H curve and obtain an expression for hysteresis loss. (12)
12. (a) (i) Define "Voltage Regulation" of a two winding transformer and explain its significance. (4)
- (ii) A 100 kVA, 6600 V/ 330 V, 50 Hz single phase transformer took 10 A and 436 W at 100 V in a short circuit test, the figures referring to the high voltage side. Calculate the voltage to be applied to the high voltage side on full load at power factor 0.8 lagging when the secondary terminal voltage is 330 V. (12)

Or

- (b) (i) Explain the reasons for 'tap changing' in transformers. State on which winding the taps are provided and why? (4)
- (ii) A transformer has its maximum efficiency of 0.98 at 15 kVA at unity power factor. During the day it is loaded as follows :
- | | | |
|----------|---------|------------------------|
| 12 Hours | 2 kW | at power factor of 0.5 |
| 6 Hours | 12 kW | at power factor of 0.8 |
| 4 Hours | 18 kW | at power factor of 0.9 |
| 2 Hours | No load | |
- Find the 'All Day Efficiency'? (12)

13. (a) (i) Derive an expression for the magnetic energy stored in a singly excited electromagnetic relay. (8)
- (ii) The relay shown in Fig. Q.13.a (ii) is made from infinitely permeable magnetic material with a movable plunger also of infinitely permeable material. The height of the plunger is much greater than the air gap length ($h \gg g$). Calculate the magnetic energy stored as a function of plunger position ($0 < x < d$) for $N=1000$ turns, $g = 2.0$ mm, $d=0.5$ m, $l = 0.1$ m and $I = 10$ A. (8)

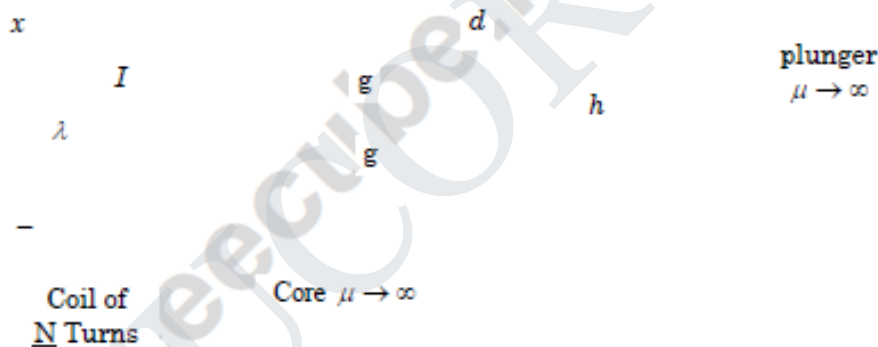

Fig. Q. 13. (a) (ii)

Or

- (b) Two windings one mounted on the stator and the other mounted on a rotor have self and mutual inductances of $L_{11} = 4.5$ H, $L_{22} = 2.5$ H and $L_{12} = 2.8 \cos \theta$ H, where θ is the angle between the axes of the windings. The resistances of the windings may be neglected. Winding 2 is short circuited and the current in Winding 1 as a function of time is $i_1 = 10 \sin \omega t$ A. Derive an expression for the numerical value of the instantaneous torque on the rotor in N-m in terms of the angle θ . (16)

- (ii) Prove that a three phase set of currents, each of equal magnitude and differing in space by 120° applied to a three phase winding spaced 120 electrical degrees apart around the surface of the machine will produce a rotating magnetic field of constant magnitude. (10)

Or

- (b) (i) A D.C. machine has 'P' number of poles with curved pole faces having 'Z' number of conductors around the rotor armature of radius 'r' and the flux per pole is given as, ϕ . The rotor rotates at a speed of 'n' rpm. Obtain the induced e.m.f. of the D.C. machine assuming a number of parallel paths. (8)
- (ii) A 12 pole D.C. generator has a simplex wave wound armature containing 144 coils of 10 turns each. The resistance of each turn is 0.011Ω . Its flux per pole is 0.05 Wb and it is running at a speed of 200 rpm. Obtain the induced armature voltage and the effective armature resistance. (8)
15. (a) (i) Draw the load characteristics of D.C. shunt and compound (cumulative and differential) generators and explain. (6)
- (ii) In a 110 V, compound generator the resistances of the armature shunt and series field windings are 0.06Ω , 25Ω and 0.04Ω respectively. The machine is rated at 55 W, 110 V. Find the armature current when the machine is connected long shunt and short shunt. (10)

Or

- (b) (i) Give the reasons for using 'starters' to start D.C. motors. (3)
- (ii) Draw the circuit of any one type of starter and explain its operation. (5)
- (iii) A series motor of resistance 1Ω between terminals runs at 800 rpm at 200 V with a current of 15 A. Find the speed at which it will run when connected in series with a 5Ω resistance and taking the same current at the same supply voltage. (8)

B.E./B.Tech. DEGREE EXAMINATION, NOVEMBER/DECEMBER 2011.

Fourth Semester

Electrical and Electronics Engineering

EE 2251 — ELECTRICAL MACHINES — I

(Regulation 2008)

Time : Three hours

Maximum : 100 marks

Answer ALL questions.

PART A — (10 × 2 = 20 marks)

1. Define statically and dynamically induced EMF.
2. What is Hysteresis loss and how can this loss be minimized?
3. Why is transformer rated in KVA?
4. Compare two winding transformer and auto transformer.
5. What are the advantages of analyzing energy conversion devices by field energy concept?
6. Draw the general block diagram of electromechanical energy conversion device.
7. What is back EMF in a D.C. motor?
8. Define winding factor.
9. What is armature reaction in DC machines?
10. Explain why Swinburne's test cannot be performed on DC series motor.

PART B — (5 × 16 = 80 marks)

11. (a) Compare electric and magnetic circuit by their similarities and dissimilarities. (16)
- Or
- (b) A ring composed of three sections. The cross section area is 0.001 m^2 for each section. The mean arc length are $l_a = 0.3 \text{ m}$, $l_b = 0.2 \text{ m}$, $l_c = 0.1 \text{ m}$. an air gap length of 0.1 mm is cut in the ring. μ_r for sections a, b and c are 5000, 1000 and 10000 respectively. Flux in the air gap is $7.5 \times 10^{-4} \text{ Wb}$. Find (i) mmf (ii) exciting current if the coil has 100 turns (iii) reluctance of the sections.
12. (a) (i) Explain clearly the causes of voltage drop in a power transformer on load and develop the equivalent circuit for a single phase transformer. (10)
- (ii) Derive an expression for saving of copper when an auto transformer is used. (6)
- Or
- (b) A 3-phase step down transformer is connected to 6.6 KV mains and takes 10 Amps. Calculate the secondary line voltage and line current for the (i) Δ/Δ (ii) Y/Y (iii) Δ/Y and (iv) Y/Δ connections. The ratio of turns per phase is 12 and neglect no load losses. (16)
13. (a) Obtain an expression for the mechanical force of field origin in a typical attracted armature relay. (16)
- Or
- (b) Find an expression for the magnetic force developed in a doubly excited magnetic systems. (16)
14. (a) Derive an expression for emf generated in
- (i) Synchronous machine (8)
- (ii) D.C machine. (8)
- Or
- (b) A 3Φ , 50 Hz, star connected alternator with two layer winding is running at 600 rpm. It has 12 turns/ coil, 4 slots/pole/phase and a coil pitch of 10 slots. If the flux per pole is 0.035 Wb sinusoidally distributed, Find the phase and line emf induced. Assume that the total turns/phase are series connected.
15. (a) Explain the different methods of excitation and characteristics of a DC motors with suitable diagrams. (16)
- Or
- (b) Explain the Ward-Leonard system of controlling the speed of a DC shunt motor with help of neat diagram. (16)

B.E./B.Tech. DEGREE EXAMINATION, APRIL/MAY 2008.

Third Semester

Electronics and Communication Engineering

EE 1211 — ELECTRICAL MACHINES

(Common to Electronics and Instrumentation Engineering and
Instrumentation and Control Engineering)

(Regulation 2004)

Time : Three hours

Maximum : 100 marks

Answer ALL questions.

PART A — (10 × 2 = 20 marks)

1. What is a self excited d.c. machine?
2. State the advantages of Swinburne's test.
3. What is a step up transformer?
4. Draw the no load phasor diagram of single phase transformer.
5. Define slip of an induction motor.
6. List out four applications of single phase induction motor.
7. State any two applications of stepper motor.
8. Define voltage regulation of alternator.
9. What is the need of a sub-station in the power system?
10. What are the different types of cables generally used for 3-phase service?

PART B — (5 × 16 = 80 marks)

11. (a) (i) Discuss how a d.c. generator builds up e.m.f. (8)
- (ii) A 4 pole generator with wave wound armature has 51 slots each having 24 conductors. The flux per pole is 0.01 weber. At what speed must the armature rotate to give an induced e.m.f. of 250 V. What will be the voltage developed, if the winding is lap connected and the armature rotates at the same speed? (8)

Or

- (b) (i) Draw and explain the characteristics of D.C. shunt and series motors. (8)
- (ii) A 400 V d.c. shunt motor takes 5 A at no load. Its armature resistance (including brushes) is 0.5Ω and shunt field resistance is 200Ω . Estimate the efficiency when the motor takes 50 A on full load. (8)
12. (a) Explain how the efficiency of a transformer may be found from the open circuit and short circuit tests.

Or

- (b) (i) Describe the constructional features of any one type of single phase transformer. (8)
- (ii) A 600 kVA single phase transformer has an efficiency of 94 % both at full load and half load at unity power factor. Determine the efficiency at 75% of full load at 0.9 power factor. (8)
13. (a) (i) Explain the principle of operation of 3 phase induction motor. (8)
- (ii) Explain any one method of speed control technique adopted for speed control of a 3 phase induction motor. (8)

Or

- (b) Write a brief note on :
- (i) Shaded pole induction motor
- (ii) Capacitor starts and Run induction motor. (8 + 8)

14. (a) Describe the method of determining the regulation of an alternator by synchronous impedance method.

Or

- (b) Explain using a diagram the construction and working of reluctance motor.
15. (a) Explain the working of Nuclear power generation plant with schematic arrangement.

Or

- (b) Explain in detail about different types of insulators.

STUCOR APP

B.E./B.Tech. DEGREE EXAMINATION, MAY/JUNE 2007.

Third Semester

(Regulation 2004)

Electrical and Electronics Engineering

EE 1202 — ELECTRICAL MACHINES – I

(Common to B.E. (Part Time) Second Semester Regulation – 2005)

Time : Three hours

Maximum : 100 marks

Answer ALL questions.

PART A — (10 × 2 = 20 marks)

1. Why do all practical energy conversion devices make use of the magnetic field as a coupling medium rather than an electric field?
2. State the necessary conditions for production of steady torque by the interaction of stator and rotor fields in an electric machine.
3. The series field winding has low resistance while the shunt field winding has high resistance. Why?
4. What are the arrangements to be done for satisfactory parallel operation of DC series generators?
5. Draw the mechanical characteristics of all types of DC motors in the same diagram.
6. How does 4-point starter differ from 3-point starter?
7. Under what value of power factor a Transformer gives zero voltage regulation?
8. Why is the Auto-Transformer not used as Distribution Transformer?
9. At what load does the efficiency is maximum in DC shunt machines?
10. Why is the short-circuit test on a Transformer performed on HV (High voltage) side?

PART B — (5 × 16 = 80 marks)

11. (a) (i) Explain why distributed field winding is employed in cylindrical rotor synchronous machine. (6)
- (ii) With neat sketch, explain the multiple-excited magnetic field systems in electromechanical energy conversion system. Also obtain the expression for field energy in the system. (10)

OR

- (b) (i) Explain clearly how a rotating magnetic field is setup around the 3-phase AC winding having 120° (electrical) phase displacement each when 3-phase balanced supply is given to it. (8)
- (ii) Obtain the torque equation for round rotor machine having p number of poles. State the assumptions made. (8)
12. (a) (i) Briefly explain the load characteristics of different types of compound generators. (8)
- (ii) A 4-pole, lap connected DC machine has 540 armature conductors. If the flux per pole is 0.03 Wb and runs at 1500 rpm, determine the emf generated. If this machine is driven as a shunt generator with the same field flux and speed, calculate the terminal voltage when it supplies a load resistance of $40\ \Omega$. Given armature resistance as $2\ \Omega$ and shunt field circuit resistance as $450\ \Omega$. Also find the load current. (8)

Or

- (b) (i) Two separately excited dc generators are connected in parallel. Discuss in detail how they share a load. (8)
- (ii) The brushes of a 400 kW, 500 V, 6-pole DC generator are given a lead of 12° electrical. Calculate (1) the demagnetising ampere-turns, (2) the cross-magnetizing ampere-turns and (3) series turns required to balance the demagnetising component. The machine has 1000 conductors and the leakage co-efficient is 1.4. (8)
13. (a) (i) Derive from the first principle an expression for the torque developed in a DC motor. (8)
- (ii) A 220 V DC shunt motor takes 5 A on no-load and runs at 750 rpm. The resistances of the armature and shunt field windings are $0.2\ \Omega$ and $110\ \Omega$ respectively. Calculate the speed when motor is loaded and taking a current of 50 A. Assume that armature reaction weakens the field by 3%. (8)

Or

- (b) A 220 V, DC shunt motor with an armature resistance of 0.4Ω and a field resistance of 110Ω drives a load, the torque of which remains constant. The motor draws from the supply, a line current of 32 A when the speed is 450 rpm. If the speed is to be raised to 700 rpm what change must be effected in the value of the shunt field circuit resistance? Assume that the magnetization characteristic of the motor is a straight line. (16)
14. (a) (i) A 100 kVA, 6.6 kV/415 V single-phase Transformer has an effective impedance of $(3+j8) \Omega$ referred to HV side. Estimate the full-load voltage regulation at 0.8 pf lagging and 0.8 pf leading. (10)
- (ii) Explain the need for parallel operation of single-phase Transformers Give the conditions to be satisfied for their successful operation. (6)

Or

- (b) (i) The emf per turn of a single-phase, 6.6 kV, 440 V 50 Hz transformer is approximately 12 V. Calculate number of turns in the HV and LV windings and the net cross-sectional area of the core for a maximum flux density of 1.5 T. (6)
- (ii) Explain the Open Delta connection to carry out 3-phase operation with the help of two transformers. State the disadvantage also. (10)
15. (a) The Hopkinson's test on two identical shunt machines gave the following results. Line voltage 230 V; line current excluding field current is 50 A; motor armature current is 380 A; generator and motor field currents are 5 A and 4.2 A respectively; armature resistance of each machine is 0.025Ω . Calculate the efficiency of each machine at this load condition. (16)

Or

- (b) (i) Show that the maximum efficiency in a transformer occurs when its variable loss is equal to constant loss. (6)
- (ii) Find the all-day efficiency of a 500 kVA distribution Transformer whose iron loss and full-load copper loss are 1.5 kW and 6 kW respectively. In a day, it is loaded as follows. (10)

Duration (H _i)	Output (P _o) in kW	Power factor ($\cos \phi_2$)
6	400	0.8
10	300	0.75
4	100	0.8
4	0	—