

Syllabus

ME8694	HYDRAULICS AND PNEUMATICS	L	T	P	C
		3	0	0	3

OBJECTIVES:

- To provide student with knowledge on the application of fluid power in process, construction and manufacturing Industries.
- To provide students with an understanding of the fluids and components utilized in modern industrial fluid power system.
- To develop a measurable degree of competence in the design, construction and operation of fluid power circuits.

UNIT I FLUID POWER PRINCIPLES AND HYDRAULIC PUMPS 9

Introduction to Fluid power – Advantages and Applications – Fluid power systems – Types of fluids - Properties of fluids and selection – Basics of Hydraulics – Pascal's Law – Principles of flow - Friction loss – Work, Power and Torque Problems, Sources of Hydraulic power : Pumping Theory – Pump Classification – Construction, Working, Design, Advantages, Disadvantages, Performance, Selection criteria of Linear and Rotary – Fixed and Variable displacement pumps – Problems.

UNIT II HYDRAULIC ACTUATORS AND CONTROL COMPONENTS 9

Hydraulic Actuators: Cylinders – Types and construction, Application, Hydraulic cushioning – Hydraulic motors - Control Components : Direction Control, Flow control and pressure control valves – Types, Construction and Operation – Servo and Proportional valves – Applications – Accessories : Reservoirs, Pressure Switches – Applications – Fluid Power ANSI Symbols – Problems.

UNIT III HYDRAULIC CIRCUITS AND SYSTEMS 9

Accumulators, Intensifiers, Industrial hydraulic circuits – Regenerative, Pump Unloading, Double-Pump, Pressure Intensifier, Air-over oil, Sequence, Reciprocation, Synchronization, Fail-Safe, Speed Control, Hydrostatic transmission, Electro hydraulic circuits, Mechanical hydraulic servo systems.

UNIT IV PNEUMATIC AND ELECTRO PNEUMATIC SYSTEMS 9

Properties of air – Perfect Gas Laws – Compressor – Filters, Regulator, Lubricator, Muffler, Air control Valves, Quick Exhaust Valves, Pneumatic actuators, Design of Pneumatic circuit – Cascade method – Electro Pneumatic System – Elements – Ladder diagram – Problems, Introduction to fluidics and pneumatic logic circuits.

UNIT V TROUBLE SHOOTING AND APPLICATIONS 9

Installation, Selection, Maintenance, Trouble Shooting and Remedies in Hydraulic and Pneumatic systems, Design of hydraulic circuits for Drilling, Planning, Shaping, Surface grinding, Press and Forklift applications. Design of Pneumatic circuits for Pick and Place applications and tool handling in CNC Machine tools – Low cost Automation – Hydraulic and Pneumatic power packs.

TOTAL:45 PERIODS

OUTCOMES:

Upon the completion of this course the students will be able to	
CO1	Explain the Fluid power and operation of different types of pumps.
CO2	Summarize the features and functions of Hydraulic motors, actuators and Flow control valves
CO3	Explain the different types of Hydraulic circuits and systems
CO4	Explain the working of different pneumatic circuits and systems
CO5	Summarize the various trouble shooting methods and applications of hydraulic and pneumatic systems.

TEXT BOOKS:

1. Anthony Esposito, "Fluid Power with Applications", Pearson Education 2005.
2. Majumdar S.R., "Oil Hydraulics Systems- Principles and Maintenance", Tata McGraw- Hill, 2001.

REFERENCES:

1. Anthony Lal, "Oil hydraulics in the service of industry", Allied publishers, 1982.
2. Dudelyt, A. Pease and John T. Pippenger, "Basic Fluid Power", Prentice Hall, 1987.
3. Majumdar S.R., "Pneumatic systems – Principles and maintenance", Tata McGraw Hill, 1995
4. Michael J, Prinches and Ashby J. G, "Power Hydraulics", Prentice Hall, 1989.
5. Shanmugasundaram.K, "Hydraulic and Pneumatic controls", Chand & Co, 2006.

Graphical Representation

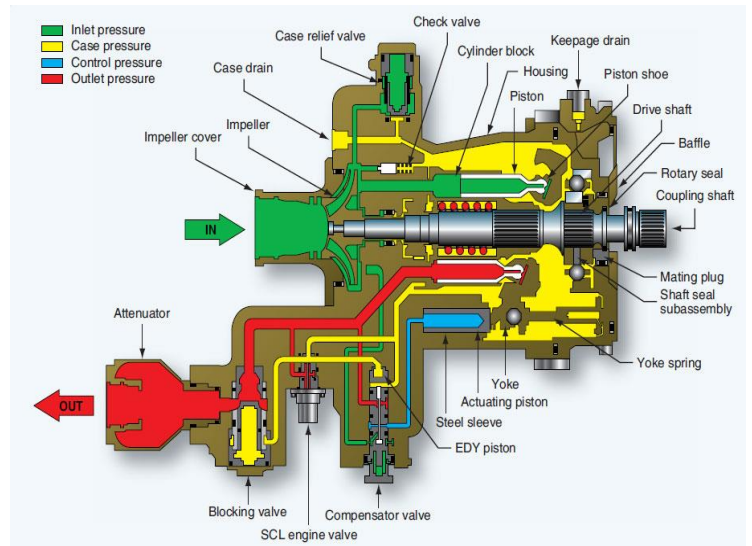
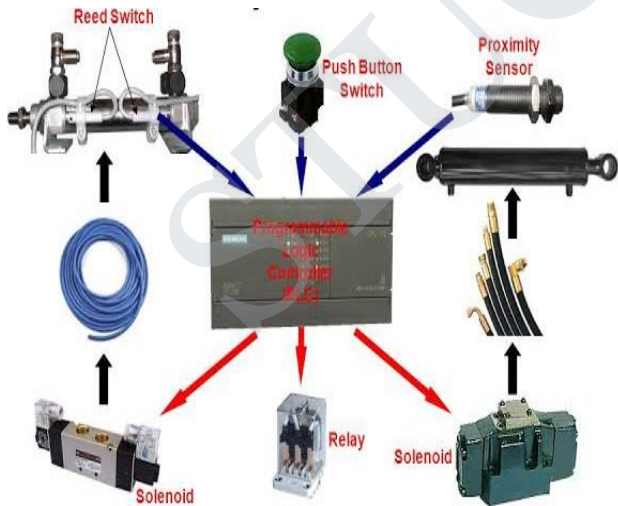
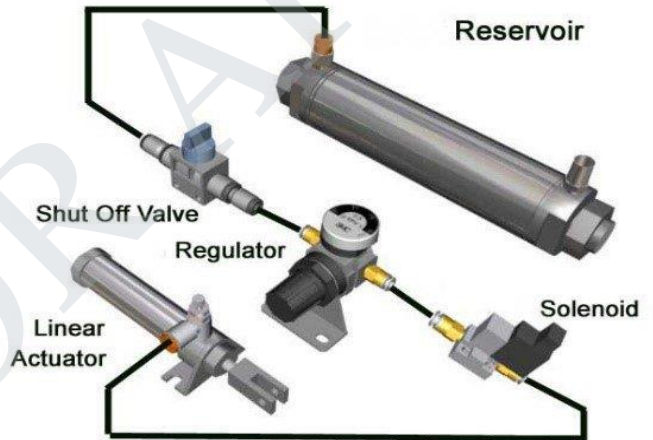
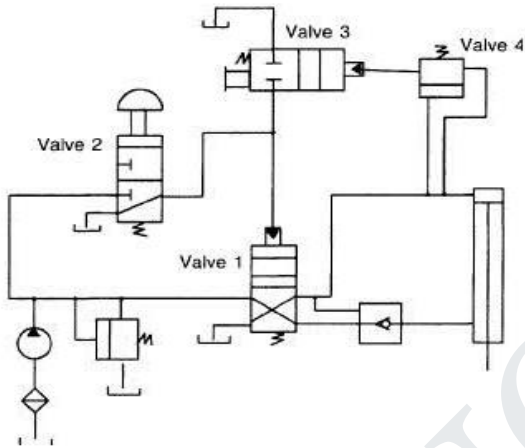
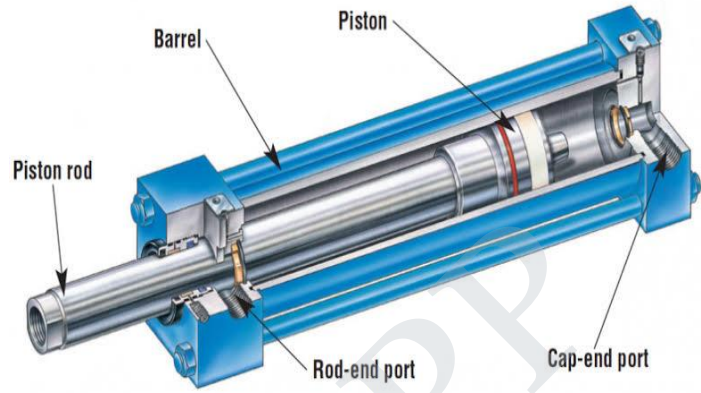

UNIT I**FLUID POWER PRINCIPLES AND HYDRAULIC PUMPS****PART-A**

1. Define fluid power.
2. Mention the different between Hydraulics and Pneumatics
3. Define Pascal law with industrial application
4. Write the importance of Renolds Number
5. Write the Darcy- Equation and its significance
6. What is balanced vane pumps
7. Sketch the pressure vs flow plot of positive and Non-positive pumps
8. Discuss the advantage and disadvantage of fluid power
9. Write the primary functions of hydraulic fluid
10. Discuss the properties of hydraulic fluid.
11. Define absolute and kinematic viscosity
12. Write about positive & non positive displacement pump
13. List the application of fluid power.
14. Name the basic component of hydraulic systems
15. Define Reynold's Number
16. Why the Fluid Power System is called muscle of industry
17. Define Demulsibility.
18. Define neutralization number of hydraulic fluid
19. Write the procedure to calculate the pressure drop in hydraulic circuits
20. Point out any four drawbacks of fluid power systems.
21. Classify the three basic methods of transmitting power

22. List the three basic types of hydraulics fluids
23. Explain the term bulk modulus
24. Summarize the main difference between a open-loop and closed-loop fluid power system
25. List the three basic types of Fluid Power control systems
26. List the application of fluid power in agriculture and aviation industry
27. Conclude that why hydraulic systems are preferred for heavy work than the pneumatic systems.
28. Define viscosity and viscosity index.

PART-B&C

1. Explain in details about the properties of hydraulic fluid
2. Discuss with neat sketch the components of basic hydraulic system and its functions
3. Enumerate and briefly discuss the properties and factors considered the selection of oils
4. Illustrate various type of oil used in power hydraulic system
5. Write the advantages and application of fluid power with respect of fluid power application
6. List out the selection procedure of oil in industrial hydraulic application
7. Explain moody diagram? Write the important characteristics
8. List out the applications of fluid power employed is different industries/fields. List the merits & Demerits of fluid power system
9. Give short notes about various fluids used in the hydraulic systems with advantages and dis advantages
10. Briefly Discuss a operation of a manually operated hydraulic jack
11. State and explain the types of fluid power control system with its advantages?
12. Explain with neat sketch about graphical symbols used in hydraulic system and its function.
13. Explain in details about the various losses in hydraulic fluid power systems
14. Write the short notes about 1. Laminar flow & turbulent flow 2. Energy losses in valves & fittings
3. Darcy's Equation. 4. Pascal's law 5. Renolds Number
15. Discuss the components required for basic hydraulic system? & Mention their functions.
16. Write short notes about types of fluids used in the fluid power systems.
17. How can you measure the frictional losses in Laminar flow and turbulent flow?
18. Explain the working Principle of hydraulic press with neat sketch
19. Write short notes on

1. Neutralization Number
2. Frictional loss in laminar and turbulent flow
20. Explain Bend Axis type of piston pump and loop pump
21. Hydraulic oil of kinematic viscosity 0.9 strokes. Flows through a 35mm diameter pipe at velocity of 4m/s for a length of 100m find the head loss due to friction (in units bar). Assume specific gravity of oil as 0.90
22. State the significance of K-Factor in determining the losses in valves and fittings determine the head loss (in unit bar) across a 40mm wide open gate valve. when hydraulic oil of specific gravity 0.9 flows through it at a rate of 0.015m³/s. The K-Factor for wide open gate valve is 0.19
23. i) How pumps are classified?
ii) Explain with a neat sketch the construction & working principle of Gerotor pump.
24. Explain the working principle of external Gear pump and Internal Gear pump with neat sketch.
25. Explain the working principle of axial piston pumps with neat sketch
26. What are the types of piston pump? Explain the working principle of radial piston pumps with neat sketch
27. Explain the working principle of following pumps with neat sketch
 - i) Lobe pump
 - ii) Screw pump
28. Explain the working principle of unbalanced vane pumps and balanced vane pump with neat sketch
29. Discuss the Performance and efficiency of a pump
30. List out the selection criteria of linear and rotary pumps.

UNIT II**HYDRAULIC ACTUATORS AND CONTROL COMPONENTS****PART-A**

1. Define motor.
2. Define hydraulic actuator
3. Discuss the types of hydraulic actuator.
4. List the application of semi-rotary actuator.
5. Name the different type of cylinder mountings
6. What is the function of unloading and sequence valve
7. Differentiate double rod and tandem cylinder
8. Why do screw pumps create less noise while running

9. Draw ant three Fluid Power ANSI Symbol.
10. List the types of hydraulic cylinder.
11. Explain the term cylinder cushioning
12. Define telescoping cylinder.
13. What is the chattering pressure valve
14. Why end cushions are used in cylinders?
15. How do you select hydraulic pipes for a hydraulic system?
16. Mention the significance of telescopic cylinder with industrial application

PART-B&C

1. Explain the working principle of piston type motor with neat sketch.
2. Explain the working principle semi-rotary actuator with neat sketch..
3. Explain the working of gear type motor and vane type motor
4. Write the short notes on telescopic cylinder
5. Explain the cushioning of cylinder
6. Explain the working principle following types of cylinders
 - i) Single acting cylinder
 - ii) Double acting cylinder
 - iii) Cylinder Cushioning
7. Explain the working principle of different types of cylinders used in hydraulic system
8. Describe the working of double acting tanden cylinder and gear motor with graphical symbol
9. With neat sketch explain the construction of Telescopic cylinder and state its application with example.
10. With a suitable sketch describe the cushioning mechanism used in linear actuators.
11. Explain the construction and operation of basic types of accumulators used in hydraulic system with neat sketch.
12. Explain any three types of special cylinder used in hydraulics with neat sketch
13. List and sketch the fluid power ANSI symbol for the five basic classifications

UNIT III**HYDRAULIC CIRCUITS AND SYSTEMS****PART-A**

1. Name the types of Accumulators & its use
2. Write the function of accumulator
3. What is meant by sizing of accumulator?
4. What is the function of intensifier? Mention the application
5. Discuss the function of an unloading valve.
6. Differentiate between pilot operated and direct operated pressure relief Valve
7. Deduce the purpose of a direction control valve.
8. Where speed control circuit are Required
9. Draw the ANSI symbol for pressure relief valve.
10. How do you classify direction control valves?
11. Discuss the purpose of regenerative circuit.
12. List any four types of Pressure Control Valves.
13. Point out the purpose of a flow control valve.
14. List the functions of a solenoid valve
15. What is the advantages of using sequencing circuit
16. Describe meter-in circuit and where is it used?
17. Describe meter – out circuit and where is it used?
18. Discuss the function of bleed off circuits.
19. Explain the function of relief valve in a hydraulic system
20. Define Electro hydraulic circuit
21. List the arrangements in hydrostatic drives
22. List any four basic types of electronic switches used in electrically controlled fluid power circuits

PART- B&C

1. Design and explain the working of a sequencing circuit.
2. Explain the construction and working of pilot operated sequence valve
3. Explain working and construction of pilot operated pressure relief valve with neat sketch
4. Sketch and explain commonly used 3-position 4-way direction control valves

5. With help of circuit diagram explain types and applications of accumulator
6. Draw and explain the Counter balance valve circuit used in the hydraulic circuit
7. Explain the commonly used electrical control device in fluid power system
8. Explain the construction of pressure relief valve with neat sketch
9. Design the hydraulic press circuit using unloading valve with neat sketch
10. Design and explain the working of a regenerative circuit.
11. Explain the working principle of pressure intensifier, with neat diagram.
12. Draw and explain the Air-over-oil circuit used in the hydraulic circuit.
13. Design the circuit to speed up the extending speed of a double acting cylinder with suitable circuit
14. Describe a hydraulic circuit for synchronizing two cylinder with flow control valves.
15. With suitable sketches explain following industrial hydraulic circuits
 1. Pressure Regulating Circuit
 2. Speed control circuit.
16. Explain the construction and working of following.
 1. Meter in Circuit
 2. Meter out Circuit
17. Discuss the construction and working of a Mechanical hydraulic servo system with a diagram.
18. Develop a circuit having 4/3 DCV regenerative neutral used to control double acting cylinder
19. Discuss the construction and working of a Mechanical hydraulic servo system with a diagram
20. Design and explain the working of Electro hydraulic circuit.
21. Explain the working principle of following
 1. 3/2 Way Valve
 2. 4/2 way valve
 3. 4/3 way valve

UNIT IV

PNEUMATIC AND ELECTRO PNEUMATIC SYSTEMS

PART-A

1. What is FRL Unit
2. Give the standard graphical symbol for FRL unit.
3. Discuss the function of an air filter
4. Point out the purpose of a Pressure regulator.
5. Point out the purpose of a quick Exhaust Valve.
6. Discuss the function at reservoir in a pneumatic system
7. How are logic circuits classified?
8. List the purpose of an Air lubricant.

9. List the purpose of a check Valve.
10. Define bitable flip-flop.
11. How is the speed of a cylinder controlled in pneumatic system?
12. Mention the few applications of air cylinder.
13. Define fluidics.
14. Sketch the graphical symbol of pneumatic regulator.
15. Conclude that why should a lubricator be used in a pneumatic system?
16. Discuss the need of lubricator unit in the pneumatic system.
17. Name the various types of filters used in the pneumatic system
18. Give the truth table for fluidic AND/NAND gate.
19. Discuss the purpose of a quick Exhaust Valve.
20. Classify the pneumatic cylinders based on operating principle.
21. Name four fluid sensors that are used in fluid power system
22. What is the purpose of shuttle valve in pneumatic circuit

PART-B&C

1. Define compressor. Explain the working principle of piston type compressor with neat sketch.
2. With a neat sketch of the pneumatic filter and explain its construction and working.
3. Describe With a neat sketch of the pneumatic Regulator and explain its construction and working.
4. Explain the construction and working principle of Muffler with neat sketch
5. Sketch the graphical symbol and Explain the construction and working principle of FRL Unit with neat sketch
6. Give the empirical rules for sizing the compressor.
7. Explain the construction and working of following control components of FRL
8. Write the procedure for selection and importance of Filter, regulator, Lubricator
9. Write Short Notes of mufflers
10. With neat sketch explain the working principle of a screw compressor
11. Draw and explain the functions of pneumatic check valve.
12. Explain the types of Directional control valve and its construction and operation
13. With a neat sketch of the Quick Exhaust and flow control valve and explain its construction and working
14. Describe pneumatic Actuators and explain the types of linear Actuators.

15. Explain the various types of pneumatic switching with simple sketch
16. Discuss the construction and operation of the basic fluidic devices.
17. Explain the various approaches for entering the program into the PLC.
18. Develop a ladder diagram to perform a drilling operation.
19. Define coanda effect. Discuss how this effect useful to develop a mono stable and bi stable- flip flop device
20. Draw the circuit of control of air cylinder using Flip-Flop and explain it.
21. Discuss the construction and operation of different types of fluid sensors
22. Design an electro pneumatic circuit using cascade method for the following sequences $A^+B^+B^-A^-C^+C^-$
23. Explain the construction and working of following control components 1)check valve 2)Shuttle valve
3) Sequence valve 4) Flow control valve

UNIT V

TROUBLE SHOOTING AND APPLICATIONS

PART-A

1. Define Drilling operation
2. Discuss about shaping operation.
3. Define a low cost automation
4. What is power pack?
5. What is the advantages of servo system
6. What is meant by interlock contacts?
7. Mention any two roles of pneumatic systems in low cost automation?
8. What do you understand by single shot sequencing?
9. what are the important components of a hydraulic power pack
10. what is the function of air filter and dryer
11. differentiate temperature switch and pressure switch
12. when to use timer and relay ? why
13. what is ladder diagram
14. state any four advantages of pneumatic circuits
15. state the application of pneumatic system
16. Name any two faults that can be found in hydraulic systems.

PART-B&C

1. Explain the ladder logic diagram with an example
2. Design a pneumatic circuit for the following sequence using cascade method A+B+B-A- where the + cylinder extraction and – cylinder retraction.
3. Design a pneumatic circuit using cascade method for the sequence A+ A- B+ B- and explain its working principle.
4. Explain in detail about how the failure and trouble shooting is carried out in hydraulic system
5. Explain in detail about Various selection criteria for pneumatic components
6. Design and draw an electro hydraulic pneumatic circuit for the sequence. A+ B+B- A-.
Also write a ladder diagram.
7. List out any seven types of faults that can be found in pneumatic system. Also write the remedial actions for the faults
8. Design a pneumatic circuit for the following sequence using cascade method A+B+A-B- where the + cylinder extraction and – cylinder retraction
9. Describe the basic concepts of low cost automation with suitable example.
10. Discuss the use of microprocessors in hydraulic and pneumatic systems
11. Explain in detail about how the failure and trouble shooting is carried out in pneumatic system
12. Design and develop a robot system to pick and place object.
13. Design and develop the coin operated barriers of a car park.
14. Draw and explain a hydraulic circuit to actuate a shaping machine ram. Incorporate the following features
In the circuit.
 - i. Rapid tool approach
 - ii. Slow cutting and
 - iii. Rapid tool retraction/ return.
15. Design and draw a circuit using the hydraulic components for the shaping operation
16. Design and draw a circuit using the hydraulic components for the Drilling operation.
17. Design a circuit using the hydraulic components for the Punching & press operation.

*****Wish You Happy Learning*****