

KONGUNADU COLLEGE OF ENGINEERING AND TECHNOLOGY
Namakkal - Trichy Main Road, Thottiam, Trichy
DEPARTMENT OF MECHANICAL ENGINEERING
ME8694-HYDRAULICS AND PNEUMATICS

UNITS NOTES

UNIT-I FLUID POWER PRINCIPLES AND HYDRAULIC PUMPS

Introduction:

Typical hydraulic circuits for control of industrial machinery are described in this lesson. Graphical hydraulic circuit diagrams incorporating component symbols are used to explain the operation of the circuits.

Basic Components of a Hydraulic System:

Hydraulic systems are power-transmitting assemblies employing pressurized liquid as a fluid for transmitting energy from an energy-generating source to an energy-using point to accomplish useful work.

Figure 1.1 shows a simple circuit of a hydraulic system with basic components.

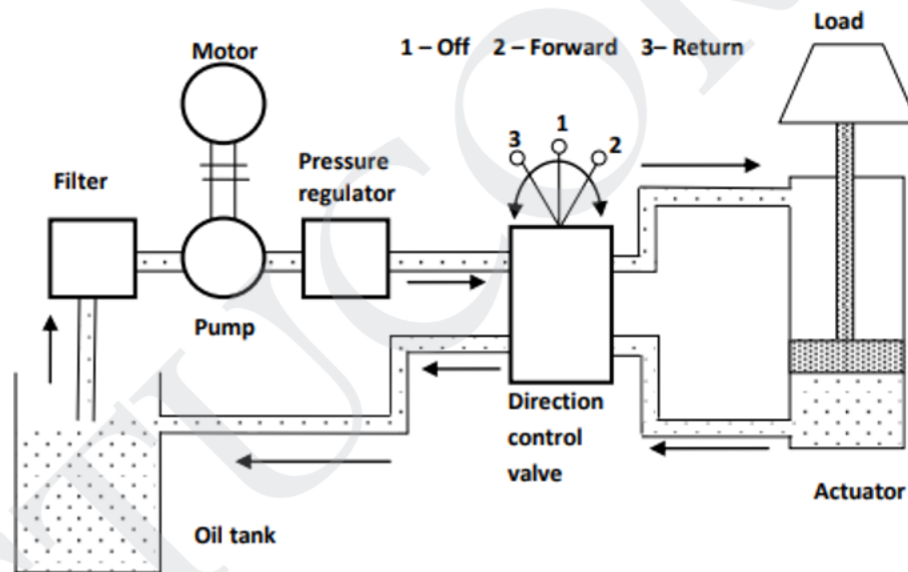

Hydraulic System

Functions of the components shown are as follows:

- The hydraulic actuator is a device used to convert the fluid power into mechanical power to do useful work.
- The actuator may be of the linear type (e.g., hydraulic cylinder) or rotary type (e.g., hydraulic motor) to provide linear or rotary motion, respectively.
- The hydraulic pump is used to force the fluid from the reservoir to rest of the hydraulic circuit by converting mechanical energy into hydraulic energy.

The word “hydraulics” generally refers to power produced by moving liquids. Modern hydraulics is defined as the use of confined liquid to transmit power, multiply force, or produce motion.

- Valves are used to Pressure regulator
- External power supply (motor) is required to drive the pump.
- Reservoir is used to hold the hydraulic liquid, usually hydraulic oil.
- Piping system carries the hydraulic oil from one place to another.
- Filters are used to remove any foreign particles so as keep the fluid system clean and efficient, as well as avoid damage to the actuator and valves.
- Pressure regulator regulates (i.e., maintains) the required level of pressure in the hydraulic fluid.

The piping is of closed-loop type with fluid transferred from the storage tank to one side of the piston and returned back from the other side of the piston to the tank.

Fluid is drawn from the tank by a pump that produces fluid flow at the required level of pressure. If the fluid pressure exceeds the required level, then the excess fluid returns back to the reservoir and remains there until the pressure acquires the required level. Control the direction, pressure and flow rate of a fluid flowing through the circuit. Motor 1 – Off 2 – Forward 3– Return 3 2 1 Load Direction control valve Pump Oil tank Filter Actuator.

Applications of Hydraulic Systems:

The chief advantage that hydraulic systems derive is from the high pressures that can be applied leading to high force or torque by the actuating piston or motor.

Pressures normally used in Industry are 140 bar (140 kgf/ cm² ≈14 MPA ≈ 2000 psi). But in some specific applications in machine tools and aerospace, 350 bar (35 MPA or 5000 psi) is also common.

Example: Consider an actuator with a 10 cms diameter piston. If the pressure applied on the piston is 140 bar, Force that the piston rod delivers

$$F = \text{Pressure} \times \text{Area} = 140 * \pi/4 * 10^2 = 10,996 \text{ Kgf} = 108 \text{ KN.}$$

ie nearly 10 Tons of load can be applied using a 10 cms dia cylinder. If the pressure is 350 bar, load will be 25 Tons.

Similarly high torques can be applied with a small sized motor compared to an electric motor. The high Power / Weight ratio of the hydraulic actuators is the prime reason for use of hydraulics.

Application areas:

Hydraulic systems are generally used for precise control of larger forces. The main applications of

hydraulic system can be classified in five categories:

Industrial: Plastic processing machineries, steel making and primary metal extraction applications, automated production lines, machine tool industries, paper industries, loaders, crushes, textile machineries, R & D equipment and robotic systems etc.

Advantages of Hydraulic systems:

- High power to weight ratio compared to electrical systems
- Allows easy control of speed and position, and direction
- Facilitates stepless power control
- Allows combination with electric controls
- Delivers consistent power output which is difficult in pneumatic or mechanical drive systems
- Performs well in hot environment conditions
- Compared to Pneumatics:
- Much stiffer (or rigid) due to incompressible fluid
- Better speed of response
- Better lubricity (less friction) and rust resistance
- Low maintenance cost.

Disadvantages:

Material of storage tank, piping, cylinder and piston can be corroded with the hydraulic fluid. Therefore one must be careful while selecting materials and hydraulic fluid.

Structural weight and size of the system is more which makes it unsuitable for the smaller instruments.

Small impurities in the hydraulic fluid can permanently damage the complete system. Therefore suitable filter must be installed.

Leakage of hydraulic fluid is also a critical issue and suitable prevention method and seals must be adopted. Hydraulic fluids, if not disposed properly, can be harmful to the environment.

Relative advantages of different power transmission systems:

Each type of power transmission and control system has specifically suitable application areas. However, we can make some general comparisons between them.

Fluid power and Electrical are good at transmitting power over long distances, and also better controllable compared to mechanical devices. Electrical devices are the cheapest. Hydraulic systems have better

power/weight ratio. In terms of cost, electrical would be the cheapest.

Following table gives a relative comparison of Hydraulic, pneumatic and Mech / EM systems. H –

Hydraulic; P – Pneumatic M – Mechanical/Electromechanical; E – Electrical

Hydraulic fluids: The general requirements of fluids in power transmission are:

- Low cost
- Non-corrosive
- Have infinite stiffness
- Good lubrication properties
- Store well without degradation
- Non-toxic
- Non-inflammable
- Properties remain stable over wide range of temperatures.

Many types of fluids are used ranging from water, mineral oils, vegetable oils, synthetic and organic liquids. Water was the first liquid used and is very cheap. But its disadvantages are – freezes easily, rusts metal parts, boils and relatively poor lubricant. Mineral oils are far superior in these properties. Its success also lies in – the ease with which their properties can be changed with additives.

Additives used are - various chemicals like phenols and amines, chlorine and lead compounds, esters, organo-metallic compounds, for change in properties such as:

- Antioxidants
- Corrosion inhibitor
- Rust inhibitor
- Anti-foam
- Lubrication improver
- Pour point depressant
- Viscosity index improver.

FILTERS:

When hydraulic fluids are contaminated, hydraulic systems may get damaged and malfunction due to clogging and internal wear . They require filtration to remove contaminants.

Filters are classified as

- Line filters
- Off-line filters
- Other cleaning equipment

Reservoir filters: These may be installed in the reservoir at the pump suction port or in the return line cleaning the liquid returning to the port.

Suction type filter: consists of a core rolled up with a filter paper and submerged in working fluid.

Typically they use 100 micron filter papers.

Return filters or either mounted on the reservoir or in the lines.

Filtration ratings in return lines vary from 10 micron to 35 micron, lower micron rating being used for higher pressures.

Line filters: These are installed when high filtration is required and are used to avoid high suction at the reservoir filters. These are used with a separate line connection. Filter selection depends upon pressure, flow rate and filtration rating.

Off-line filters: These filters clean fluids in a reservoir using a dedicated pump and filter separate from the line. These are used when higher cleaning level is required.

Other equipment include air breather (filtering out dust in the air), oil filling port or magnetic separator to absorb iron powders in reservoir.

ACCUMULATORS:

These are used to supply additional fluid when main line fluid pump is inadequate to perform the actuation. Usually gas filled bladders at high pressure act on the reservoir of fluid in the accumulator to make up for the required line flow.

- Accumulators are used to accommodate large flow rates or to compensate leakages.
- Absorb pulsations and reducing noise
- To absorb shocks.

HEAT EXCHANGERS:

Energy generated by prime movers transforms to thermal energy which increases the temperature of the working fluid. High temperatures deteriorate the fluid properties and result in shorter fluid life. Hence it is required to cool the oil to certain level for smooth operation.

Typical heat exchangers used are:

Tubular heat exchangers: This delivers cooling fluid through copper tubes to accomplish heat exchange between fluid and cooling water.

Plate heat exchanger: This consists of many thin cooling plates which exchange heat with cooling water.

Air cooling radiator: Forced air flows through tubes and cools the fluid

Refrigerant exchanger: This is like a domestic refrigerator and dissipates heat from fluid. It consists of a hydraulic pump, a motor and thermostat. It is used when accurate temperature control is needed.

Heaters: In cold regions, viscosity becomes high causing high pressure loss in the system. Hence electronic heater or steam heaters are used for heating the oil to the desired temperature.

2 Pumps:

Pumps used in hydraulic systems are Positive displacement pumps.

(Rotodynamic pumps like centrifugal pump are not used)

Most commonly used pumps are

- Gear Pump (External or Internal),
- Vane Pump
- Piston pump (Axial – Regular or Bent Axis type).

Points to Note about Pumps:

- Positive displacement pumps
- generate high pressures,
- high volumetric efficiency,
- high power to weight ratio,
- have little change in efficiency throughout the pressure range
- have wide operating range pressure and speed.

Gear Pumps:

Gear pump is a robust and simple positive displacement pump. It has two meshed gears revolving about their respective axes. These gears are the only moving parts in the pump. They are compact, relatively inexpensive and have few moving parts.

Gear pumps are most commonly used for the hydraulic fluid power applications and are also widely used in chemical industries.

Based upon the design, the gear pumps are classified as:

- Lobe pumps
- Internal gear pumps
- Gerotor pumps

External gear pump:

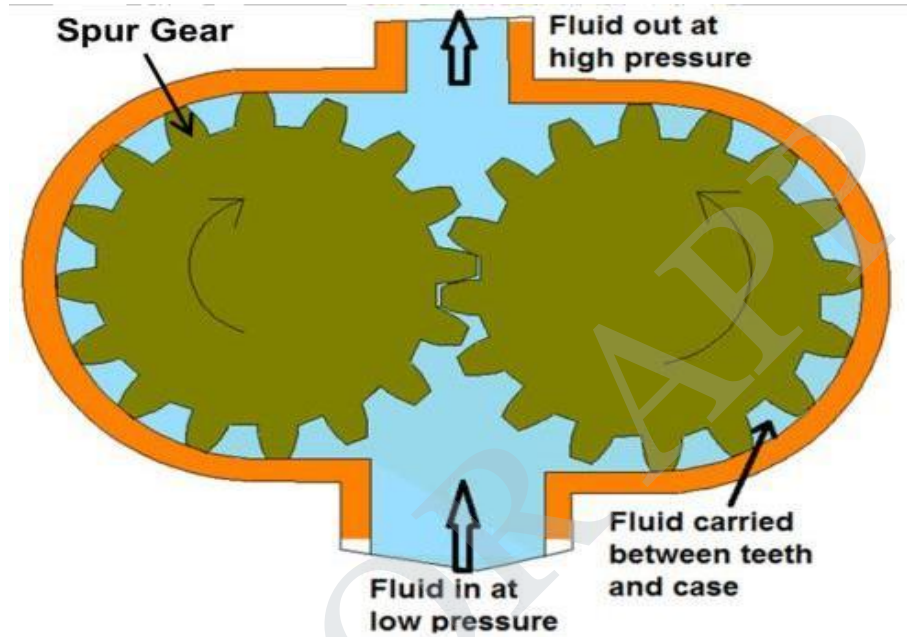

Lobe Pump:

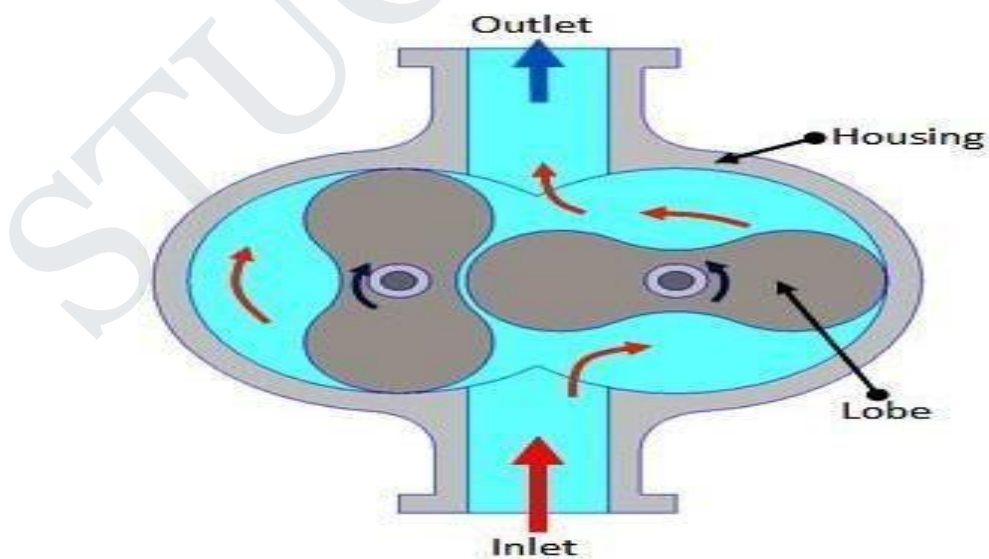

Working: One of the two gears / lobes is connected to a motor and causes rotation of the other. As they rotate in the direction shown, vacuum is created on the inlet side, liquid is trapped between the gear teeth / lobe and the motor casing. On further rotation liquid is forced to the outlet side. The gear teeth or lobes at the centre provide a seal between the inlet and outlet.

The volume displaced (dp) is product of the area entrapped and width of tooth per each revolution and is constant. Flow rate is $N \times dp$, where N is the speed of motor. (use appropriate units).

Internal Gear Pump:

Working: The internal gear is eccentric to the outer gear. Rotation of the internal gear causes suction on inlet side, liquid is trapped between internal gear teeth and the crescent seal, and is forced out to outlet port.

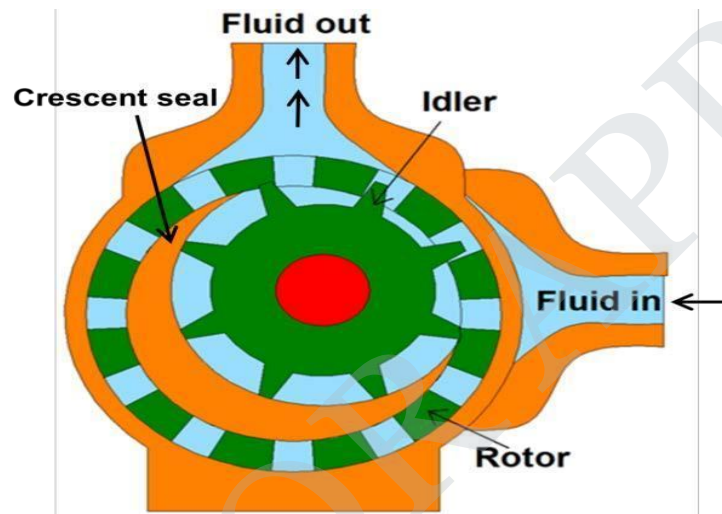

Internal gear pumps are exceptionally versatile. They are often used for low or medium viscosity fluids such as solvents and fuel oil and wide range of temperature. This is non-pulsing, self-priming and can run dry for short periods. It is a variation of the basic gear pump.

Vane Pumps:

Gear pumps have a disadvantage of small leakage due to gap between gear teeth and the pump housing. This limitation is overcome in vane pumps.

Working principle: The schematic of vane pump working principle is shown in figure. Vane pumps generate a pumping action by tracking of vanes along the casing wall.

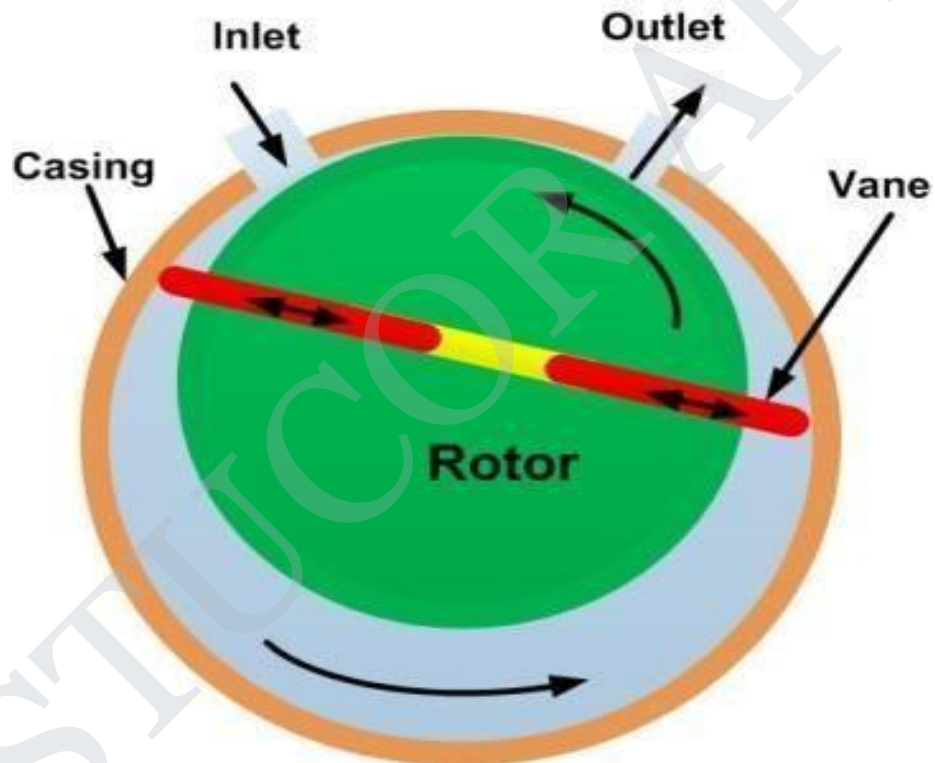

The vane pumps generally consist of a rotor, vanes, ring and a port plate with inlet and outlet ports. The rotor in a vane pump is connected to the prime mover through a shaft. The vanes are located on the slotted rotor. The rotor is eccentrically placed inside a cam ring as shown in the figure. The rotor is sealed into the cam by two side plates. When the prime mover rotates the rotor, the vanes are thrown outward due to centrifugal force. The vanes track along the ring. It provides a tight hydraulic seal to the fluid which is more at the higher rotation speed due to higher centrifugal force.

Unbalanced Vane pump:

In practice, the vane pumps have more than one vane as shown in figure

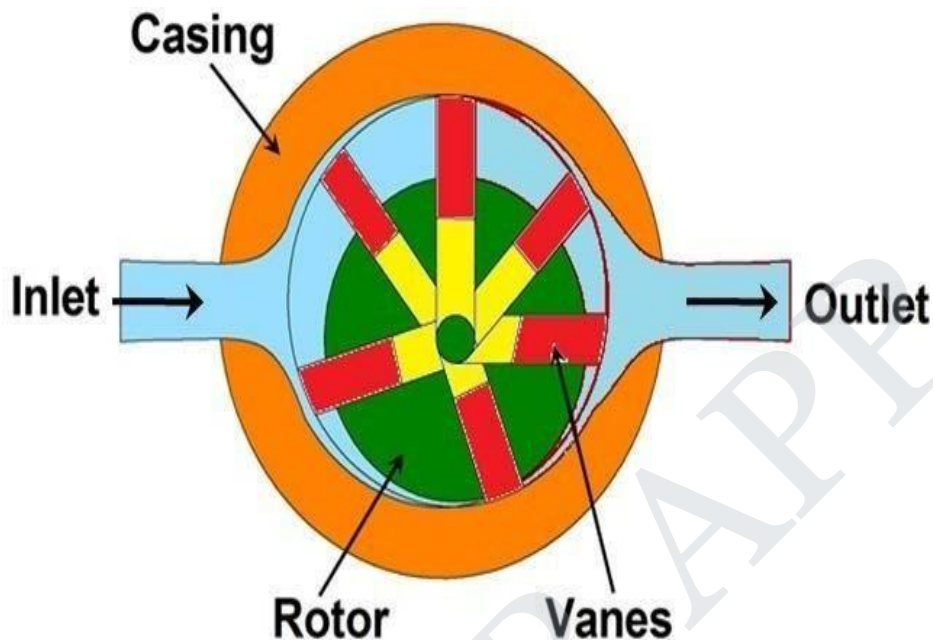

The rotor is offset within the housing, and the vanes are constrained by a cam ring as they cross inlet and outlet ports. Although the vane tips are held against the housing, still a small amount of leakage exists between rotor faces and body sides. This type of pump is called as unbalanced vane pump.

Balanced vane pump:

This pump has an elliptical cam ring with two inlet and two outlet ports. Pressure loading still occurs in the vanes but the two identical pump halves create equal but opposite forces on the rotor. It leads to the zero net force on the shaft and bearings. Thus life of pump and bearing increase significantly. Also the sound and vibration are less.

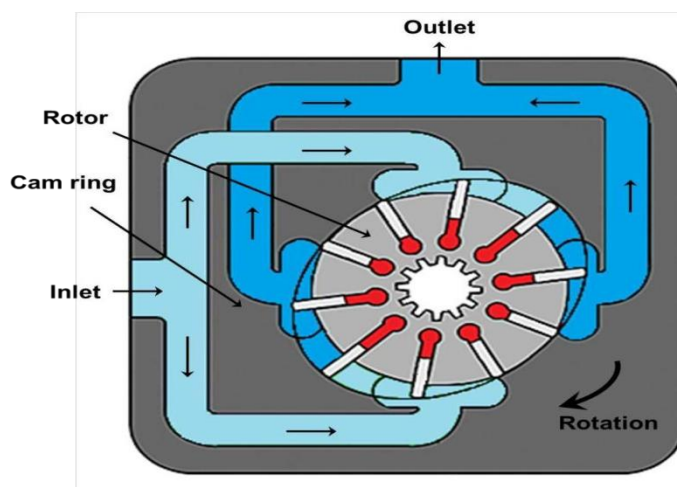

Balanced Vane Pump

Axial Piston Pump:

Axial piston pumps are positive displacement pumps which convert rotary motion of the input shaft into an axial reciprocating motion of the pistons. These pumps have a number of pistons (usually an odd number) in a circular array within a housing which is commonly referred to as a cylinder block, rotor or barrel. In general, these systems have a maximum operating temperature of about 120 °C. Therefore, the leakage between cylinder housing and body block is used for cooling and lubrication of the rotating parts. This cylinder block rotates by an integral shaft aligned with the pistons.

There are two types of axial piston pumps.

- Bent axis piston pumps.
- Swash plate axial piston pump

1. Bent-Axis Piston Pump:

In these pumps, the reciprocating action of the pistons is obtained by bending the axis of the cylinder block. The cylinder block rotates at an angle which is inclined to the drive shaft. The cylinder block is turned by the drive shaft through a universal link. The cylinder block is set at an offset angle with the drive shaft. The cylinder block contains a number of pistons along its periphery. These piston rods are connected with the drive shaft flange by ball-and-socket joints. These pistons are forced in and out of their bores as the distance between the drive shaft flange and the cylinder block changes.

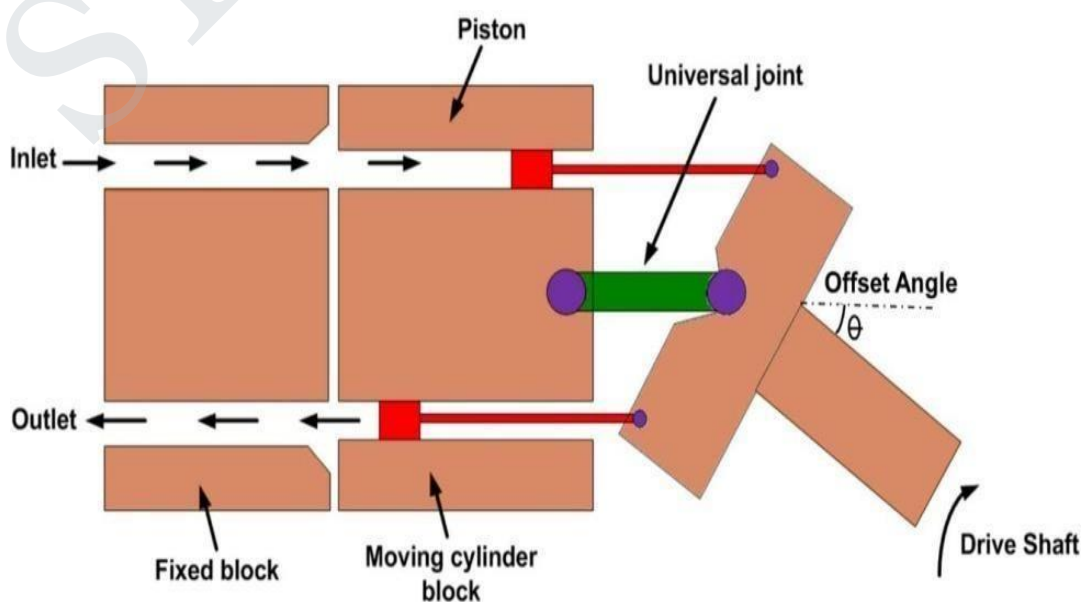

Bent Axis Piston pump

The volumetric displacement (discharge) of the pump is controlled by changing the offset angle.

Swash Plate Axial Piston Pump:

A swash plate is a device that translates the rotary motion of a shaft into the reciprocating motion. It consists of a disk attached to a shaft as shown in Figure. If the disk is aligned perpendicular to the shaft; the disk will turn along with the rotating shaft without any reciprocating effect. Similarly, the edge of the inclined shaft will appear to oscillate along the shaft's length. This apparent linear motion increases with increase in the angle between disk and the shaft (offset angle).

The apparent linear motion can be converted into an actual reciprocating motion by means of a follower that does not turn with the swash plate.

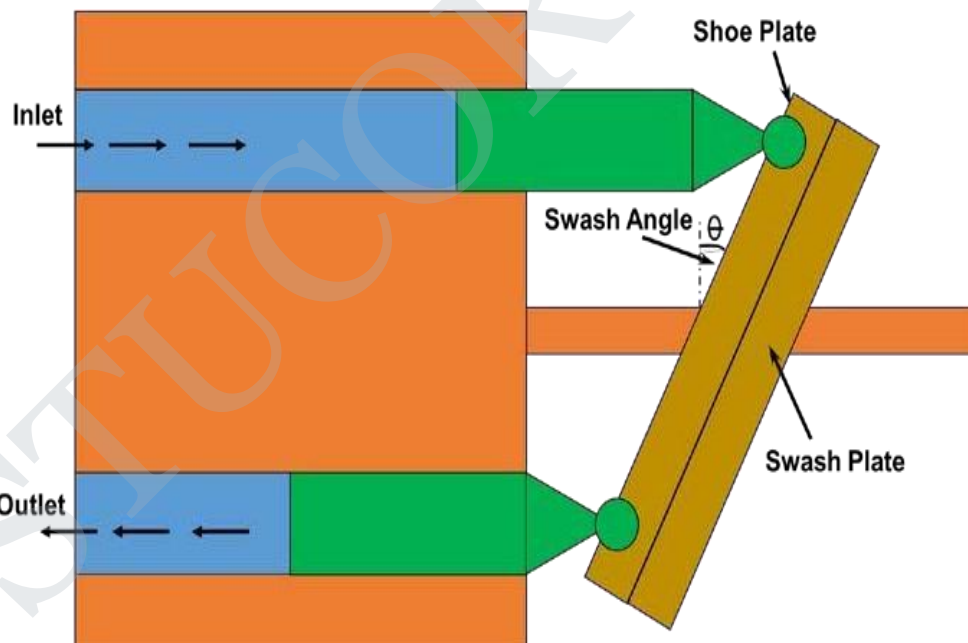

Swash plate piston pump:

In swash plate axial piston pump a series of pistons are aligned coaxially with a shaft through a swash plate to pump a fluid. The axial reciprocating motion of pistons is obtained by a swash plate that is either fixed or has variable degree of angle. As the piston barrel assembly rotates, the piston rotates around the shaft with the piston shoes in contact with the swash plate. The piston shoes follow the angled surface of the swash plate and the rotational motion of the shaft is converted into the reciprocating motion of the pistons.

Pump capacity can be controlled by varying the swash plate angle with the help of a separate hydraulic

cylinder.

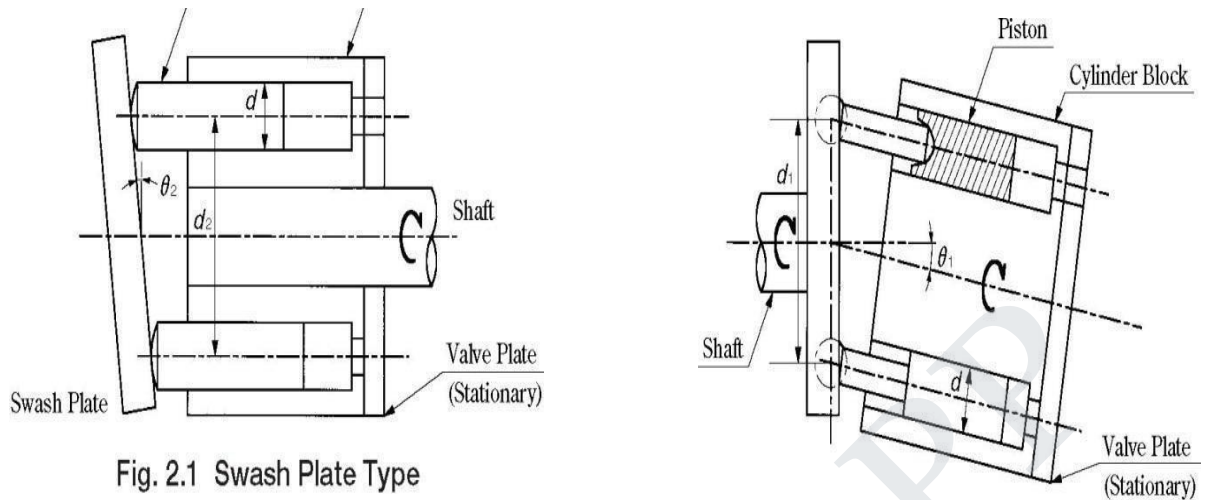
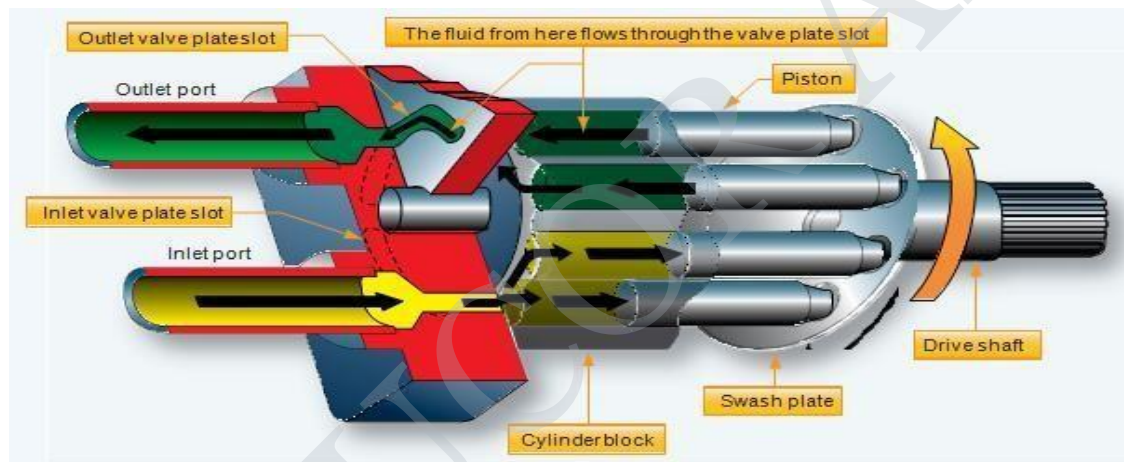

Fig. 2.1 Swash Plate Type



PUMP

Introduction:

The function of a pump is to convert mechanical energy into hydraulic energy. It is the heart of any hydraulic system because it generates the force necessary to move the load. Mechanical energy is delivered to the pump using a prime mover such as an electric motor. Partial vacuum is created at the inlet due to the mechanical rotation of pump shaft. Vacuum permits atmospheric pressure to force the fluid through the inlet line and into the pump. The pump then pushes the fluid mechanically into the fluid power actuated devices such as a motor or a cylinder.

Pumps are classified into three different ways and must be considered in any discussion of fluid

power equipment.

Classification based on displacement:

- Non-positive displacement pumps (hydrodynamic pumps).
- Positive displacement pumps (hydrostatic pumps).
- Classification based on delivery:
- Constant delivery pumps.
- Variable delivery pumps.

Classification based on motion:

- Rotary pump.
- Reciprocating pump.

Classification of Pumps:

Classification Based on Displacement;

Non-Positive Displacement Pumps:

Non-positive displacement pumps are primarily velocity-type units that have a great deal of clearance between rotating and stationary parts. Non-displacement pumps are characterized by a high slip that increases as the back pressure increases, so that the outlet may be completely closed without damage to the pump or system. Non-positive pumps do not develop a high pressure but move a large volume of fluid at low pressures. They have essentially no suction lift. Because of large clearance space, these pumps are not self-priming. In other words, the pumping action has too much clearance space to seal against atmospheric pressure. The displacement between the inlet and the outlet is not positive. Therefore, the volume of fluid delivered by a pump depends on the speed at which the pump is operated and the resistance at the discharge side. As the resistance builds up at the discharge side, the fluid slips back into the clearance spaces, or in other words, follows the path of least resistance. When the resistance gets to a certain value, no fluid gets delivered to the system and the volumetric efficiency of the pump drops to zero for a given speed. These pumps are not used in fluid power industry as they are not capable of withstanding high pressure. Their maximum capacity is limited to 17–20 bar. These types of pumps are primarily used for transporting fluids such as water, petroleum, etc., from one location to another considerable apart

The advantages are as follows:

- Non-displacement pumps have fewer moving parts,
- Initial and maintenance cost is low,
- They give smooth continuous flow,
- They are suitable for handling almost all types of fluids including slurries and sledges,
- Their operation is simple and reliable.

The disadvantages are as follows:

- Non-displacement pumps are not self-priming and hence they must be positioned below the fluid level,
- Discharge is a function of output resistance,
- Low volumetric efficiency

Positive Displacement Pump:

Positive displacement pumps in contrast have very little slips, are self-priming and pump against very high pressures, but their volumetric capacity is low. Positive displacement pumps have a very close clearance

between rotating and stationary parts and hence are self- priming. Positive displacement pumps eject a fixed amount of fluid into the hydraulic system per revolution of the pump shaft. Such pumps are capable of overcoming the pressure resulting from mechanical loads on the system as well as the resistance of flow due to friction. This equipment must always be protected by relief valves to prevent damage to the pump or system. By far, a majority of fluid power pumps fall in this category, including gear, vane and piston pumps. Performance curves for positive and non-positive displacement pumps.

Positive displacement pumps are classified based on the following characteristics:

Type of motion of pumping element: Based on the type of motion of pumping element, positive
Fixed displacement pumps.

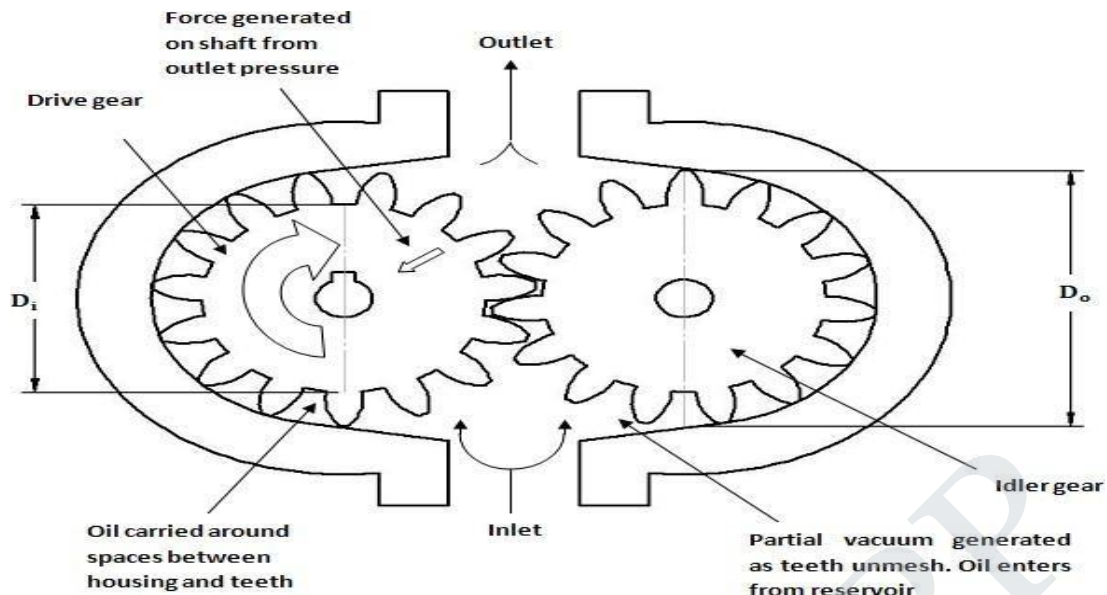

Operation of an external gear pump

Internal Gear Pumps:

Another form of gear pump is the internal gear pump. They consist of two gears. An external gear and an internal gear. The crescent placed in between these acts as a seal between the suction and discharge. When a pump operates, the external gear drives the internal gear and both gears rotate in the same direction. The fluid fills the cavities formed by the rotating teeth and the stationary crescent.

Both the gears transport the fluid through the pump. The crescent seals the low-pressure pump inlet from the high-pressure pump outlet. The fluid volume is directly proportional to the degree of separation and these units may be reversed without difficulty. The major use for this type of pump occurs when a through shaft is necessary, as in an automatic transmission. These pumps have a higher pressure capability than external gear pumps.

Lobe Pumps:

The operation of lobe pump shown is similar to that of external gear pump, but they generally have a higher volumetric capacity per revolution. The output may be slightly greater pulsation because of the smaller number of meshing elements.

Lobe pumps, unlike external gear pumps, have both elements externally driven and neither element has any contact with the other. For this reason, they are quieter when compared to other types of gear pumps. Lobe contact is prevented by external timing gears located in the gearbox. Pump shaft support bearings are located in the gearbox, and because the bearings are out of the pumped liquid, pressure is limited by bearing location and shaft deflection. They do not lose efficiency with use. They are similar to external gear pumps with respect to the feature of reversibility.

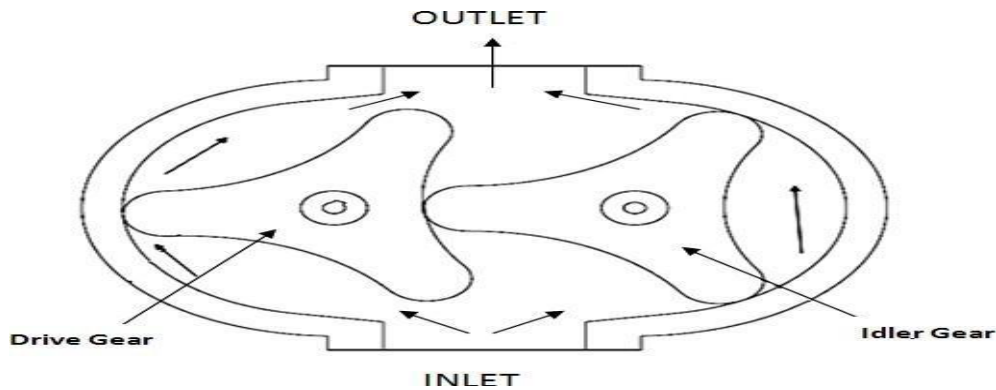

Stages of operation of Lobe pump:

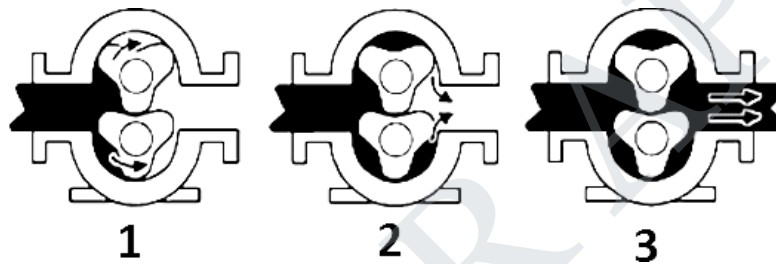

As the lobes come out of mesh, they create expanding volume on the inlet side of the pump. Liquid flows into the cavity and is trapped by the lobes as they rotate. Liquid travels around the interior of the casing in pockets between the lobes and the casing (it does not pass between the lobes). Finally, the meshing of the lobes forces the liquid through the outlet port under pressure. Lobe pumps are frequently used in food applications because they are good at handling solids without inflicting damage to the product. Solid particle size can be much larger in lobe pumps than in other positive displacement types. Because lobes do not make contact, and clearances are not as close as in other positive displacement pumps, this design handles low-viscosity liquids with diminished performance. Loading characteristics are not as good as other designs and suction ability is low. High-viscosity liquids require reduced speeds to achieve satisfactory performance. Reductions of 25% of rated speed.

Advantages:

The advantages of lobe pumps are as follows:

- Lobe pumps can handle solids, slurries, pastes and many liquid.
- No metal-to-metal contact.
- Superior CIP (Cleaning in Place) /SIP (Sterilization in Place) capabilities.

- Long-term dry run (with lubrication to seals).
- Non-pulsating discharge.

Disadvantages:

The disadvantages of lobe pumps are as follows:

- Require timing gears.
- Require two seals.
- Reduced lift with thin liquids.

Applications:

Common rotary lobe pump applications include, but are not limited to the following:

- Polymers,
- Paper coatings,
- Soaps and surfactants,
- Paints and dyes,
- Rubber and adhesives,
- Pharmaceuticals,
- Food applications.

Screw Pumps:

These pumps have two or more gear-driven helical meshing screws in a closefitting casing to develop the desired pressure. These screws mesh to form a fluid-type seal between the screws and casing. A schematic diagram of a screw pump. A two-screw pump consists of two parallel rotors with inter-meshing threads rotating in a closely machined casing. The driving screw and driven screw are connected by means of timing gears. When the screws turn, the space between the threads is divided into compartments. As the screws rotate, the inlet side of the pump is flooded with hydraulic fluid because of partial vacuum. When the screws turn in normal rotation, the fluid contained in these compartments is pushed uniformly along the axis toward the center of the pump, where the compartments discharge the fluid. Here the fluid does not rotate but moves linearly as a nut on threads. Thus, there are no pulsations at a higher speed; it is a very quiet operating pump. In a screw pump, a chamber is formed between thread and housing.

Principle Used in Hydraulic Actuator System:**Pascal's Law:**

Pressure applied to a confined fluid at any point is transmitted undiminished and equally throughout the fluid in all directions and acts upon every part of the confining vessel at right angles to its interior surfaces. **Amplification of Force:**

Since pressure P applied on an area A gives rise to a force F , given as, $F = P \times A$ Thus, if a force is applied over a small area to cause a pressure P in a confined fluid, the force generated on a larger area can be made many times larger than the applied force that created the pressure.

Conservation of Energy:

Since energy or power is always conserved, amplification in force must result in reduction of the fluid velocity. Indeed if the resultant force is applied over a larger area then a unit displacement of the area would cause a larger volumetric displacement than a unit displacement of the small area through which the generating force is applied. Thus, what is gained in force must be sacrificed in distance or speed and power would be conserved.

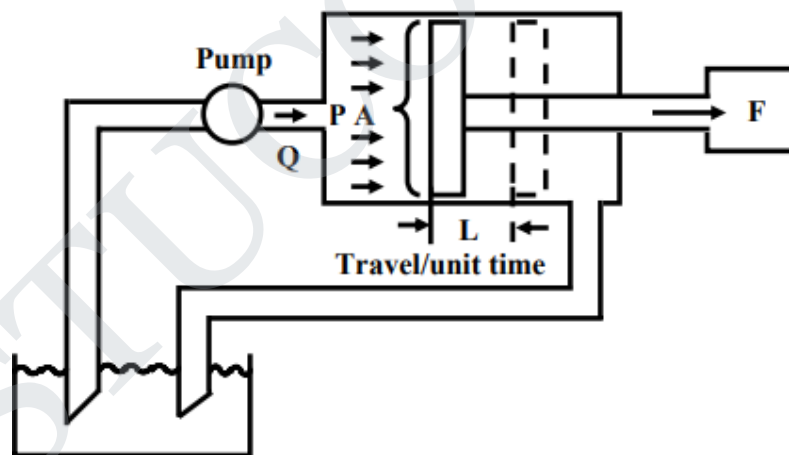

Fig. 26.1 Major hydraulic and mechanical variables

pump. However, the mechanical equipment cannot be coupled directly to the prime mover because the required control over the motion, necessary for industrial operations cannot be achieved. In terms of these Hydraulic Actuation Systems offer unique advantages, as given below.

Variable Speed and Direction:

Most large electric motors run at adjustable, but constant speeds. It is also the case for engines. The actuator (linear or rotary) of a hydraulic system, however, can be driven at speeds that vary by large amounts and fast, by varying the pump delivery or using a flow control valve. In addition, a hydraulic

other prime movers.

Power-to-weight ratio:

Hydraulic components, because of their high speed and pressure capabilities, can provide high power output with very small weight and size, say, in comparison to electric system components. Note that in electric components, the size of equipment is mostly limited by the magnetic saturation limit of the iron. It is one of the reasons that hydraulic equipment finds wide usage in aircrafts, where dead-weight must be reduced to a minimum.

Stall Condition and Overload Protection:

A hydraulic actuator can be stalled without damage when overloaded, and will start up immediately when the load is reduced. The pressure relief valve in a hydraulic system protects it from overload damage.

During stall, or when the load pressure exceeds the valve setting, pump delivery is directed to tank with definite limits to torque or force output. The only loss encountered is in terms of pump energy. On the contrary, stalling an electric motor is likely to cause damage. Likewise, engines cannot be stalled without the necessity for restarting.

Point to Ponder: 2

Consider two types of variable speed drives:

In the first one an electric motor with a power electronic servo drive is directly coupled to the load through a mechanism. In the second one an electric motor with a constant speed drive drives the pump in a hydraulic system which provides the variable speed drive to the load. Which one of these two is more energy efficient.

Table 2.1 Characteristics of the Pumps

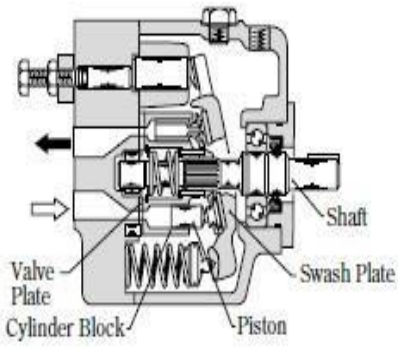
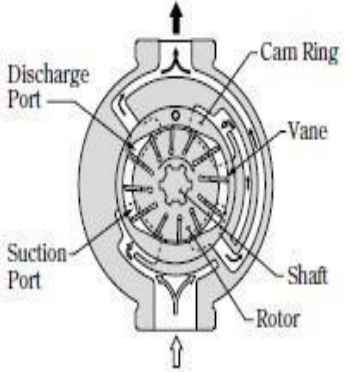
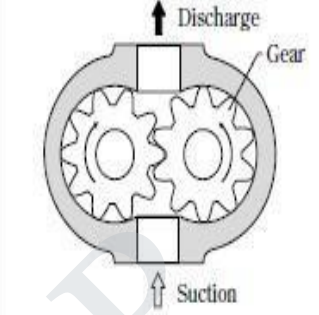
Type	Piston Pumps	Vane Pumps	Gear Pumps
Structure			
Operation Principle	Expansion and compression of a volume in a cylinder block with the piston stroke	Expansion and compression of volumes between the vanes and the cam ring	Movement of volumes between tooth spaces and the casing (the external gear pump is shown.)
Efficiency	<ul style="list-style-type: none"> • Generally the highest. • The valve plate is easily damaged and efficiency drops as the plate wears out. 	<ul style="list-style-type: none"> • Generally low. • Can be compensated when the vane wears out. 	<ul style="list-style-type: none"> • Generally low. • Drops as the gear wears out.
Contamination Resistance	Highly susceptible to foreign substances in oil.	Susceptible to foreign substances in oil, but less so than piston pumps.	Susceptible to foreign substances in oil, but hardly susceptible when the pumps are low pressure types.
Suction Ability	Low.	Middle.	High.
Variable Displacement Type	Easy to convert by changing the angle of the swash plate or bent axis.	Can be converted by changing the eccentricity of the cam ring for the unbalanced type.	Difficult.
Size and price	Generally large, heavy, and expensive.	Smallest and relatively inexpensive.	Small, light, and inexpensive.

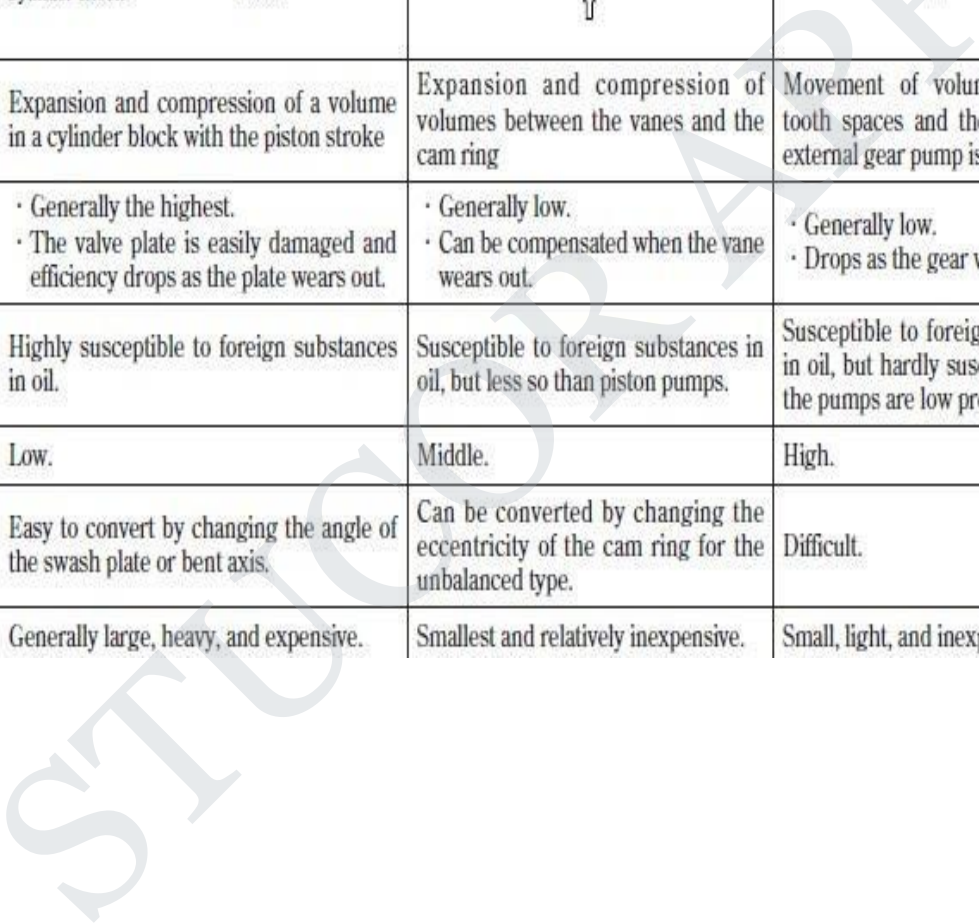

UNIT -II HYDRAULIC ACTUATORS AND CONTROL COMPONENTS

DIRECTIONAL CONTROL VALVES (DCV):

Directional control valves can be classified in a number of ways:

According to type of construction:

- Poppet valves
- Spool valves

According to number of working ports:

- Two- way valves
- Three – way valves
- Four- way valves.

According to number of switching position:

- Two – position
- Three - position

According to Actuating mechanism:

- Manual actuation
- Mechanical actuation
- Solenoid (Electrical) actuation
- Hydraulic (Pilot) actuation
- Pneumatic actuation
- Indirect actuation

The designation of the directional control valve refers to the number of working ports and the number of switching positions.

How to read the valve schematic:

Symbols: P – Pressure port (high pressure oil inlet from pump) T – Tank or return port connected to tank
A,B – Ports connected to actuator (eg., piston side and rod side of cylinder) The figure below represents a 2 position, 4-way (or 4- port) valve .

The two rectangular blocks represent two positions of possible actuation of valve. A,B,P and T are the 4 ports of the valve connected to different components. Hence it is called a 2/4 valve.

The construction or design of the valve is such that when valve is actuated to left side, as shown by

arrows, pressure line from pump is connected to A side of actuator, and B side is connected to the tank.

Similarly when valve is switched to second position, the right side is effective. (Now read the four symbols A,B,P,T on the four ports in right rectangle, which is effective). From the arrows it means P is connected to B and A is connected to T).

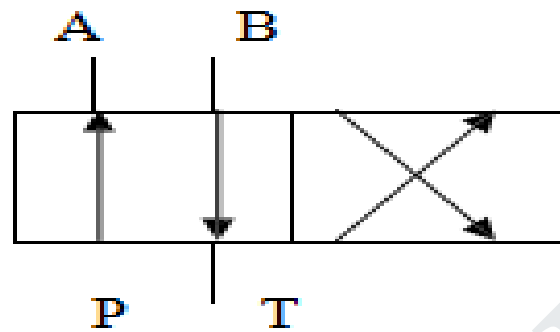
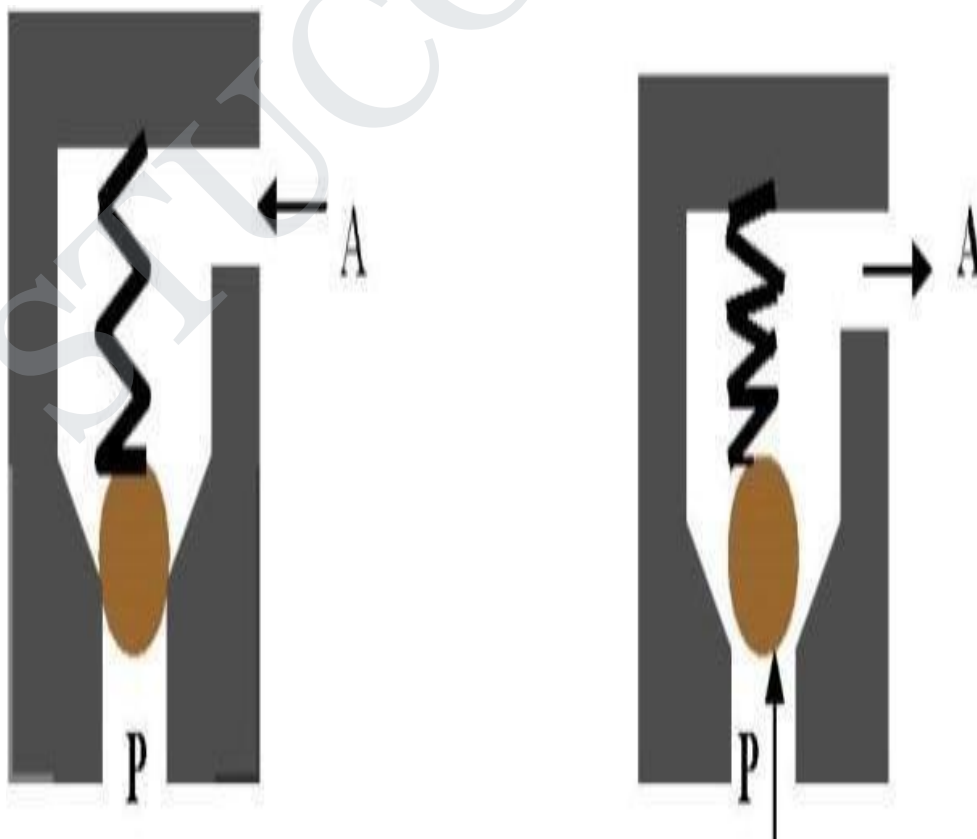

Fig 4.3 2 / 4 valve symbol

Check Valve: This valve allows flow from P to A., when pressure is enough to overcome the spring force acting on the ball, which is quite small. It does not allow flow in the other direction ie from A to P.

The symbol for check valve is as shown. It is also called On-off or Non-return valve.



The simplest type of directional control valve is a check valve which is a two way valve because it contains two ports. These valves are also called as on-off valves because they allow the fluid flow in only in one direction and the valve is normally closed. Two-way valves is usually the spool or poppet design with the poppet.

Spool type on/ off valve:

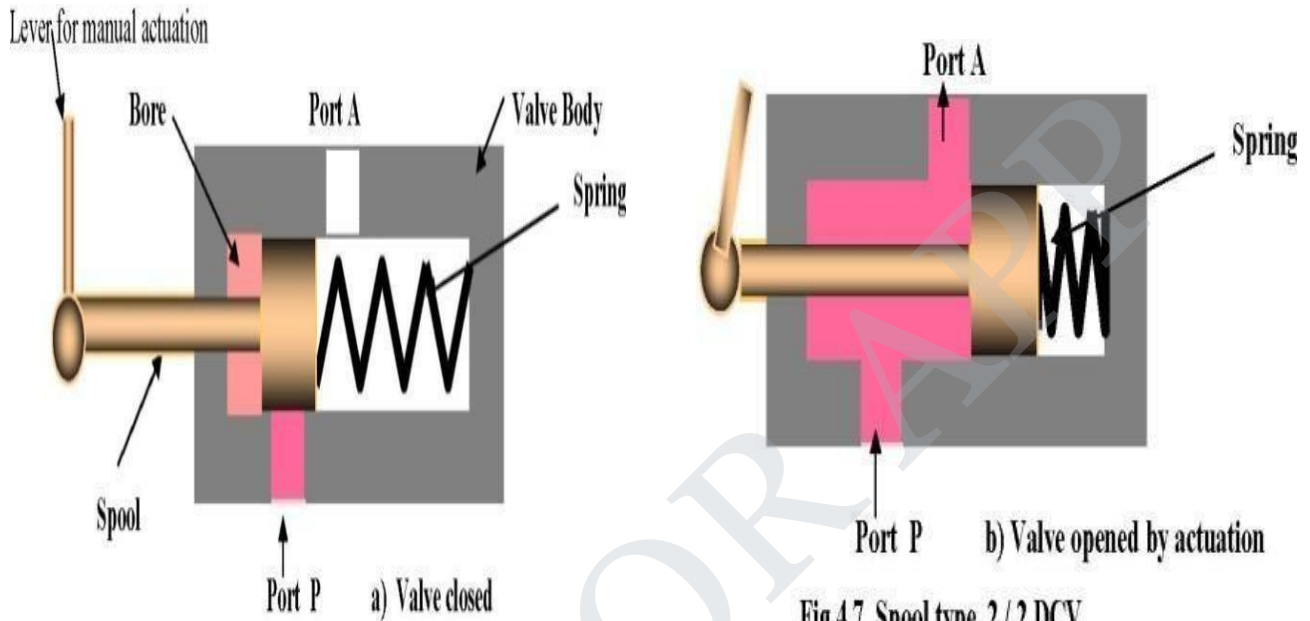
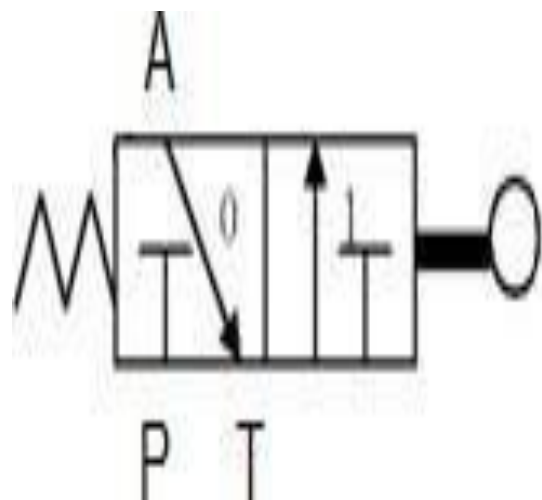
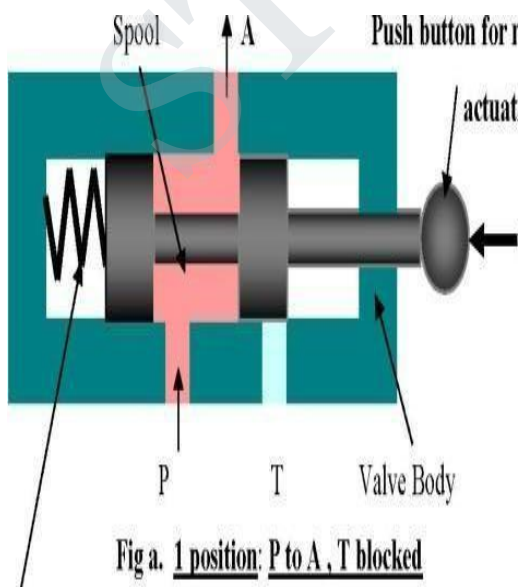

Fig 4.7 Spool type 2/2 DCV



3-position, 3-way valve:

Symbol of 2/3 valve Position 0: A to T

Position 1: P to A

Open center 3/4 DCV:

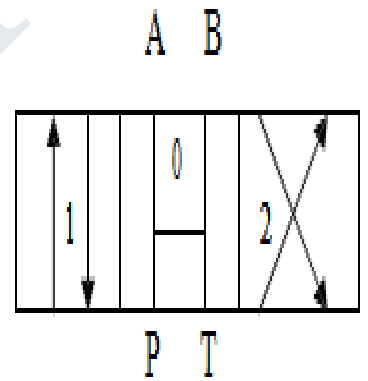
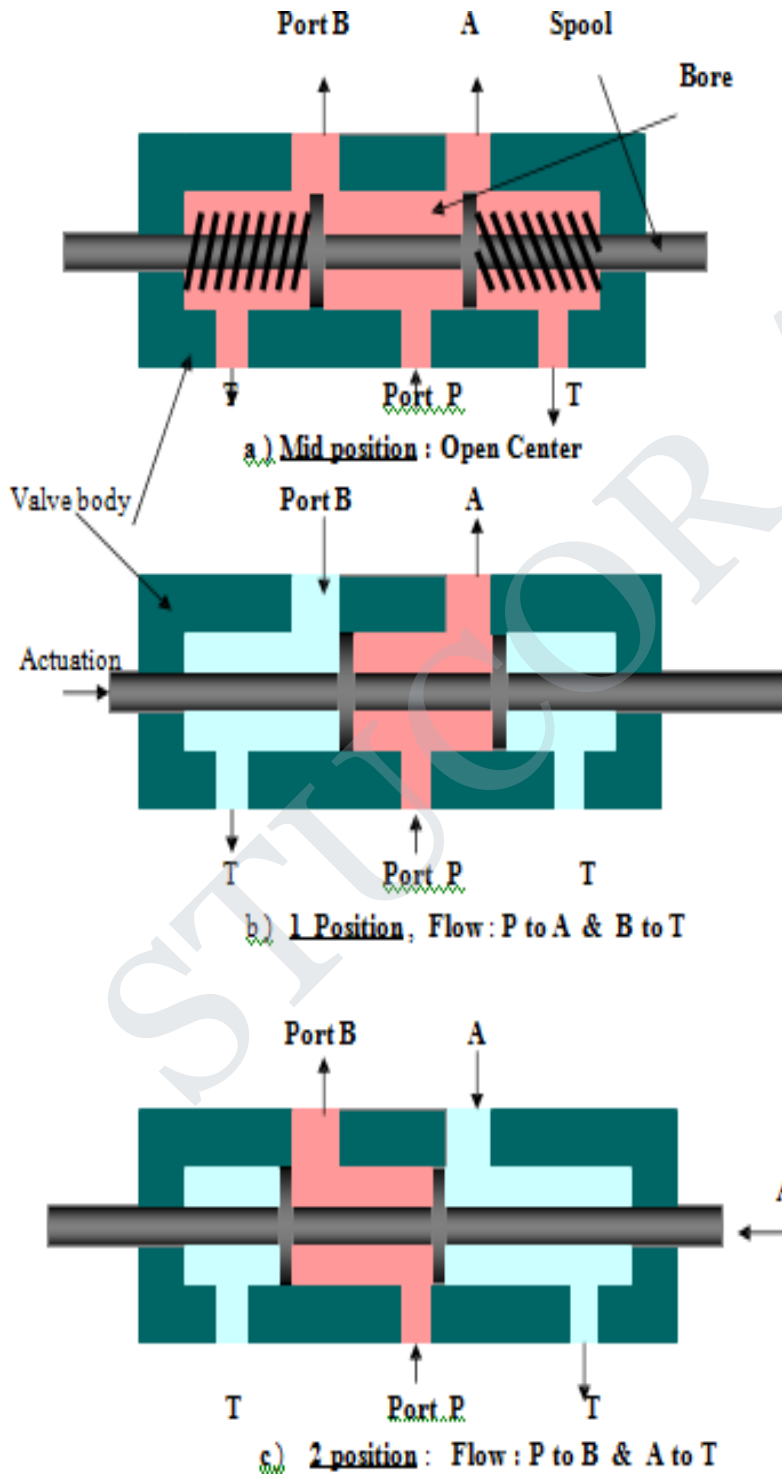

Symbol: Open Center 3/4 DCV

Closed Center 3 / 4 DCV:

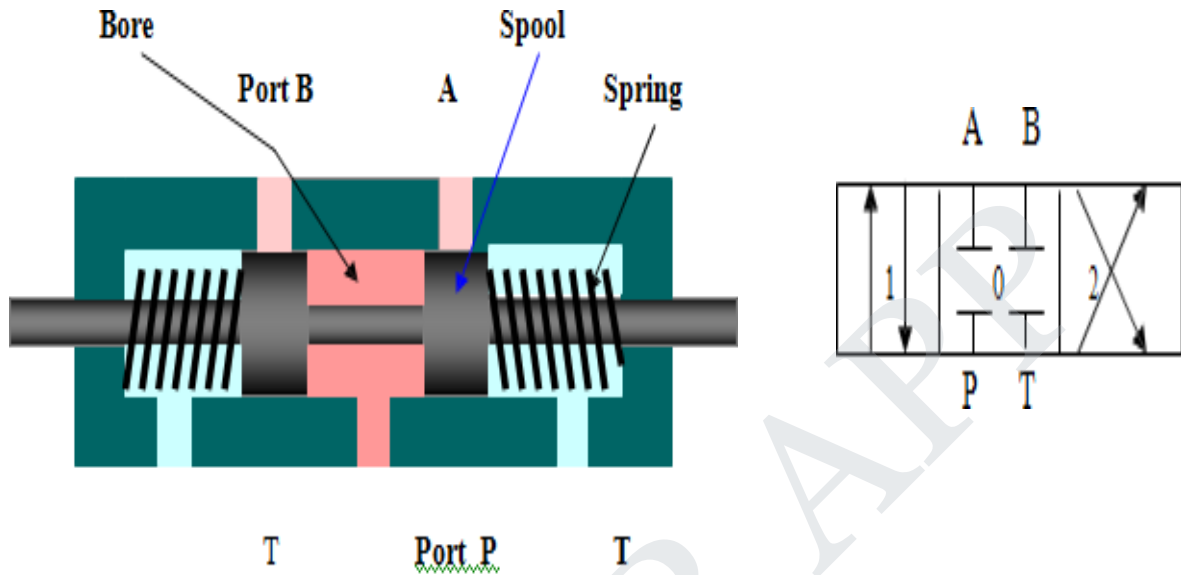

Mid Position: Closed Center 3 / 4 DCV

Tandem centered 3 / 4 DCV:

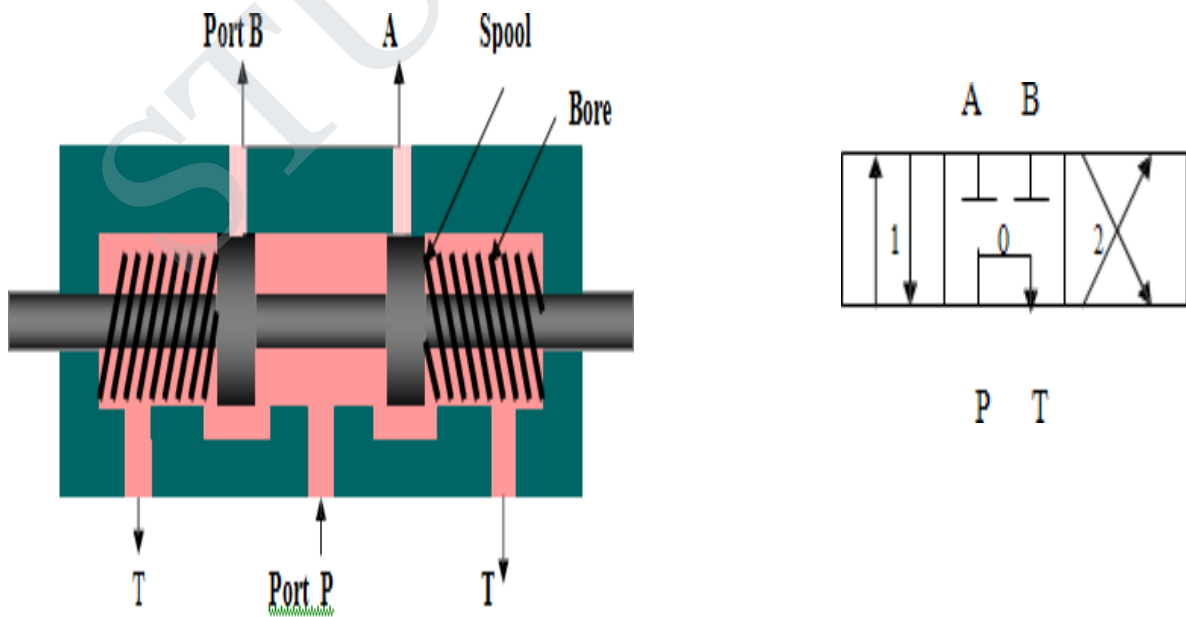

Tandem Center 3 / 4 DCV ; Mid position

Two position, Four – way DCV:

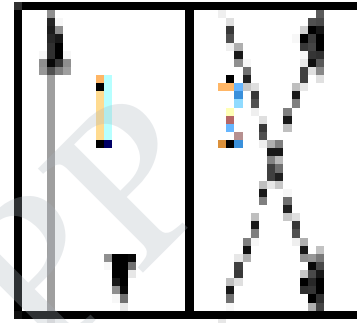
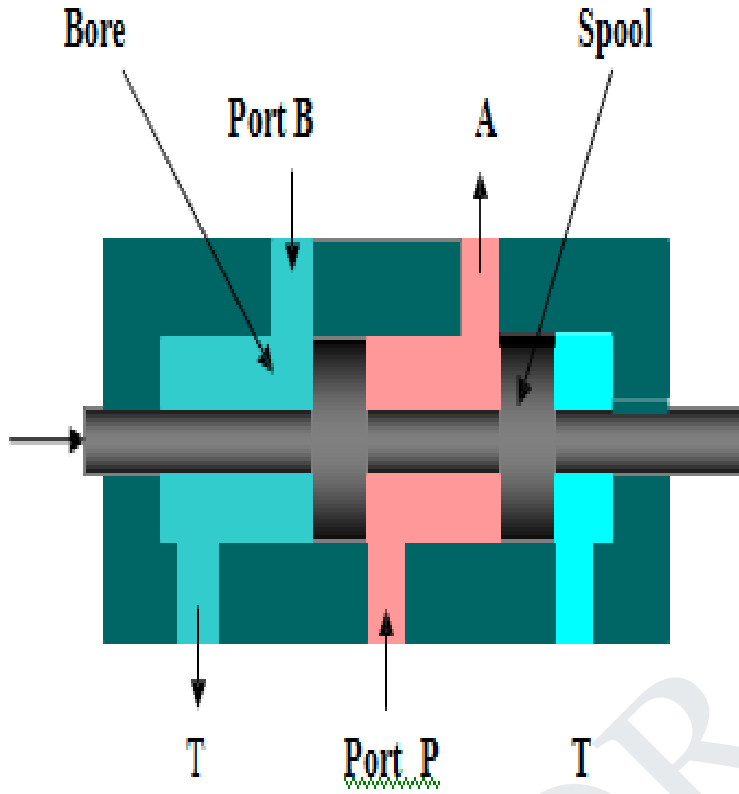

a. 1 Position : P to A and B to T

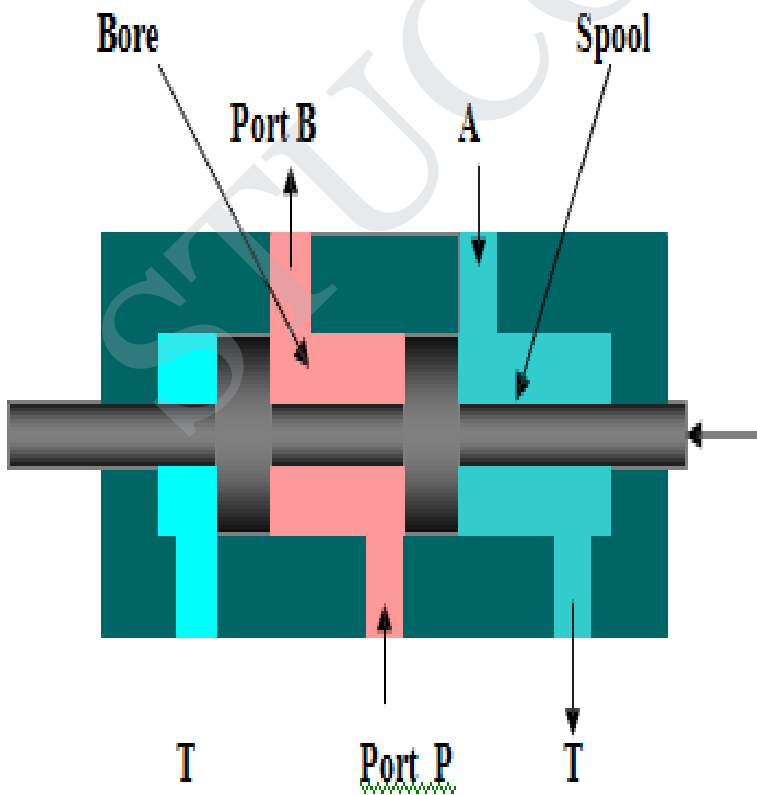

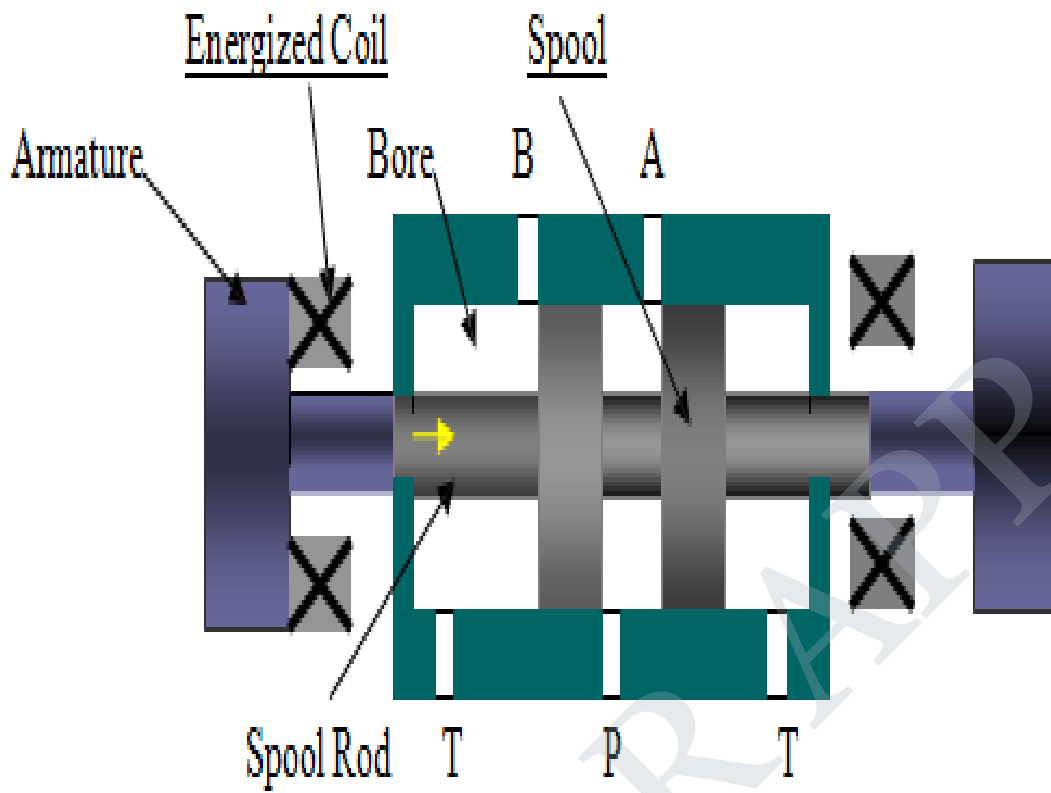

Working of solenoid to shift spool of valve.

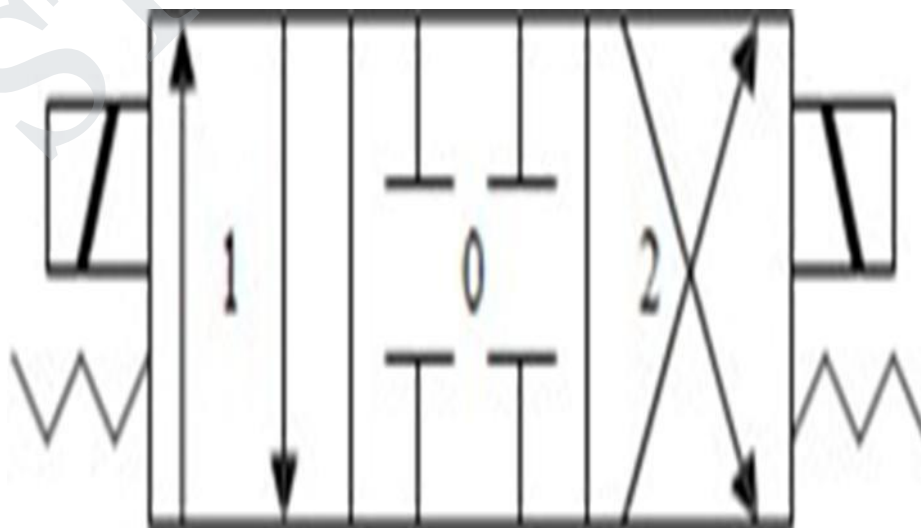

Solenoid Actuated DCV

Hydraulic actuation: This type actuation is usually known as pilot-actuated valve. The hydraulic pressure may be directly used on the end face of the spool. The pilot ports are located on the valve ends.

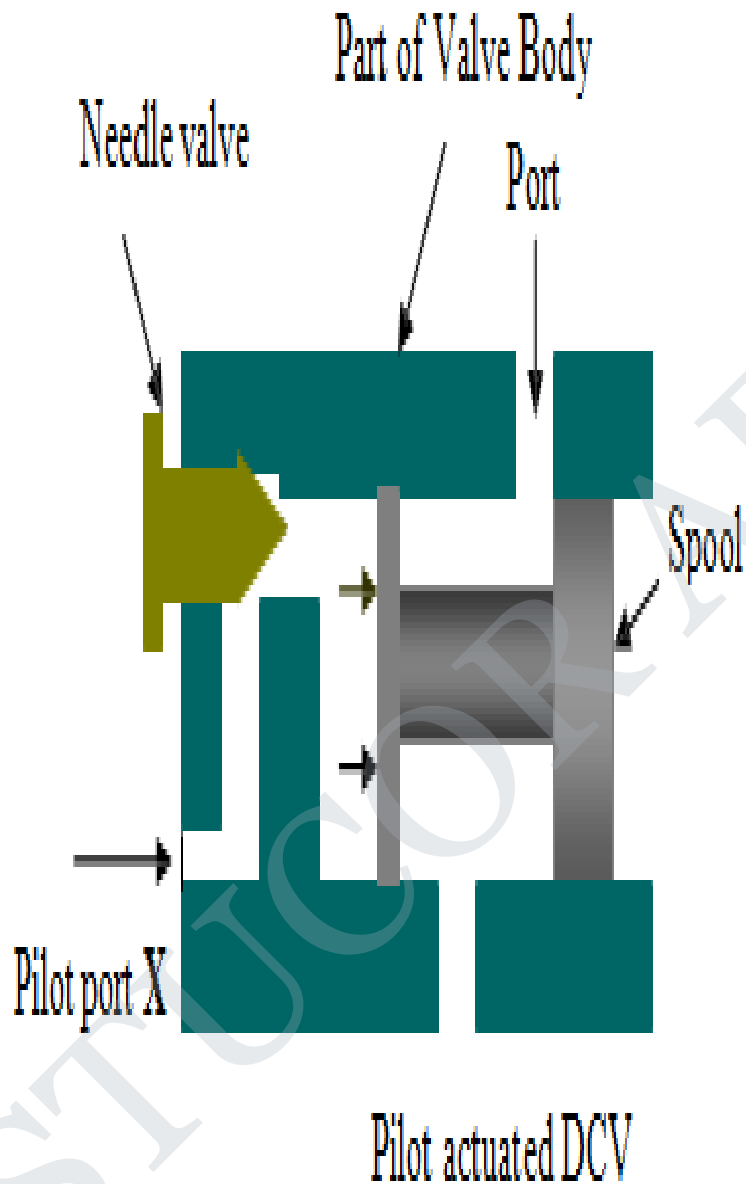

Hydraulic actuation

Figure shows a DCV where the rate of shifting the spool from one side to another can be controlled by a needle valve. Fluid entering the pilot pressure port on the X end flows through the check valve and operates against the piston. This forces the spool to move towards the opposite position. Fluid in the Y end (right end, not shown in the figure) is passed through the adjustable needle valve and exhausted back to tank. The amount of fluid bled through the needle valve controls how fast the valve will shift.

Indirect actuation of directional control valve:

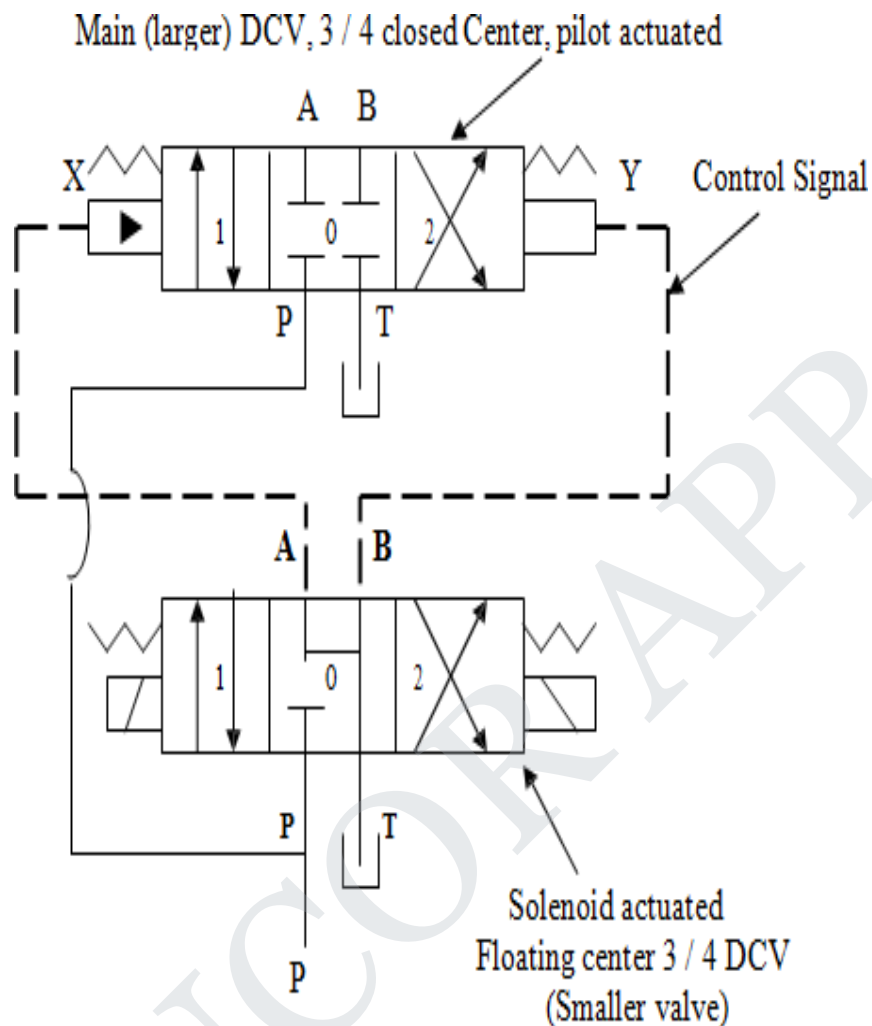

Pressure Relief Valves: The pressure relief valve is used to protect the hydraulic components from excessive pressure. It is one of the most important components of a hydraulic system and is essentially required for safe operation of the system. Its primary function is to limit the system pressure within a specified range. It is normally a closed type and it opens when the pressure exceeds a specified maximum value by diverting pump flow back to the tank. The simplest type valve contains a poppet held in a seat against the spring force as shown in the figure. The fluid enters from the opposite side of the poppet. When the system pressure exceeds the preset value, the poppet lifts and the fluid is escaped through the orifice to the storage tank directly.

It reduces the system pressure and as the pressure reduces to the set limit again the valve closes. This valve does not provide a flat cut-off pressure limit with flow rate because the spring must be deflected more

when the flow rate is higher. Various types of pressure control valves are discussed in the following sections. When the system pressure exceeds a set value, the poppet raises up and allows fluid.

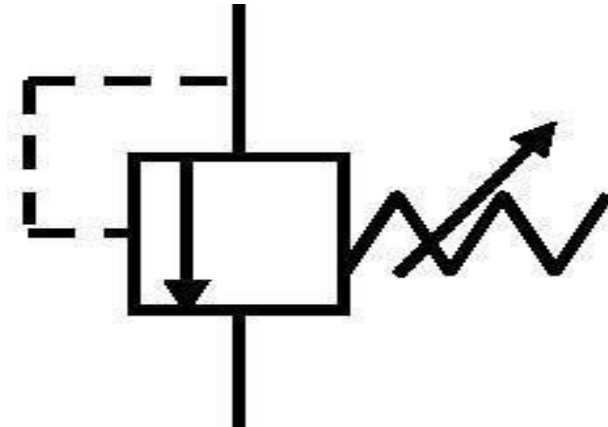

Pressure Relief Valve:

Unloading Valve:

An unloading valve is used to permit a pump to operate at minimum load. The unloading valve is normally closed with the spool closing the tank port. When a pilot pressure is enough to overcome the spring force, spool moves up and flow is diverted to tank. When the pilot pressure is relaxed, spool moves down and lets the flow to the circuit for operation.

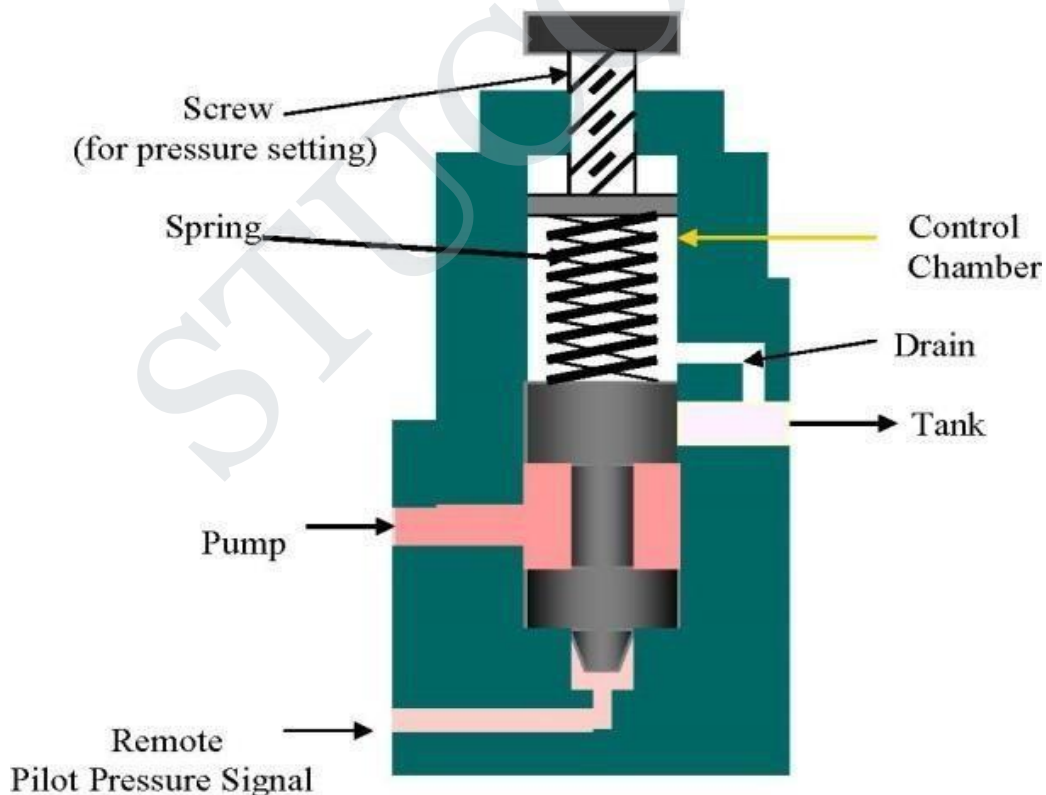

Unloading Valve

The unloading valve is used in system having one or more fixed delivery pump to control the amount of flow at any given time. A well designed hydraulic circuit uses the correct amount of fluid for each phase of a given cycle of machine operations. When pressure builds up during the feed phase of the cycle, the pilot pressure opens the unloading valve, causing the large discharge pump to bypass its flow back to the tank.

Sequence valve: A sequence valve's primary function is to divert flow in a predetermined sequence. It is a pressure-actuated valve similar in construction to a relief valve and normally a closed valve. When the main system pressure overcomes the spring setting, the valve spool moves up allowing flow from the secondary port.

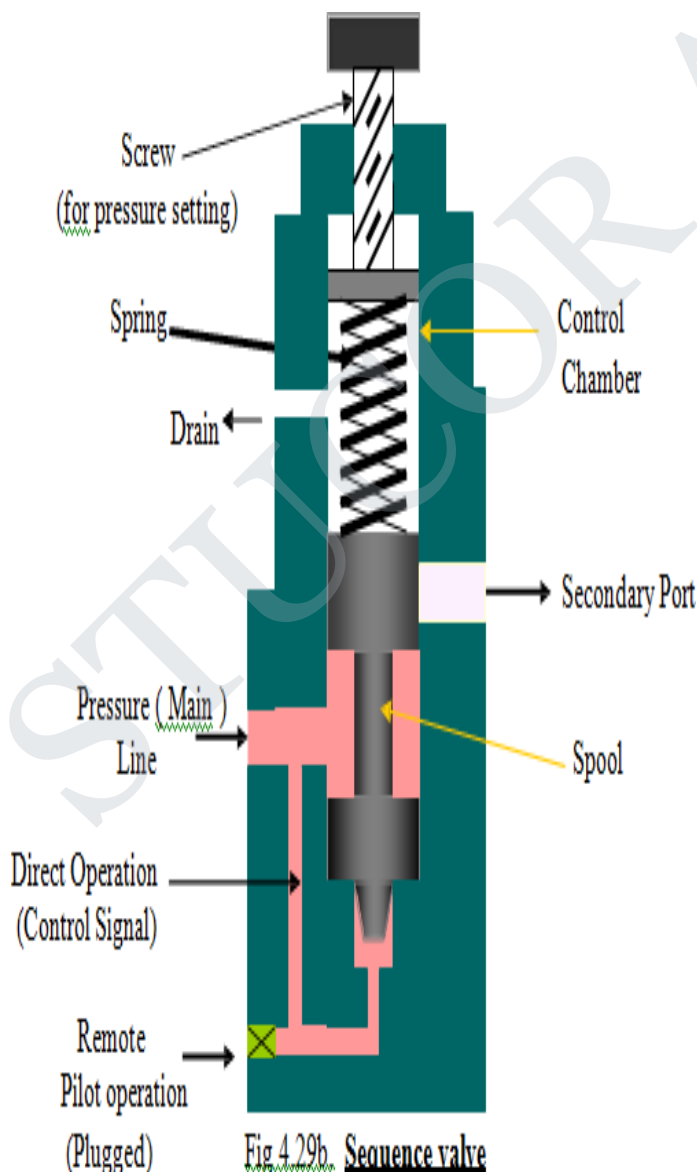
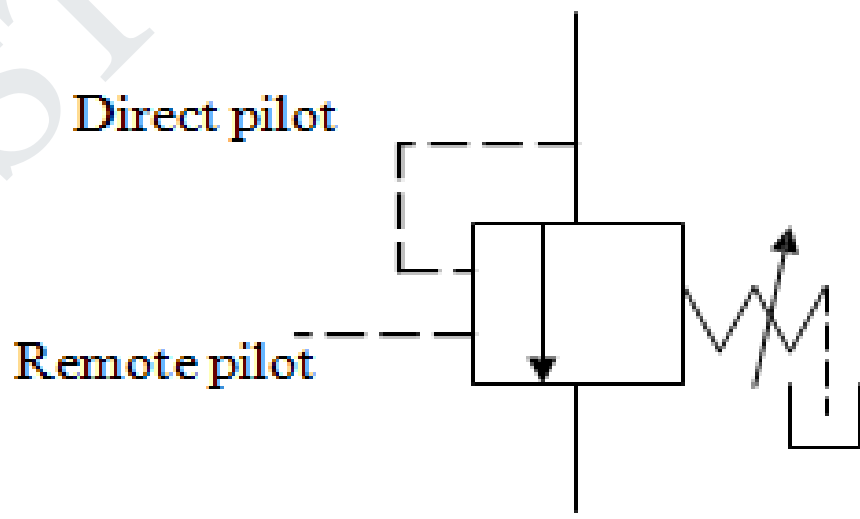
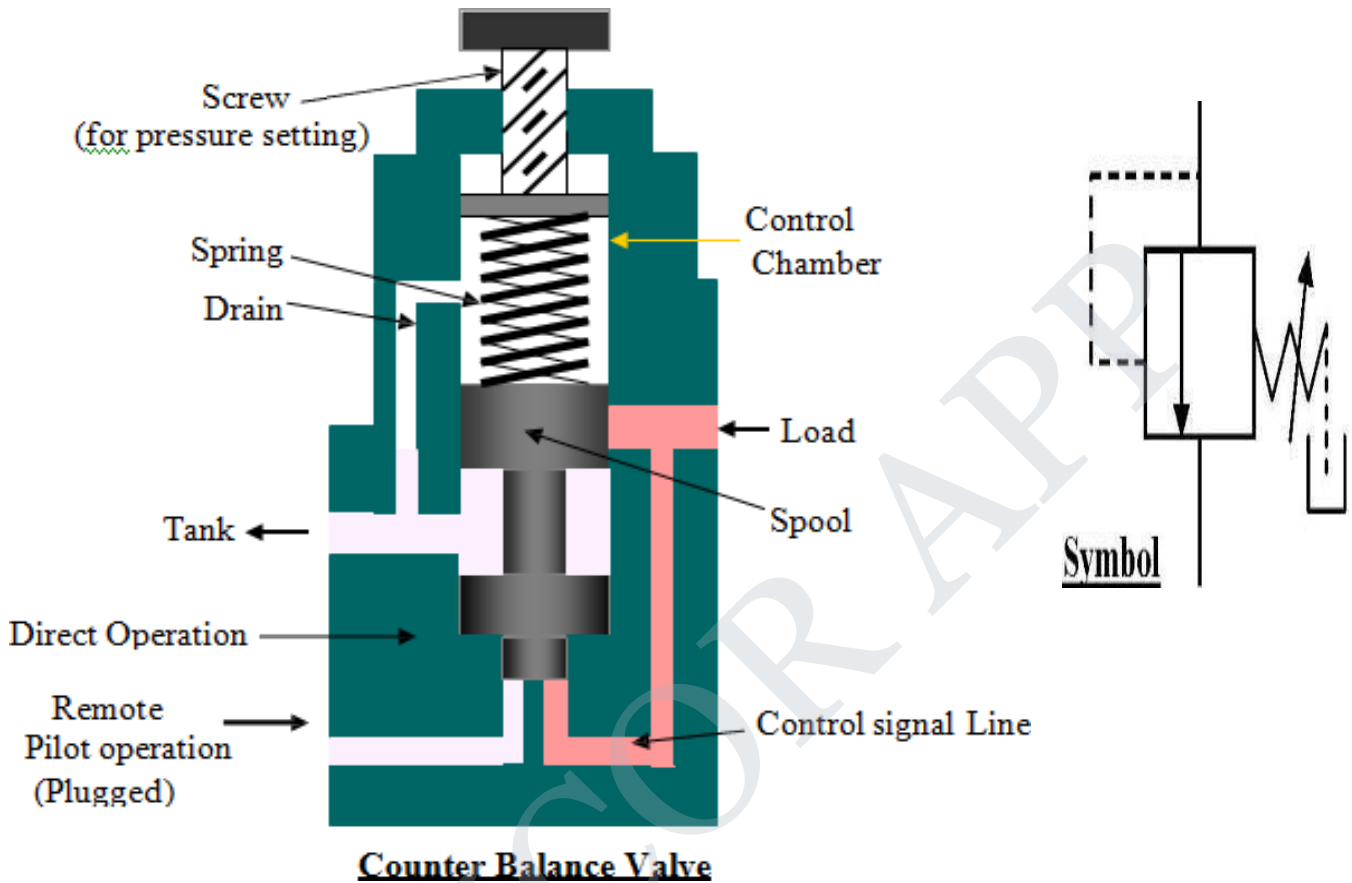
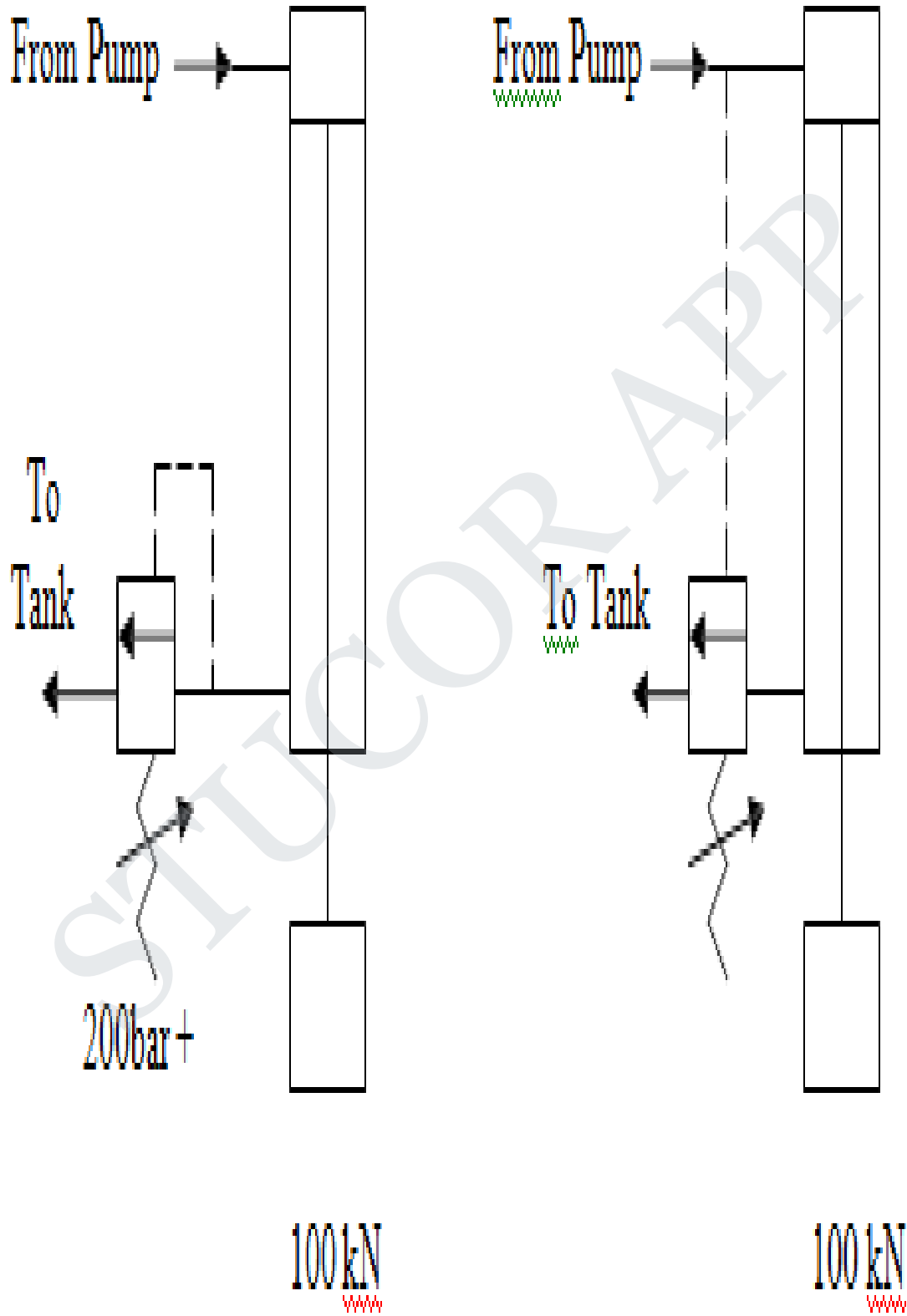

Fig 4 29h. Sequence valve

Counter balance Valve: A Counter balance valve is used to maintain back pressure to prevent a load from failing. One can find application in vertical presses, lift trucks, loaders and other machine tool that must position or hold suspended loads.



When a counterbalance valve is used on large vertical presses, it may important to analyze the source of pilot pressure. Figures illustrate the comparison between direct and remote pilot signal.



Pressure Reducing Valve: Pressure reducing valve is used to limit its outlet pressure. Reducing valves are used for the operation of branch circuits, where pressure may be less than the main system pressure.

The pressure reducing valve is normally an open type valve. When the secondary pressure is high, it lifts the spool against the spring force and throttles the flow till such extent that the secondary pressure reaches the value as set by spring.

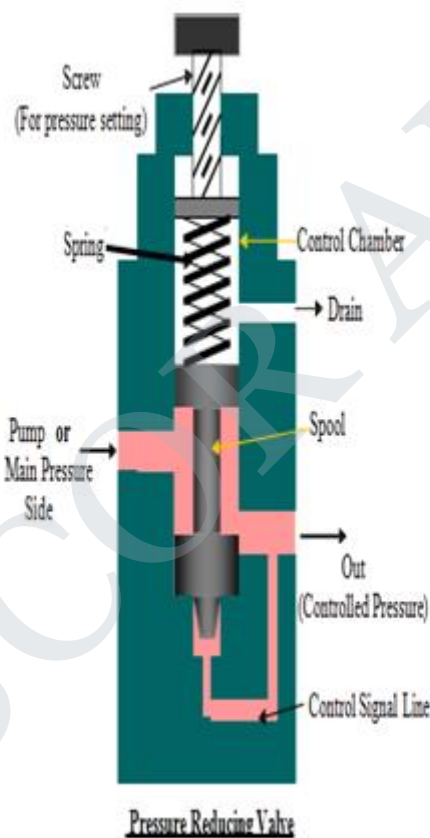

A hydraulic pump unit (HPUs) is an arrangement of interconnected components that control hydraulic energy. It is an integral component in most hydraulic systems.

- A hydraulic system is any component that uses a fluid to generate and transmit energy from one point to another within the enclosed system. This force can be in the form of linear motion, force or rotary motion. This is based on the Pascal's Laws: Therefore, whenever you refer to hydraulic power units, it is basically a system that generates pressure or force based on the above fundamental aspects. You can use them in applications that require heavy and systematic lifting.
- At times, the hydraulic pump units may also be referred to as the hydraulic power packs, hydraulic power pack units or hydraulic power units. They all refer to the same component. To generate,

transmit, distribute and control this energy, HPU uses different components.

- Reliability and safety
- Flexibility in design.

There are many types of hydraulic power packs in the market. As you will realize later in this hydraulic power pack eBook, the classification may depend on the construction, function and size of the power pack.

Let's begin with:

- Single acting hydraulic power pack
- Double acting hydraulic power pack

Single acting hydraulic cylinders:

In single acting hydraulic cylinders, the hydraulic fluid acts on only one end of the piston. Therefore, to push the piston back to its original position (retraction), the cylinder uses a compressed air, mechanical spring, a flying wheel or gravity load.

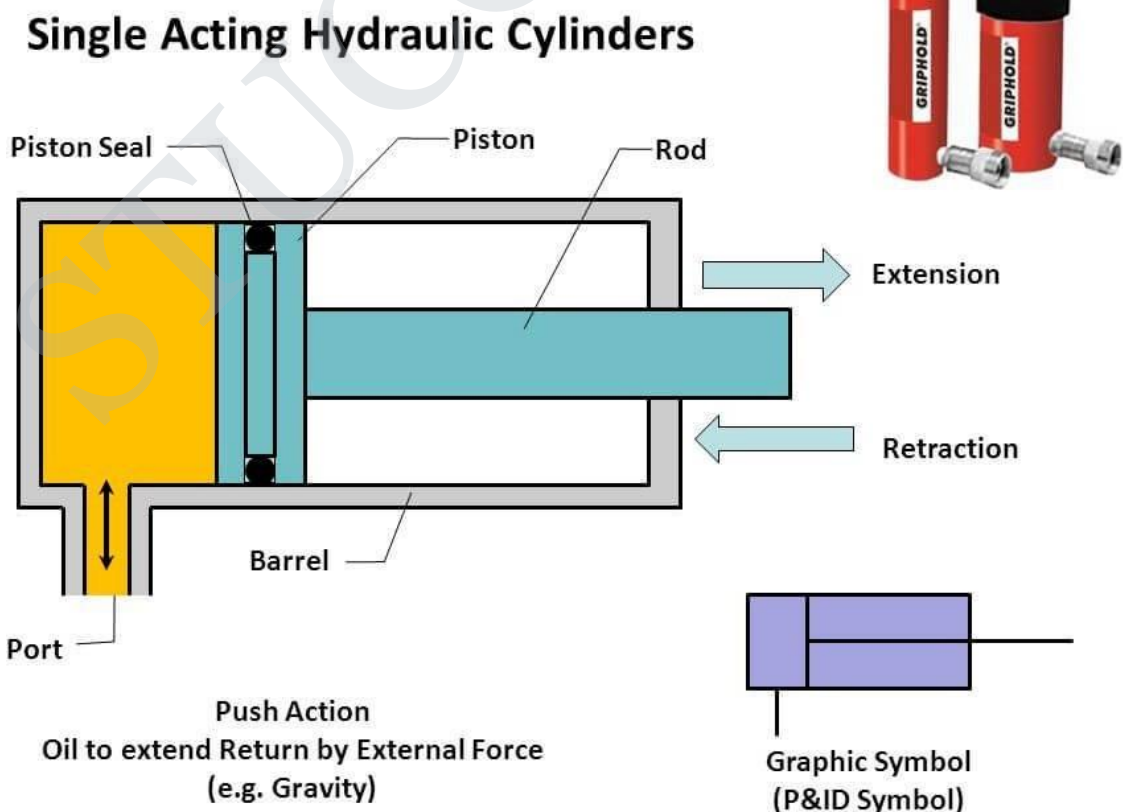

Single acting hydraulic cylinders

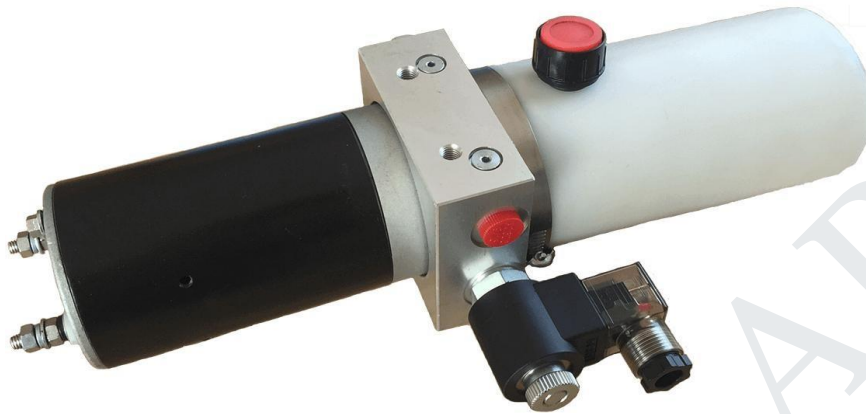

Micro Power Pack Units

They are compact in size and available as either single or double acting. Due to their flexibility, you can operate them in either single or double acting without necessarily having a solenoid control valve.

All you need to do is reverse the motor movement. Such micro power packs have dual pressure relief valves, giving separate control options. Also, a dual check valve reduces the effects of noise and induced pressure. Their tank capacity may range between 0.1 to 3 liters. To drive the hydraulic pumps, the micro hydraulic power pack uses either 150 to 800 watt DC motors. Remember, all these specifications may vary depending on the manufacturer.

2) Mini Power Pack Units:

The mini hydraulic power packs are suitable for mobility applications. They are slightly larger than the micro power pack units.

For these hydraulic power packs, space is never an issue.

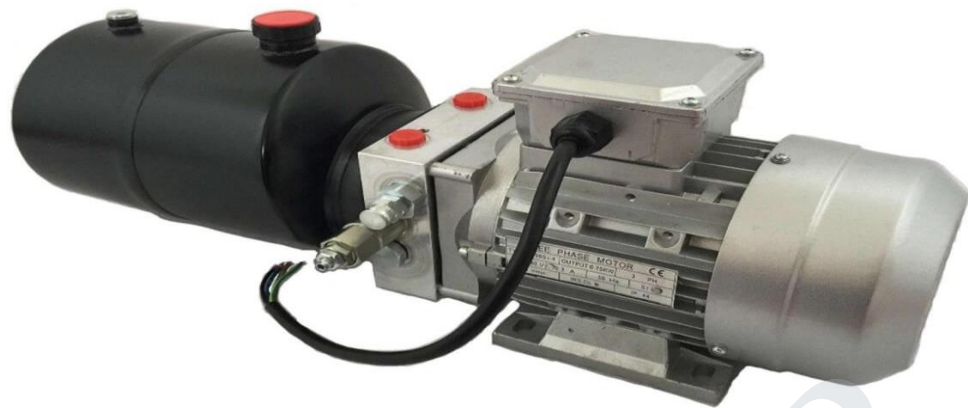

Mini Power Pack Units

They are available in different configurations such as horizontal or vertical mounting with a reservoir tank capacity ranging between 0.8 and 30liters. It uses a DC 0.8kW to 4.0kW motor, or AC 0.75kW to 7.5kW motor. The voltage of DC motors is DC 12V/24V or DC36v/48v, and the voltage of AC motors is AC 110V/220V/230V/380V/415V. With the advancement in technology, there are portable hydraulic power units that come with remote control options.

3) Standard Hydraulic Power Pack Units:

The standard hydraulic power pack units are designed for in-plant operations. They are mainly used for industrial applications. Such hydraulic power packs create huge power and high flow rates. They can handle heavy loads for a long period of time.



Their tank capacity is about 180 liters, with a flow rate of about 100 liters/minute. In most cases, you'll find that most standard hydraulic power packs have a motor rating of about 30kW.

4) Hydraulic Power Unit Stations:

The Hydraulic power unit stations are designed for specific applications. These may include sewage treatment, construction and mining applications, just to mention a few.



Hydraulic Power Unit Stations

Mostly, they are available in custom designs to meet the specific requirement of any unique application.

Broadly, these are the main types of hydraulic power packs available in the market. As you can see, as the sizes increase, their capacity and power also increases.

Function of Hydraulic Power Pack:

a single acting and double acting hydraulic power packs work. Generally, the main difference between the two is the force that moves the piston from one end of the cylinder to the other.

Single Acting Hydraulic Power Pack:

In a single acting hydraulic cylinder, the hydraulic fluid enters the cylinder only in one direction. As a result, it pushes the piston to the opposite side of the hydraulic cylinder.

Single Acting, Single ended Cylinder

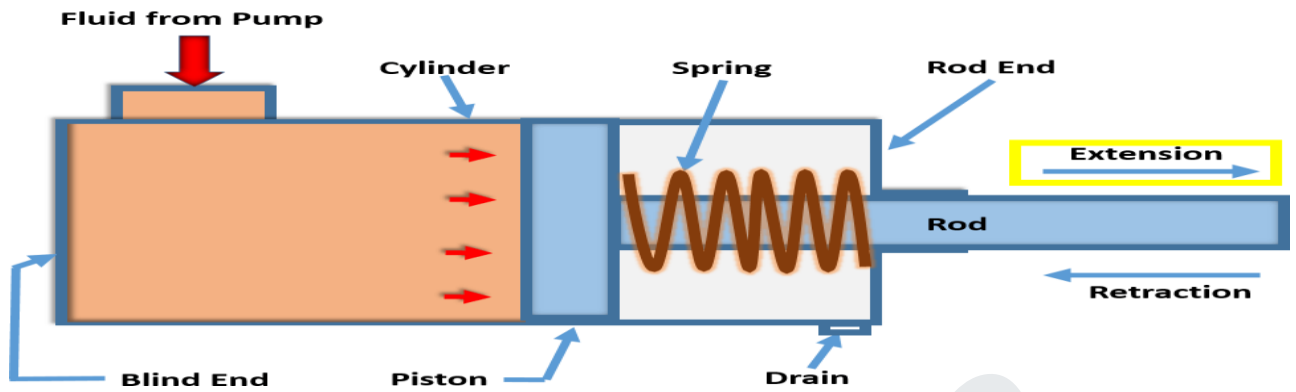

Single Acting Hydraulic Power Pack

To return the piston to its original position, there must be an external intervention, i.e., a force that will push the piston to its initial position. This force can be in the form of spring tension, gravity or compressed air.

So, assuming your single acting cylinder has a spring on one side, then you should expect; When the hydraulic fluid enters the cylinder, it will exert pressure on the piston head, pushing it in the opposite direction. As a result, the spring will be compressed between the opposite side of the piston and the cylinder.

During the retraction process, the cylinder weight holding valve (solenoid release valve) is opened, releasing pressure due to the hydraulic fluid. As a result, the spring tension (due to the compression) will force the piston back to its original position, pushing the hydraulic fluid back to the reservoir.

Single Acting, Single ended Cylinder

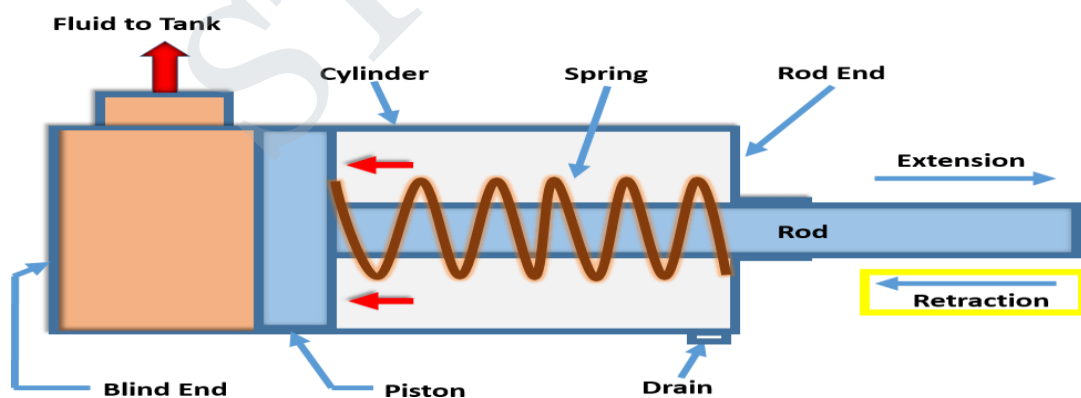

Single Acting Hydraulic Power Pack

Normally, you will find that this single acting hydraulic actuator system is fitted with only one hydraulic hose

They are common in applications where either weight, gravity or other external force is available to push the cylinder in the direction opposite to that of the hydraulic fluid.

Therefore, it is only a single acting power unit that can operate these systems. The single acting power packs are a perfect choice for dump trailers, tipper applications, hydraulic lifts, etc.



Single Acting Hydraulic Power Pack

A single acting hydraulic power pack can, thus, achieve the —power up, gravity downl required to operate any single acting cylinder.

These accessories are popular since they can be mounted in any direction, besides being cheap compared to the double acting cylinders.

Double Acting Hydraulic Power Pack:

These are systems where the hydraulic fluids act interchangeably on both ends of the piston.

Double Acting, Single ended Cylinder

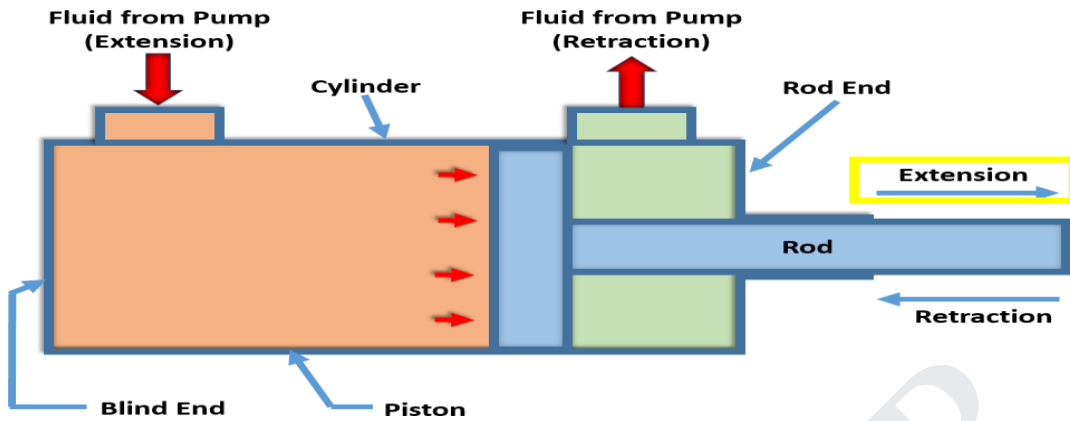

Double Acting Hydraulic Power Pack

Unlike the single acting hydraulic cylinders, that achieve —power up, gravity down, a double acting hydraulic cylinder achieves a -power up, power downl.

These systems are designed with two hydraulic fluid hose pipes, taking fluid into and out of the extreme ends of the hydraulic cylinder.

Double Acting, Single ended Cylinder

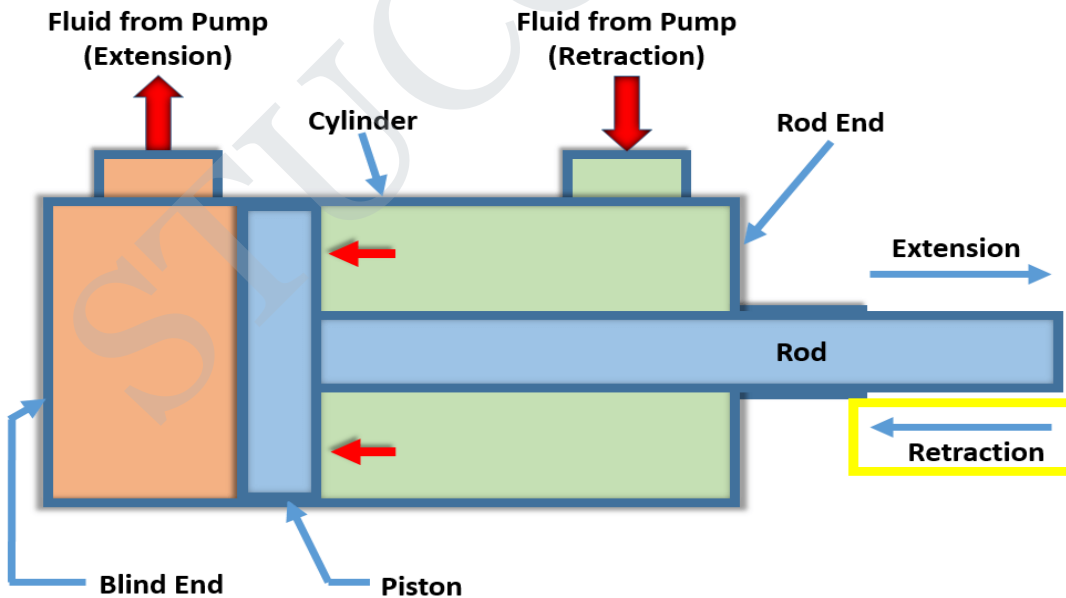

Double Acting Hydraulic Power Pack

In some applications such as snow-plows and hydraulic presses, double acting hydraulic systems are a perfect choice due to the following reasons. The existence of enough force to return the piston to its original position.

The pressure hydraulic fluid will automatically do this for you. Secondly, they have a small hydraulic reservoir.

Therefore, they are a perfect choice where the space available is limited.

Thirdly, corrosion is reduced since the rod is lubricated by the fluid that flows in both ends of the hydraulic cylinder. This reduces the possibility of wear and tear.

Apart from these, the double acting cylinders are readily available. So, even getting the spare parts is easier compared to the single acting. Therefore, such a hydraulic system, your only option is to choose a double acting hydraulic power pack. They are the only accessories that can drive a double acting cylinder system.



Double Acting Hydraulic Power Pack

Depending on the specifications of your systems, you can choose from a wide range of double acting hydraulic power units with the right specifications.

Other than the double acting power units and single acting power units, there are certain complex applications that may require advanced systems.

Application of Hydraulic Power Pack:

- Lifting heavy motors, Hay or offloading trucks.
- Hydraulic systems provide a perfect solution to this problem.
- The transportation, lifting and distributing heavy equipment with the help of a hydraulic system.

Hydraulic technology in very many industries such as agriculture, automotive, manufacturing industries, garbage collection, mobile hydraulics, etc.

- Plastic tube thermal melting welders
- Steering gears
- Transmission systems
- Hydraulic motor
- Hydraulic wrench
- Hydraulic road blocker

Hydraulic Power Unit Design and Operation:

A hydraulic system employs enclosed fluid to transfer energy from one source to another, and subsequently
tion, or force.



Hydraulic Power Unit

Hydraulic power units apply the pressure that drives motors, cylinders, and other complementary parts of a hydraulic system. Unlike standard pumps, these power units use multi-stage pressurization networks to move fluid, and they often incorporate temperature control devices. The mechanical characteristics and specifications of a hydraulic power unit dictate the type of projects for which it can be effective.

Some of the important factors that influence a hydraulic power unit’s performance are pressure limits.

UNIT-III HYDRAULIC CIRCUITS AND SYSTEMS

SOME TYPICAL HYDRAULIC CIRCUITS:

In this part we will look at some of the simple and commonly encountered hydraulic circuits. The circuits are drawn using the standard graphical symbols.

Control of a Single- Acting Hydraulic Cylinder:

In single acting cylinder hydraulic force is exerted on the piston for forward movement (to right in the figure shown). For retraction, no hydraulic force is applied and the rod moves (to left) due to a spring force or weight of the piston and rod

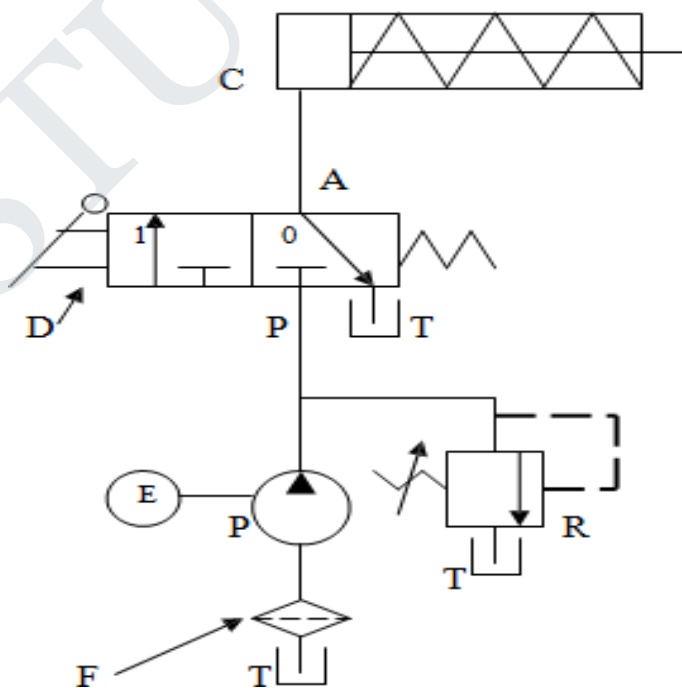

Figure shows a two-position, three way, manually operated, spring offset directional control valve (DCV) used to control the operation of a single – acting cylinder.

Single- Acting Hydraulic Cylinder

As valve is moved to occupy position 1 (left) flow goes to rod end and rod is pushed to right.

When valve is moved to position 0, i.e. shifted to right indicate position, flow from pump is blocked in the valve. There is no hydraulic pressure on the piston side. The flow goes to tank via relief valve at the set pressure. The actuator moves to left due to spring force acting on the rod end of piston.

Control of Double Acting Hydraulic Cylinder:

Double –Acting cylinders can be extended and retracted hydraulically. Thus, an output force can be applied in two directions.

Double acting cylinder:

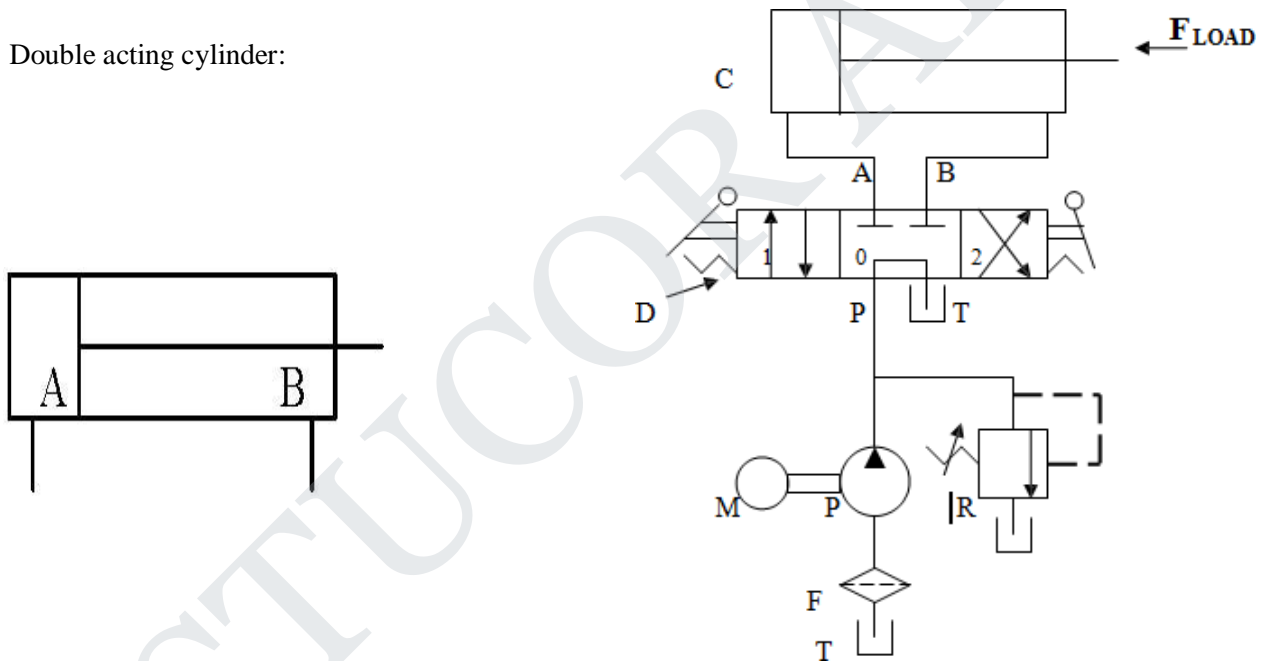

Double Acting Hydraulic Cylinder

The valve is manual 3 position /4-way valve. In the neutral or valve central (0) position, oil from pump goes to tank, and no action on actuator. Note that the valve does not go through relief valve to tank, thereby saving power (Pressure set in relief valve x pump flow rate). There is minor power loss due to drop in valve orifices, and piping.

In position 1 of valve, oil flow is P to A. ie. from pump to piston side and rod moves to right acting on the load. Oil from rod side chamber of cylinder goes to tank (B to T).

In position 2, Oil from pump goes to rod end (P to B) and Oil from piston end goes to tank. (A to T) thereby pushing the rod (load) to left.

Regenerative circuit:

Operation: Figure shows a regenerative circuit that is used to speed up the extending speed of a double-acting hydraulic cylinder.

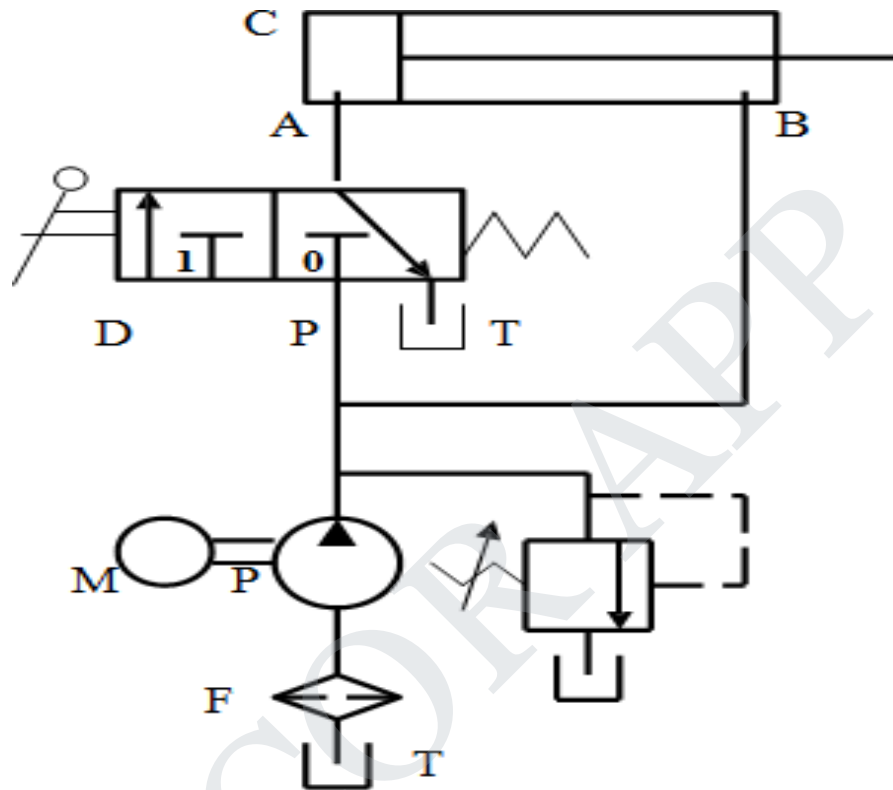

Regenerative circuit

It can be seen that in position 1 when pump is connected to piston side chamber ,ie., when main load is operated, fluid from piston side also flows into it. Thereby the flow rate is more than pump flow. Thus the velocity of actuation on piston side is increased by the ratio (A_p / A_r), where A_p is the piston area and A_r is the rod area. .However, the net force due to the piston rod is reduced to $A_r \times \text{Pressure}$.

In position 2, when flow is directed to rod side, oil from the piston side flows to tank directly.

Pump Unloading Circuit:

The figure shows a circuit using an unloading valve to unload a pump. The unloading valve opens when the cylinder reaches the end of its extension stroke because the check valve keeps high-pressure oil in the pilot line of the unloading valve. When the DCV is shifted to retract the cylinder, the motion of the piston reduces the pressure in the pilot line of the unloading valve. This resets the unloading valve until the cylinder is fully retracted, at which point the unloading valve unloads the pump. Thus, the unloading valve unloads the pump at the ends of the extending and retraction strokes as well as in the spring-centered

position of the DCV.

Counter Balance Valve

Pump Unloading Circuit Counter Balance Valve Application:

Counter balance valve is used to hold loads in vertical position without descending while idling in neutral position. Rod side fluid cannot flow unless a pilot pressure acts on the valve and permits flow to tank.

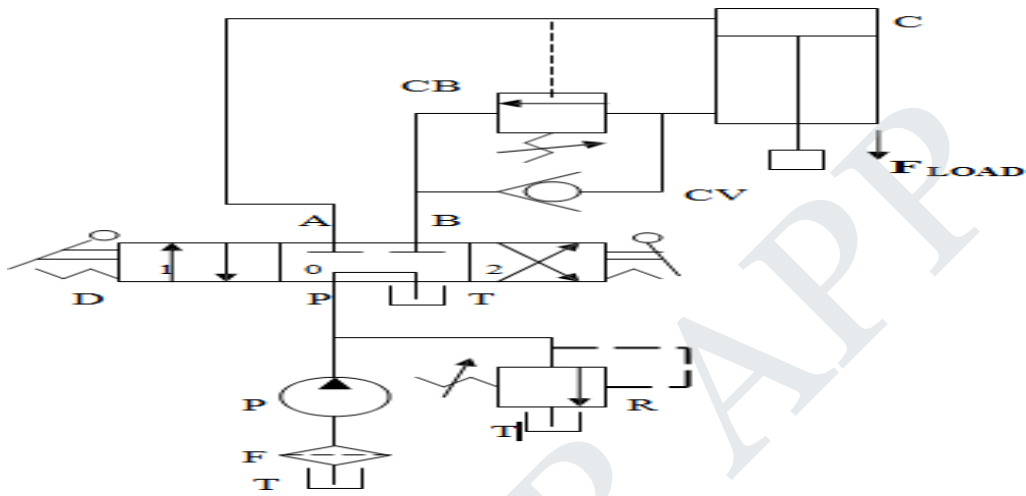

STUCOR APP

Hydraulic Cylinder Sequencing Circuits:

Figure shows an example where two sequence valves are used to control the sequence of operations of two double-acting cylinders C1 and C2 . When the DCV is shifted into its left position, the left cylinder extends completely, and pressure builds up and only when the left cylinder pressure reaches the pressure setting of sequence valve, the sequence valve connected to the right cylinder opens and permits flow to rod end of C2, and extends it.

If the DCV is then shifted to right position, flow to rod end of C1 is blocked, but flows freely to rod end of C2. After C2 retracts fully, pressure builds up till the valve connected to C1 opens.

Thus the sequence is C1Ext - C2Ext - C2Retr – C1.

One can find the application of this circuit in press circuit. For example, the left cylinder the clamping cylinder C1 could extend and clamp a work piece. Then the right cylinder C2, the punching cylinder extends to punch a hole in the work piece. The right cylinder then retracts the punch , and then the left cylinder retracts to declamp the work piece for removal.

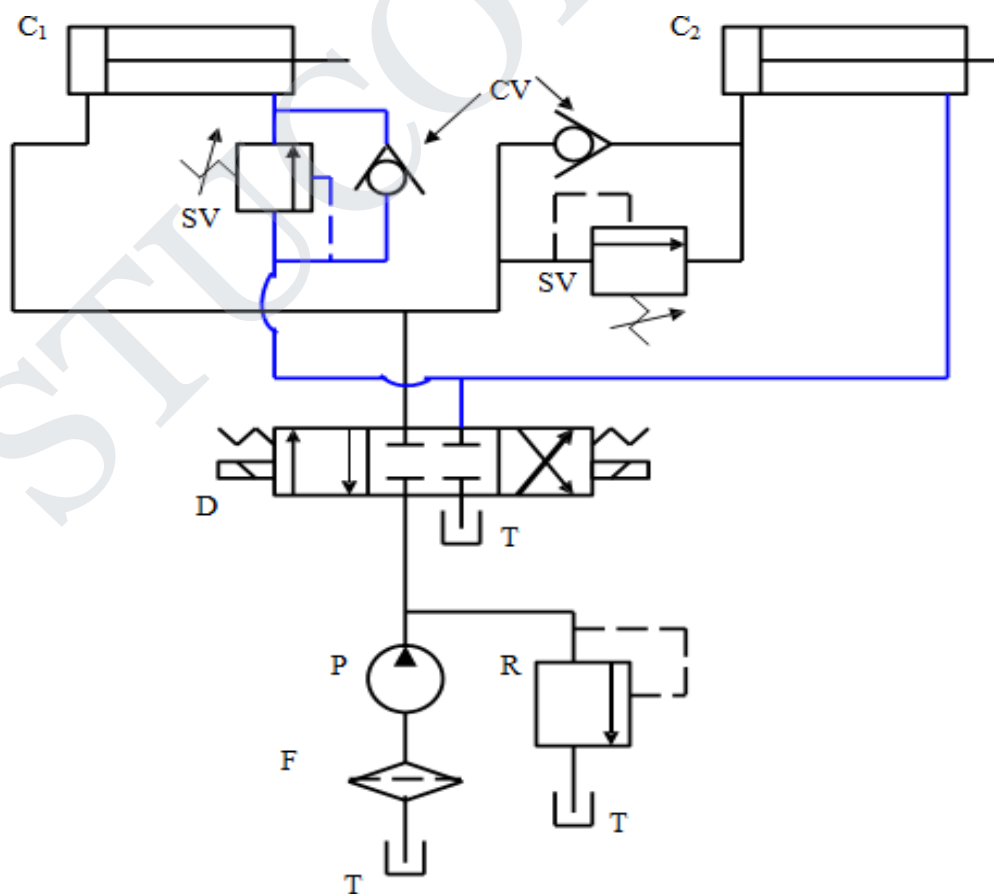

Cylinder Sequencing circuit

Automatic Cylinder Reciprocating System:

Using Sequence Valves Operation: In the left position of valve shown, P is connected to rod-side, and the rod retracts. After piston reaches the left end, pressure builds up on rod side which opens the sequence valve on the right and permits pilot hydraulic line to act on the main DCV to switch to right position. Check valves allow pilot oil to leave either end of the DCV while pilot pressure is applied to the opposite end.

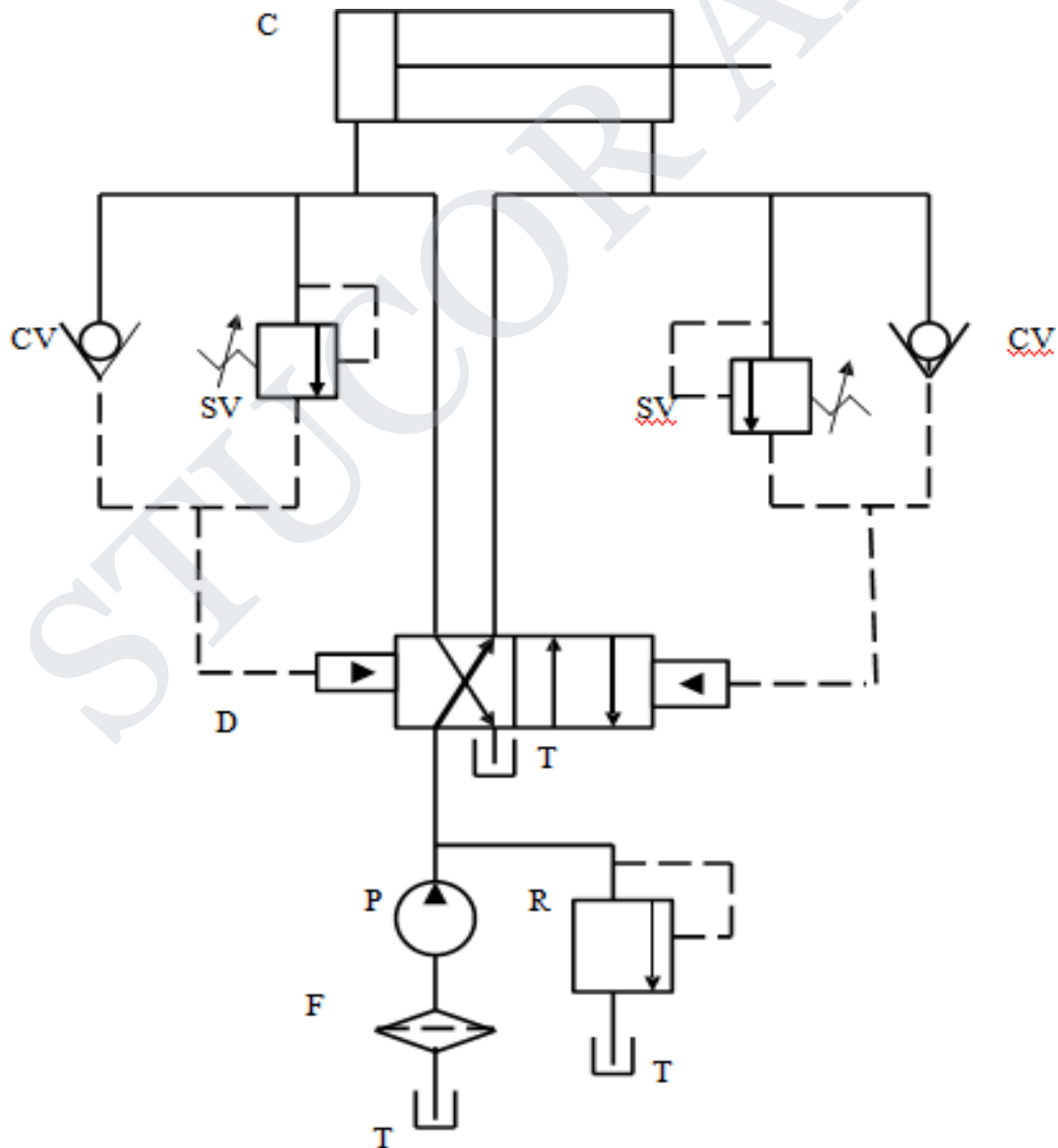

Automatic Cylinder Reciprocating System using Sequence valves

An alternative circuit is shown using limit switches and solenoid valve, and a pilot operated DCV. .

Operation: Suppose the left position of the main DCV is on. Then the piston rod moves to right > It hits the limit switch 2 > which energises solenoid valve D2 > which shifts the solenoid operated DCV (D2) to position (top as shown) > which now permits pilot oil from D2 to right end of DCV D1 > changes D1 position 2 > flow is now to rod end > rod moves to left till it hits limit switch 1.

Now the reverse of the above sequence is repeated so that Position 1 of the main DCV becomes operative. Thus it leads to automatic reciprocation of the actuator between the limit switch positions. Circuits are shown for synchronizing the operation of two cylinders (i.e., simultaneous equal movement).

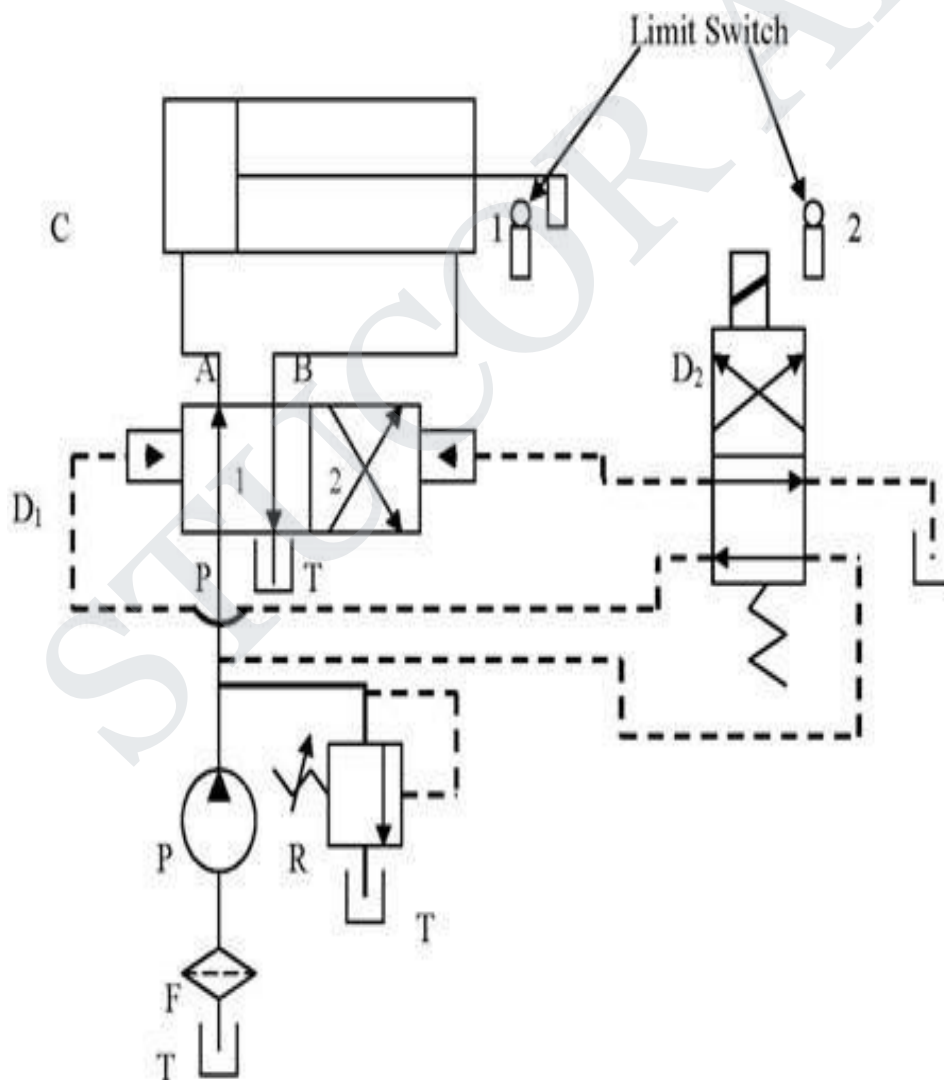

Automatic Cylinder Reciprocating System using DCV's.

Cylinder connected in Parallel:

In the circuit shown, piston or rod ends of both cylinders are connected to one line. Thus oil flows simultaneously. However, if load on one cylinder is more, the other cylinder needing less pressure operates first, and after completion of stroke, pressure builds up to operate the second cylinder. This operation is not synchronized. The problem may arise with slight differences in the size of cylinders as well.

Cylinders connected in Series: The rod end of C1 is connected to piston end of C2. Thus C1 and C2 have to move together. However, for to have equal stroke, rod end area of C1 should be equal to piston area of C2. Also, rod end of C2 has to have high pressure to do work by C2. Hence piston side pressure would be that much higher.

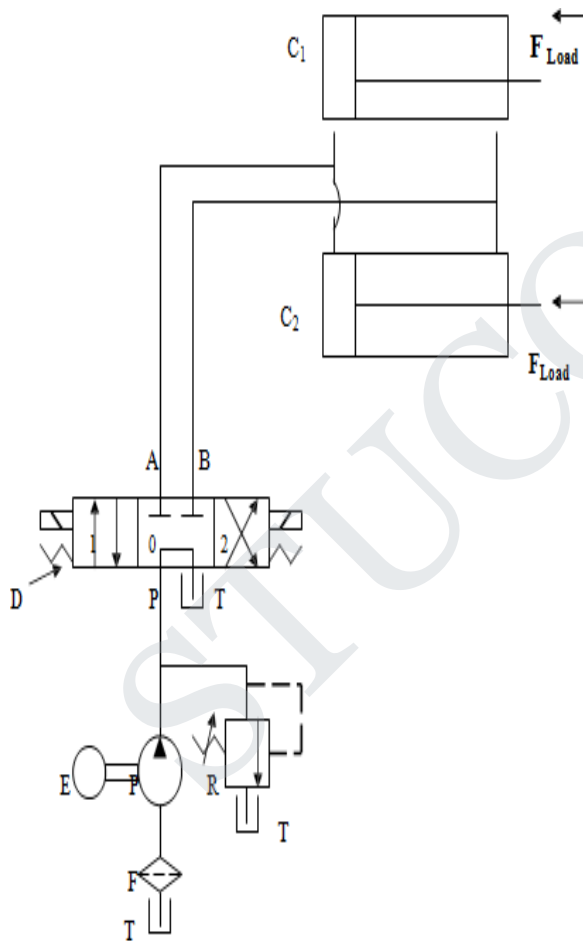

Cylinder hooked in parallel for synchronizing
(will not operate)

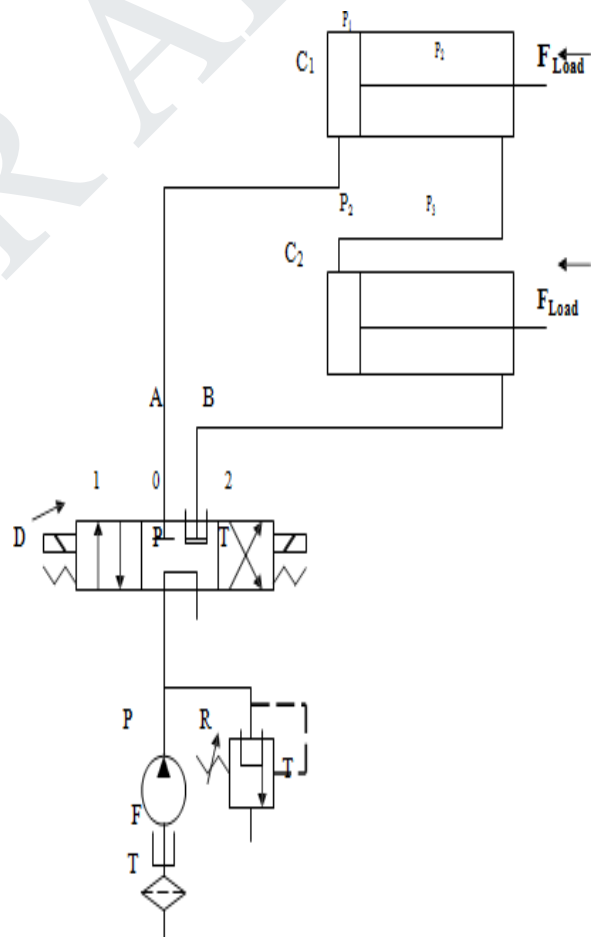

Cylinder hooked in Series for synchronizing
(Will Operate)

Cylinder connected in Parallel

Speed Control:

Speed control of Hydraulic Cylinder: Speed control of a hydraulic cylinder is accomplished using a flow control valve. A flow control valve regulates the speed of the cylinder by controlling the flow rate to and of the actuator.

There are 3 types of speed control:

- Meter-in circuit (Primary control)
- Meter-out circuit (Secondary control)
- Bleed -off circuit (By pass control)

Meter – in Circuit: In this type of speed control, the flow control valve is placed between the pump and the actuator. Thereby, it controls the amount of fluid going into the actuator. Figure below shows meter-in circuit. When the direction is reversed, oil from piston side flows to tank via check valve as well as FC valve freely. The excess flow is dumped to tank via relief valve.

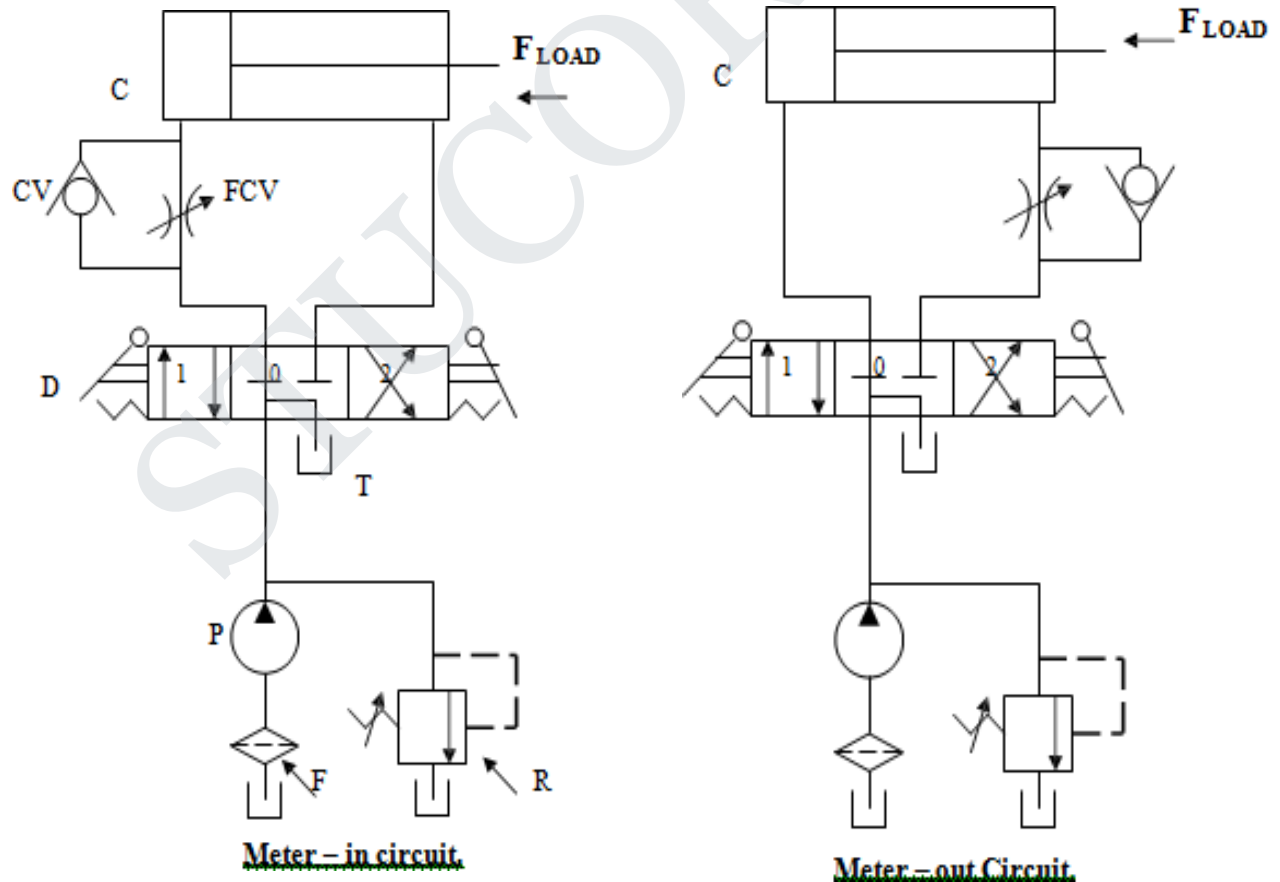

Meter – in Circuit

Meter – out Circuit: In this type of speed control, the flow control valve is placed between the actuator and the tank. Thereby it controls the amount of fluid going out of the actuator and thereby the speed of retraction. Meter out circuits are useful to control free fall of loads due to gravity etc. connected to the load. Oil is dumped at load pressure but not at relief valve set pressure. However, meter –out can lead to high pressure intensification sometimes twice supply pressure, leading to damage of seals etc. Still it is favored in drilling, reaming and milling when it is required to control the tool feed rate.

Bleed off circuit: This circuit is used to overcome the disadvantages of meter-in and meter- out circuits. Here, a flow control valve is kept between either ends. Flow is controlled in each direction, and excess flow to tank is not through relief valve.

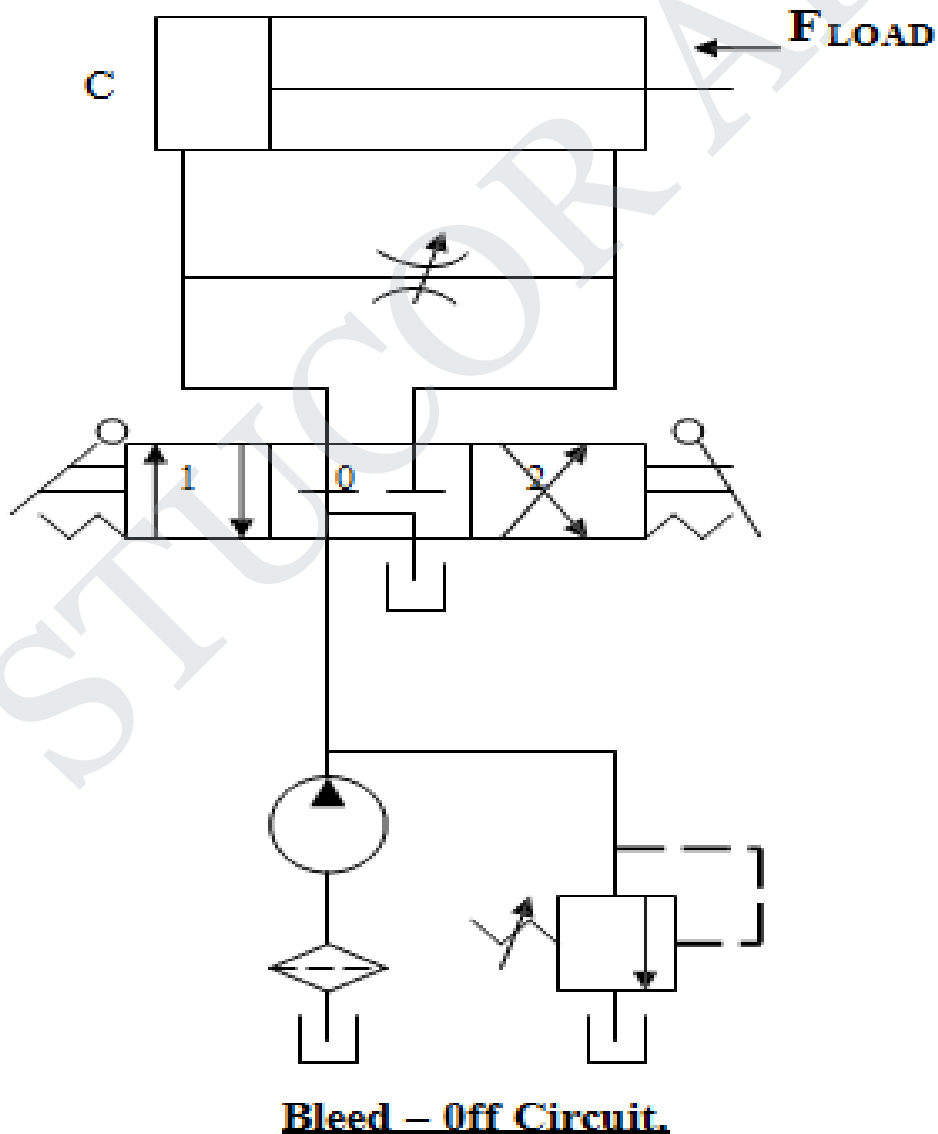

Hydraulic Servo Systems:

Servo systems refer to systems where automatic control of actuator movements is required. These movements should be as per a predetermined rate and deviations should be reduced to a minimum.

A servomechanism is an automatic control system designed to operate in accordance with input control parameters. The mechanism continuously compares the input signal to the feedback signal to adjust the operating conditions to correct error.

Applications: Hydraulic servo systems are widely used in the airline, maritime, and military applications. Servo systems capable of automatic position, speed, force control with high accuracy are used in high-speed injection molding, die casting, rolling mills, presses, industrial robots, flight simulators testing machinery and table feeders.

For achieving automation, a feedback signal, using a sensor, from the actuator or any variable to be controlled such as actuator force or velocity or displacement or angle of rotation of a rotary actuator is required. This feedback signal is compared with the reference input and a suitably modified signal is sent to the flow control valve to thereby control the required variable. A block diagram representation of a hydraulic servo system is shown below.

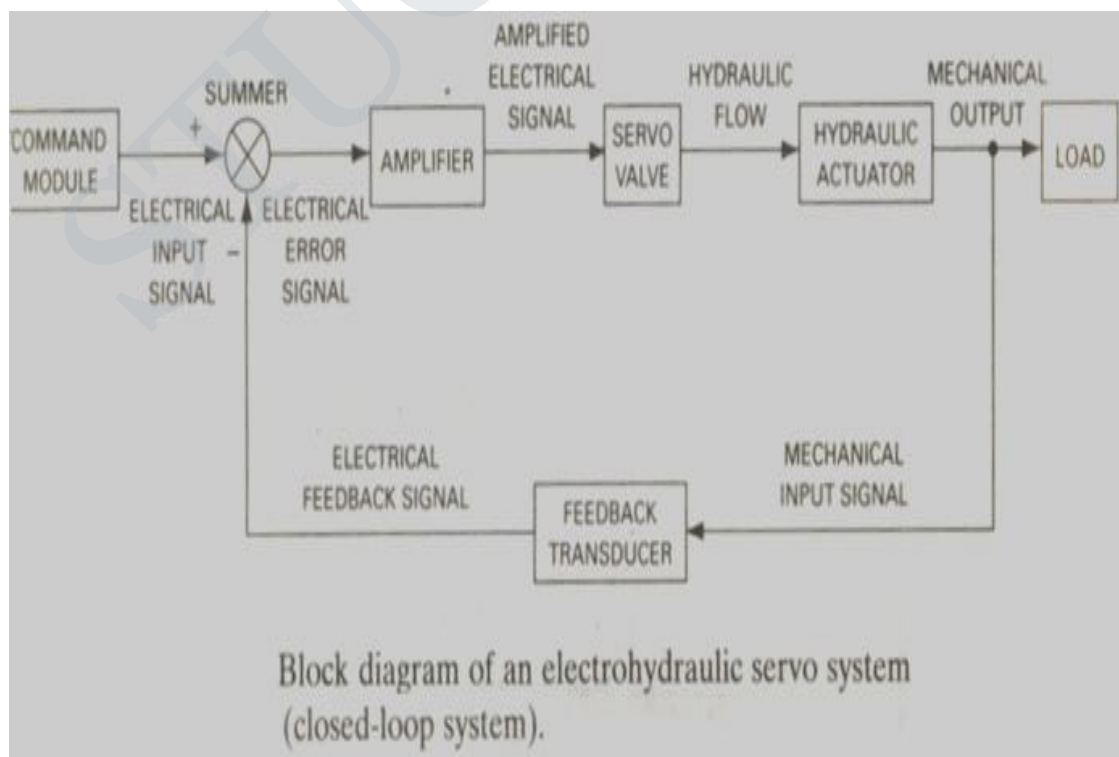

A Mechanical servo system:

In this system shown in the figure, load is connected to the valve spool, and special sensors and electrical components are not required.

Operation:

Input movement to the valve opens the spool (to left) for certain flow rate.

The flow actuates the piston and the load to left.

The load, being connected to the valve body, also moves to left, while the spool is in the same position.

Thus the opening of spool is gradually reduced as the piston moves. When the piston moves by the distance of initial spool movement, spool close the port opening and flow becomes zero. Thus Input movement of spool is related to the load movement. Thus this arrangement provides a feedback signal.

A separate link can be connected to valve spool, cylinder rod and the input, to achieve a ratio of output/ input other than 1.

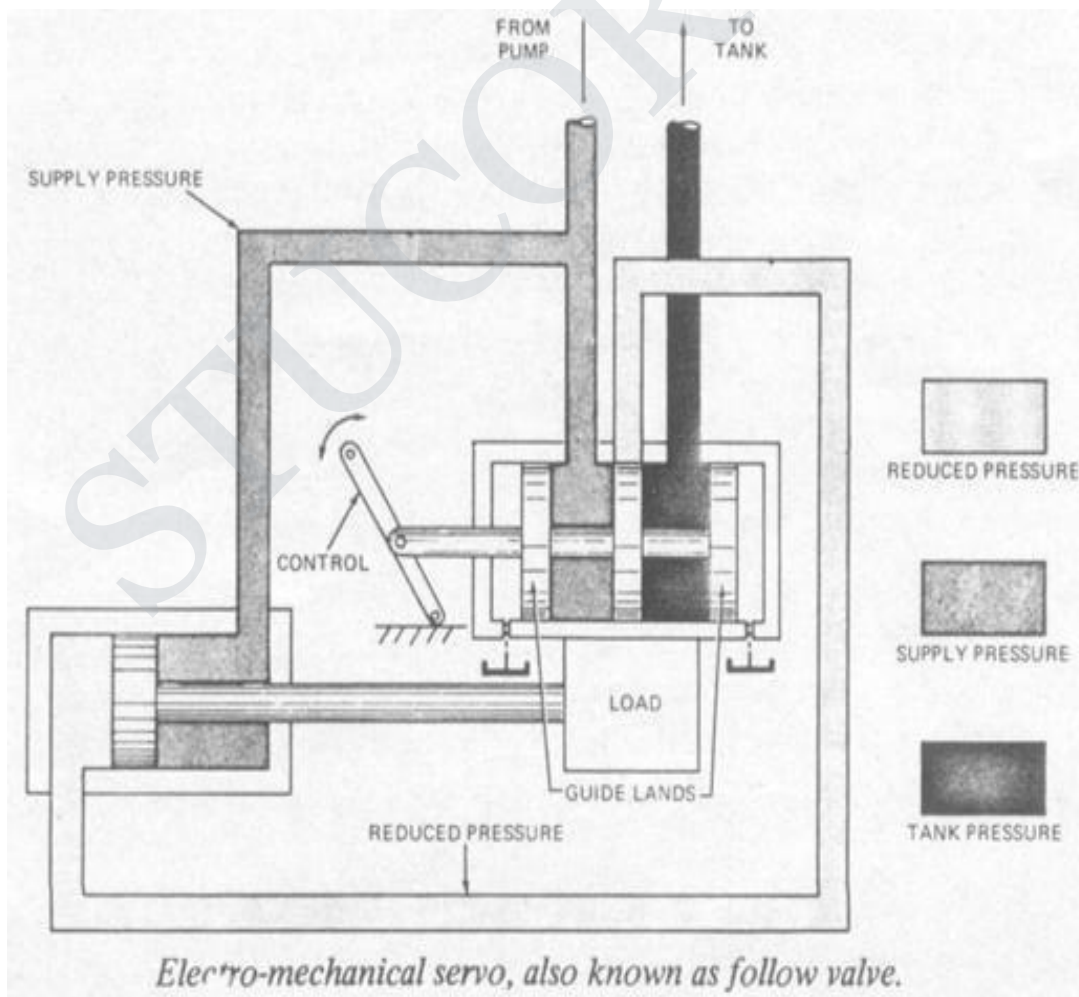

Proportional type valves:

Valves explained so far are on-off type, i.e., they take distinctly one of the two or three positions letting full flow in either direction or stop the flow. However for servo systems valves which operate in an analog fashion, ie continuously variable control are required.

Special valves:

In view of the continuous control, special proportional control valves are used which produce movement of the spool proportional to an electrical signal. The signal given to the valve is the error signal (difference between the reference input and that sensed by the actuator), so that the system corrects to make the error zero, or actuator achieves the desired parameter.

Electrohydraulic Servo System:

For highly accurate control as in aerospace systems and some machine tools, a two- stage electrohydraulic servo valve is used.

In this valve, an electrical input signal operates a torque motor, which turns a flapper which runs between two nozzles > which varies the back pressures at two nozzles > backpressures act at either end of the main spool > which moves the spool and lets certain flow > which in turn moves the flapper at the nozzles in opposite direction to that produced by torque motor > which in turn changes the feedback pressures acting on spool > spool keeps on moving this way till flapper comes to the middle of nozzles, when the back pressures acting on spool are equal > spool movement stops.

With the above sequence of operations, it can be seen that magnitude of spool movement or of the corresponding flow is related to the input current or voltage signal to the servo valve.

These valves are highly accurate but cost can be very high ranging from Rs. 3 to Rs. 10 lakhs and higher.

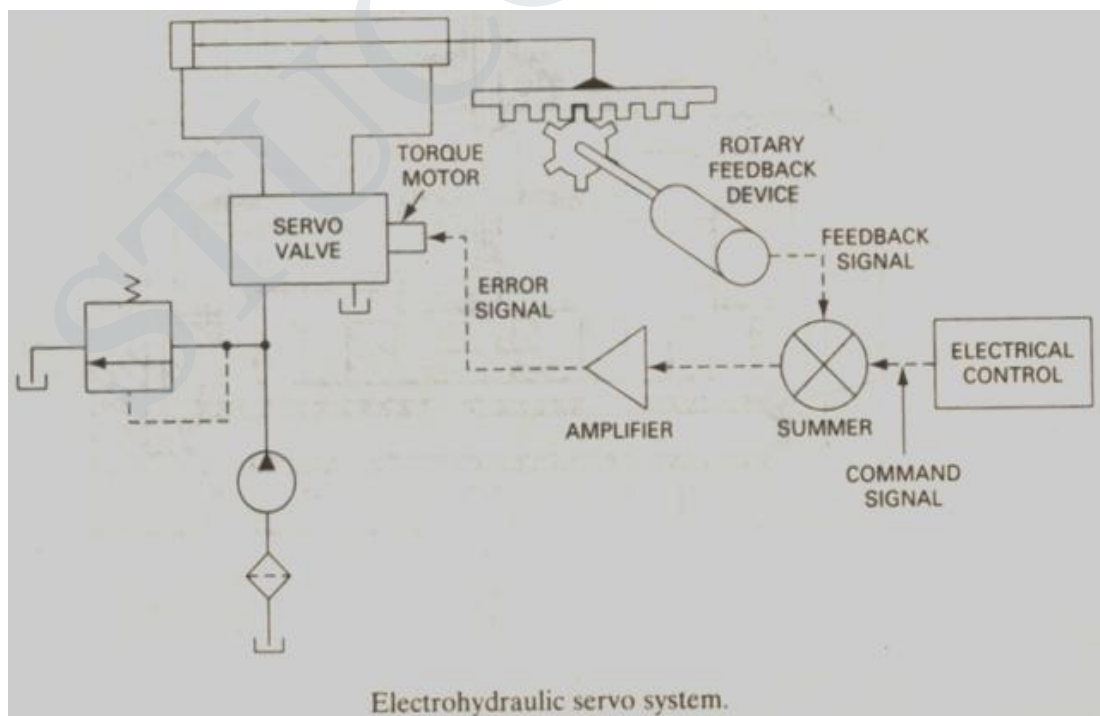
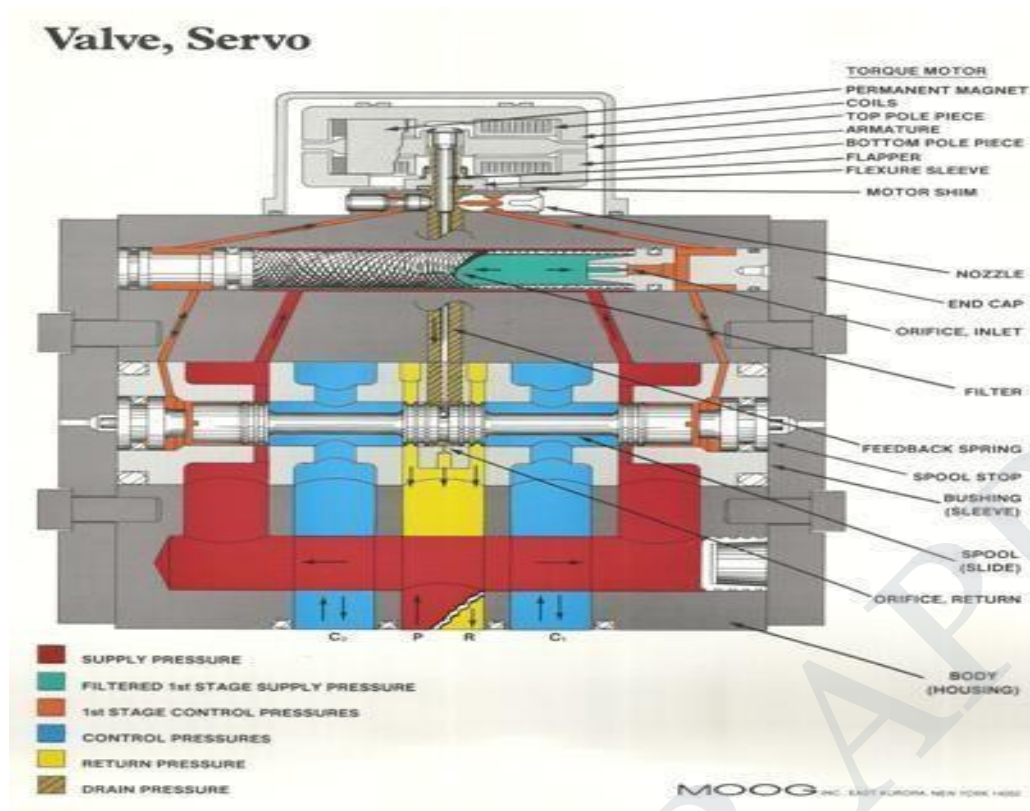

9-3 Electro-Hydraulic Two-Stage Servo Valves

Nearly all types of servo valves are based on common principles. Electro-hydraulic two-stage servo valves generally operate with force feedback. Given that valve pressure drop is constant, the valves control the output flow in proportion to the input signal. Therefore, they can be used to drive a hydraulic cylinder or motor at a speed proportional to the input current.

Figure 9.5 provides illustrations of an electro-hydraulic servo valve. The valve contains identical torque motors in parallel, which serve as a nozzle flapper amplifier with movable coils and nozzles. Coil displacement always determines the spool position. To ensure reliable pilot operation, the valve is provided with a filter prior to the pilot line, as well as a high-performance line filter prior to the valve inlet. Table 9.1 shows valve specifications, and Fig. 9.6 provides frequency response variations.

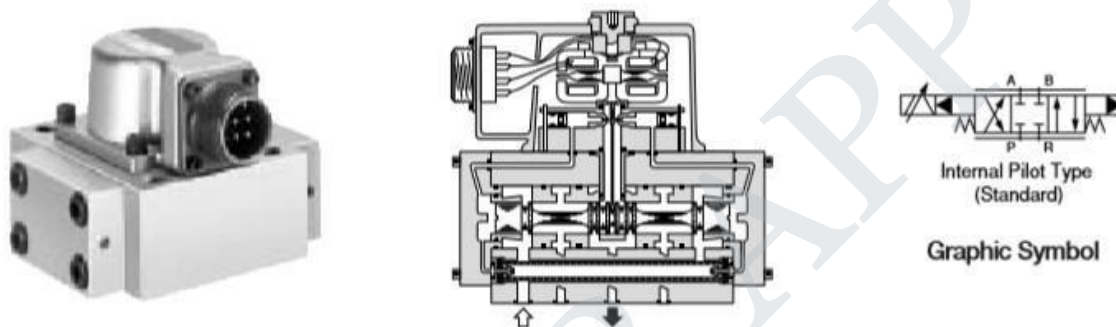

Fig. 9.5 Electro-Hydraulic Servo Valve

9-1 Servomechanism (Tracking Mechanism)

A servomechanism is an automatic control system designed to operate in accordance with input control parameters. The mechanism continuously compares the input signal to the feedback signal to adjust the operating conditions for error correction. Commercially available servo systems vary according to their methods for error detection, amplification, communication, and output.

Hydraulic servo systems have been widely applied in general industrial areas, as well as in the airline, maritime, and military industries. Servo systems, capable of automatic position, speed, and force (load) control with high accuracy and quick response, are used for high-speed injection molding, die-casting, rolling mill, press machines, industrial robots, simulators, testing machinery, and table feeders.

A hydraulic servo system consists of an actuator (hydraulic motor/cylinder), servo valves, sensors, and a servo amplifier, as shown in Fig. 9.1. Figure 9.2 shows a servo system applied to a high-speed vibration test machine.

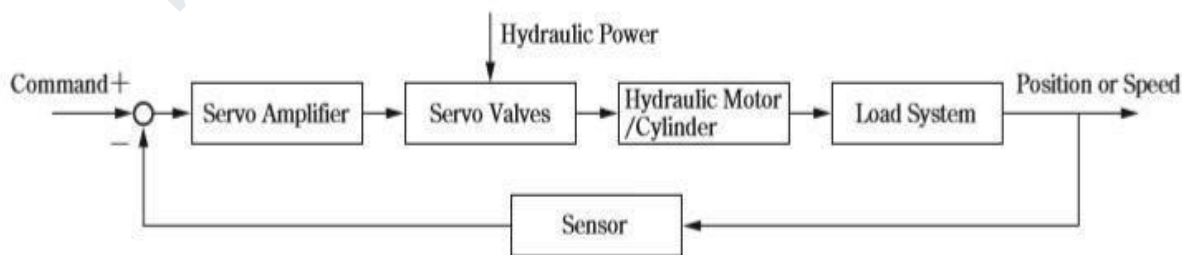

Fig. 9.1 Servo System Configuration

Table 4.2 Spool Types

Spool Type	Graphic Symbol	Valve and Spool (Neutral Position)	Function and Usage
"2" Closed-Center			Maintains the pump pressure and cylinder position in the neutral position. For the two-position type, each port is blocked during the spool transition, causing shock to the system line. This type requires due caution.
"3" Open-Center			Unloads the pump and floats the actuators in the neutral position. For the two-position type, each port is connected to the tank during the spool transition; thus, shock can be reduced.
"4" ABT Connected			Maintains the pump pressure and floats the actuator in the neutral position. The two-position type is used to maintain the system pressure during the spool transition. Shock is reduced compared to the type "2."
"40" ABT Connected, with Throttle			A variation of the type "4," having throttles between A to T and B to T. It can quickly stop the actuator.
"5" PAT Connected			Used to unload the pump in the neutral position and stop the actuator by feeding flow in one way.
"6" PT Connected (Closed during Transition)			Unloads the pump and maintains the actuator in the neutral position. It allows valves to be connected in serial.
"60" PT Connected (Opened during Transition)			A variation of the type "6." Each port is connected to the tank during the spool transition; thus, shock can be reduced.
"7" Center Opened, with Throttle			Mainly used for the two-position type; shock can be reduced during the spool transition.
"8" Two-Way			Maintains the pump pressure and cylinder position in the neutral position, similar to the type "2." Used as a two-way directional control valve.
"9" PAB Connected			Forms a differential circuit in the neutral position.
"10" BT Connected			Prevents one-way minor sliding of the actuator due to leak at the port P in the neutral position.
"11" PA Connected			Blocks one end and feeds flow from the other end to completely stop the actuator in the neutral position.
"12" AT Connected			Able to prevent the actuator from minor one-way sliding due to leak at the port P in the neutral position.

Pressure Control Valve:

Pressure control valve on the hydraulic power unit with pressure relief valve, sequence valve, relief valve, pressure relay-based. Almost each hydraulic power unit complete with a relief valve. Sequence valve, relief valve and pressure switch on some special hydraulic power unit having a sequence of actions and the same system have different working pressures used, such as Dock leveler hydraulic power units for logistics equipment and Paper Cutter production line hydraulic power units.

Relief Valve: Umbrella of hydraulic power unit:

Pressure relief valve on the hydraulic power unit primarily as a security role, limit the maximum pressure to avoid other hydraulic components, pipe damage. As part of a back pressure relief valve in the hydraulic power unit, causing back pressure to increase the stability of motion.

STUCOR APP

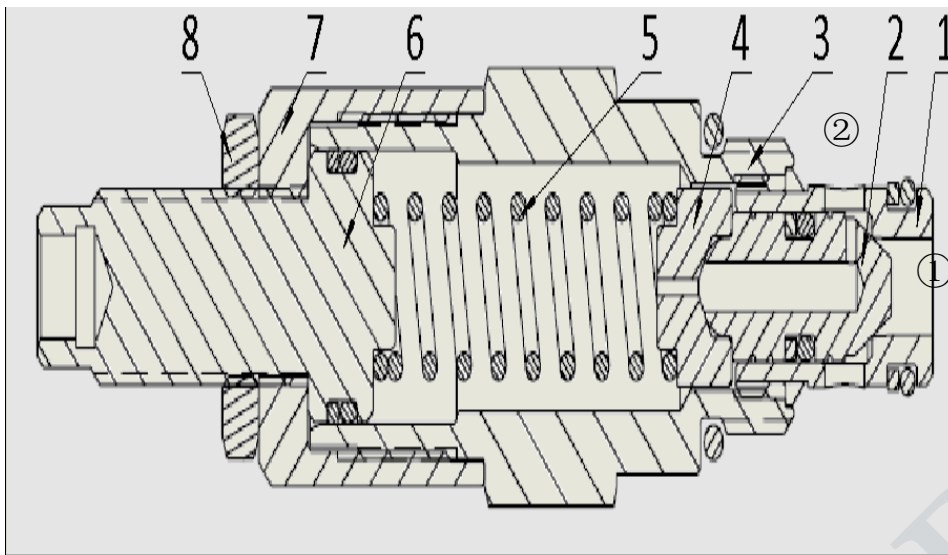

USASI/ISO:

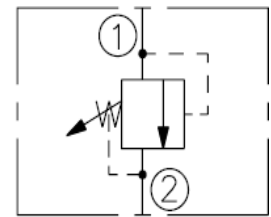

- 1—Valve body 2—valve spool 3—valve body 4—spring seat 5—spring 6—adjusting lever 7—
screw-in body 8—Locking nut

How Relief valve works:

Under normal (1)chamber to chamber (2)closed until the liquid pressure chamber (1)sufficient to overcome the spring force of the valve body from the valve seat, (1)chamber communicating with the chamber (2) the flow of oil from the chamber (1)cavity(2)

Directional Control Valve:

Hydraulic power units varied different types of directional control valve, check valve, P-O-check valve, shuttle valve, solenoid valve, hydraulic control valve, electric proportional valve and so on.

a Check valve –(one-way valve) oil traffic in one-way.

One-way valve is also known as a check valve, which allows fluid only in one direction through the reversing valve closing direction.

The main role of the check valve in the hydraulic power unit are:

To keep the system pressure constant period of time and other pressure retaining components, installation preventing normal operation of the hydraulic pump hydraulic shocks in pump outlet position, the check valve installed in the back part oil used as a back-pressure valve.

According to the role of one-way valve in the hydraulic power unit, his performance was mainly:

- Oil pressure loss circulation of small forward,
- Reverse seal better performance,
- Quick action,
- Low noise.

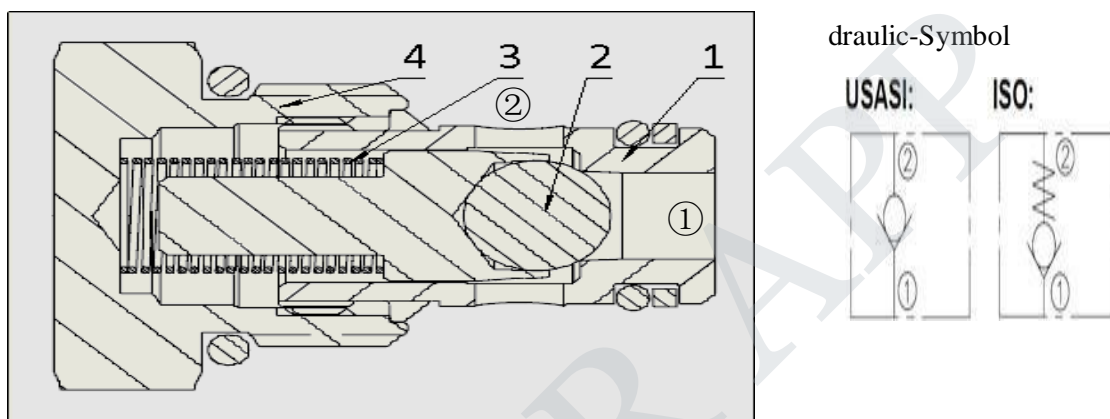

1-Valveseat 2-Checkvalvespool 3-Spring 4-Screw Plug

How Check valve works

The pressure port ① is higher than the pressure port ② plus spring force, the spool is pushed, the channel is open, fluid forward through the check valve (① flow to ②). When the port ② pressure plus the spring force is higher than the port ① pressure spool is pressed against the spring force and fluid pressure on the valve seat, the flow is turned off. b directional valve - oil traffic red and green lights. Directional valve is the largest amount components of Hydraulic power unit request.

Directional valve use of different relative positions in hydraulic power pack. Hydraulic power unit requirements: the oil through a less pressure loss, less amounts of the oil leakage gap between the mouth commutation reliable, sensitive, reversing smoothly without impact.

According to manipulation way valve used in the hydraulic power unit valve can be divided into:

- Manual Valve,
- Solenoid Valve,
- Motorized Valve.

For example, in the automotive lift hydraulic power unit, electric pallet truck hydraulic power unit, electric car pushing hydraulic power unit, hydraulic power units and other Tipper trailers on two two-way solenoid valve with the most.

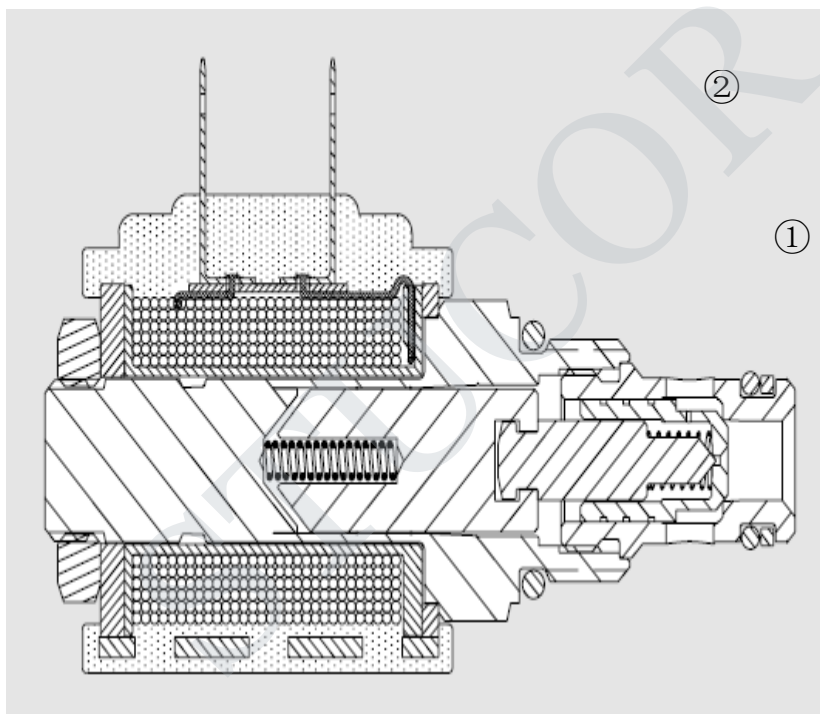

USASI:

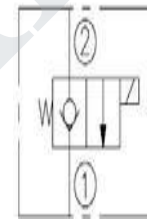

ISO:

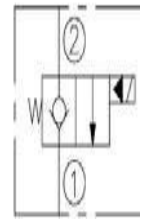

Hydraulic power unit valve

Hydraforce SV type two two-way solenoid valve works

When the solenoid valve coil power, the two two-way solenoid valve can do a one-way valve to allow flow from ① to ② chamber cavity, and the cavity reverse blocking oil from ② to ①. Solenoid valve coil is energized, the lifting force generated by the coil, valve open, fluid chamber from ② to ①, ② and ① chamber to the fluid chamber due to structural reasons strong resistance.

Flow Control Valve:

Flow control valve referred to the flow valve, is by changing the orifice flow area to achieve flow control. It is a control valve components to control the speed of movement of the element. Flow valve can be opened as a small mark of "taps." Flow valve can generally be divided into: a throttle valve, 2-way flow control valve (also known as pressure-compensated flow valve), the three-way flow control valve. Currently on the hydraulic power unit is mainly used Hydraforcecompany NV Throttle and Comatrol's SC13 type 2-way flow valve.

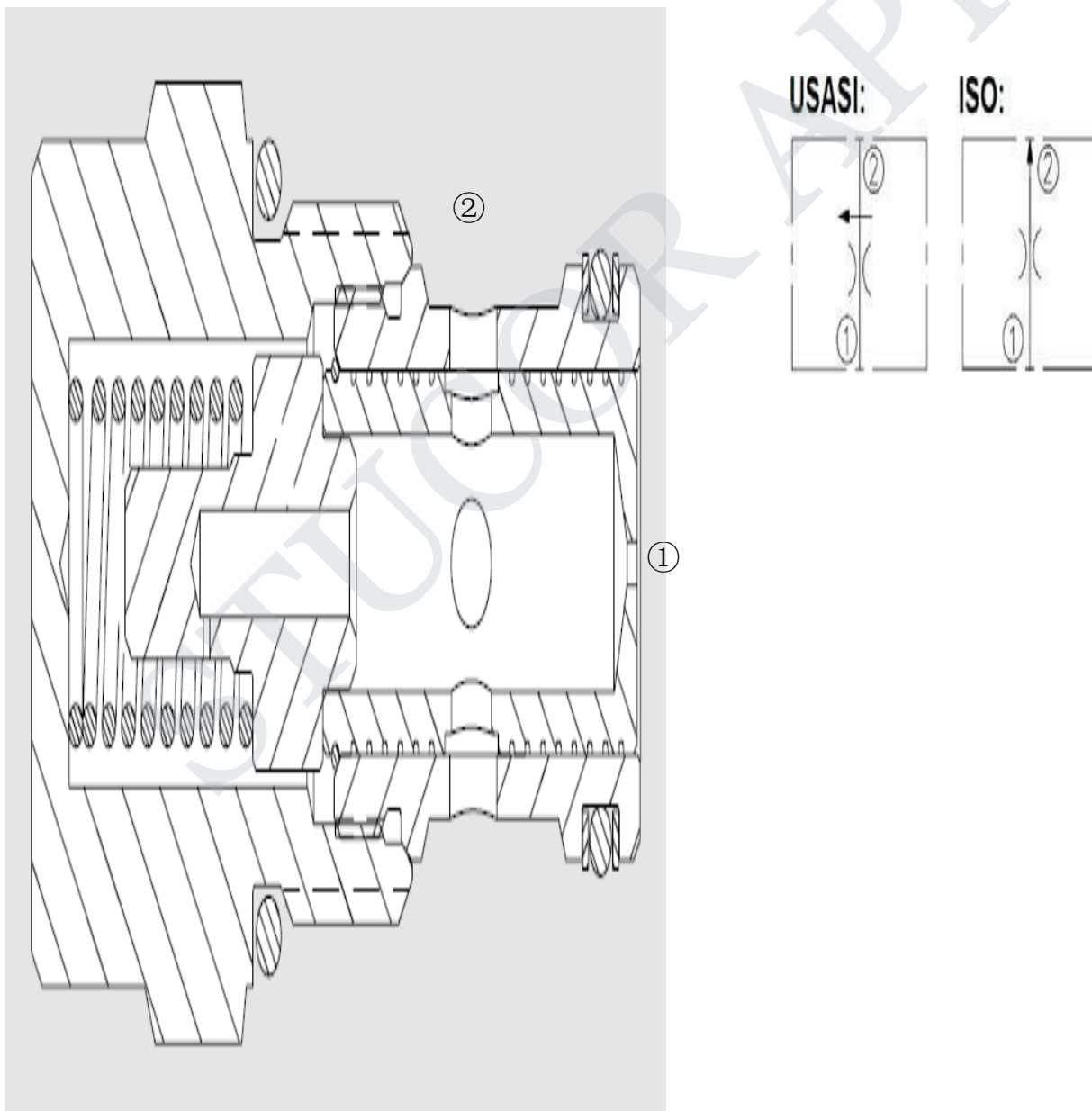

Hydra force FR-type pressure compensated flow control valve works:

FR-type pressure compensated flow control valve (2) from holding chamber effluent flow rate constant and is not affected by the load pressure changes in the circuit downstream of the chamber (2) when the flow through the valve in the control orifice pressure differential created more than 5.5bar, valve begins response to load changes within a pressure range of 7.6 ~ 240bar can maintain accurate flow, reverse flow (chamber (2) to chamber (1)) through the control orifice, no pressure compensation, and orifice same.

Third, the auxiliary section:

Hydraulic auxiliary components of the hydraulic power unit are a "supporting role", but it is also an important part of the hydraulic power unit. Types of hydraulic auxiliary element are varied, including: tank, filter, and suction pipe, return pipe, an intermediate manifold, control switches, pressure gauge, accumulator, and so on. The right choice and ensure the rational use of the hydraulic power unit is reliable, stable and has a very important auxiliary hydraulic components.

Tank - the hydraulic medium required for storage of the hydraulic system, as a heat sink, the role of the liquid medium in air separation and precipitation of impurities.

Filter - filtration of impurities mixed in with the oil, foreign particles in a controlled hydraulic power unit normal operating range, the protection of hydraulic components.

Central manifold - Installation Connecting the motor and gear pump, simplifying the piping, integrated control valve of the hydraulic power unit compact and convenient.

Replace with a different intermediate manifold control valve can be achieved on different principles of hydraulic power unit, which makes the intermediate manifold high versatility.

Cooling Hydraulic Oil: Two types of heat exchanger are used to cool hydraulic oil:

- shell-and-tube and
- finned tube.

The shell-and-tube has a series of tubes inside a closed cylinder. The oil flows through the small tubes, and the fluid receiving the heat (typically water) flows around the small tubes. Routing of the oil can be done to produce a single pass (oil enters one end and exits the other end) or a double pass (oil enters one end, makes a u-turn at the other end, and travels back to exit at the same end it entered).

The finned tube exchanger is used for oil-to-air exchange. The air may be forced through the exchanger with a fan or may flow naturally. If an oil cooler is used on a mobile machine, it is the finned tube type.

Oil coolers are not built to withstand pressure; they are mounted in the return line in an off-line loop. The two options used are the system pump flows oil through the heat exchanger in the return line. This arrangement works well for many circuits. The exchanger is sized to give only a small pressure drop at rated flow. The circuit has a separate low-pressure pump to flow oil through the heat exchanger.

More complex circuits can have significant pressure pulses in the return line. These pulses hammer the heat exchanger and, over time, the joints fracture and begin to leak. If significant (greater than 10 psi) pulses are measured in the return line, the circuit should be used. Here, a separate pump is used to circulate oil from the reservoir through the heat exchanger and back to the reservoir. This circulating pump does not have to build pressure (only the 15 psi or so is required to flow fluid through the exchanger); therefore, it can be an inexpensive design. Any kind of pump is satisfactory if it is rated for the needed flow rate and has seals that are compatible with the fluid properties.

STUCOR APP

UNIT IV PNEUMATIC AND ELECTROPNEUMATIC SYSTEMS

Introduction:

Typical hydraulic circuits for control of industrial machinery are described in this lesson. Graphical hydraulic circuit diagrams incorporating component symbols are used to explain the operation of the circuits.

Basic Components of a Hydraulic System:

Hydraulic systems are power-transmitting assemblies employing pressurized liquid as a fluid for transmitting energy from an energy-generating source to an energy-using point to accomplish useful work.

Figure 1.1 shows a simple circuit of a hydraulic system with basic components.

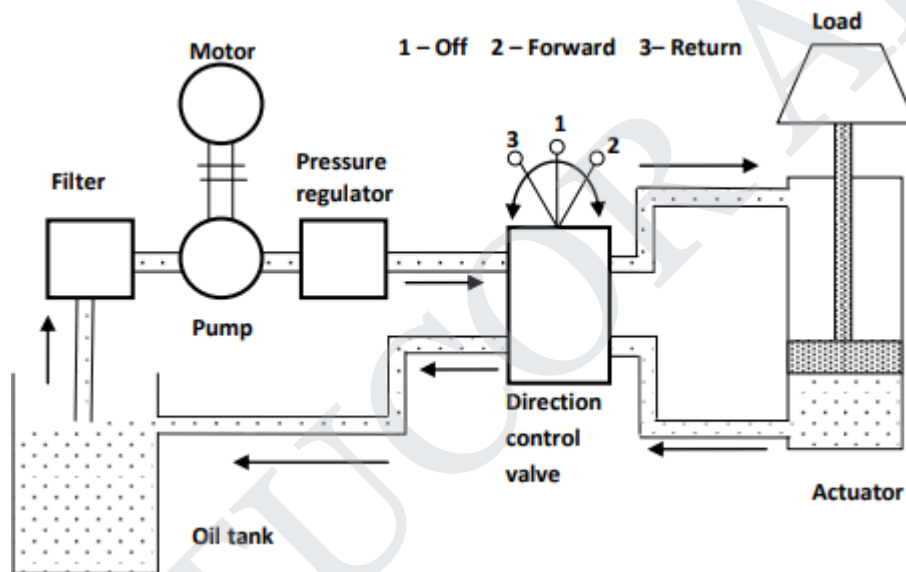

Hydraulic System

Functions of the components shown are as follows:

- The hydraulic actuator is a device used to convert the fluid power into mechanical power to do useful work.
- The actuator may be of the linear type (e.g., hydraulic cylinder) or rotary type (e.g., hydraulic motor) to provide linear or rotary motion, respectively.
- The hydraulic pump is used to force the fluid from the reservoir to rest of the hydraulic circuit by converting mechanical energy into hydraulic energy.

- Valves are used to Pressure regulator
- External power supply (motor) is required to drive the pump.
- Reservoir is used to hold the hydraulic liquid, usually hydraulic oil.
- Piping system carries the hydraulic oil from one place to another.
- Filters are used to remove any foreign particles so as keep the fluid system clean and efficient, as well as avoid damage to the actuator and valves.
- Pressure regulator regulates (i.e., maintains) the required level of pressure in the hydraulic fluid.

The piping is of closed-loop type with fluid transferred from the storage tank to one side of the piston and returned back from the other side of the piston to the tank.

Fluid is drawn from the tank by a pump that produces fluid flow at the required level of pressure. If the fluid pressure exceeds the required level, then the excess fluid returns back to the reservoir and remains there until the pressure acquires the required level. Control the direction, pressure and flow rate of a fluid flowing through the circuit. Motor 1 – Off 2 – Forward 3– Return 3 2 1 Load Direction control valve Pump Oil tank Filter Actuator.

Cylinder movement is controlled by a three-position change over a control valve:

- When the piston of the valve is changed to upper position, the pipe pressure line is connected to port A and thus the load is raised.
- When the position of the valve is changed to lower position, the pipe pressure line is connected to port B and thus the load is lowered.
- When the valve is at center position, it locks the fluid into the cylinder(thereby holding it in position) and dead-ends the fluid line (causing all the pump output fluid to return to tank via the pressure relief).
- In industry, a machine designer conveys the design of hydraulic systems using a circuit diagram.

The components of the hydraulic system using symbols. The working fluid, which is the hydraulic oil, is stored in a reservoir. When the electric motor is switched ON, it runs a positive displacement pump that draws hydraulic oil through a filter and delivers at high pressure. The pressurized oil passes through the regulating valve and does work on actuator. Oil from the other end of the actuator goes back to the tank via return line. To and fro motion of the cylinder is controlled using directional control valve.

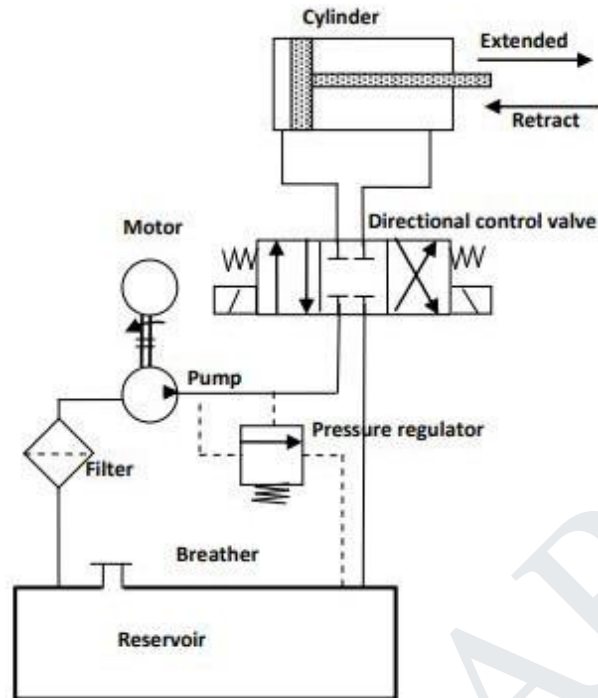

Control Valve

The hydraulic system discussed above can be broken down into four main divisions that are analogous to the four main divisions in an electrical system.

- The power device parallels the electrical generating station.
- The control valves parallel the switches, resistors, timers, pressure switches, relays, etc.
- The lines in which the fluid power flows parallel the electrical lines.
- The fluid power motor (whether it is a rotating or a non-rotating cylinder or a fluid power motor) parallels the solenoids and electrical motors.

Case Study I: Unloading System for Energy Saving

An unloading system is used to divert pump flow to a tank during part of the operational cycle to reduce power demand. This is done to avoid wasting power idle periods. For example, it is often desirable to combine the delivery of two pumps to achieve higher flow rates for higher speed while a cylinder is advancing at low pressure. However, there may be considerable portions of the cycle, such as when the cylinder is moving a heavy load, when the high speed is no longer required, or cannot be sustained by the prime mover. Therefore, one of the two pumps is to be unloaded resulting in a reduction of speed and consequently, power.

The components of this system are:

A, B: Hydraulic pumps,

C, E: Pilot operated spring loaded Relief valves,

D: Check valve.

The hydraulic system discussed above can be broken down into four main divisions that are analogous to the four main divisions in an electrical system.

- The power device parallels the electrical generating station.
- The control valves parallel the switches, resistors, timers, pressure switches, relays, etc.
- The lines in which the fluid power flows parallel the electrical lines.
- The fluid power motor (whether it is a rotating or a non-rotating cylinder or a fluid power motor) parallels the solenoids and electrical motors.

Mode 1: Both Pumps Loaded:

When both pumps are delivering, oil from the pump A passes through the unloading valve C and the check valve D to combine with the pump B output. This continues so long as system pressure is lower than the setting of the unloading valve C.

Mode 2: One pump unloaded:

When system pressure exceeds the setting of the unloading valve C, it makes pump A to discharge to the tank at little pressure. Although the system pressure, supplied by pump B, is high, the check valve prevents flow from B through the unloading valve. Thus only pump B now drives the load at its own delivery rate. Thus the load motion becomes slower but the power demand on the motor M also reduces. If the system pressure goes higher, say because load motion stops, pump B discharges when its relief valve settings would be exceeded.

Points to Ponder: 1

Can you imagine what would happen, if the check valve was not present?

How would you modify the system if you wanted to unload pump B instead of pump A?

Case Study II: Selection of System Operating Pressure

The circuit allow selection of operating pressure limits in a hydraulic system from three options, namely, two maximum pressures, plus venting. First note the components, namely, A: Reservoir with Filter, B: Hydraulic Pump, C, E: Pilot Relief Valve, D: Solenoid activated Four-way Directional valve.

Venting Mode:

Both solenoids a and b of the directional valve D are de-energized. The open- center spool is centered by the valve springs, and the vent port on the relief valve is opened to tank. Therefore, the pump flow opens to tank at a very low pressure.

Intermediate Maximum Operating Pressure:

The left-hand solenoid a of the directional valve is energized. The valve spool is shifted to the leftmost position and connects the relief valve vent port to the remote control valve. Pump flow is now diverted to tank when the pressure setting of the remote valve E is reached.

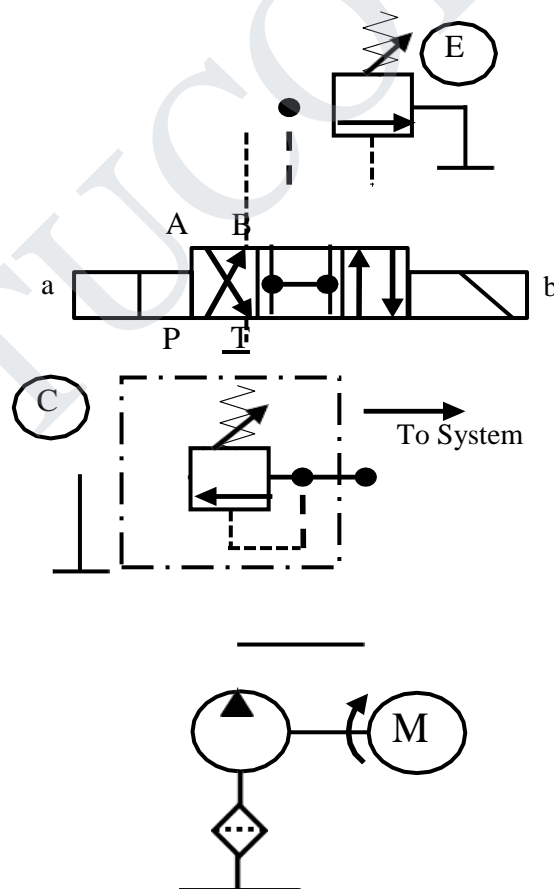

Operating Mode with Intermediate Maximum Operating Pressure

High Maximum Pressure:

The right solenoid b of the directional valve is energized. The spool now shifts right to connect the relief valve vent port to a plugged port in the directional valve. The relief valve C now functions at the setting of its integral pilot stage.

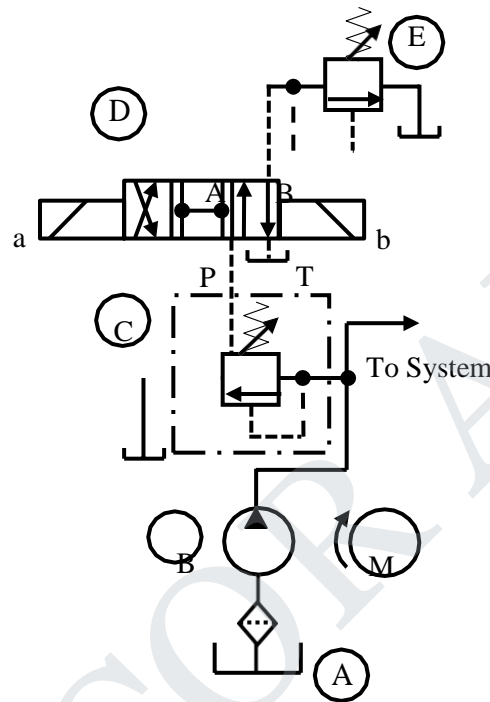

Operating Mode with High Maximum Operating Pressure

Points to Ponder: 2

Why are lines connecting C to D and D to E marked in dashed lines?

Can you briefly describe a scheme to automate the above system such that whenever, in the intermediate pressure mode, pressure setting is exceeded, the system would automatically switch to the low pressure mode?

Case Study III: Reciprocating Cylinder with Automatic Venting at End of Cycle

A reciprocating cylinder drive is a very common hydraulic system. In systems where it is not necessary to hold pressure at the end of a cycle, it is desirable to unload the pump by automatically venting the relief valve, to save energy. Figures 28.5-28.8 show such a system. The system components are : A : Reservoir with Filter, B : Hydraulic pump, C, E : Check valve, D : Pilot operated relief valve, F : Two-position electro-

hydraulic pilot operated Four-way Directional valve, G : Cam operated pilot valve, H : Double acting Single rod Cylinder, I : Limit Switch.

Retraction Stroke:

At the extreme end of the extension stroke, the limit switch is made on by the cylinder rod to break the solenoid circuit for the directional valve F. The directional valve now shifts to its right position and the pump gets connected to the rod end of the cylinder which now retracts. Note that the relief valve vent connection is still blocked.

Automatic Venting at End of Retraction Stroke:

At the extreme end of the retraction stroke, the cam on the cylinder separated by the rod to shift valve G. The relief valve vent port is thus connected, through E and G, to the line from the cap end of the cylinder, and to tank through the F and the inline check valve C. This vents the relief valve D and unloads the pump.

Push Button Start of Cycle:

If another cycle of reciprocating motion is desired, a start button connected to the solenoid circuit is depressed to energize the solenoid, and, in turn, the directional valve shifts to direct pump output into the cap end of the cylinder. This causes the check valve in the vent line to close. Pressure again builds up and the cylinder starts extending. This releases the cam, which, under spring action, shifts and the vent port of E is again blocked at G. Thus the cycle repeats.

Points to Ponder: 3

How does the solenoid get energized if the limit switch is made?

Is the speed of the cylinder going to be equal during extension and retraction? If not, then what decides the speeds?

Case Study IV: Regenerative Reciprocating Circuit

Conventional reciprocating circuits use a four-way directional valve connected directly to a cylinder. In a regenerative reciprocating circuit, oil from the rod end of the cylinder is directed into the cap end to increase speed, without requiring to increase pump flow.

The circuit components are:

A : Hydraulic Pump,

B : Relief valve,

C : Four-way two position solenoid operated valve,

D : Double-acting Single-rod Cylinder.

The operation of the regenerative circuit.

Regenerative Advance:

In Figure 28.9, the —B| port on the directional valve C, which conventionally connects to the cylinder, is plugged and the rod end of the cylinder is connected directly to the pressure line. With the valve shifted to the left most position, the -P| port is connect to the cap end of the cylinder. If the ratio of cap end area to rod end annular area in the cylinder is 2:1, the pressure being the same at both end, the force at the cap end is double that at the rod end. There is therefore a net force on the cylinder to move the load. Similarly, at any speed of the cylinder, the flow into the cap end would be double that of the rod end. However, in this connection, the flow out of the rod end joins pump delivery to increase the cylinder speed. Thus only half of the flow into the cap end is actually supplied by the pump. However, the pressure during advance will be double the pressure required for a conventional arrangement for the same force requirement. This is because the same pressure in the rod end, effective over half the cap end area, opposes the cylinder's advance. In the reverse condition flow from the pump directly enters the rod end of the cylinder through two parallel paths, one through the directional valve and the other directly. Exhaust flow from the cap end returns to the tank conventionally through the directional valve. Note that, in contrast to the conventional case, the force on the cylinder as well as the pump flow remains unchanged during extension and retraction. Thus, the speed of the piston during both advancement and retraction remain same.

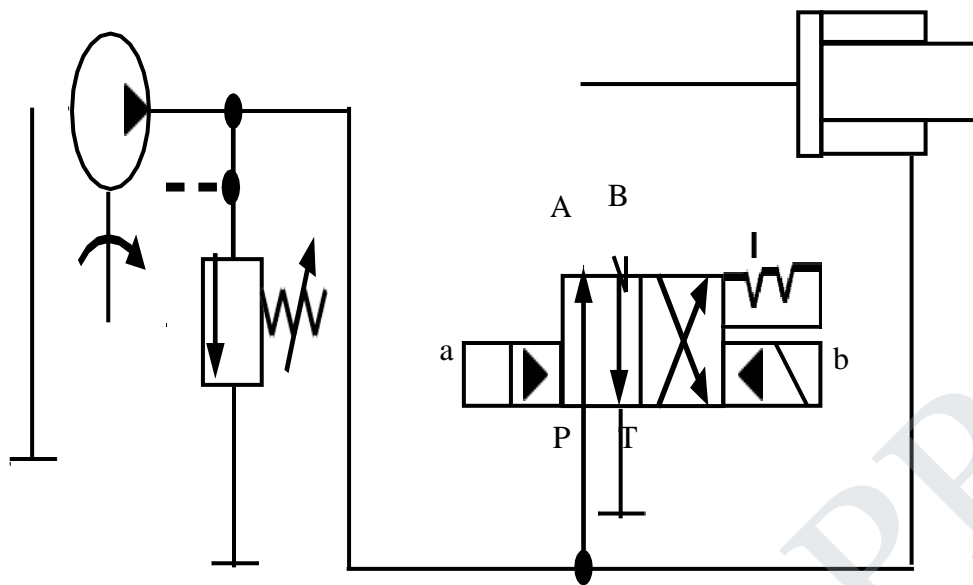

Regenerative Extension Stroke

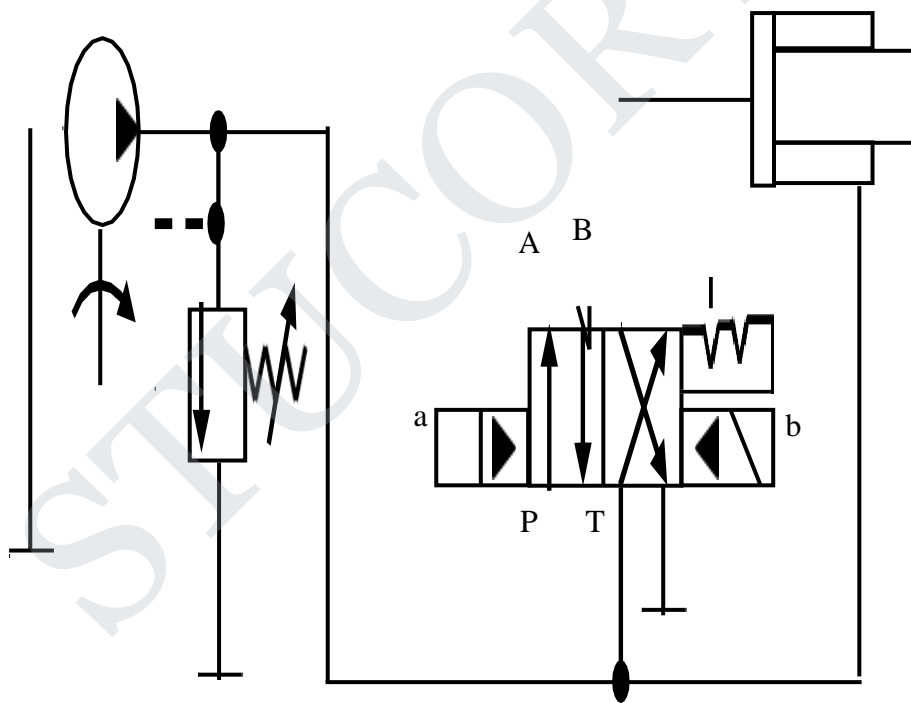

Regenerative Retraction Stroke

Points to Ponder: 4

Explain all parts of the symbol of the directional valve C in Figures 28.9-28.10.

Compare, point by point a regenerative reciprocation circuit with a conventional one.

Case Study V: Sequencing Circuits

In many applications, it is necessary to perform operations in a definite order. Following is one of several such circuits.

The components of the system are as follows:

A : Reservoir and Filter ;

B : Hydraulic Pump ;

C : ; Relief valve : D ;

F1, F2, G : Relief valve with integral check valve ;

H, J : Cylinders ;

I : Check Valve

The sequence of operation realized by the circuit:

Step A – Extend Cylinder H

Step B – Extend Cylinder J while holding pressure on Cylinder H

Step C – Retract Cylinder J

Step D – Retract Cylinder H

Pressing a pushbutton would start the cycle and shift the directional valve E to the position. At first the fluid flows through the integral check valve in G into the cap end of H and returns freely through the check valve in F2. The pump pressure is low during this period, only to the extent of pushing the load on H. Once H reaches its rod end, the pressure builds up and now the flow develops through F1 into the cap end of J and out through the rod end to go back directly to tank through F2, E and C. Note that a pressure equal to the setting of the valve F1 is maintained on H. When J is fully extended, pressure increases further and is limited by the setting of D, providing overload protection to B. Similarly, when the other solenoid of E is energized, the directional valve shifts to the other position. Now, pump delivery is directed through D, E and F2, into the rod end of J. As before, the flow out of the cap end of J flows to tank through F1, E and C.

Accumulators:

A hydraulic accumulator is a device that stores the potential energy of an incompressible fluid held under pressure by an external source against some dynamic force. This dynamic force can come from different

sources. The stored potential energy in the accumulator is a quick secondary source of fluid power capable of doing useful work. There are three basic types of accumulators. The main task of the hydraulic accumulator is to accumulate fluid under pressure and return it when necessary. Since the accumulator contains a fluid under pressure, it is treated as a pressure tank and must therefore be sized for the maximum operating pressure according to test regulations in force in the country where it is installed. To achieve the volume compensation and get the accumulation of energy, the fluid is pre-loaded by a weight, a spring or a compressed gas. Between the pressure of fluid and the counter-pressure exerted by the weight, the spring or the compressed gas must be in a constant state of equilibrium. Weight and spring accumulators are used in industry only in special cases and thus have a relative importance. Gas accumulators without a separating element are rarely used in hydraulics due to the absorption of gas by the fluid. In most of the hydraulic systems are then used the gas accumulators provided with a separating element between gas and fluid. Depending on the type of separating element, we can distinguish bladder, piston and diaphragm accumulators.

Weight-loaded or gravity accumulator:

It is a vertically mounted cylinder with a large weight. When the hydraulic fluid is pumped into it, the weight is raised. The weight applies a force on the piston that generates a pressure on the fluid side of piston. The advantage of this type of accumulator over other types is that it applies a constant pressure on the fluid throughout its range of motion. The main disadvantage is its extremely large size and heavy weight. This makes it unsuitable for mobile application.

Types of Accumulators with Separating Element:

Spring-loaded accumulator:

A spring-loaded accumulator stores energy in the form of a compressed spring. A hydraulic fluid is pumped into the accumulator, causing the piston to move up and compress the spring. The compressed spring then applies a force on the piston that exerts a pressure on the hydraulic fluid. This type of accumulator delivers only a small volume of oil at relatively low pressure. Furthermore, the pressure exerted on the oil is not constant as in the dead-weight-type accumulator. As the springs are compressed, the accumulator pressure reaches its peak, and as the springs approaches their free lengths, the accumulator pressure drops to a

minimum.

Gas-loaded accumulator:

A gas-loaded accumulator is popularly used in industries. Here the force is applied to the oil using compressed air. Schematic diagram of a gas loaded accumulator. A gas accumulator can be very large and is often used with water or high water-based fluids using air as a gas charge. Typical application is on water turbines to absorb pressure surges owing to valve closure and on ram pumps to smooth out the delivery flow. The exact shape of the accumulator characteristic curve depends on pressure–volume relations.

Piston-type accumulator:

It consists of a cylinder with a freely floating piston with proper seals. Its operation begins by charging the gas chamber with a gas (nitrogen) under a pre-determined pressure. This causes the free sliding piston to move down. Once the accumulator is pre-charged, a hydraulic fluid can be pumped into the hydraulic fluid port. As the fluid enters the accumulator, it causes the piston to slide up, thereby compressing the gas that increases its pressure and this pressure is then applied to the hydraulic fluid through the piston. Because the piston is free sliding, the pressure on the gas and that on the hydraulic fluid are always equal.

Diaphragm accumulator:

In this type, the hydraulic fluid and nitrogen gas are separated by a synthetic rubber diaphragm.. The advantage of a diaphragm accumulator over a piston accumulator is that it has no sliding surface that requires lubrication and can therefore be used with fluids having poor lubricating qualities. It is less sensitive to contamination due to lack of any close-fitting components.

Bladder accumulator:

It functions in the same way as the other two accumulators.. Here the gas and the hydraulic fluid are separated by a synthetic rubber bladder. The bladder is filled with nitrogen until the designed precharge pressure is achieved. The hydraulic fluid is then pumped into the accumulator, thereby compressing the gas and increasing the pressure in the accumulator. The port cover is a small piece of metal that protects the bladder from damage as it expands and contacts the fluid port.

These accumulators consist of a fluid zone, a gas zone and a separating gas-tight element. The fluid area is in contact with the circuit. With the pressure increases, a certain volume of fluid enters into the accumulator and compresses the gases.

In the hydraulic systems, are used with the following accumulators with a separating element:

- bladder accumulators
- piston accumulators

Bladder Accumulators:

In the bladder accumulators, the fluid area is separated from the gas area by a flexible bladder. The fluid around the bladder is in contact with the circuit, so any increase in pressure causes the entry of the fluid into the accumulator and thereby compresses the gas. Vice versa, every drop of pressure in the circuit causes the expansion of the gas, resulting in delivery of the fluid from the accumulator to the circuit. Bladder accumulators can be installed in vertical position (preferable), in horizontal one and, under certain operating conditions, also in an inclined one. In the inclined and vertical positions, the valve on the fluid side should face down. The bladder accumulators include a pressure welded or forged vessel, a flexible bladder and the fittings for gas and oil.

Piston Accumulators:

In the piston accumulators, the fluid area is separated from the gas area from a metal piston fitted with gas tight seals. The gas area is filled with nitrogen. The fluid zone is connected to the hydraulic system, so any increase in pressure in the circuit causes the entry of fluid in the accumulator resulting in compression of the gas. Vice versa, at every drop of pressure in the circuit, the compressed gas contained in the accumulator expands and the accumulator delivers the fluid to circuit. The piston accumulators can operate in any position, but it is preferable to mount them with the gas area upwards in order to prevent that solid contaminants contained in the fluid settle by gravity on the piston seals. The typical structure of the piston accumulator includes a cylindrical pipe, a piston with seals, end caps in which there are the fluid side and gas side connections. The pipe serves to resist to the internal pressure and to drive the piston. To ensure that the pressures of the two chambers are as balanced as possible, during the movement, it's necessary that the friction between the piston and the pipe is minimized. For this reason, the inner surface of the pipe must be

honed. In practice, however, the friction between the piston seals and the pipe creates, between gas area and fluid one, a pressure difference that, however, can be limited to 1 bar with appropriate selection of seals. The position of the piston can be shown continuously through a passing rod. By fixing a cam to the rod, you can also take advantage of the movement of the piston in order to control through limit switches the switching on or switching off of the pump.

Accumulator Selections :

When selecting an accumulator for a particular application, both system and performance criteria should be taken into account. To ensure long and satisfactory service life, the following factors should be taken into account.

- failure modes
- flow rate
- response time
- high frequency cycling
- external forces
- output volume
- fluid type
- shock suppression
- sizing information
- temperature effect
- safety
- certification.

Failure Prevention:

Accumulator failure is generally defined as inability to accept and exhaust a specified amount of fluid when operating over a specific system pressure range. Failure often results from an unwanted loss or gain of pre-charge pressure. It cannot be too highly stressed that the correct pre-charge pressure is the most important factor in prolonging accumulator life. If maintenance of the pre-charge pressure and relief valve settings are neglected and if system pressures are adjusted without making corresponding adjustments to pre-charge

UNIT -V TROUBLE SHOOTING AND APPLICATIONS

Industrial Automation vs. Industrial Information Technology

Industrial Automation makes extensive use of Information Technology. Fig. 1.1 below shows some of the major IT areas that are used in the context of Industrial Automation.

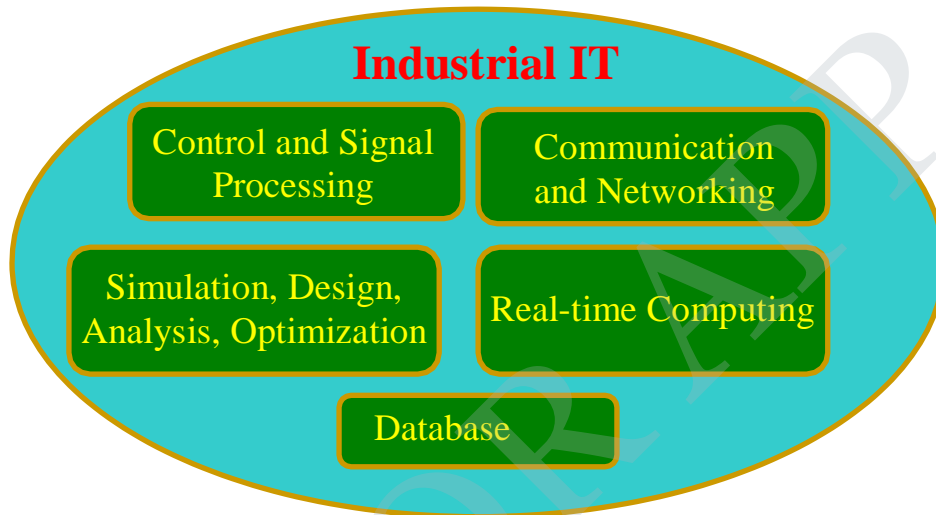

Major areas of IT which are used in the context of Industrial Automation.

Point to Ponder: 3

Try to find an example automated system which uses at least one of the areas of Industrial IT .

However, Industrial Automation is distinct from IT in the following senses

Industrial Automation also involves significant amount of hardware technologies, related to Instrumentation and Sensing, Actuation and Drives, Electronics for Signal Conditioning, Communication and Display, Embedded as well as Stand-alone Computing Systems etc.

As Industrial Automation systems grow more sophisticated in terms of the knowledge and algorithms they use, as they encompass larger areas of operation comprising several units or the whole of a factory, or even several of them, and as they integrate manufacturing with other areas of business, such as, sales and

customer care, finance and the entire supply chain of the business, the usage of IT increases dramatically. However, the lower level Automation Systems that only deal with individual or , at best, a group of machines, make less use of IT and more of hardware, electronics and embedded computing.

Point to Ponder: 4

Apart from the above, there are some other distinguishing features of IT for the factory that differentiate it with its more ubiquitous counterparts that are used in offices and other business. Industrial information systems are generally reactive in the sense that they receive stimuli from their universe of discourse and in turn produce responses that stimulate its environment. Naturally, a crucial component of an industrial information system is its interface to the world. Most of industrial information systems have to be real-time. By that we mean that the computation not only has to be correct, but also must be produced in time. An accurate result, which is not timely may be less preferable than a less accurate result produced in time. Therefore systems have to be designed with explicit considerations of meeting computing time deadlines.

Many industrial information systems are considered mission-critical, in the sense that the malfunctioning can bring about catastrophic consequences in terms of loss of human life or property. Therefore extraordinary care must be exercised during their design to make them flawless. In spite of that, elaborate mechanisms are often deployed to ensure that any unforeseen circumstances can also be handled in a predictable manner. Fault-tolerance to emergencies due to hardware and software faults must often be built in.

Point to Ponder: 5

Role of automation in industry:

Manufacturing processes, basically, produce finished product from raw/unfinished material using energy, manpower and equipment and infrastructure. Since an industry is essentially a —systematic economic activityl, the fundamental objective of any industry is to make profit.

Roughly speaking, $\text{Profit} = (\text{Price/unit} - \text{Cost/unit}) \times \text{Production Volume}$

So profit can be maximized by producing good quality products, which may sell at higher price, in larger volumes with less production cost and time. The major parameters that affect the cost/unit of a mass-

manufactured industrial product.

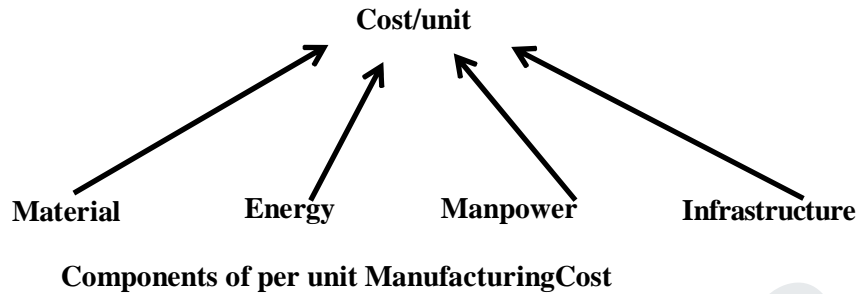

Automation can achieve all these in the following ways,

The overall production time for a product is affected by various factors. Automation affects all of these factors. Firstly, automated machines have significantly lower production times. For example, in machine tools, manufacturing a variety of parts, significant setup times are needed for setting the operational configuration and parameters whenever a new part is loaded into the machine. This can lead to significant unproductive for expensive machines when a variety of products is manufactured. In Computer Numerically Controlled (CNC) Machining Centers set up time is reduced significantly with the help of Automated Tool Changers, Automatic Control of Machines from a Part Program loaded in the machine computer. Such a machine is shown. The consequent increase in actual metal cutting time results in reduced capital cost and an increased volume of production.

Point to Ponder: 6

The following automation systems improve industrial profitability.

- Automated Welding Robots for Cars
- Automated PCB Assembly Machines
- Distributed Control Systems for Petroleum Refineries



A CNC Machine with an Automated Tool Changer and the Operator Console with Display for Programming and Control of the Machine

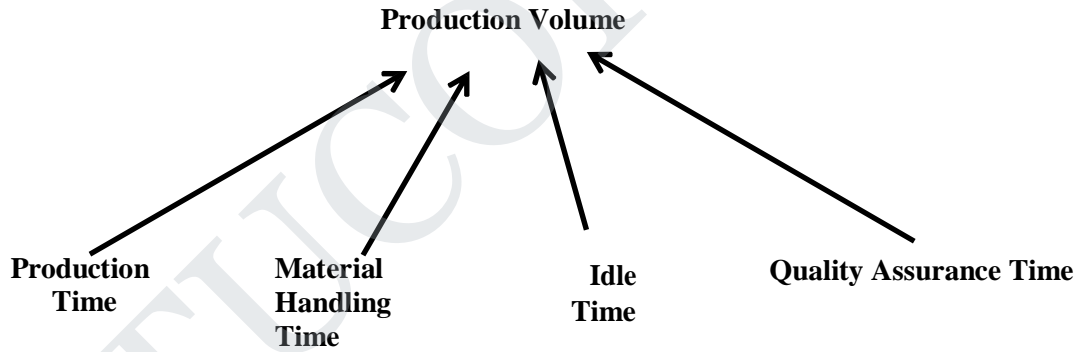

The product quality that can be achieved with automated precision machines and processes cannot be achieved with manual operations. Moreover, since operation is automated, the same quality would be achieved for thousands of parts with little variation. Industrial Products go through their life cycles, which consists of various stages. At first, a product is conceived based on Market feedbacks, as well as Research and Development Activities. Once conceived the product is designed. Prototype Manufacturing is generally needed to prove the design. Once the design is proved, Production Planning and Installation must be carried out to ensure that the necessary resources and strategies for mass manufacturing are in place.

This is followed by the actual manufacture and quality control activities through which the product is mass-produced. This is followed by a number of commercial activities through which the product is actually sold in the market.

Automation also reduces the overall product life cycle i.e., the time required to complete

- Product conception and design
- Process planning and installation
- Various stages of the product life cycle



A Typical Industrial Product Life Cycle

Economy of Scale and Economy of Scope:

In the context of Industrial Manufacturing Automation, Economy of Scale is defined as follows.

Economy of Scale

Definition: Reduction in cost per unit resulting from increased production, realized through operational efficiencies. Economies of scale can be accomplished because as production increases, the cost of producing each additional unit falls.

Obviously, Automation facilitates economy of scale, since, as explained above, it enables efficient large-scale production. In the modern industrial scenario however, another kind of economy, called the economy of scope assumes significance.

Economy of Scope

Definition : The situation that arises when the cost of being able manufacture multiple products simultaneously proves more efficient than that of being able manufacture single product at a time.

Economy of scope arises in several sectors of manufacturing, but perhaps the most predominantly in electronic product manufacturing where complete product life cycle, from conception to market, are executed in a matter of months, if not weeks. Therefore, to shrink the time to market drastically use of automated tools is mandated in all phases of the product life cycle. Additionally, since a wide variety of products need to be manufactured within the life period of a factory, rapid programmability and reconfigurability of machines and processes becomes a key requirement for commercial success. Such an automated production system also enables the industry to exploit a much larger market and also protects itself against fluctuations in demand for a given class of products. Indeed it is being driven by the economy of scope, and enabled by Industrial Automation Technology that Flexible Manufacturing (i.e. producing various products with the same machine) has been conceived to increase the scope of manufacturing.

Next let us see the various major kinds of production systems, or factories, exist. This would be followed

by a discussion on the various types of automation systems that are appropriate for each of these categories.

Point to Ponder: 7

Types of production systems:

Major industrial processes can be categorized as follows based on their scale and scope of production.

Continuous flow process: Manufactured product is in continuous quantities i.e., the product is not a discrete object. Moreover, for such processes, the volume of production is generally very high, while the product variation is relatively low. Typical examples of such processes include Oil Refineries, Iron and Steel Plants, Cement and Chemical Plants.

Mass Manufacturing of Discrete Products: Products are discrete objects and manufactured in large volumes. Product variation is very limited. Typical examples are Appliances, Automobiles etc.

Batch Production: In a batch production process the product is either discrete or continuous. However, the variation in product types is larger than in continuous-flow processes. The same set of equipment is used to manufacture all the product types. However for each batch of a given product type a distinct set of operating parameters must be established. This set is often referred to as the —recipe for the batch. Typical examples here would be Pharmaceuticals, Casting Foundries, Plastic moulding, Printing etc.

Job shop Production: Typically designed for manufacturing small quantities of discrete products, which are custom built, generally according to drawings supplied by customers. Any variation in the product can be made. Examples include Machine Shops, Prototyping facilities etc.

The above types of production systems are shown in Figure 1.6 categorized according to volumes of production and variability in product types. In general, if the quantity of product is more there is little variation in the product and more varieties of product is manufactured if the quantity of product is lesser.

Types of Automation Systems:

Automation systems can be categorized based on the flexibility and level of integration in manufacturing process operations. Various automation systems can be classified as follows

Fixed Automation: It is used in high volume production with dedicated equipment, which has a fixed set of operation and designed to be efficient for this set. Continuous flow and Discrete Mass Production systems use this automation. e.g. Distillation Process, Conveyors, Paint Shops, Transfer lines etc.

A process using mechanized machinery to perform fixed and repetitive operations in order to produce a

high volume of similar parts.

Programmable Automation:

It is used for a changeable sequence of operation and configuration of the machines using electronic controls. However, non-trivial programming effort may be needed to reprogram the machine or sequence of operations. Investment on programmable equipment is less, as production process is not changed frequently. It is typically used in Batch process where job variety is low and product volume is medium to high, and sometimes in mass production also. e.g. in Steel Rolling Mills, Paper Mills etc.

Flexible Automation:

It is used in Flexible Manufacturing Systems (FMS) which is invariably computer controlled. Human operators give high-level commands in the form of codes entered into computer identifying product and its location in the sequence and the lower level changes are done automatically. Each production machine receives settings/instructions from computer. These automatically loads/unloads required tools and carries out their processing instructions. After processing, products are automatically transferred to next machine. It is typically used in job shops and batch processes where product varieties are high and job volumes are medium to low. Such systems typically use Multipurpose CNC machines, Automated Guided Vehicles (AGV) etc.

Integrated Automation:

It denotes complete automation of a manufacturing plant, with all processes functioning under computer control and under coordination through digital information processing. It includes technologies such as computer-aided design and manufacturing, computer-aided process planning, computer numerical control machine tools, flexible machining systems, automated storage and retrieval systems, automated material handling systems such as robots and automated cranes and conveyors, computerized scheduling and production control. It may also integrate a business system through a common database. In other words, it symbolizes full integration of process and management operations using information and communication technologies. Typical examples of such technologies are seen in Advanced Process Automation Systems and Computer Integrated Manufacturing (CIM). As can be seen from above, from Fixed Automation to CIM the scope and complexity of automation systems are increasing. Degree of automation necessary for an individual manufacturing facility depends on manufacturing and assembly specifications, labor conditions and competitive pressure, labor cost and work requirements. One must remember that the

investment on automation must be justified by the consequent increase in profitability. To exemplify, the appropriate contexts for Fixed and Flexible Automation are compared and contrasted. Fixed automation is appropriate in the following circumstances. Low variability in product type as also in size, shape, part count and material. Predictable and stable demand for 2- to 5-year time period, so that manufacturing capacity requirement is also stable. High production volume desired per unit time. Significant cost pressures due to competitive market conditions. So automation systems should be tuned to perform optimally for the particular product. Flexible automation, on the other hand is used in the following situations. Significant variability in product type. Product mix requires a combination of different parts and products to be manufactured from the same production system. Product life cycles are short. Frequent upgradation and design modifications alter production requirements. Production volumes are moderate, and demand is not as predictable.

Point to Ponder: 8

- Light bulbs
- Garments
- Textile
- Cement
- Printing
- Pharmaceuticals
- Toys

Pressure-control valves:

A pressure-relief valve at the pumps automatically protects the system from overpressure. An unloading valve dumps the high-volume pump to tank after reaching a preset pressure. A kick-down sequence pressure-control valve forces all oil to the cylinder until it reaches a preset pressure. After reaching this pressure, the valve opens and sends all pump flow to the hydraulic motor first. A sequence valve upstream from the rotary actuator keeps it from moving until the hydraulic motor stalls against its load. A pressure-reducing valve ahead of the hydraulic motor allows the operator to set maximum torque by adjusting pressure to the motor inlet. Another pressure-control valve -called a counterbalance valve - located in the rod end line of the main cylinder keeps it from running away when the directional control valve shifts. The

counterbalance valve is adjusted to a pressure that keeps the cylinder from extending, even when weight on its rod could cause this to happen.

Parallel and series circuits:

There are parallel and series type circuits in fluid power systems. Pneumatic and hydraulic circuits may be parallel type, while only hydraulic circuits are series type. However, in industrial applications, more than 95% of hydraulic circuits are the parallel type. All pneumatic circuits are parallel design because air is compressible it is not practical to use it in series circuits. In parallel circuits, fluid can be directed to all actuators simultaneously. Hydraulic parallel circuits usually consist of one pump feeding multiple directional valves that operate actuators one at a time or several in unison. Hydraulics and pneumatics will be a familiar topic for you. Both work using the same principle, Pascal's law to generate force or motion. The major difference between these two power transferring technique is the medium used. For hydraulics, incompressible fluids are used and for pneumatics, compressed gases are used. The article Hydraulics and Pneumatics will be one useful article if you want to study the difference between these. In general, hydraulic systems are used for precise controlling of large force applications and pneumatic systems for lightweight and speedy applications. Hydraulic-based components are made using steel and pneumatic components are made using plastics and non-ferrous materials. Hydraulics and pneumatics have similar functions and working principle. The points provide Hydraulics and pneumatics have similar functions and working principle. The points provided here will help you to choose the right technique for your application.

- Consider the environment of your application(temperature, pressure, etc..)
- Hydraulics is more expensive.
- Hydraulics utilize less energy than pneumatics
- Hydraulic equipment requires a power pack for installation and pneumatic equipment can be plugged into a ring main.
- Hydraulics is suitable for high-pressure applications
- Hydraulics requires more complicated assemblies and repairing process.

Now, in this article, we can discuss applications of hydraulics and pneumatics. Most of the stationary or mobile equipment you use in your daily life is an application of hydraulics and pneumatics. It is impossible to mention each and every example. Some of the daily used hydraulics and pneumatics applications are

listed below.

Hydraulics Applications:

Industrial:

Electrohydraulic is the mechanism used for controlling the industrial applications of hydraulics. Precise and fast response is an advantage of this. Plastic processing machinery, steel making and primary metal extraction applications, automated production lines, machine tool industry, paper industries, loaders, crushers, presses, textile industry machinery, etc. are some of the examples of industrial hydraulics.

Mobile Hydraulics:

In mobile hydraulics, the hydraulic system is controlled manually. Building and construction equipment like cranes, excavators, backhoe, earth moving equipment, etc., tractors, irrigation system, material handling equipment, tunnel boring equipment, rail equipment, etc. are some examples of mobile hydraulics.

Automobiles:

Hydraulics have many interesting applications in the automobile industry. Most of the important work using the principle of hydraulics. Power steering, shock absorbers, windshields, and brake are the common applications of hydraulics in vehicles. Two-post lifts and four-post lifts are used in the automobile industry to lift vehicles for servicing and inspecting.

Marine Applications:

Hydraulics plays an important role in maintaining the stability and control of ships. Steering gears, bow and stern thrusters, engine room maintenance systems including pumps and jacks, deck machineries like cranes, winches, hatch covers, mooring drums and others are examples of hydraulics in the marine industry.

Aerospace Applications:

Airplanes, rockets, spaceships, etc. Use hydraulic systems for various applications. Aerospace industry uses hydraulics for adjusting wings, retraction and extension of landing gears, opening/closing of doors, brakes, steering, etc.

Mining:

Hydraulic fracturing is one of the advanced mining technology used for extracting unused gases/oils beneath the earth surface. In this approach, a high-pressure mixture of water, sand and other chemical additives are passed into the cracks.

- Fundamentals of hydraulics: Basics of water and oil hydraulics
- Hydraulic system accessories: Reservoirs, filters, coolers, Instrumentation and accumulators
- Principle construction and working of components
- Hydraulic pumps: Pump basics positive & non-positive displacement pumps
- Pressure control: relief, reducing, regulating valves
- Flow control: FCV, non-return valves
- Actuators: Linear actuators, hydraulic motors, Hydraulic drives.
- Direction control valves: Direct operated, pilot operated
- ISO symbol and hydraulic circuit reading
- Performance evaluation and testing of Hydraulic pumps, Relief & DC valves
- Principle of solenoid valves
- Working principles of proportional valves and servo valves
- Interpretation and discussions of electro-hydraulic circuits in plant machinery
- Material handling system
- Proportional variable pump control system
- General troubleshooting and maintenance

Pneumatics Applications:**Automobile:**

Automobile industry use pneumatic systems for dismantling vehicle tire, filling compressed air in the tire, vehicle painting, opening and closing of doors, air brakes on heavy vehicles, etc.

Transporting Goods:

Pneumatics is used to transport goods from shelf to other location inside the company. The cylinder will push the item on the shelf into the moving belt if the button is pushed.

Industrial Applications:

Material handling, drilling, sawing, filling, packaging, clamping, shifting, etc. are some of the general applications of the pneumatic system.

Theories of compressed air:

- Operation & function of Pneumatic system components
- Design & drawing of air symbols
- Simulation of movement phases & function phases
- Drawing air circuits according to standards
- Dryers, air receivers
- Compressors
- Pneumatic actuators
- Air distribution systems
- Directional valves
- Flow valves
- Fault-finding & trouble shooting of compressed air control circuits
- Guidelines for industrial safety

Hydraulic and pneumatic circuit:**Design Considerations :****Safety of Operation :**

1. Pressure and Temperature ratings.
2. Interlocks for sequential operations
3. Emergency shutdown features.
4. Power failure locks.
5. Operation speed.
6. Environment conditions.

Meet functional requirements :

1. Meet required performance specification.

2. Life expectancy same as machine.
3. Facilitate good maintenance practice.
4. Compatibility with electrical and mechanical components.
5. Withstand operational hazards.

Efficiency of Operation :

1. Keep system Simple, Safe and Functional.
2. Access to parts need repair or adjustment.
3. Design to keep min operational cost.
4. Design to prevent and remove contamination.

Safety of Operation :

11. Pressure and Temperature ratings.
2. Interlocks for sequential operations
3. Emergency shutdown features.
4. Power failure locks.
5. Operation speed.
6. Environment conditions.

Meet functional requirements :

1. Meet required performance specification.
2. Life expectancy same as machine.
3. Facilitate good maintenance practice.
4. Compatibility with electrical and mechanical components.
5. Withstand operational hazards.

Efficiency of Operation :

- Keep system Simple, Safe and Functional.
2. Access to parts needs repair or adjustment.
 3. Design to keep min operational cost.
 4. Design to prevent and remove contamination.

Linear Circuits :

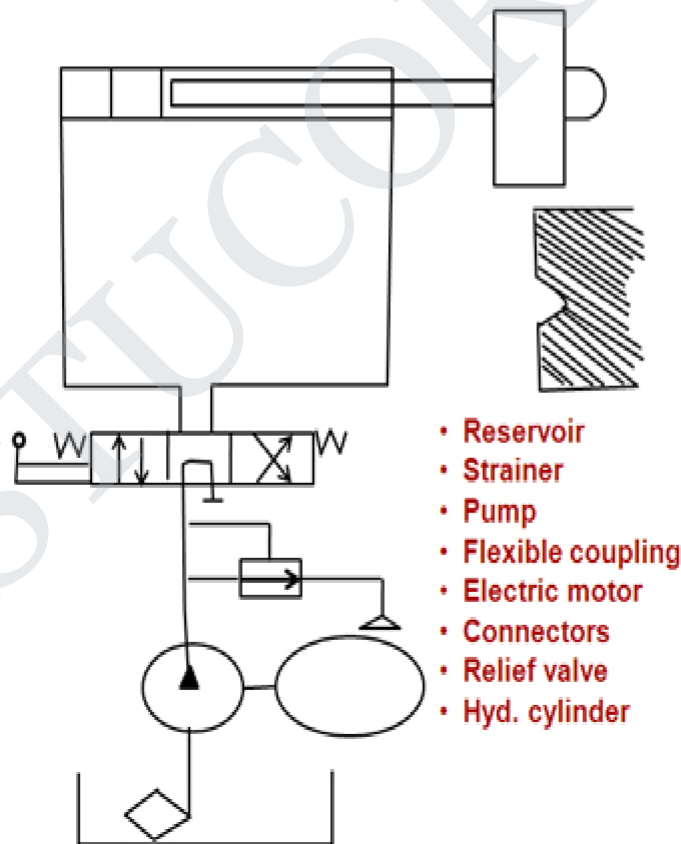
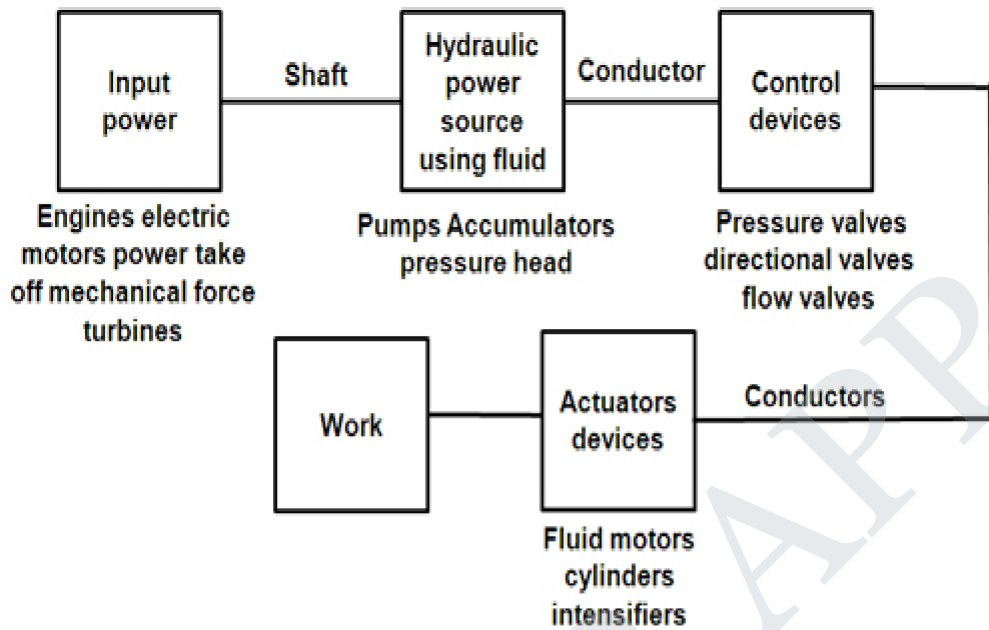

Control of a Single Acting Hydraulic Cylinder :

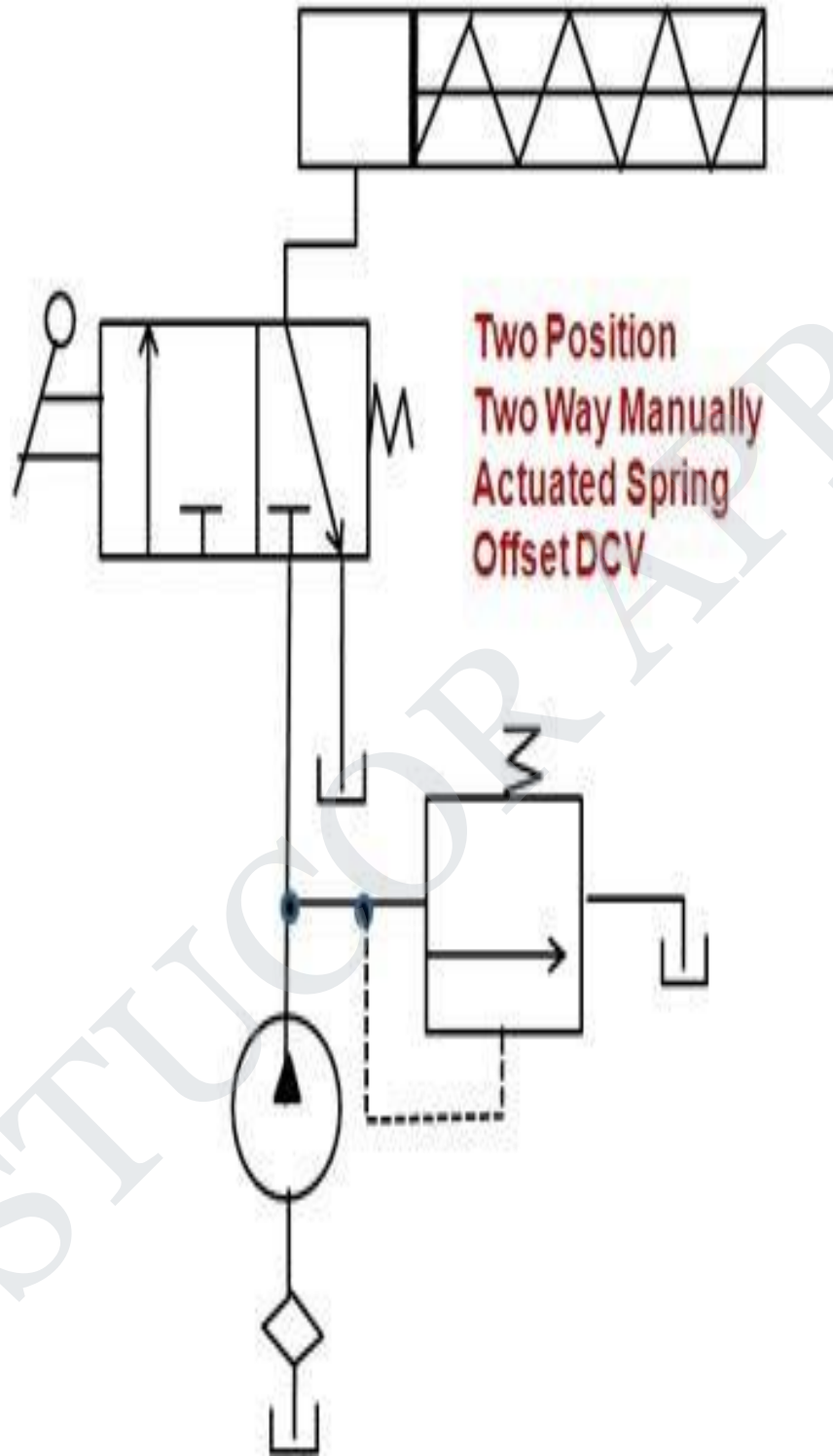

Control of a Double Acting Hydraulic Cylinder :

Three Position Four Way Manually Actuated Spring Centered DCV

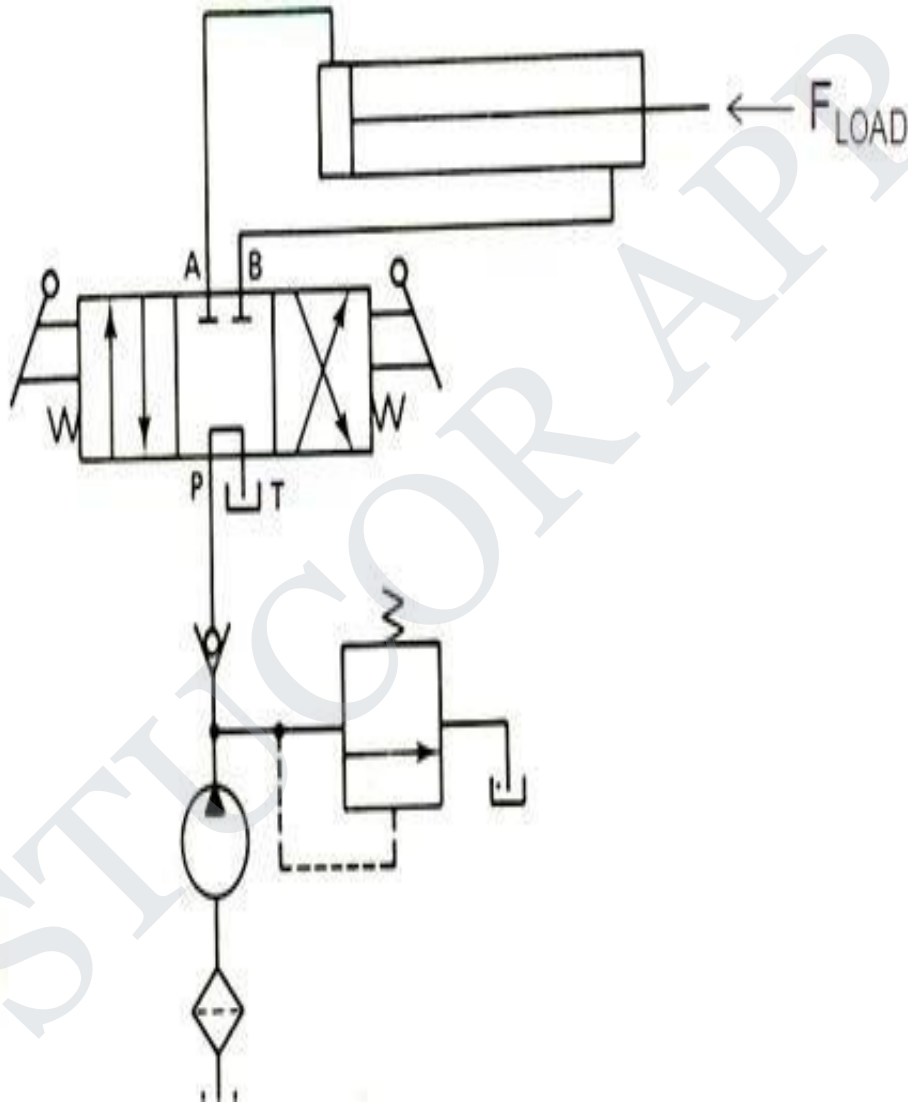

Regenerative Circuit

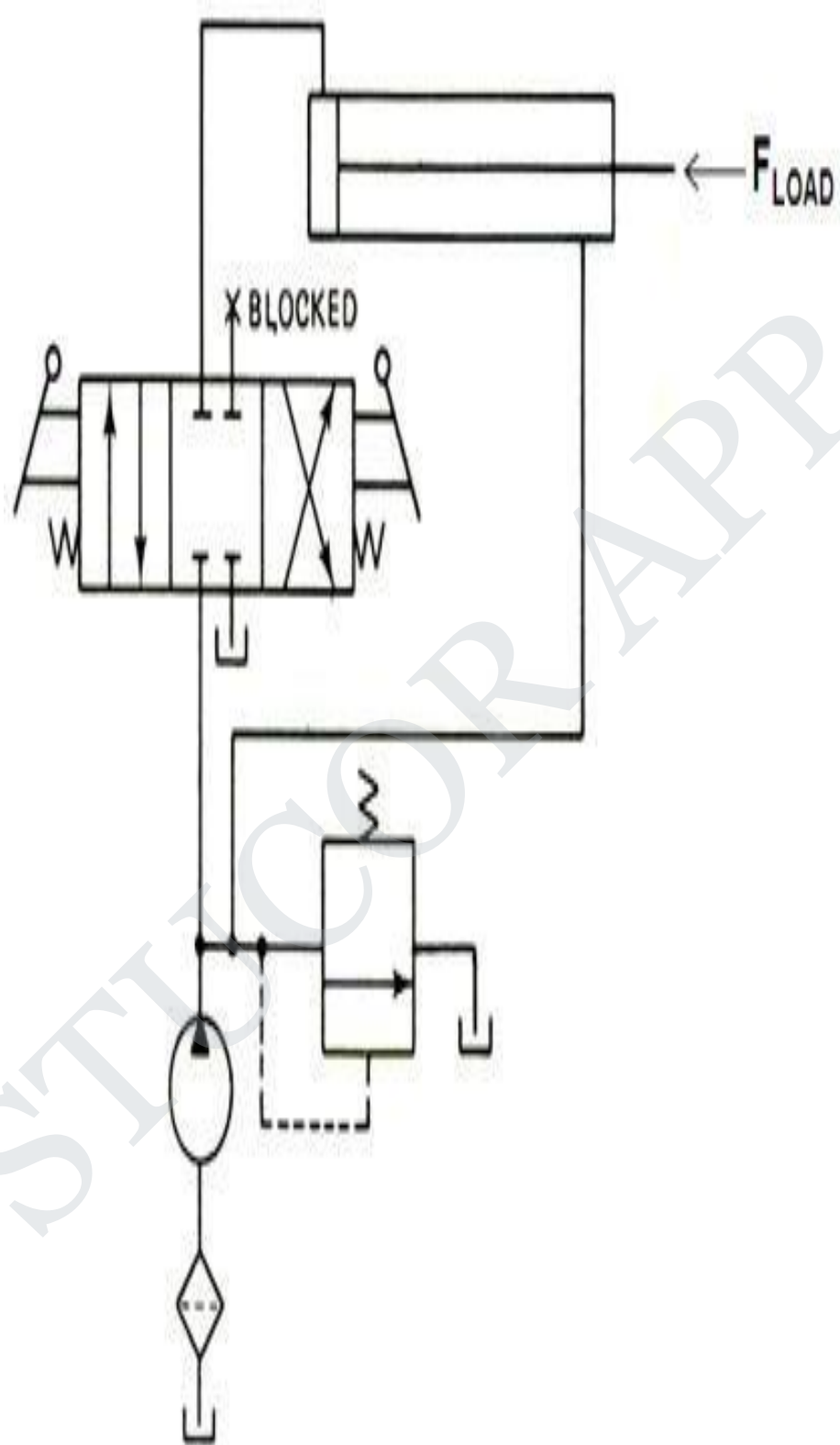

PUMP Unloading circuit

Double Pump Hydraulic System :

- Punch Press.
- Initial Low Pressure high flow rate req.
- When punching operation begins, increased pressure opens unloading valve to unload low pressure pump.
- To keep vertically mounted cylinder in upward position while pump is idling.
- Counterbalance valve is set to open at slightly above the pressure required to hold the piston up.

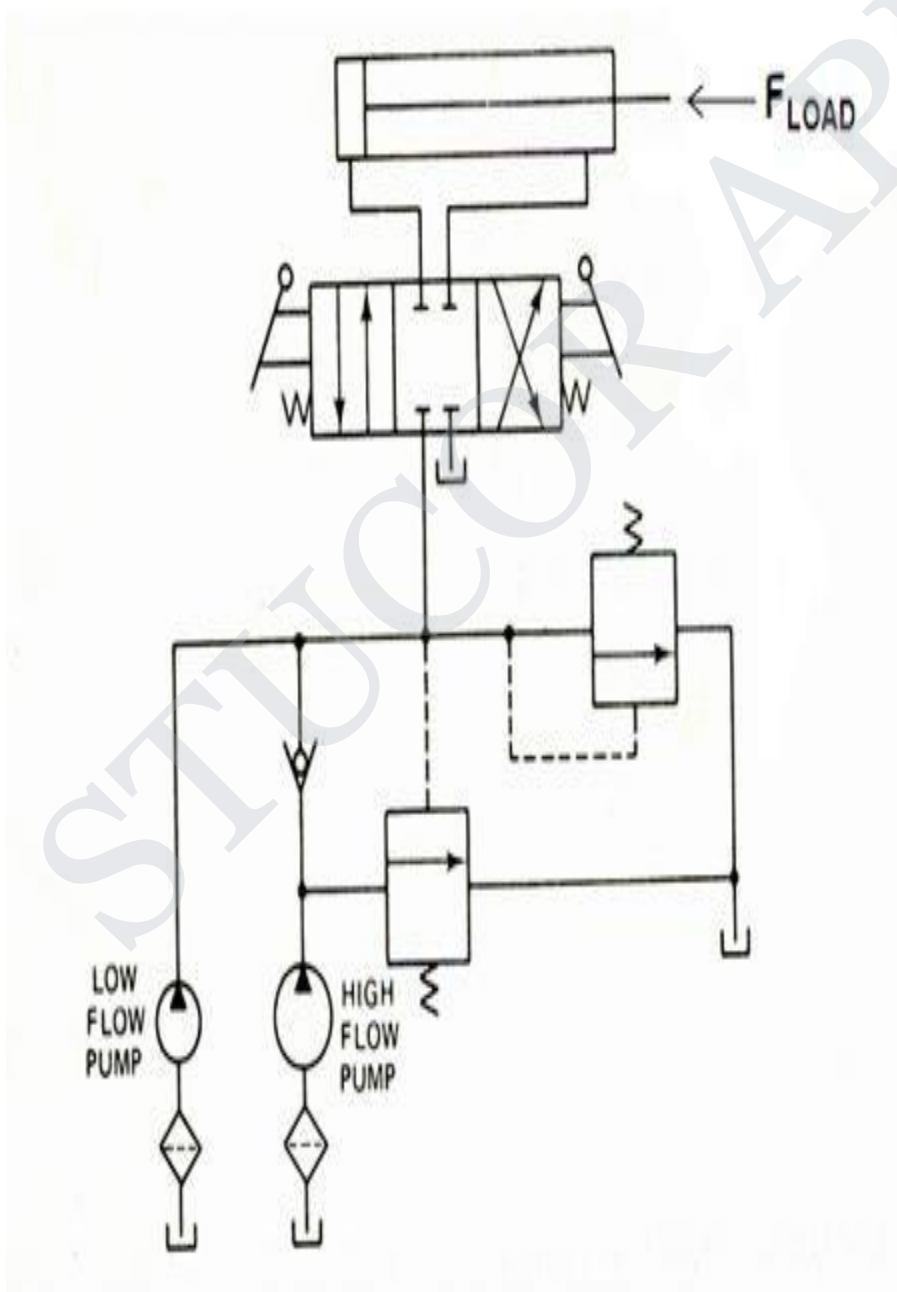

Double Pump Hydraulic System

Hydraulic Cylinder Sequence Circuit :

- **Left Env :** Left Cyl extends completely and then Right Cyl extend.
- **Right Env :** Right Cyl retracts fully and then Left Cyl retracts.

