

DEPARTMENT OF MECHANICAL ENGINEERING

ME8091- AUTOMOBILE ENGINEERING

UNIT NOTES

UNIT-I VEHICLE STRUCTURE AND ENGINES

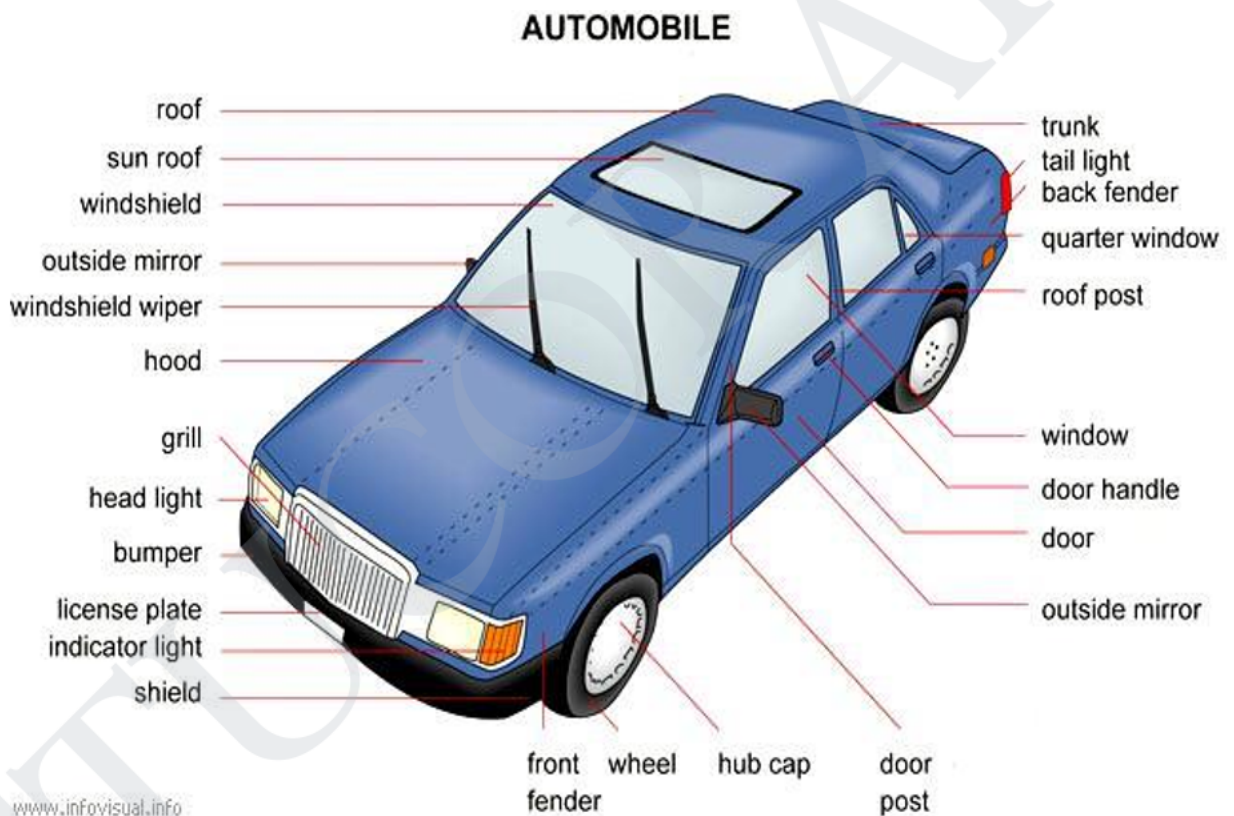

1.1. Introduction of Automobile or Vehicle:

An Automobile is a self propelled vehicle which contains the power source for its propulsion and is used for carrying passengers and goods on the ground, such as car, bus, trucks, etc.,

1.2. Types of Automobile;

The automobiles are classified by the following ways,

1. On the Basis of Load:

- Heavy transport vehicle (HTV) or heavy motor vehicle (HMV),
- Light transport vehicle (LTV), Light motor vehicle (LMV),

2. On the Basis of Wheels :

- Two wheeler vehicle, for example : Scooter, motorcycle, scooty, etc.
- Three wheeler vehicle, for example : Autorickshaw,
- Three wheeler scooter for handicaps and tempo, etc.
- Four wheeler vehicle, for example : Car, jeep, trucks, buses, etc.
- Six wheeler vehicle, for example : Big trucks with two gear axles.

3. On the basis of Fuel Used:

- Petrol vehicle, e.g. motorcycle, scooter, cars, etc.
- Diesel vehicle, e.g. trucks, buses, etc.
- Electric vehicle which use battery to drive.
- Steam vehicle, e.g. an engine which uses steam engine.
- Gas vehicle, e.g. LPG and CNG vehicles, where LPG is liquefied

4. On the basis of body style:

- Sedan Hatchback car.
- Coupe car Station wagon Convertible.
- Van Special purpose vehicle, e.g. ambulance, milk van, etc.

5. On the basis of Transmission:

- Conventional vehicles with manual transmission, e.g. car with 5 gears.
- Semi-automatic
- Automatic : In automatic transmission, gears are not required to be changed manually.

6. On the basis of Drive:

- Left hand drive
- Right hand drive

7. On the basis of Driving Axle

- Front wheel drive
- Rear wheel drive
- All wheel drive

8. Position of Engine:

- Engine in Front - Most of the vehicles have engine in the front. Example : most of the cars,
- Engine in the Rear Side Very few vehicles have engine located in the rear. Example : Nano car.

1.3. Vehicle construction and Components;

The main components of an automobile refer to the following components;

- Frame,
- Chassis,
- Body,
- Power unit,
- Transmission system.

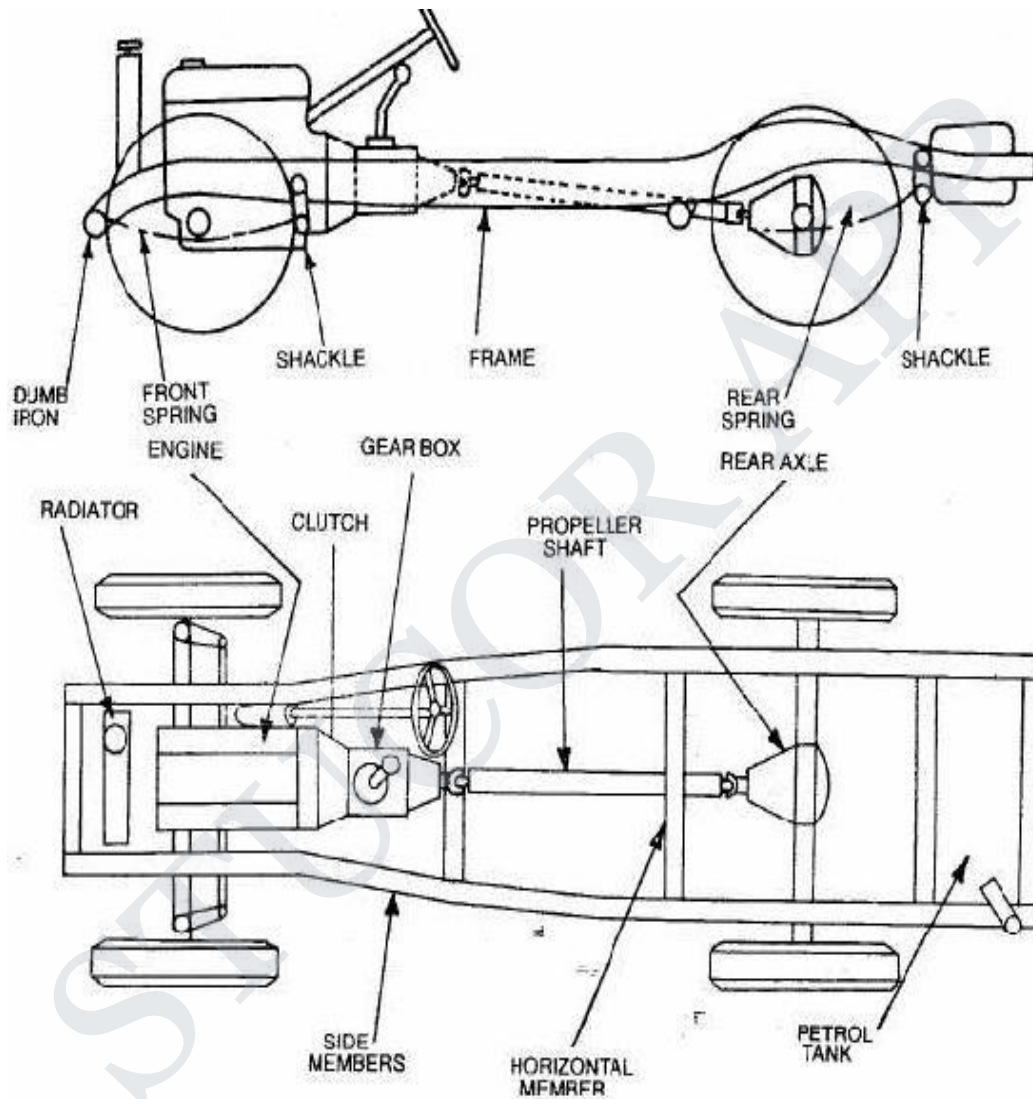

An automobile is made up of mainly two units, these are Chassis and Body.

“Frame” + “Base components” = “Chassis”

“Chassis” + “Body” = “Vehicle”

Frame :

The frame is the skeleton of the vehicle. It servers as a main foundation and base for alignment for the chassis.

Types;

- Conventional frame,
- Semi integral frame;
- Integral or untidiest frame.

Chassis;

If the frame contains the base components its called as chassis. The components are like Engine, radiator, clutch, gearbox, silencer, road wheels, fuel tank, wirings, differential units, etc...

Body:

Body is the superstructure of the vehicle and it is bolted to the chasis.

Types;

- Car,
- Truck,
- Tractor,
- Delivery van,
- Jeep,
- Bus, etc...

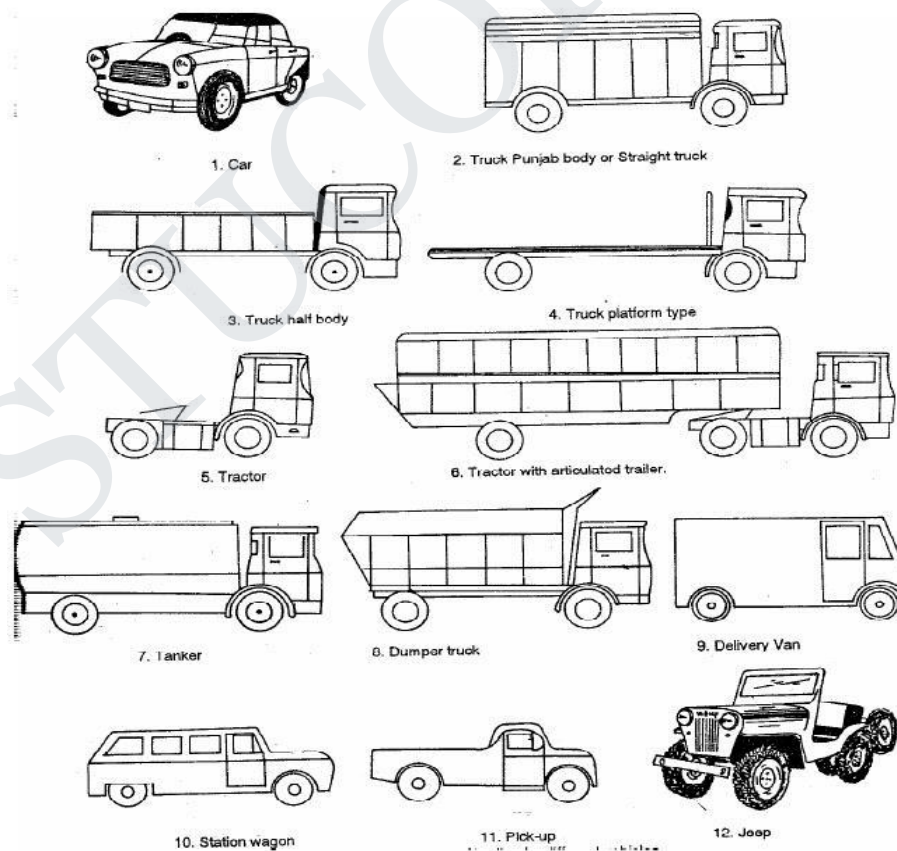

1.4. Resistances to vehicle motion and need for a gearbox

Aerodynamics

Aerodynamics, from Greek $\alpha\eta\rho$ aer (air) + $\delta\upsilon\nu\alpha\mu\iota\kappa\acute{\eta}$ (dynamics), is a branch of dynamics concerned with studying the motion of air, particularly when it interacts with a solid object, such as an airplane wing.

Aerodynamics is a sub-field of fluid dynamics and gas dynamics, and many aspects of aerodynamics theory are common to these fields. The term aerodynamics is often used synonymously with gas dynamics, with the difference being that "gas dynamics" applies to the study of the motion of all gases, not limited to air.

Modern aerodynamics only dates back to the seventeenth century, but aerodynamic forces have been harnessed by humans for thousands of years in sailboats and windmills, and images and stories of flight appear throughout recorded history, such as the Ancient Greek legend of Icarus and Daedalus. Fundamental concepts of continuum, drag, and pressure gradients, appear in the work of Aristotle and Archimedes.

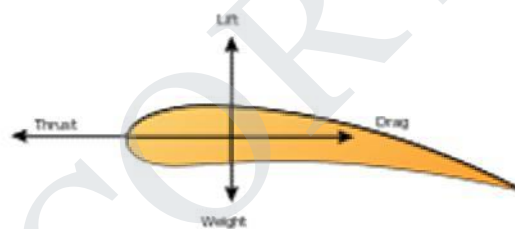

Forces of flight on an airfoil

Fundamental Concept

Understanding the motion of air around an object (often called a flow field) enables the calculation of forces and moments acting on the object. In many aerodynamics problems, the forces of interest are the fundamental forces of flight: lift, drag, thrust, and weight. Of these, lift and drag are aerodynamic forces, i.e. forces due to air flow over a solid body.

Calculation of these quantities is often founded upon the assumption that the flow field behaves as a continuum. Continuum flow fields are characterized by properties such as velocity, pressure, density and temperature, which may be functions of spatial position and time.

These properties may be directly or indirectly measured in aerodynamics experiments, or calculated from equations for the conservation of mass, momentum, and energy in air flows. Density, velocity, and an additional property, viscosity, are used to classify flow fields.

1.5. Components of an Engine;

Even though reciprocating internal combustion engines look quite simple, they are highly complex machines. There are hundreds of components that have to perform their functions satisfactorily to produce output power. There are two types of engines, viz., spark ignition (SI) and compression-ignition (CI) engine. Let us now go through the important engine components and the nomenclature associated with an engine.

Terms connected with i.c. engines;

- **Bore:** The inside diameter of the cylinder is called bore
- **Stroke:** The linear distance along the cylinder axis between two limiting positions is called stroke.
- **Top Dead Center (T.D.C.) :** the top most position of the piston towards cover end side of the cylinder is called T.D.C.
- **Bottom dead Center (B.D.C.) :** The lowest position of the piston towards the crank end side of the cylinder is called B.D.C.
- **Clearance Volume :** The volume contained in the cylinder above the top of the piston , when the piston is at top dead center , is called the clearance volume.
- **Swept Volume:** The volume swept through by the piston in moving between T.D.C. and B.D.C, is called swept volume or piston displacement.
- **Compression Ratio:** It is the ratio of Total cylinder volume to clearance volume

Definition of 'Engine'

An engine is a device, which transforms one form of energy into another form. Normally, most of the engines convert thermal energy into mechanical work and therefore they are called 'heat engines'.

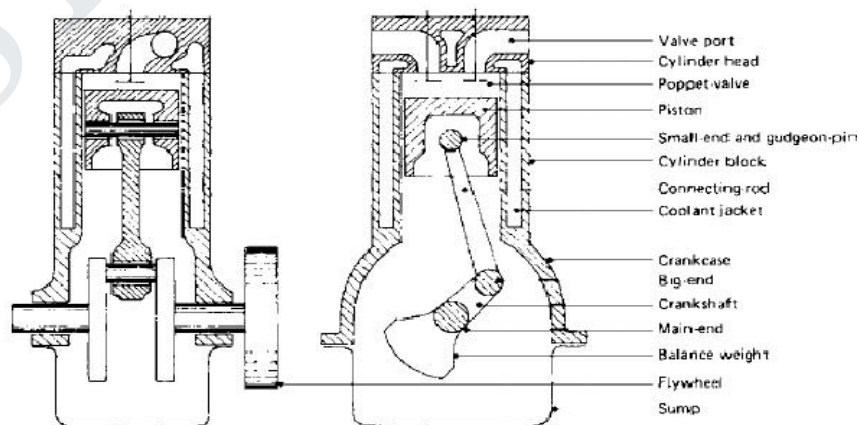

Engine Components

The major components of the engine and their functions are briefly described below.

Cylinder Block:

The cylinder block is the main supporting structure for the various components. The cylinder of a multicylinder engine is cast as a single unit, called cylinder block. The cylinder head is mounted on the cylinder block.

The cylinder head and cylinder block are provided with water jackets in the case of water-cooling with cooling fins in the case of air-cooling. Cylinder head gasket is incorporated between the cylinder block and cylinder head. The cylinder head is held tight to the cylinder block by number of bolts or studs. The bottom portion of the cylinder block is called crankcase. A cover called crankcase, which becomes a sump for lubricating oil is fastened to the bottom of the crankcase. The inner surface of the cylinder block, which is machined and finished accurately to cylindrical shape, is called bore or face.

Cylinder

As the name implies it is a cylindrical vessel or space in which the piston makes a reciprocating motion. The varying volume created in the cylinder during the operation of the engine is filled with the working fluid and subjected to different thermodynamic processes. The cylinder is supported in the cylinder block.

Piston

It is a cylindrical component fitted into the cylinder forming the moving boundary of the combustion system. It fits perfectly (snugly) into the cylinder providing a gas-tight space with the piston rings and the lubricant. It forms the first link in transmitting the gas forces to the output shaft.

Combustion Chamber

The space enclosed in the upper part of the cylinder, by the cylinder head and the piston top during the combustion process, is called the combustion chamber. The combustion of fuel and the consequent release of thermal energy results in the building up of pressure in this part of the cylinder.

Inlet Manifold

The pipe which connects the intake system to the inlet valve of the engine and through which air or air-fuel mixture is drawn into the cylinder is called the inlet manifold.

Gudgeon Pin

It forms the link between the small end of the connecting rod and the piston.

Exhaust Manifold

The pipe that connects the exhaust system to the exhaust valve of the engine and through which the products of combustion escape into the atmosphere is called the exhaust manifold.

Inlet and Exhaust Valves

Valves are commonly mushroom shaped poppet type. They are provided either on the cylinder head or on the side of the cylinder for regulating the charge coming into the cylinder (inlet valve) and for discharging the products of combustion (exhaust valve) from the cylinder.

Connecting Rod

It interconnects the piston and the crankshaft and transmits the gas forces from the piston to the crankshaft. The two ends of the connecting rod are called as small end and the big end. Small end is connected to the piston by gudgeon pin and the big end is connected to the crankshaft by crankpin.

Crankshaft

It converts the reciprocating motion of the piston into useful rotary motion of the output shaft. In the crankshaft of a single cylinder engine there is pair of crank arms and balance weights. The balance weights are provided for static and dynamic balancing of the rotating system. The crankshaft is enclosed in a crankcase.

Piston Rings

Piston rings, fitted into the slots around the piston, provide a tight seal between the piston and the cylinder wall thus preventing leakage of combustion gases

Camshaft

The camshaft and its associated parts control the opening and closing of the two valves. The associated parts are push rods, rocker arms, valve springs and tappets. This shaft also provides the drive to the ignition system. The camshaft is driven by the crankshaft through timing gears.

Cams

These are made as integral parts of the camshaft and are designed in such a way to open the valves at the correct timing and to keep them open for the necessary duration.

Fly Wheel

The net torque imparted to the crankshaft during one complete cycle of operation of the engine fluctuates causing a change in the angular velocity of the shaft. In order to achieve a uniform torque an inertia *mass* in the form of a wheel is attached to the output shaft and this wheel is called the flywheel.

Basic Parts of the Gasoline Engine:

Basic Parts of the Gasoline Engine are listed below;

- Cylinder block
- Piston
- Piston rings
- Piston pin
- Connecting rod
- Crankshaft
- Cylinder head
- Intake valve
- Exhaust valve
- Camshaft
- Timing gears
- Spark plug

Cylinder Block:

Cylinder Block Basic frame of gasoline engine. Contains the cylinder.

Piston:

Piston A sliding plug that harnesses the force of the burning gases in the cylinder.

Piston Rings:

Piston rings seal the compression gases above the piston keep the oil below the piston rings.

Piston Pins:

Piston Pins Also known as the wrist pin, it connects the piston to the small end of the connecting rod. It transfers the force and allows the rod to swing back and forth.

Connecting Rod:

Connecting Rod Connects the piston and piston pin to the crankshaft.

Crankshaft:

Crankshaft Along the the piston pin and connecting rod it converts the up and down motion (reciprocating) of the engine to spinning (rotary) motion.

Flywheel:

Flywheel Carries the inertia when there is no power stroke.

Cylinder Head:

Cylinder Head Forms the top of the combustion chamber. Contains the valves, the passageways for the fuel mixture to move in and out of the engine.

Intake and Exhaust Valves:

Intake and Exhaust Valves Doorway that lets the gases in and out of the engine.

Camshaft:

Camshaft Through the use of an eccentric the cam lobes push the valves open. The valve springs close them.

Timing Gears:

Timing Gears These gears drive the camshaft from the crankshaft.

Why not diesel engines are not preferred in commercial ?:

1. Diesel engines, because they have much higher compression ratios (20:1 for a typical diesel vs. 8:1 for a typical gasoline engine), tend to be heavier than an equivalent gasoline engine.
2. Diesel engines also tend to be more expensive.
3. Diesel engines, because of the weight and compression ratio, tend to have lower maximum RPM ranges than gasoline engines. This makes diesel engines high torque rather than high horsepower, and that tends to make diesel cars slow in terms of acceleration.
4. Diesel engines must be fuel injected, and in the past fuel injection was expensive and less reliable
5. Diesel engines tend to produce more smoke.
6. Diesel engines are harder to start in cold weather, and if they contain glow plugs, diesel engines can require you to wait before starting the engine so the glow plugs can heat up.
7. Diesel engines are much noisier and tend to vibrate.
8. Diesel fuel is less readily available than gasoline

Advantages diesel engines:

The two things working in favor of diesel engines are better fuel economy and longer engine life. Both of these advantages mean that, over the life of the engine, you will tend to save money with a diesel.

However, you also have to take the initial high cost of the engine into account. You have to own and operate a diesel engine for a fairly long time before the fuel economy overcomes the increased purchase price of the engine.

The equation works great in a big diesel tractor-trailer rig that is running 400 miles every day, but it is not nearly so beneficial in a passenger car.

1.6. ENGINE SUPPORT SYSTEMS:

- Cooling system
- Lubrication system
- Fuel and ignition/injection system
- Intake system Exhaust system

1.6.1. Cooling system:

The cooling system removes excess heat to keep the inside of the engine at an efficient temperature.

- Air Cooling
- Liquid Cooling
- Water cooling Coolant.

Water Jackets:

Water Jackets Surrounds the cylinders with water passage. Absorbs heat from the cylinder wall. Pump move water to radiator where heat is exchanged to the air. 66

Coolant Flow:

Coolant flows through the water jackets where it absorbs heat. It then flows through the radiator where heat is transferred to the air passing through. The amount of flow is determined by the water pump. The flow direction is controlled by the thermostat.

Warm Engine:

The thermostat opens when the engine warms up. This allows coolant to circulate through the radiator and the water jackets.

Cold Engine:

When an engine is cold, the thermostat is cold. Coolant flow is through the bypass hose and the water jackets. This allows the engine to warm up evenly.

Coolant :

- Coolant Water (Boiling Point 100° C)
- Glycerin (Boiling Point 290 ° C)
- Ethylene glycol (Boiling Point 197 ° C)
- Antifreeze (methyl alcohol, ethyl alcohol)

Cooling System:

- Water pump is driven by the crankshaft through Timing Belt (Keeps Cam and Crank shafts in time)
- Drive/accessory Belt (Runs alternator, power-steering pump, AC, etc.) Serpentine Belt V-Belt
- Electric fan is mounted on the radiator and is operated by battery power. It is controlled by the thermostat switch.

Need for cooling system

The cooling system has four primary functions. These functions are as follows:

1. Remove excess heat from the engine.
2. Maintain a constant engine operating temperature.
3. Increase the temperature of a cold engine as quickly as possible.
4. Provide a means for heater operation (warming the passenger compartment).

Types of cooling system:

The different Types of cooling system are

1. Air cooling system
2. Liquid cooling system
3. Forced circulation system
4. Pressure cooling system

Air-Cooled System :

The simplest type of cooling is the air-cooled, or direct, method in which the heat is drawn off by moving air in direct contact with the engine. Several fundamental principles of cooling are embodied in this type of engine cooling. The rate of the cooling is dependent upon the following:

1. The area exposed to the cooling medium.
2. The heat conductivity of the metal used & the volume of the metal or its size in cross section .
3. The amount of air flowing over the heated surfaces.
4. The difference in temperature between the exposed metal surfaces and the cooling air.

Liquid-cooled system;

Nearly all multi cylinder engines used in automotive, construction, and material-handling equipment use a liquid-cooled system. Any liquid used in this type of system is called a COOLANT.

A simple liquid-cooled system consists of a radiator, coolant pump, piping, fan, thermostat, and a system of water jackets and passages in the cylinder head and block through which the coolant circulates. Some vehicles are equipped with a coolant distribution tube inside the cooling passages that directs additional coolant to the points where temperatures are highest.

Cooling of the engine parts is accomplished by keeping the coolant circulating and in contact with the metal surfaces to be cooled. The operation of a liquid-cooled system is as follows:

The pump draws the coolant from the bottom of the radiator, forcing the coolant through the water jackets and passages, and ejects it into the upper radiator tank. The coolant then passes through a set of tubes to the bottom of the radiator from which the cooling cycle begins.

The radiator is situated in front of a fan that is driven either by the water pump or an electric motor. The fan ensures airflow through the radiator at times when there is no vehicle motion. The downward flow of coolant through the radiator creates what is known as a thermosiphon action. This simply means that as the coolant is heated in the jackets of the engine, it expands. As it expands, it becomes less dense and therefore lighter. This causes it to flow out of the top outlet of the engine and into the top tank of the radiator. As the coolant is cooled in the radiator, it again becomes more dense and heavier. This causes the coolant to settle to the bottom tank of the radiator.

The heating in the engine and the cooling in the radiator therefore create a natural circulation that aids the water pump. The amount of engine heat that must be removed by the cooling system is much greater than is generally realized. To handle this heat load, it may be necessary for the cooling system in some engine to circulate 4,000 to 10,000 gallons of coolant per hour. The water passages, the size of the pump and radiator, and other details are so designed as to maintain the working parts of the engine at the most efficient temperature within the limitation imposed by the coolant.

Pressure cooling system

Radiator Pressure Cap

The radiator pressure cap is used on nearly all of the modern engines. The radiator cap locks onto the radiator tank filler neck. Rubber or metal seals make the cap-to-neck joint airtight. The functions of the pressure cap are as follows:

1. Seals the top of the radiator tiller neck to prevent leakage.
2. Pressurizes system to raise boiling point of coolant.
3. Relieves excess pressure to protect against system damage.
4. In a closed system, it allows coolant flow into and from the coolant reservoir.

The radiator cap pressure valve consists of a spring-loaded disc that contacts the filler neck. The spring pushes the valve into the neck to form a seal. Under pressure, the boiling point of water increases. Normally water boils at 212°F.

However, for every pound of pressure increase, the boiling point goes up 3°F. Typical radiator cap pressure is 12 to 16 psi. This raises the boiling point of the engine coolant to about 250°F to 260°F. Many surfaces inside the water jackets can be above 212°F. If the engine overheats and the pressure exceeds the cap rating, the pressure valve opens. Excess pressure forces coolant out of the overflow tube and into the reservoir or onto the ground.

This prevents high pressure from rupturing the radiator, gaskets, seals, or hoses. The radiator cap vacuum valve opens to allow reverse flow back into the radiator when the coolant temperature drops after engine operation. It is a smaller valve located in the center, bottom of the cap.

The cooling and contraction of the coolant and air in the system could decrease coolant volume and pressure. Outside atmospheric pressure could then crush inward on the hoses and radiator. Without a cap vacuum or vent valve, the radiator hose and radiator could collapse.

.6.2. Lubrication System:

Parts require lubrications Crankshaft bearing Piston pin Timing gears Valve mechanism Piston ring and cylinder walls Camshaft and bearings.

Purpose of lubrication:

- Reduce friction & wear - by creating a thin film (Clearance) between moving parts
- Seal power - The oil helps form a gastight seal between piston rings and cylinder walls
- Cleaning - Cleans As it circulates through the engine, the oil picks up metal particles and carbon, and brings them back down to the pan.
- Absorb shock - When heavy loads are imposed on the bearings, the oil helps to cushion the load
- Cooling. - Cools Picks up heat when moving through the engine and then drops into the cooler oil pan, giving up some of this heat.

Types Lubrication System:

- Petroil system
- Splash system
- Pressure system
- Dry-sump system

Oil change:

- Every 5000Km for four wheeler , Every 2000 Km in two wheeler Ignoring regular oil change intervals will shorten engine life and performance.

All internal combustion engines are equipped with an internal lubricating system. Without lubrication, an engine quickly overheats and its working parts seize due to excessive friction. All moving parts must be adequately lubricated to assure maximum wear and long engine life.

Purpose of Lubrication;

The functions of an engine lubrication system are as follows: Reduces friction and wear between moving parts. Helps transfer heat and cool engine parts. Cleans the inside of the engine by removing contaminants (metal, dirt, plastic, rubber, and other particles).

Absorbs shocks between moving parts to quiet engine operation and increase engine life. The properties of engine oil and the design of modern engines allow the lubrication system to accomplish these functions.

Types of Lubrication Systems;

Now that you are familiar with the lubricating system components, you are ready to study the different systems that circulate oil through the engine. The systems used to circulate oil are known as splash, combination splash force feed, force feed, and full force-feed.

Splash Systems

The splash system is no longer used in automotive engines. It is widely used in small four-cycle engines for lawn mowers, outboard marine operation, and so on. In the splash lubricating system, oil is splashed up from the oil pan or oil trays in the lower part of the crankcase.

The oil is thrown upward as droplets or fine mist and provides adequate lubrication to valve mechanisms, piston pins, cylinder walls, and piston rings. In the engine, dippers on the connecting-rod bearing caps enter the oil pan with each crankshaft revolution to produce the oil splash.

A passage is drilled in each connecting rod from the dipper to the bearing to ensure lubrication. This system is too uncertain for automotive applications. One reason is that the level of oil in the crankcase will vary greatly the amount of lubrication received by the engine. A high level results in excess lubrication and oil consumption and a slightly low level results in inadequate lubrication and failure of the engine.

Combination Splash and Force Feed

In a combination splash and force feed, oil is delivered to some parts by means of splashing and other parts through oil passages under pressure from the oil pump. The oil from the pump enters the oil galleries. From the oil galleries, it flows to the main bearings and camshaft bearings.

The main bearings have oil-feed holes or grooves that feed oil into drilled passages in the crankshaft. The oil flows through these passages to the connecting rod bearings. From there, on some engines, it flows through holes drilled in the connecting rods to the piston-pin bearings. Cylinder walls are lubricated by splashing oil thrown off from the connecting-rod bearings.

Some engines use small troughs under each connecting rod that are kept full by small nozzles which deliver oil under pressure from the oil pump. These oil nozzles deliver an increasingly heavy stream as speed increases. At very high speeds these oil streams are powerful enough to strike the dippers directly. This causes a much heavier splash so that adequate lubrication of the pistons and the connecting-rod bearings is provided at higher speeds. If a combination system is used on an overhead valve engine, the upper valve train is lubricated by pressure from the pump.

Force Feed

A somewhat more complete pressurization of lubrication is achieved in the force-feed lubrication system. Oil is forced by the oil pump from the crankcase to the main bearings and the camshaft bearings. Unlike the combination system the connecting-rod bearings are also fed oil under pressure from the pump. Oil passages are drilled in the crankshaft to lead oil to the connecting-rod bearings.

The passages deliver oil from the main bearing journals to the rod bearing journals. In some engines, these openings are holes that line up once for every crankshaft revolution. In other engines, there are annular grooves in the main bearings through which oil can feed constantly into the hole in the crankshaft. The pressurized oil that lubricates the connecting-rod bearings goes on to lubricate the pistons and walls by squirting out through strategically drilled holes. This lubrication system is used in virtually all engines that are equipped with semi-floating piston pins.

Full Force Feed

In a full force-feed lubrication system, the main bearings, rod bearings, camshaft bearings, and the complete valve mechanism are lubricated by oil under pressure. In addition, the full force-feed lubrication system provides lubrication under pressure to the pistons and the piston pins.

This is accomplished by holes drilled the length of the connecting rod, creating an oil passage from the connecting rod bearing to the piston pin bearing. This passage not only feeds the piston pin bearings but also provides lubrication for the pistons and cylinder walls. This system is used in virtually all engines that are equipped with full-floating piston pins.

Four-stroke Spark-ignition Engine

In a four-stroke engine, the cycle of operations is completed in four strokes of the piston or two revolutions of the crankshaft. During the four strokes, there are five events to be completed, viz, suction, compression, combustion, expansion and exhaust. Each stroke consists of 180° of crankshaft rotation and hence a four-stroke cycle is completed through 720° of crank rotation. The cycle of operation for an ideal four-stroke SI engine consists of the following four strokes:

- i. Suction or intake stroke;
- ii. Compression stroke;
- iii. Expansion or power stroke and
- iv. Exhaust stroke.

Working principle of a Four Stroke SI Engine

i. Suction or Intake Stroke: Suction stroke starts when the piston is at the top dead centre and about to move downwards. The inlet valve is open at this time and the exhaust valve is closed. Due to the suction created by the motion of the piston towards the bottom dead centre, the charge consisting of fuel-air mixture is drawn into the cylinder. When the piston reaches the bottom dead centre the suction stroke ends and the inlet valve closes.

ii. Compression Stroke: The charge taken into the cylinder during the suction stroke is compressed by the return stroke of the piston. During this stroke both inlet and exhaust valves are in closed position. The mixture that fills the entire cylinder volume is now compressed into the

clearance volume. At the end of the compression stroke the mixture is ignited with the help of a spark plug located on the cylinder head. In ideal engines it is assumed that burning takes place instantaneously when the piston is at the top dead centre and hence the burning process can be approximated as heat addition at constant volume.

During the burning process the chemical energy of the fuel is converted into heat energy producing a temperature rise of about 2000 °C. The pressure at the end of the combustion process is considerably increased due to the heat release from the fuel.

iii. Exhaust Stroke: At the end of the expansion stroke the exhaust valve opens and the inlet valve remains closed. The pressure falls to atmospheric level a part of the burnt gases escape. The piston starts moving from the bottom dead centre to top dead centre and sweeps the burnt gases out from the cylinder almost at atmospheric pressure.

The exhaust valve closes when the piston reaches T.D.C. at the end of the exhaust stroke and some residual gases trapped in the clearance volume remain in the cylinder. Residual gases mix with the fresh charge coming in during the following cycle, forming its working fluid.

Each cylinder of a four stroke engine completes the above four operations in two engine revolutions, one revolution of the crankshaft occurs during the suction and compression strokes and the second revolution during the power and exhaust strokes. Thus for one complete cycle there's only one power stroke while the crankshaft turns by two revolutions.

Consumption of lubricating oil is high in two-stroke engines due to higher temperature. A detailed comparison of two-stroke and four-stroke engines is given in the Table below

STUCOR APP

UNIT-II

ENGINE AUXILIARY SYSTEMS

The fuel feed system for the Spark ignition engines and Compression ignition engines are clearly discussed below.

2.1. Fuel Injection system for SI engines;

2.1.1. Carburetion

Spark-ignition engines normally use volatile liquid fuels. Preparation of fuel-air mixture is done outside the engine cylinder and formation of a homogeneous mixture is normally not completed in the inlet manifold. Fuel droplets, which remain in suspension, continue to evaporate and mix with air even during suction and compression processes. The process of mixture preparation is extremely important for spark-ignition engines. The purpose of carburetion is to provide a combustible mixture of fuel and air in the required quantity and quality for efficient operation of the engine under all conditions.

Definition of Carburetion;

The process of formation of a combustible fuel-air mixture by mixing the proper amount of fuel with air before admission to engine cylinder is called carburetion and the device which does this job is called a carburetor.

Definition of Carburetor;

The carburetor is a device used for atomizing and vaporizing the fuel and mixing it with the air in varying proportions to suit the changing operating conditions of vehicle engines.

Factors Affecting Carburetion

Of the various factors, the process of carburetion is influenced by

- i. The engine speed
- ii. The vaporization characteristics of the fuel
- iii. The temperature of the incoming air and
- iv. The design of the carburetor

Principle of Carburetion

Both air and gasoline are drawn through the carburetor and into the engine cylinders by the suction created by the downward movement of the piston. This suction is due to an increase in the volume of the cylinder and a consequent decrease in the gas pressure in this chamber.

It is the difference in pressure between the atmosphere and cylinder that causes the air to flow into the chamber. In the carburetor, air passing into the combustion chamber picks up discharged from a tube. This tube has a fine orifice called carburetor jet that is exposed to the air path.

The rate at which fuel is discharged into the air depends on the pressure difference or pressure head between the float chamber and the throat of the venturi and on the area of the outlet of the tube. In order that the fuel drawn from the nozzle may be thoroughly atomized, the suction effect must be strong and the nozzle outlet comparatively small. In order to produce a strong suction, the pipe in the carburetor carrying air to the engine is made to have a restriction. At this restriction called throat due to increase in velocity of flow, a suction effect is created. The restriction is made in the form of a venturi to minimize throttling losses.

The end of the fuel jet is located at the venturi or throat of the carburetor. The geometry of venturi tube is as shown in Fig.16.6. It has a narrower path at the center so that the flow area through which the air must pass is considerably reduced. As the same amount of air must pass through every point in the tube, its velocity will be greatest at the narrowest point. The smaller the area, the greater will be the velocity of the air, and thereby the suction is proportionately increased

As mentioned earlier, the opening of the fuel discharge jet is usually loped where the suction is maximum. Normally, this is just below the narrowest section of the venturi tube. The spray of gasoline from the nozzle and the air entering through the venturi tube are mixed together in this region and a combustible mixture is formed which passes through the intake manifold into the cylinders. Most of the fuel gets atomized and simultaneously a small part will be vaporized. Increased air velocity at the throat of the venturi helps the rate of evaporation of fuel. The difficulty of obtaining a mixture of sufficiently high fuel vapour-air ratio for efficient starting of the engine and for uniform fuel-air ratio indifferent cylinders (in case of multi cylinder engine) cannot be fully met by the increased air velocity alone at the venturi throat.

2.1.2. The Simple Carburetor

Carburetors are highly complex. Let us first understand the working principle of a simple or elementary carburetor that provides an air fuel mixture for cruising or normal range at a single speed. Later, other mechanisms to provide for the various special requirements like starting, idling, variable load and speed operation and acceleration will be included. Figure 3. shows the details of a simple carburetor.

The simple carburetor mainly consists of a float chamber, fuel discharge nozzle and a metering orifice, a venturi, a throttle valve and a choke. The float and a needle valve system maintain a constant level of gasoline in the float chamber. If the amount of fuel in the float chamber falls below the designed level, the float goes down, thereby opening the fuel supply valve and admitting fuel. When the designed level has been reached, the float closes the fuel supply valve thus stopping additional fuel flow from the supply system. Float chamber is vented either to the atmosphere or to the upstream side of the venturi. During suction stroke air is drawn through the venturi.

As already described, venturi is a tube of decreasing cross-section with a minimum area at the throat, Venturi tube is also known as the choke tube and is so shaped that it offers minimum resistance to the air flow. As the air passes through the venturi the velocity increases reaching a maximum at the venturi throat. Correspondingly, the pressure decreases reaching a minimum. From the float chamber, the fuel is fed to a discharge jet, the tip of which is located in the throat of the venturi. Because of the differential pressure between the float chamber and the throat of the venturi, known as carburetor depression, fuel is discharged into the air stream.

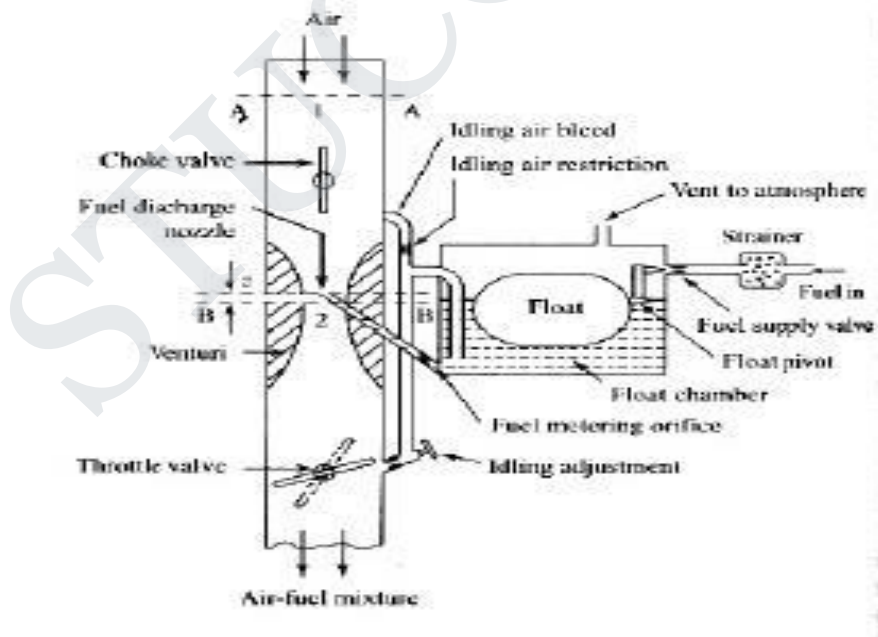

Figure: 3 The Simple Carburetor

The fuel discharge is affected by the size of the discharge jet and it is chosen to give the required air-fuel ratio. The pressure at the throat at the fully open throttle condition lies between 4 to 5 cm of Hg, below atmospheric and seldom exceeds 8 cm Hg below atmospheric. To avoid overflow of fuel through the jet, the level of the liquid in the float chamber is maintained at a level slightly below the tip of the discharge jet. This is called the tip of the nozzle. The difference in the height between the top of the nozzle and the float chamber level is marked h in Fig.3.

The gasoline engine is quantity governed, which means that when power output is to be varied at a particular speed, the amount of charge delivered to the cylinder is varied. This is achieved by means of a throttle valve usually of the butterfly type that is situated after the venturi tube.

As the throttle is closed less air flows through the venturi tube and less is the quantity of air-fuel mixture delivered to the cylinder and hence power output is reduced. As the throttle is opened, more air flows through the choke tube resulting in increased quantity of mixture being delivered to the engine. This increases the engine power output. A simple carburetor of the type described above suffers from a fundamental drawback in that it provides the required A/F ratio only at one throttle position.

At the other throttle positions the mixture is either leaner or richer depending on whether the throttle is opened less or more. As the throttle opening is varied, the air flow varies and creates a certain pressure differential between the float chamber and the venturi throat. The same pressure differential regulates the flow of fuel through the nozzle. Therefore, the velocity of flow of air and fuel vary in a similar manner.

The Choke and the Throttle

When the vehicle is kept stationary for a long period during cool winter seasons, may be overnight, starting becomes more difficult. As already explained, at low cranking speeds and intake temperatures a very rich mixture is required to initiate combustion. Some times air-fuel ratio as rich as 9:1 is required. The main reason is that very large fraction of the fuel may remain as liquid suspended in air even in the cylinder. For initiating combustion, fuel-vapour and air in the form of mixture at a ratio that can sustain combustion is required.

It may be noted that at very low temperature vapour fraction of the fuel is also very small and this forms combustible mixture to initiate combustion. Hence, a very rich mixture must be supplied. The most popular method of providing such mixture is by the use of choke valve. This is simple butterfly valve located between the entrance to the carburetor and the venturi throat as shown in Fig.3.

When the choke is partly closed, large pressure drop occurs at the venturi throat that would normally result from the quantity of air passing through the venturi throat. The very large depression at the throat inducts large amount of fuel from the main nozzle and provides a very rich mixture so that the ratio of the evaporated fuel to air in the cylinder is within the combustible limits. Sometimes, the choke valves are spring loaded to ensure that large carburetor depression and excessive choking does not persist after the engine has started, and reached a desired speed.

This choke can be made to operate automatically by means of a thermostat so that the choke is closed when engine is cold and goes out of operation when engine warms up after starting. The speed and the output of an engine is controlled by the use of the throttle valve, which is located on the downstream side of the venturi.

The more the throttle is closed the greater is the obstruction to the flow of the mixture placed in the passage and the less is the quantity of mixture delivered to the cylinders. The decreased quantity of mixture gives a less powerful impulse to the pistons and the output of the engine is reduced accordingly. As the throttle is opened, the output of the engine increases. Opening the throttle usually increases the speed of the engine. But this is not always the case as the load on the engine is also a factor. For example, opening the throttle when the motor vehicle is starting to climb a hill may or may not increase the vehicle speed, depending upon the steepness of the hill and the extent of throttle opening. In short, the throttle is simply a means to regulate the output of the engine by varying the quantity of charge going into the cylinder.

Compensating Devices

An automobile on road has to run on different loads and speeds. The road conditions play a vital role. Especially on city roads, one may be able to operate the vehicle between 25 to 60% of the throttle only. During such conditions the carburetor must be able to supply nearly constant air-fuel ratio mixture that is economical (16:1). However, the tendency of a simple carburetor is to progressively richen the mixture as the throttle starts opening.

The main metering system alone will not be sufficient to take care of the needs of the engine. Therefore, certain compensating devices are usually added in the carburetor along with the main metering system so as to supply a mixture with the required air-fuel ratio. A number of compensating devices are in use. The important ones are

- i. Air-bleed jet
- ii. Compensating jet
- iii. Emulsion tube
- iv. Back suction control mechanism
- v. Auxiliary air valve
- vi. Auxiliary air port

As already mentioned, in modern carburetors automatic compensating devices are provided to maintain the desired mixture proportions at the higher speeds. The type of compensation mechanism used determines the metering system of the carburetor. The principle of operation of various compensating devices are discussed briefly in the following sections.

Air-bleed jet

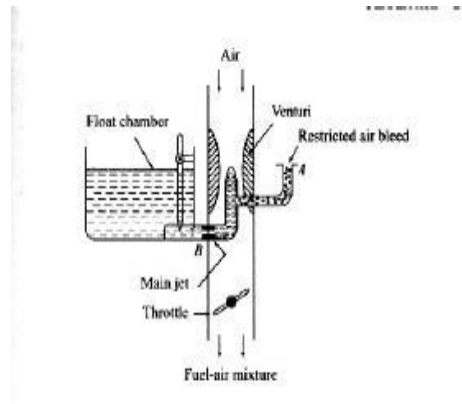

Figure: 4 Air bleed principle in a typical carburetor

Figure 4. illustrates a principle of an air-bleed system in atypical modern downdraught carburetor. As could be seen it contains an air-bleed into the main nozzle. An orifice restricts the flow of air through this bleed and therefore it is called restricted air-bleed jet that is very popular. When the engine is not operating the main jet and the air bleed jet will be filled with fuel. When the engine starts, initially the fuel starts coming through the main as well as the air bleed jet (A). As the engine picks up, only air starts coming through the air bleed and mixes with fuel at B making a air fuel emulsion.

Thus the fluid stream that has become an emulsion of air and liquid has negligible viscosity and surface tension. Thus the flow rate of fuel is augmented and more fuel is sucked at low suction. ‘By proper design of hole size at B compatible with the entry hole at A, it is possible to maintain a fairly uniform mixture ratio for the entire power range of the operation of an engine. If the fuel flow nozzle of the air-bleed system is placed in the centre of the venturi, both the air-bleed nozzle and the venturi are subjected to same engine suction resulting approximately same fuel-air mixture for the entire power range of operation.

Compensating Jet

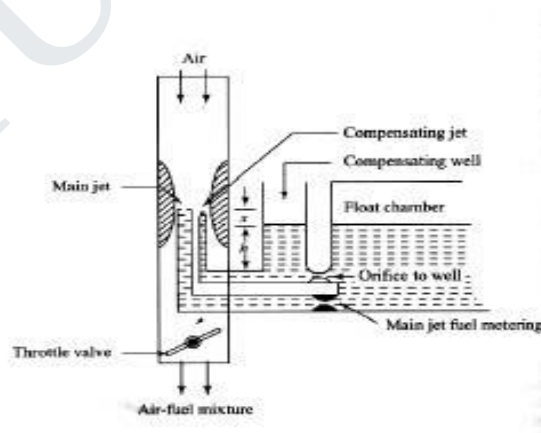

Figure: 5 Compensating Jet device

The principle of compensating jet device is to make the mixture leaner as the throttle opens progressively. In this method, as can be seen from Fig.5 in addition to the main jet, a compensating jet is incorporated. The compensating jet is connected to the compensation well. The compensating well is also vented to atmosphere like the main float chamber.

The compensating well is supplied with fuel from the main float chamber through a restricting orifice. With the increase in airflow rate, there is decrease of fuel level in the compensating well, with the result that fuel supply through the compensating jet decreases. The compensating jet thus progressively makes the mixture leaner as the main jet progressively makes the mixture richer. The main jet curve and the compensating jet curve are more or less reciprocals of each other.

Emulsion Tube

The mixture correction is attempted by air bleeding in modern carburetor. In one such arrangement as shown in Fig.6, the main metering jet is kept at a level of about 25 mm below the fuel level in the float chamber. Therefore, it is also called submerged jet. The jet is located at the bottom of a well. The sides of the well have holes. As can be seen from the figure these holes are in communication with the atmosphere. In the beginning the level of petrol in the float chamber and the well is the same.

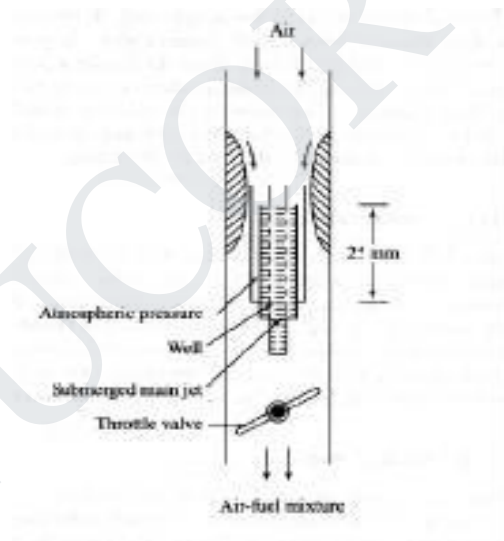

Figure: 6 Emulsion Tube

When the throttle is opened the pressure at the venturi throat decreases and petrol is drawn into the air stream. This results in progressively uncovering the holes in the central tube leading to increasing air-fuel ratios or decreasing richness of mixture when all holes have been uncovered. Normal flow takes place from the main jet. The air is drawn through these holes in the well, and the fuel is emulsified and the pressure differential across the column of fuel is not as high as that in simple carburetor.

Acceleration Pump System

Acceleration is a transient phenomenon. In order to accelerate the vehicle and consequently its engine, the mixture required is very rich and the richness of the mixture has to be obtained quickly and very rapidly. In automobile engines situations arise when it is necessary to accelerate the vehicle. This requires an increased output from the engine in a very short time.

If the throttle is suddenly opened there is a corresponding increase in the air flow. However, because of the inertia of the liquid fuel, the fuel flow does not increase in proportion to the increase in air flow. This results in a temporary lean mixture calling the engine to misfire and a temporary reduction in power output.

To prevent this condition, all modern carburetors are equipped with an accelerating system. Figure 7. illustrates simplified sketch of one such device. The pump comprises of a spring loaded plunger that takes care of the situation with the rapid opening of the throttle valve. The plunger moves into the cylinder and forces an additional jet of fuel at the venturi throat.

When the throttle is partly open, the spring sets the plunger back. There is also an arrangement which ensures that fuel in the pump cylinder is not forced through the jet when valve is slowly opened or leaks past the plunger or some holes into the float chamber.

Mechanical linkage system, in some carburetor, is substituted by an arrangement where by the pump plunger is held up by manifold vacuum. When this vacuum is decreased by rapid opening of the throttle, a spring forces the plunger down pumping the fuel through the jet.

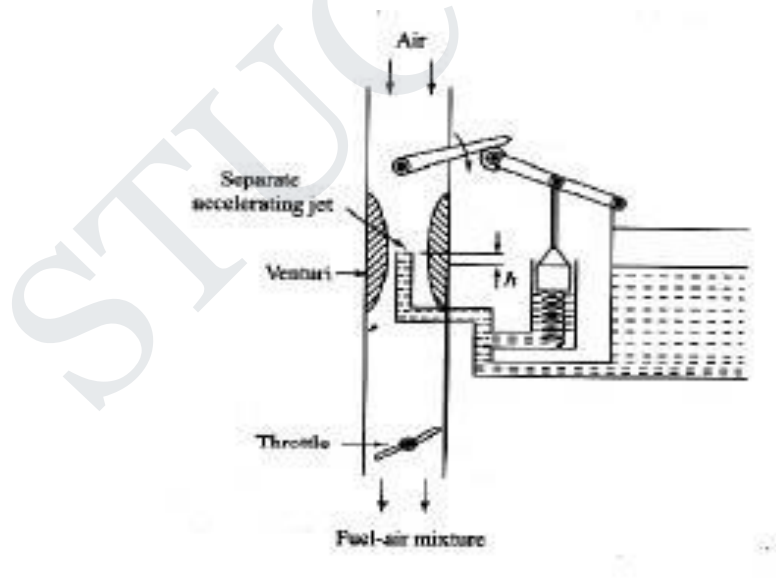

Figure: 7 Acceleration pump system

2.1.3. Types of Carburetors

There are three general types of carburetors depending on the direction of flow of air. The first is the up draught type shown in Fig.8(a) in which the air enters at the bottom and leaves at the top so that the direction of its flow is upwards. The disadvantage of the up draught carburetor is that it must lift the sprayed fuel droplet by air friction. Hence, it must be designed for relatively small mixing tube and throat so that even at low engine speeds the air velocity is sufficient to lift and carry the fuel particles along. Otherwise, the fuel droplets tend to separate out providing only a lean mixture to the engine. On the other hand, the mixing tube is finite and small then it cannot supply mixture to the engine at a sufficiently rapid rate at high speeds.

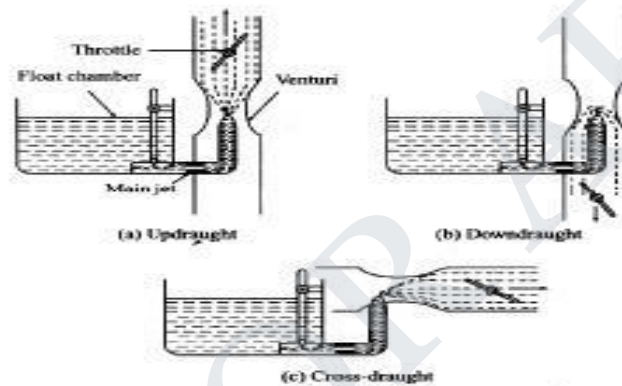

Figure: 8 Types of Carburetors

In order to overcome this drawback the downdraught carburetor [Fig.8 (b)] is adopted. It is placed at a level higher than the inlet manifold and in which the air and mixture generally follow a downward course. Here the fuel does not have to be lifted by air friction as in the up draught carburetors but move into the cylinders by gravity even if the air velocity is low. Hence, the mixing tube and throat can be made large which makes high engine speeds and high specific outputs possible.

Constant Choke Carburetor:

In the constant choke carburetor, the air and fuel flow areas are always maintained to be constant. But the pressure difference or depression, which causes the flow of fuel and air, is being varied as per the demand on the engine. Solex and Zenith carburetors belong to this class.

Constant Vacuum Carburetor:

In the constant vacuum carburetor, (sometimes called variable choke carburetor) air and fuel flow areas are being varied as per the demand on the engine, while the vacuum is maintained to be always same. The S.U. and Carter carburetors belong to this class.

Multiple Venturi Carburetor:

Multiple venturi system uses double or triple venturi. The boost venturi is located concentrically within the main venturi. The discharge edge of the boost venturi is located at the throat of the main venturi. The boost venturi is positioned upstream of the throat of the larger main venturi. Only a fraction of the total air flows through the boost venturi. Now the pressure at the boost venturi exit equals the pressure at the main venturi throat. The fuel nozzle is located at the throat of the boost venturi.

2.2. Fuel Injection system for C I engines;

Fuel system components FUEL INJECTION PUMP - Fuel injection pump sucks fuel from the tank, pressurizes the fuel to approx. 600 - 1000 bar and sends it to the injectors. Inline FIP - Has separate pumping chambers for each cylinder Rotary FIP (Distributor pump) - Has one pumping chamber and the pump distributes to each cylinder as per sequence- firing order INJECTORS - Inject the high pressure fuel in to each cylinder. FUEL FILTER - Filters the fuel from dirt & sediments, since the Fuel injection pump requires clean fuel.

Injection system In the C.I. engine the fuel is injected into the combustion chamber, it has to mix thoroughly with the air, ignite and burn all at the same time. To insure this happens, two types of combustion chamber have been developed. Direct Injection Indirect Injection

2.2.1. Electronic Diesel Control

Electronic Diesel Control is a diesel engine fuel injection control system for the precise metering and delivery of fuel into the combustion chamber of modern diesel engines used in trucks and cars.



EDC injection inline pump

The mechanical fly-weight governors of inline and distributor diesel fuel injection pumps used to control fuel delivery under a variety of engine loads and conditions could no longer deal with the ever increasing demands for efficiency, emission control, power and fuel consumption.

These demands are now primarily fulfilled by the Electronic Control, the system which provides greater ability for precise measuring, data processing, operating environment flexibility and analysis to ensure efficient diesel engine operation. The EDC replaces the mechanical control governor with an electro-magnetic control device.

2.2.2. Components in Electronically controlled Diesel Supply;

The EDC is divided into these main groups of components.

- Electronic sensors for registering operating conditions and changes. A wide array of physical inputs is converted into electrical signal outputs.
- Actuators or solenoids which convert the control unit's electrical output signal into mechanical control movement.
- ECM (Electronic Control Module) or Engine ECU (Electronic Control Unit) with microprocessors which process information from various sensors in accordance with programmed software and outputs required electrical signals into actuators and solenoids.



EDC accelerator pedal assembly

1. Electronic sensors;

- Injection pump speed sensor - monitors pump rotational speed
- Fuel rack position sensor - monitors pump fuel rack position
- Charge air pressure sensor - measures pressure side of the turbocharger
- Fuel pressure sensor
- Air cleaner vacuum pressure sensor
- Engine position sensor
- Temperature sensors - measure various operating temperatures

- Intake temperature
- Charge air temperature
- Coolant temperature
- Fuel temperature
- Exhaust temperature (Pyrometer)
- Ambient temperature
- Vehicle speed sensor - monitors vehicle speed
- Brake pedal sensor - operates with cruise control, exhaust brake, idle control
- Clutch pedal sensor - operates with cruise control, exhaust brake, idle control
- Accelerator pedal sensor.

2. Electronic Control Unit;



ECU control unit

The ECU collects and processes signals from various on-board sensors. An ECU electronic module contains microprocessors, memory units, analog to digital converters and output interface units. Depending upon the parameters, a number of different maps can be stored in the on board memory.

This allows the ECU to be tailored to the specific engine and vehicle requirements, depending on the application. The operating software of the ECU can be adapted for a wide variety of engines and vehicles without the necessity of hardware modification.

The ECU is usually located in the cab or in certain cases, in a suitable position in the engine bay where additional environmental conditions might require cooling of the ECU as well as a requirement for better dust, heat and vibrations insulation .

3. Actuators and Solenoids

Electro-magnetic actuators are usually located on the fuel pump to transfer electrical signals into mechanical action in this case fuel rack actuator and or fuel stop solenoid which means that depending on requests from control unit full fuel or no fuel quantity.

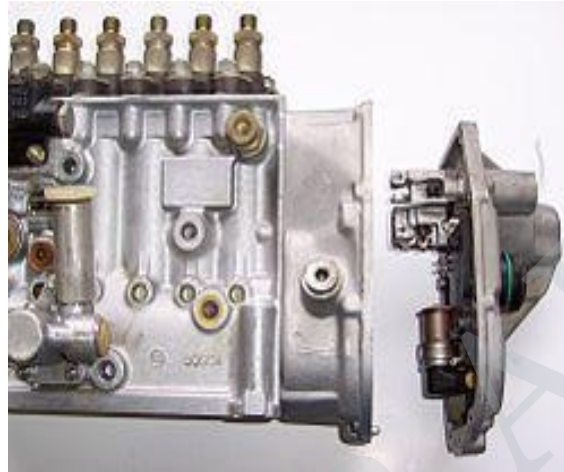

EDC pump actuator

- Injectors
- Boost-pressure actuator
- Intake-duct switchoff
- Throttle-valve actuator
- Exhaust-gas recirculation actuator
- Auxiliary heating
- A/C compressor
- Radiator fan
- Electronic shutoff valve
- Rail-pressure control valve
- Diagnosis lamp

Working Principle;

The injection of fuel or the quantity of injected fuel has a decisive influence on engine starting, idling, power and emissions. The engine ECU is programmed ("mapped") with relevant data to where the fuel rack position has an equivalent signal for the amount of fuel being injected.

The driver requests the torque or engine speed requirements via accelerator pedal potentiometer thereby sending a signal to the engine ECU which then, depending on its *mapping* and data collected from various sensors, calculates in real time the quantity of injected fuel required, thus altering the fuel rack to the required position. The driver can also input additional commands such as idle speed increase to compensate e.g. for PTO operation which can be either variably set or has a preset speed which can be recalled.

The road speed function can be used to evaluate vehicle speed and possibly activate a speed limiter (Heavy Vehicles), or maintain or restore a set speed (cruise control). Further functions can include exhaust brake operation which, when activated, will result in the fuel pump rack position being set to zero delivery or idle. The engine ECU can also interface with various other vehicle systems e.g. traction control and carries out self monitoring duties and self diagnostic functions to keep the system working at an optimal level. To ensure the safe operation in case of failure, the limp home mode functions are also integrated into the system, for e.g. should the pump speed sensor fail the ECU can use an alternator speed signal function for engine RPMs counter as a backup signal.

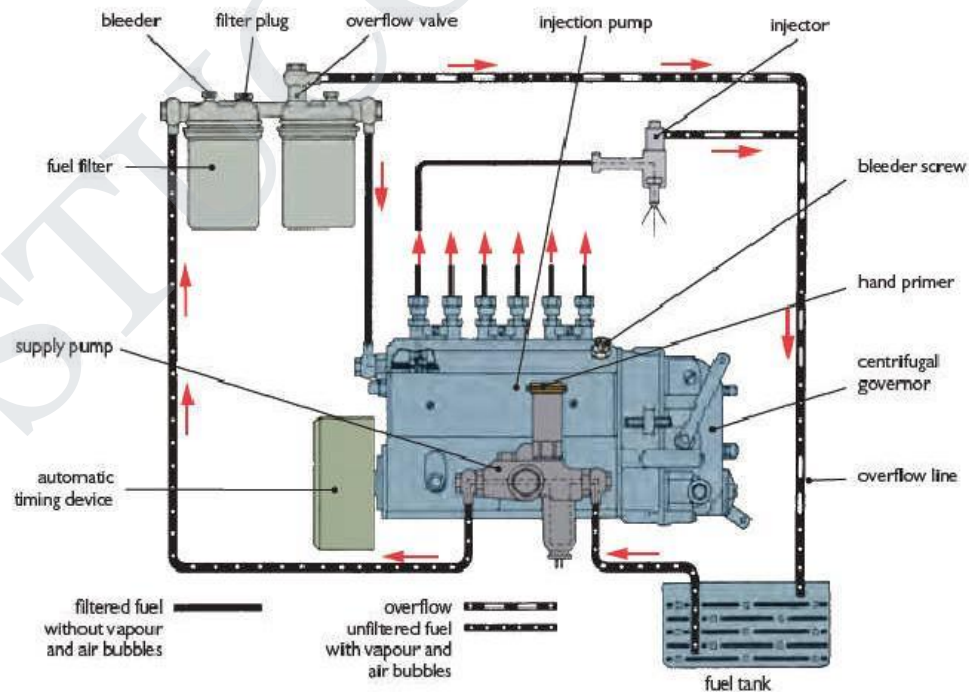

2.2.3. Fuel Injector:

Fuel injection is a system for admitting fuel into an internal combustion engine. It has become the primary fuel delivery system used in automotive engines, having replaced carburetors during the 1980s and 1990s. A variety of injection systems have existed since the earliest usage of the internal combustion engine.

The primary difference between carburetors and fuel injection is that fuel injection atomizes the fuel by forcibly pumping it through a small nozzle under high pressure, while a carburetor relies on suction created by intake air accelerated through a Venturi tube to draw the fuel into the airstream.

Modern fuel injection systems are designed specifically for the type of fuel being used. Some systems are designed for multiple grades of fuel (using sensors to adapt the tuning for the fuel currently used). Most fuel injection systems are for gasoline or diesel applications.

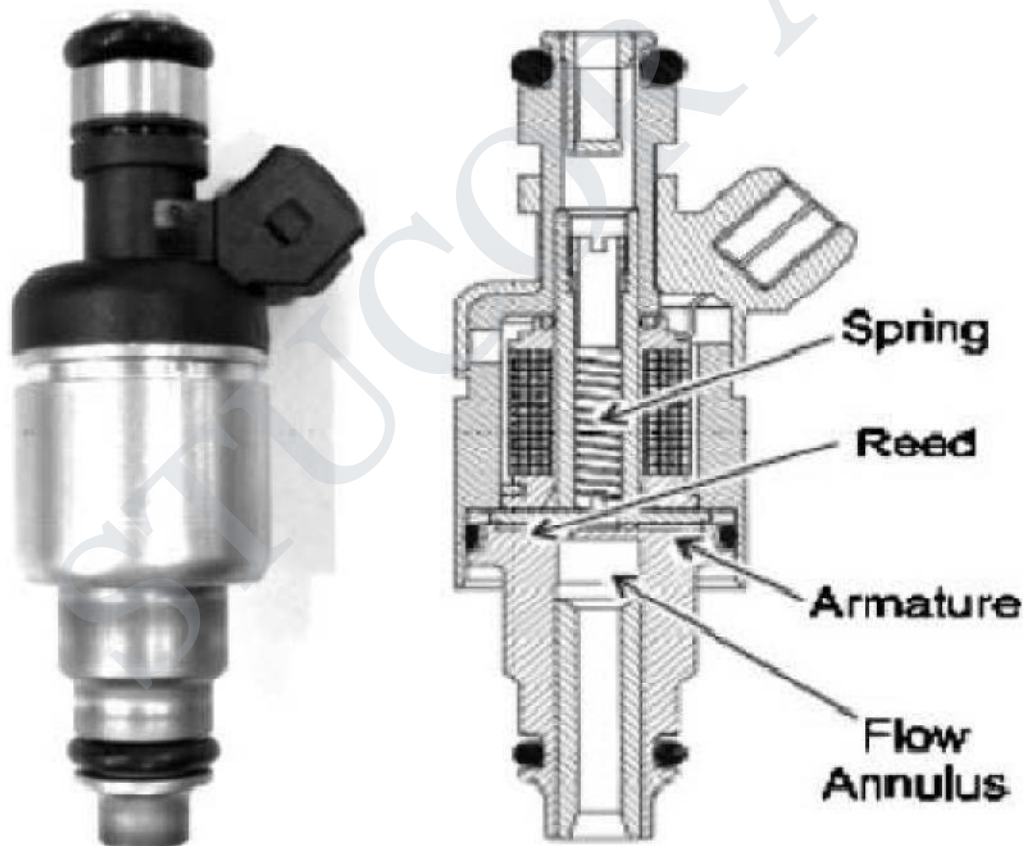

2.3. Introduction of Ignition System;

- For petrol engine - Battery ignition system , Magneto ignition system Injection system
- For diesel engine - Fuel supply system.

Battery ignition system:

Battery ignition system has the following elements

- Primary Ignition Circuit(low voltage)
- Battery
- Ignition switch
- Primary windings of coil
- Contact breaker
- capacitor
- Secondary Ignition Circuit (high voltage)
- Secondary windings of coil
- Distributor cap and rotor (if the vehicle is so equipped)
- Spark plug wires &
- Spark plugs

IGNITION SYSTEM – Magneto System Ignition Switch Distribution Contact Breaker Coil
Magneto Condenser Power Generation Spark Generation Magneto Unit Rotor Arm

IGNITION SYSTEM – Dynamo/Alternator System Dynamo/ Alternator Distributor Contact
Breaker Coil Ignition Switch Secondary Windings Primary Windings Condenser Battery

Ignition Switch Coil Packs IGNITION SYSTEM – Electronic Systems Control Unit Timing Sensor
Timing Disc Engine Speed Sensing Unit Alternator Battery

In all spark ignition engines which work on the Gasoline either 2-Stroke or 4-Stroke cycle principle and utilize a carburetor or fuel injection system, the combustion of the air-fuel mixture is initiated by an electric spark.

The term ‘Spark Ignition’ means that a brief electric arc is produced between the electrodes of a spark plug, the energy for which is derived from an external power source. In most cases this power source is the vehicle battery, which is constantly being supplemented by the alternate while the vehicle is mobile.

A different method of ignition is employed in diesel engines. This is called ‘compression ignition’ and relies on the fact that when air compressed, its temperature rises. In diesel engines, compression ratio of between 16:1 and 25:1 are common, and at the end of a compression the temperature of the trapped air is sufficiently high to ignite the diesel fuel that is sprayed into the cylinder at the appropriate time.

The functions of ignition system

The functions of the coil ignition systems in general use on motor vehicle may be divided into three areas. These are:

- Production of the high voltage necessary to produce a spark at the plug gap.
- Distribute the spark to all the cylinders at proper time based on the firing order.
- Varying the timing of the spark depending on the various operating conditions of the engine like cranking time, varying speed and load, so that the best performance is obtained from the engine under all operating conditions.

Mechanism of Ignition

It must be remembered that vehicle battery voltages are usually 12 volt or 24 volt and this value is too low to produce a heavy spark at the plug gap in a cylinder under compression. For this reason one of the major functions of the battery ignition system is to raise the battery voltage to the required level and then apply it to spark plugs.

This process is correctly initiated in the primary circuit and completed in the secondary winding of the ignition coil. Depending on the type of engine and the conditions existing in the cylinders, a voltage of between 5,000 to 20,000 volts is required and this is called the **ionizing voltage** or **firing voltage**.

This firing voltage forces the electrons to jump between the electrodes of the spark plug in the gap to produce the required spark. The electric spark has sufficient heat energy to ignite the air-fuel mixture which later continues to burn itself.

The conventional coil ignition system

Inductive ignition systems: that uses an **ignition coil** to perform the step up transformer action and to increase the electrical voltage. The ignition coils of the inductive ignition systems operate on the principle of electromagnetic induction (EMI) irrespective of whether it is triggered by contact breakers or by electronic triggering units.

Note:

As a reminder of the principle of EMI, a voltage will be induced into a coil whenever the following factors are present:

- (a) a magnetic field
- (b) a set of conductors
- (c) a relative movement between the magnetic field and conductors.

The factors affecting the operation of the Ignition system.

The factors that determine the value of the voltages induced into the ignition coil windings during the ignition cycle are:

- (a) The strength of the magnetic field.
The stronger the magnetic field produced in the coil primary winding, the greater the possibility of producing a high secondary voltage.
- (b) The number of conductors on the secondary winding being cut by the magnetic field. This is important when considering the voltages produced in both coil windings during the ignition cycle.
- (c) The speed of relative movement between the magnetic field and the conductors. The faster the magnetic field can be made to cut the conductors, the higher will be the value of voltage induced into the coil windings.

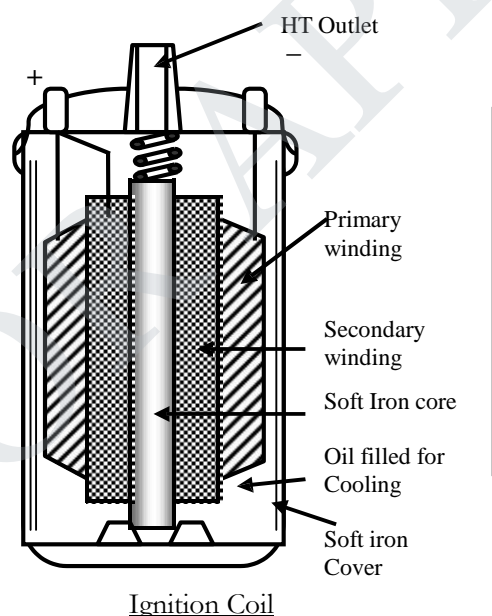

Construction of the Ignition coil

The source of the high voltage pulses of current produced in the inductive ignition system is in the ignition coil. The coil stores the energy in the magnetic field around the primary winding and at the required instant of ignition, transforms it into a pulse of high voltage current in the secondary winding. From here it is delivered to the correct spark plug via the high tension (HT) cables. This 'Inductive storage device' may vary in design between certain manufacturers, but in general the most common construction is as shown in figure below.

This coil contains a rod shaped, laminated soft iron core at its centre, and the soft iron cover surrounds both primary and secondary windings. Both of these soft iron components are used to intensify and maximize the effect of the primary magnetic field and thus, the energy stored. The iron core must be laminated to minimize the effects of eddy currents that are produced during operation and so keep to a minimum the heat developed. The outer soft iron cover is slotted to allow circulation of the oil filling which is used for cooling purposes.

Around the laminated core, the secondary winding is wound. This consists of many turns of very fine insulated copper wire (generally in the vicinity of 20,000 turns). One end of this winding is connected to the HT outlet of the coil via the laminated iron core which it used as the pick-up point for this connection. The other end is connected to the positive (+) low tension primary terminal.

Over the top of the secondary winding the primary winding is wound with the insulation. The primary winding consisting of a few hundred turns of relatively heavy insulated copper wire. The ends of the primary winding are connected to the two low tension, or primary terminals. A reason for placing the primary winding over the secondary is that it is in this coil, which carries the full primary circuit current (approximately 2 ampere in standard systems), the secondary winding generates the heat and by placing it thus, the cooling oil is given ready access to it.

A ceramic insulator at the base of the coil supports the core and winding and at the top is a plastic-type insulator which provides a location point for the high-tension and primary terminals. This top insulator is sealed into the outer case to prevent the loss of coolant oil or the energy of moisture.

Operation of an Ignition coil

Electromagnetic induction is the effect of creating the voltage in a conductor by means of relative movement between the conductor and a magnetic field. In the ignition coil the conductors remain stationary and the magnetic field is moved across them. To develop these necessary conditions, the first requirement in the ignition coil is the production of a magnetic field. This is the function of the primary winding.

When the ignition switch is closed, the primary winding of the coil is connected to the positive terminal of the vehicle battery. Now, if the primary circuit is completed through the contact breaker points a current will flow in the circuit, creating a magnetic field in the coil around the soft iron core. This magnetic field grows outwards from the core until it has reached maximum value and the core is fully magnetized and ceases to grow further.

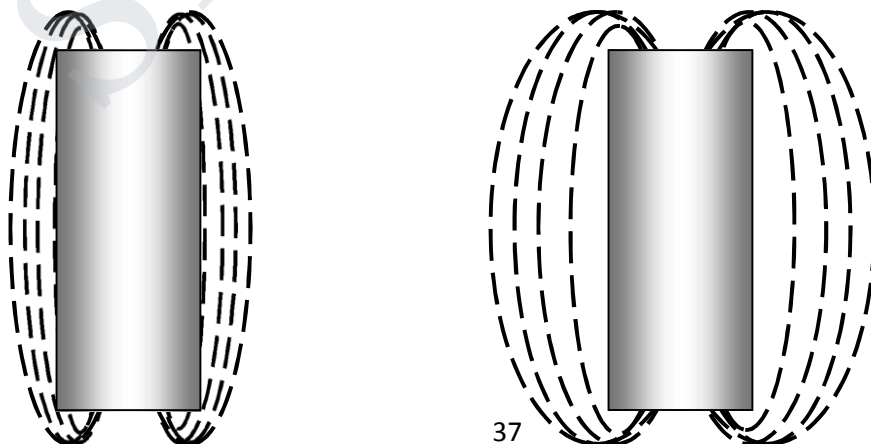

Growing Magnetic field

To provide the very high voltage necessary to create a spark across the plug gap, the secondary winding has a very large number of turns. NOTE: The ratio of the number of secondary turns to the number of primary turns is very large – approximately 100:1. The effect of this high ration is to produce a very high voltage in the secondary winding when the magnetic field is collapsed rapidly across it as the contact breaker points are opened.

To understand the operation of the ignition coil, it is necessary to have the knowledge of the effect of winding insulated wire into the form of a coil and then passing a current through it. In earlier chapters of this course, an explanation was given of how a magnetic field forms around a wire when current flows through it.

Construction

The construction of a capacitor is quite simple. It is made of two strips of metallised paper, separated by a thin dielectric (insulator), generally of waxed paper or plastic, both rolled tightly together and fitted into a metal container. An insulated flexible lead is attached to one of the metallised plates and brought out for connection to the insulated side of the contacts. The other metallised plate is attached to the metal container which has facilities for connecting it to a good earth either inside or outside the distributor, thus effectively connecting the capacitor across, or in parallel, with the points.

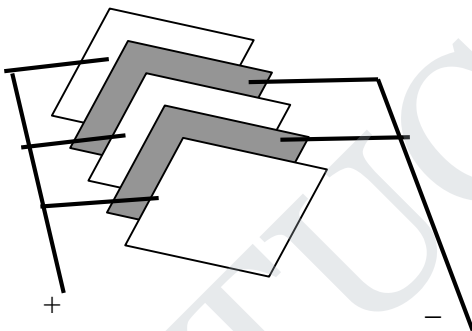

As a general statement it can be said that a capacitor is a device which has the ability to store an electrical charge. When a capacitor is 'charged', each plate will hold an equal but opposite charge. That is the plate connected to the negative side of the circuit will acquire a negative charge, and the plate connected to the positive side of the circuit, a positive charge. Once these opposite charges are stored on the plates, they will attract each other through the separating dielectric, and thus tend to prevent the charge escaping or leaking away.

NOTE: The loss of electrical charge from a capacitor is termed the capacitor's leakage. Among the tests applied to a capacitor is a test for leakage, which must be below a certain rate of loss.

Removing the charge from a capacitor is called discharging it. This is accomplished by connecting a conductor across its plates. The excess electrons are attracted from the negatively charged plate to the positively charged plate. The electron flow continues until such time as both charges equalize, i.e. there is no potential difference between the plates.

The factors affecting the capacity of a capacitor:

- (a) The area of the plates holding the charges and the number of plates used.
- (b) The distance the plates are separated, i.e. the thinner the dielectric, the greater the attractive force between the charges, and therefore the higher the capacity.
- (c) The type of dielectric, e.g. plastic, mica, paper, air, etc.

Unit of Capacitor

The amount of charge a capacitor can hold is termed its capacitance (symbol C) which is measured in a unit called the farad (symbol F). Since the farad is a large quantity and it is difficult to have such a big capacitor in real time, the capacitors are generally measured by micro farad (Symbol μF)

Automotive capacitors are in the vicinity of 0.20 to 0.30 microfarads (one microfarad = 10^{-6} farads, or 1 millionth of a farad).

The operation of a capacitor in an ignition circuit is relatively simple, but tends to appear complex because of the number of events, or changes, that occur simultaneously. The following explanation presents these changes as a logical, sequential set of events.

CIRCUIT OF THE IGNITION CIRCUIT

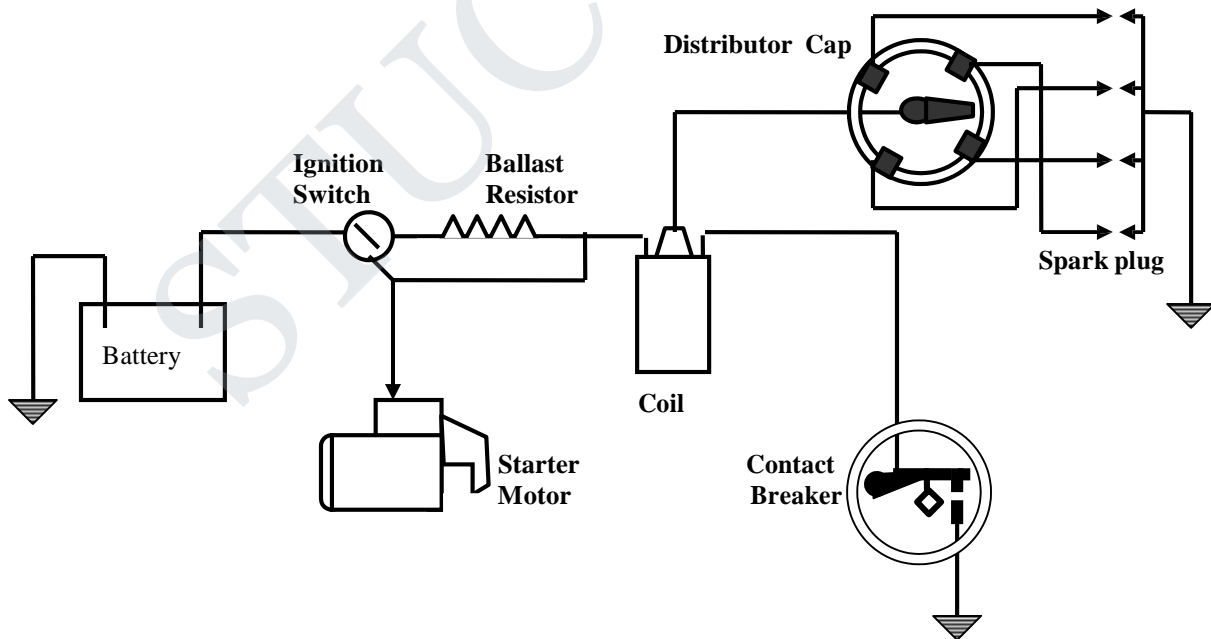

A simple circuit shown above can illustrate the position of the major components of an ignition system. **With the ignition switch 'on'**: when the breaker contacts initially close, a current commences to flow in the primary circuit and the magnetic field builds up relatively slowly, due to the self induced voltage that is developed at this time

During this 'closed circuit period' of the ignition cycle, the capacitor is in parallel with the breaker contacts which are closed at this time. As the distributor shaft continues its rotation the cam lobe lift the breaker gently to open the contacts.

It takes a certain number of degrees of distributor shaft rotation and therefore a measurable period of time for this to occur.

When the contacts are open and instantly a resistance is presented to the primary circuit because of this contact gap. The primary current is interrupted and the magnetic field is starting to collapse. The current produced by the self induced voltage has to enter the plates of the capacitor. Since the high resistance will be induced across the contacts due to their separation and it will naturally take the low resistance path.

Capacitor function

When the contacts gap is slowly widening and the self induced voltage is rapidly rising towards the 200-300 volt level. The capacitor is rapidly charging up. As the capacitor reaches the fully charged state, the contacts have opened to such a degree that even this high voltage cannot jump the gap and so the primary circuit currents comes to an 'instant halt'.

This sudden stopping of the primary current, produced by the action of the capacitor, gives an extremely fast collapse of the magnetic field. The mutually induced voltage, generated in the secondary winding at this instant will be very high. Since the secondary winding has about 100 times as many turns as the primary winding, the secondary voltage will be about 100 times higher than the primary voltage (200 to 300 volts).

The secondary voltage at this instant is fed out through the HT circuit to the correct spark plug where it ionizes the plug gap and forms a spark which ignites the air-fuel mixture. For the period of time of spark duration the capacitor remains fully charged. After the energy of the secondary circuit has been expended in the HT spark, the capacitor discharges back through the battery, ignition switch and coil primary to the opposite plate of the capacitor, thus recharging it in the reverse direction. The capacitor then discharges back again to recharge itself in the original direction – but at a lower value. It continues this oscillating cycle of charge and discharge until all of the stored energy is dissipated across the resistance of the primary circuit. The distributor cam continues its rotation, the points close again and the whole cycle is repeated.

2.4. CRDI - Common rail fuel injection system:

Common rail direct fuel injection is a modern variant of direct fuel injection system for petrol and diesel engines. On diesel engines, it features a high-pressure (over 1,000 bar or 100 MPa or 15,000 psi) fuel rail feeding individual solenoid valves, as opposed to low-pressure fuel pump feeding unit injectors (or pump nozzles). Third-generation common rail diesels now feature piezoelectric injectors for increased precision, with fuel pressures up to 3,000 bar (300 MPa; 44,000 psi). In gasoline engines, it is used in gasoline direct injection engine technology.

Working Principle;

Solenoid or piezoelectric valves make possible fine electronic control over the fuel injection time and quantity, and the higher pressure that the common rail technology makes available provides better fuel atomisation. To lower engine noise, the engine's electronic control unit can inject a small amount of diesel just before the main injection event ("pilot" injection), thus reducing its explosiveness and vibration, as well as optimising injection timing and quantity for variations in fuel quality, cold starting and so on. Some advanced common rail fuel systems perform as many as five injections per stroke. Common rail engines require a very short (< 10 seconds) to no heating-up time^l depending on ambient temperature, and produce lower engine noise and emissions than older systems. Diesel engines have historically used various forms of fuel injection. Two common types include the unit injection system and the distributor/inline pump systems (See diesel engine and unit injector for more information). While these older systems provided accurate fuel quantity and injection timing control, they were limited by several factors:

- They were cam driven, and injection pressure was proportional to engine speed. This typically meant that the highest injection pressure could only be achieved at the highest engine speed and the maximum achievable injection pressure decreased as engine speed decreased. This relationship is true with all pumps, even those used on common rail systems. With unit or distributor systems, the injection pressure is tied to the instantaneous pressure of a single pumping event with no accumulator, and thus the relationship is more prominent and troublesome.
- They were limited in the number and timing of injection events that could be commanded during a single combustion event. While multiple injection events are possible with these older systems, it is much more difficult and costly to achieve.
- For the typical distributor/inline system, the start of injection occurred at a pre-determined pressure (often referred to as: pop pressure) and ended at a pre-determined pressure. This characteristic resulted from "dummy" injectors in the cylinder head which opened and closed at pressures determined by the spring preload applied to the plunger in the injector. Once the pressure in the injector reached a pre-determined level, the plunger would lift and injection would start.

In common rail systems, a high-pressure pump stores a reservoir of fuel at high pressure — up to and above 2,000 bars (200 MPa; 29,000 psi). The term "common rail" refers to the fact that all of the fuel injectors are supplied by a common fuel rail which is nothing more than a pressure accumulator where the fuel is stored at high pressure.

This accumulator supplies multiple fuel injectors with high-pressure fuel. This simplifies the purpose of the high-pressure pump in that it only needs to maintain a commanded pressure at a target (either mechanically or electronically controlled). The fuel injectors are typically ECU-controlled. When the fuel injectors are electrically activated, a hydraulic valve (consisting of a nozzle and plunger) is mechanically or hydraulically opened and fuel is sprayed into the cylinders at the desired pressure.

Since the fuel pressure energy is stored remotely and the injectors are electrically actuated, the injection pressure at the start and end of injection is very near the pressure in the accumulator (rail), thus producing a square injection rate. If the accumulator, pump and plumbing are sized properly, the injection pressure and rate will be the same for each of the multiple injection events.

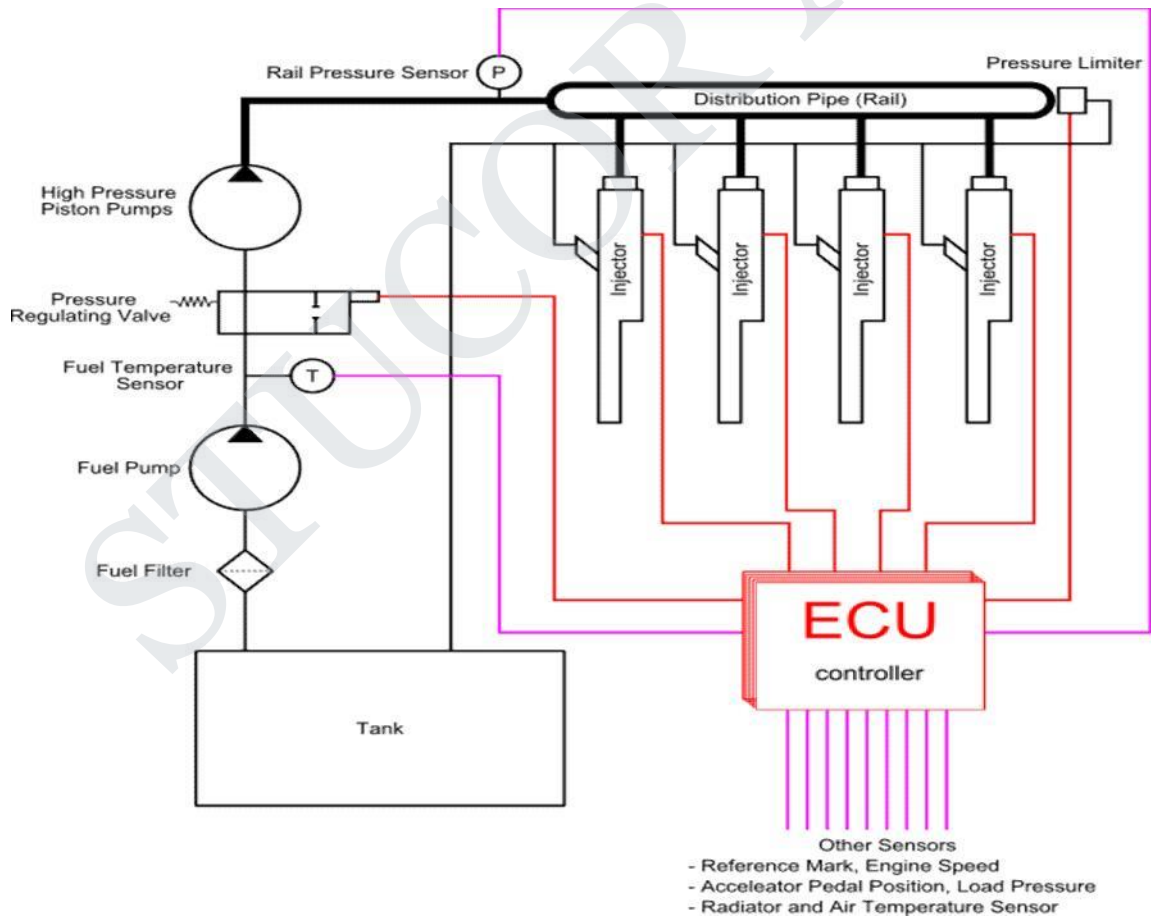

2.5. Turbocharger:

The turbo charger utilizes the wasted heat energy in the exhaust system, to run a compressor which compresses the intake air. Compressed intake air has more density and hence more fuel can be injected increasing the power of the engine. Turbo charging is an ideal way to increase the engine power without increasing the engine size.

A turbocharger, or turbo (colloquialism), from Greek "τύρβη" ("wake"), (also from Latin "turbo" ("spinning top")), is a turbine-driven forced induction device that increases an engine's efficiency and power by forcing extra air into the combustion chamber. This improvement over a naturally aspirated engine's output results because the turbine can force more air, and proportionately more fuel, into the combustion chamber than atmospheric pressure alone.

Turbochargers were originally known as turbosuperchargers when allforced induction devices were classified as superchargers. Nowadays the term "supercharger" is usually applied to only mechanically driven forced induction devices. The key difference between a turbocharger and a conventional supercharger is that the latter is mechanically driven by the engine, often through a belt connected to the crankshaft, whereas a turbocharger is powered by a turbine driven by the engine's exhaust gas. Compared to a mechanically driven supercharger, turbochargers tend to be more efficient, but less responsive. Twincharger refers to an engine with both a supercharger and a turbocharger.

Turbochargers are commonly used on truck, car, train, aircraft, and construction equipment engines. They are most often used with Otto cycle and Diesel cycle internal combustion engines. They have also been found useful in automotive fuel cells.

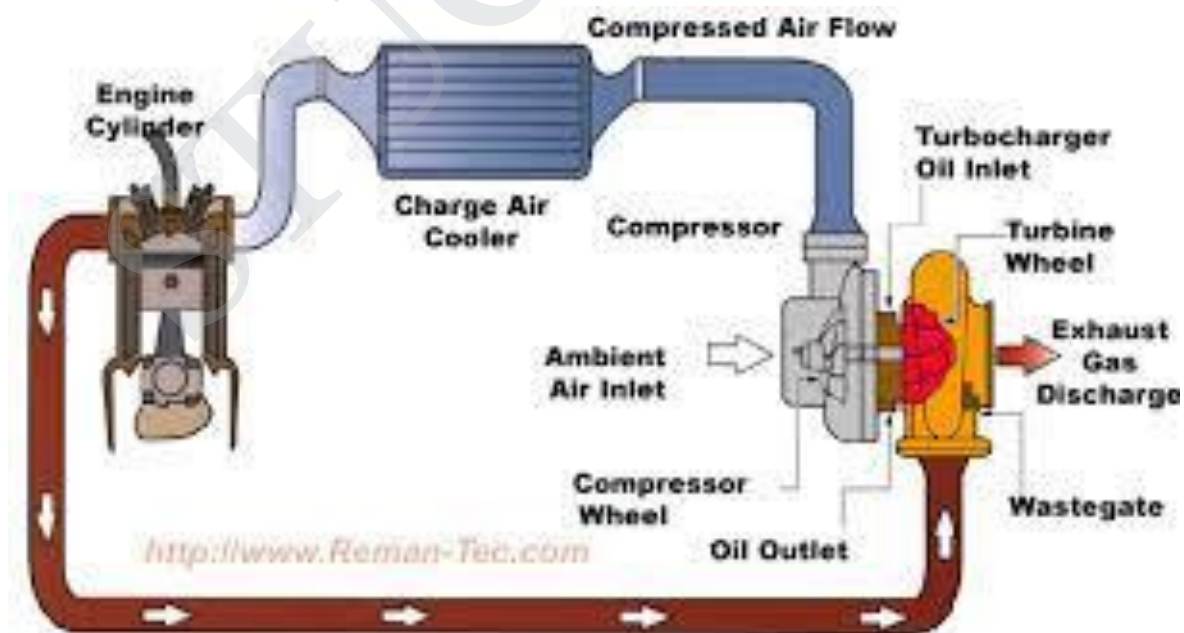

2.6. Catalytic converter

Catalytic converter is a vehicle emissions control device that converts toxic pollutants in exhaust gas to less toxic pollutants by catalyzing a redox reaction (oxidation or reduction). Catalytic converters are used in internal combustion engines fueled by either petrol (gasoline) or diesel—including lean burn engines.

The first widespread introduction of catalytic converters was in the United States automobile market. Manufacturers of 1975 model year equipped gasoline-powered vehicles with catalytic converters to comply with the U.S. Environmental Protection Agency's stricter regulation of exhaust emissions. These “two-way” converters combined carbon monoxide (CO) with unburned hydrocarbons (HC) to produce carbon dioxide (CO₂) and water (H₂O). In 1981, two-way catalytic converters were rendered obsolete by “three-way” converters that also reduce oxides of nitrogen (NO_x); however, two-way converters are still used for lean burn engines.

Although catalytic converters are most commonly applied to exhaust systems in automobiles, they are also used on electrical generators, forklifts, mining equipment, trucks, buses, locomotives, motorcycles, and airplanes. They are also used on some wood stoves to control emissions. This is usually in response to government regulation, either through direct environmental regulation or through health and safety regulations.

Construction of a catalytic converter;

The catalyst support or substrate. For automotive catalytic converters, the core is usually a ceramic monolith with a honeycomb structure. Metallic foil monoliths made of Kanthal (FeCrAl) are used in applications where particularly high heat resistance is required. Either material is designed to provide a large surface area. The cordierite ceramic substrate used in most catalytic converters was invented by Rodney Bagley, Irwin Lachman and Ronald Lewis at Corning Glass, for which they were inducted into the National Inventors Hall of Fame in 2002.

The washcoat. A washcoat is a carrier for the catalytic materials and is used to disperse the materials over a large surface area. Aluminum oxide, titanium dioxide, silicon dioxide, or a mixture of silica and alumina can be used. The catalytic materials are suspended in the washcoat prior to applying to the core. Washcoat materials are selected to form a rough, irregular surface, which greatly increases the surface area compared to the smooth surface of the bare substrate. This in turn maximizes the catalytically active surface available to react with the engine exhaust. The coat must retain its surface area and prevent sintering of the catalytic metal particles even at high temperatures.

The catalyst itself is most often a mix of precious metals. Platinum is the most active catalyst and is widely used, but is not suitable for all applications because of unwanted additional reactions and high cost. Palladium and rhodium are two other precious metals used. Rhodium is used as a reduction catalyst, palladium is used as an oxidation catalyst, and platinum is used both for

reduction and oxidation. Cerium, iron, manganese and nickel are also used, although each has limitations. Nickel is not legal for use in the European Union because of its reaction with carbon monoxide into toxic nickel tetracarbonyl.[citation needed] Copper can be used everywhere except North America,[clarification needed]where its use is illegal because of the formation of toxic dioxin .[citation needed]

CATALYTIC CONVERTER

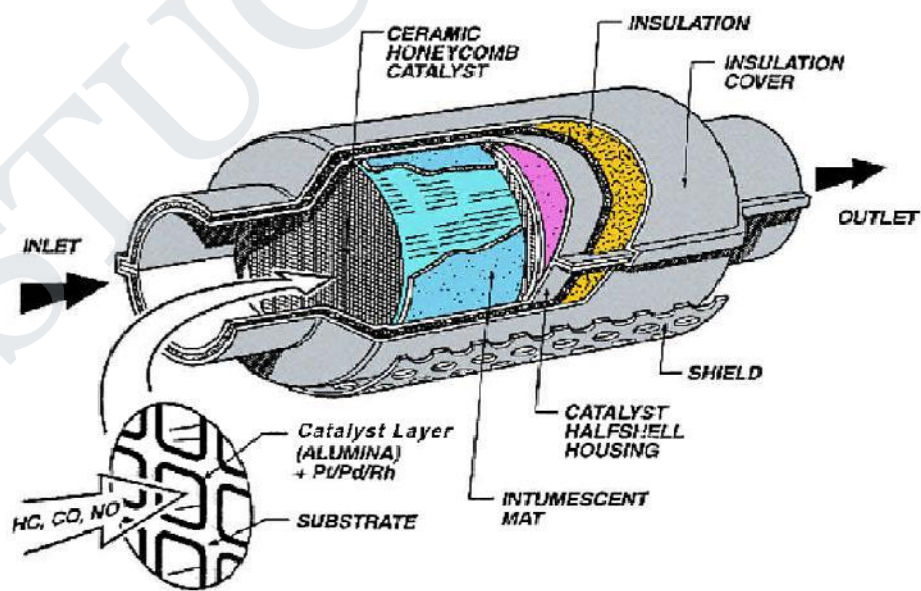
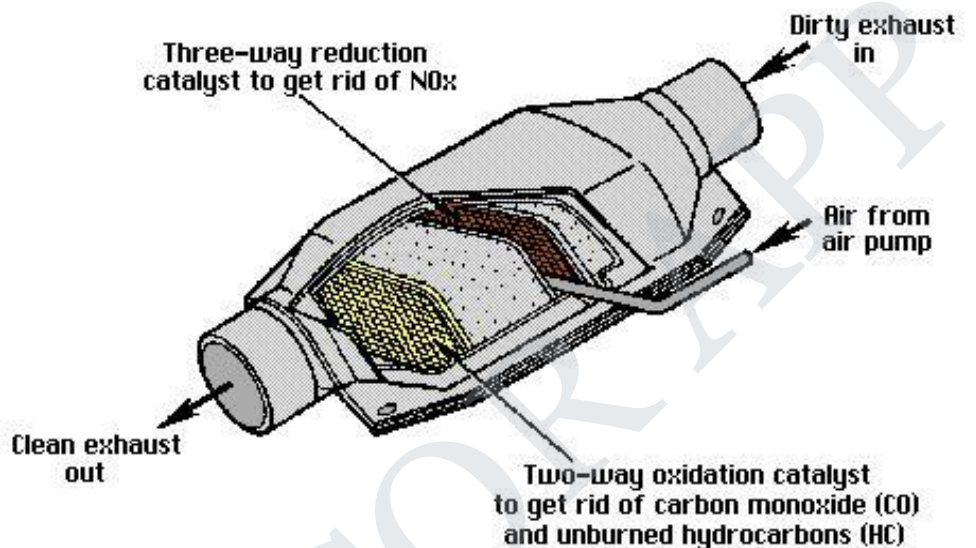

UNIT-III
TRANSMISSION SYSTEMS

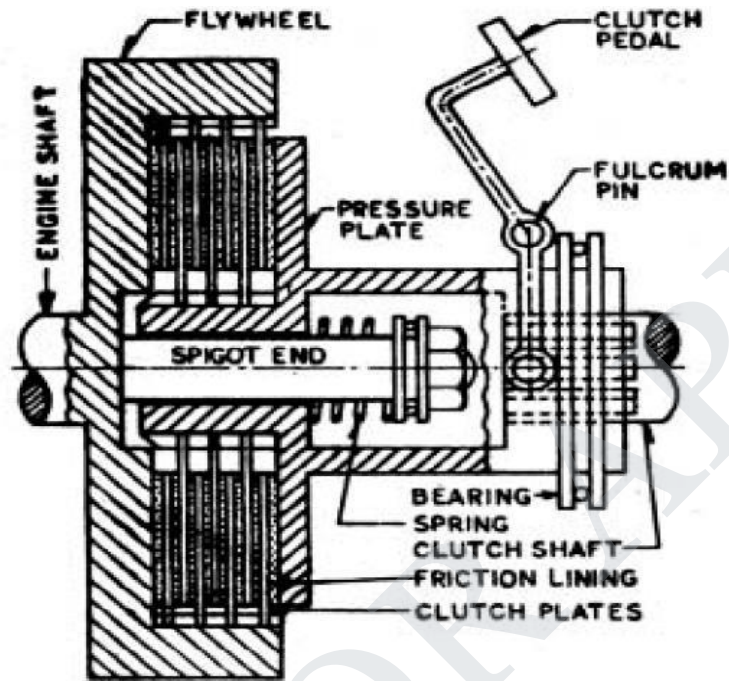
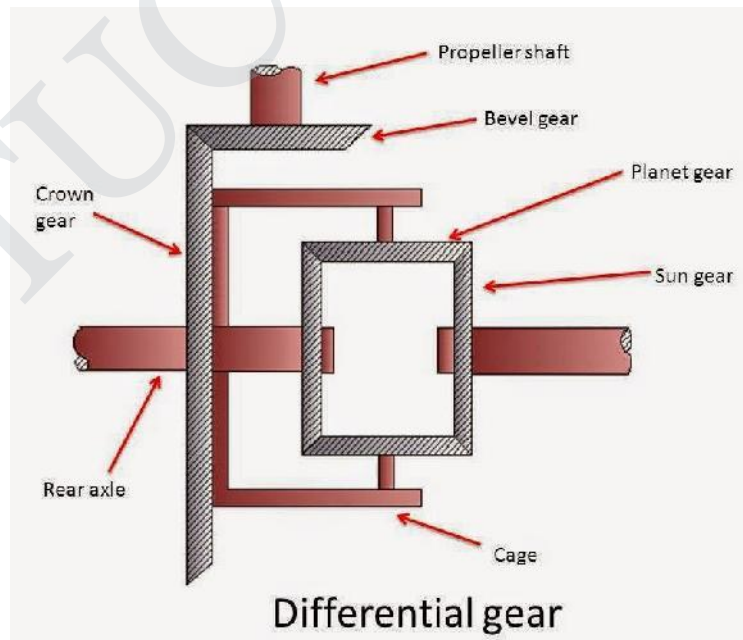
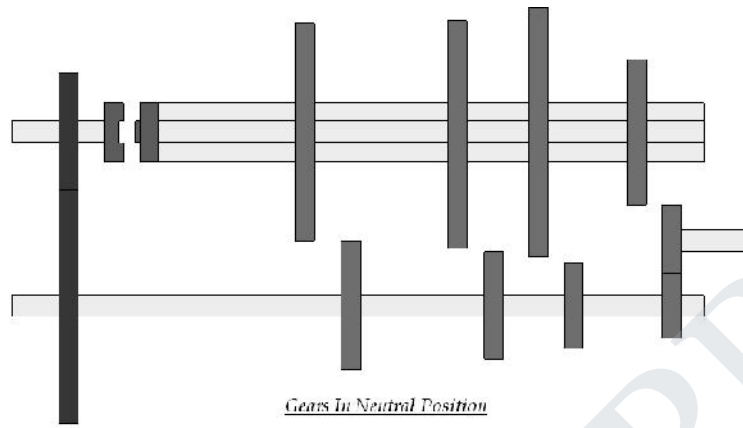
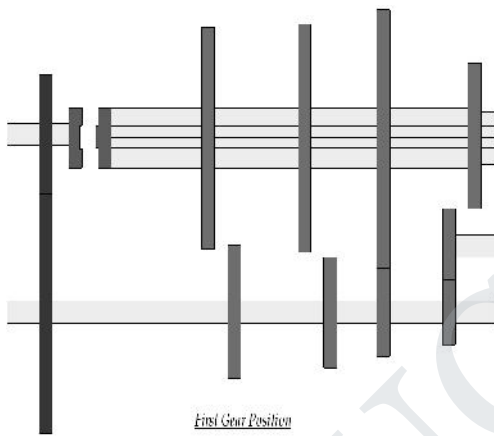

Fig : Multi-Plate Clutch





Gears In Neutral Position



First Gear Position

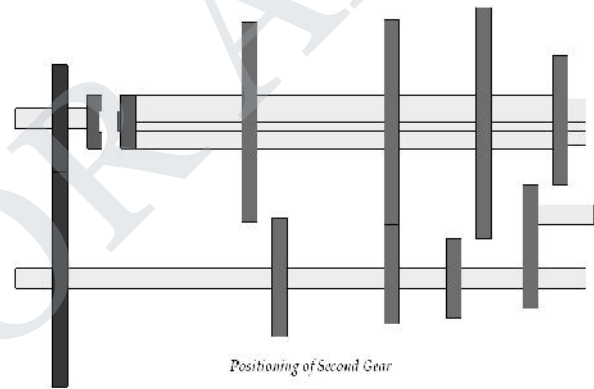

Positioning of Second Gear

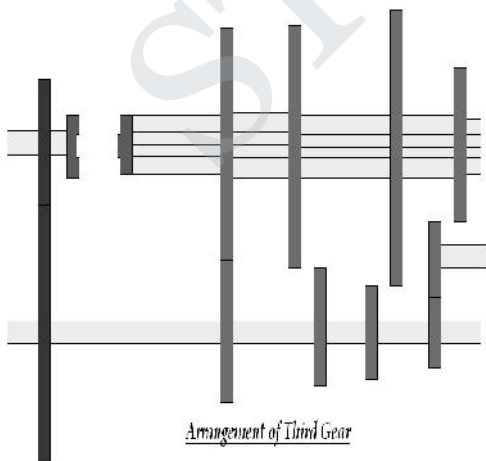

Arrangement of Third Gear

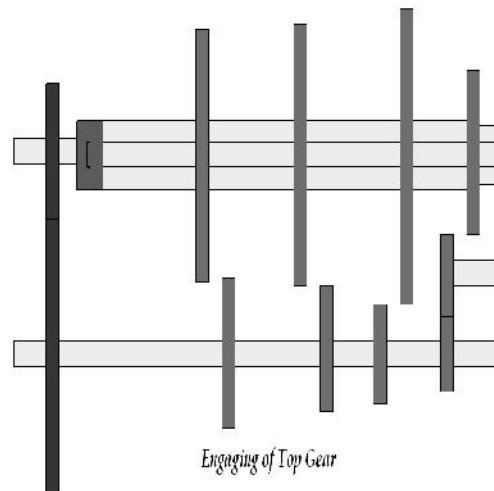

Engaging of Top Gear

3.1. Introduction to the Transmission Systems in Automobile:

The most common transmission systems that have been used for the automotive industry are:

- Manual transmission,
- Automatic transmission,
- Semi-automatic transmission,
- Continuously-variable transmission (C.V.T.).

3.1.1. Manual Transmission:

The first transmission invented was the manual transmission system. The driver needs to disengage the clutch to disconnect the power from the engine first, select the target gear, and engage the clutch again to perform the gear change. This will challenge a new driver. It always takes time for a new driver to get used to this skill.

3.1.2. Automatic Transmission:

An automatic transmission uses a fluid-coupling torque converter to replace the clutch to avoid engaging/disengaging clutch during gear change. A completed gear set, called planetary gears, is used to perform gear ratio change instead of selecting gear manually. A driver no longer needs to worry about gear selection during driving. It makes driving a car much easier, especially for a disabled or new driver. However, the indirect gear contact of the torque converter causes power loss during power transmission, and the complicated planetary gear structure makes the transmission heavy and easily broken.

3.1.3. Semi-Automatic Transmission:

A semi-automatic transmission tries to combine the advantages of the manual and automatic transmission systems, but avoid their disadvantages. However, the complicated design of the semi-automatic transmission is still under development, and the price is not cheap. It is only used for some luxury or sports cars currently.

Continuously Variable Transmission (C.V.T.):-

The Continuously Variable Transmission (C.V.T.) is a transmission in which the ratio of the rotational speeds of two shafts, as the input shaft and output shaft of a vehicle or other machine, can be varied continuously within a given range, providing an infinite number of possible ratios. The other mechanical transmissions described above only allow a few different gear ratios to be selected, but this type of transmission essentially has an infinite number of ratios available within a finite range.

It provides even better fuel economy if the engine is constantly made run at a single speed. This transmission is capable of a better user experience, without the rise and fall in speed of an engine, and the jerk felt when changing gears.

MANUAL TRANSMISSION SYSTEM

Manual transmissions also referred as stick shift transmission or just 'stick', 'straight drive', or standard transmission because you need to use the transmission stick every time you change the gears. To perform the gear shift, the transmission system must first be disengaged from the engine. After the target gear is selected, the transmission and engine are engaged with each other again to perform the power transmission. Manual transmissions are characterized by gear ratios that are selectable by locking selected gear pairs to the output shaft inside the transmission.

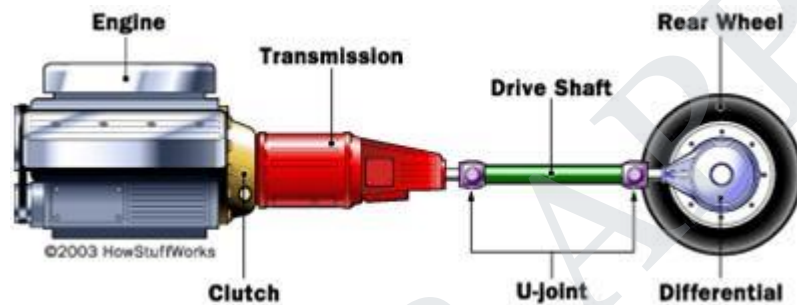

The transmission system delivers the engine power to wheels.

Components of manual transmission

The main components of manual transmission are:

- Clutch
- Gear box
- U- joint
- Shafts
- Differential gear box

3.2. Clutch;

Clutch is a device which is used in the transmission system of automobile to engage and disengage the engine to the transmission or gear box. It is located between the transmission and the engine. When the clutch is engaged, the power flows from the engine to the rear wheels in a rear-wheel-drive transmission and the vehicle moves. When the clutch is disengaged, the power is not transmitted from the engine to the rear wheels and vehicle stops even if engine is running.

It works on the principle of friction. When two friction surfaces are brought in contact with each other and they are united due to the friction between them. If one is revolved the other will also revolve.

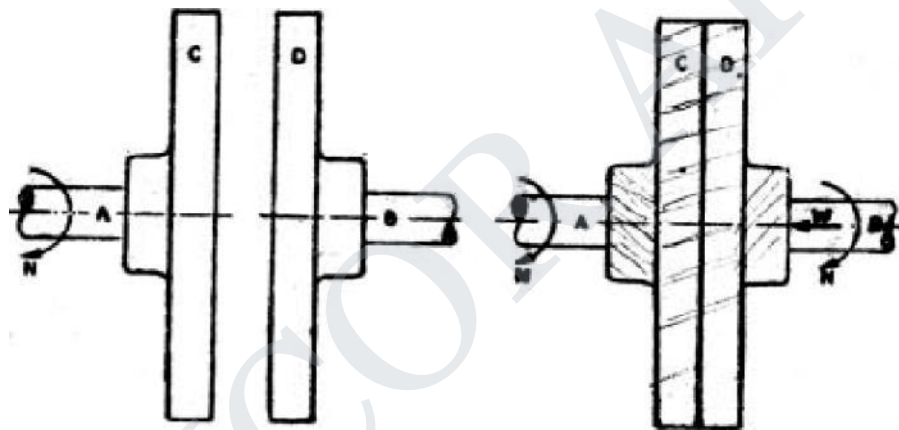

Fig: Principle of Clutch

The friction depends upon the surface area contact. The friction surfaces are so designed that the driven member initially slips on driving member when initially pressure is applied. As pressure increases the driven member is brought gradually to speed the driving member.

The three main parts of clutch are:

- Driving member
- Driven member
- Operating member

The driving member consists of a flywheel mounted on the engine crank shaft. The flywheel is bolted to cover which carries a pressure plate or driving disc, pressure springs and releasing levers. Thus the entire assembly of flywheel and cover rotates all the times. The clutch housing and the cover provided with openings dissipate the heat generated by friction during the clutch operation.

The driving member consists of a disc or plate called clutch plate. It is free to slide length wise on the splines of the clutch shaft. It carries friction materials on both of its surfaces when it is gripped between the flywheel and the pressure plate; it rotates the clutch shaft through splines.

The operating members consists of a foot pedal, linkage, release or throw-out bearing, release levers and springs necessary to ensure the proper operation of the clutch.

Now the driving member in an automobile is flywheel mounted on crank shaft, the driven member is the pressure plate mounted on transmission or gear box input shaft. Friction surfaces or clutch plates is placed between two members.

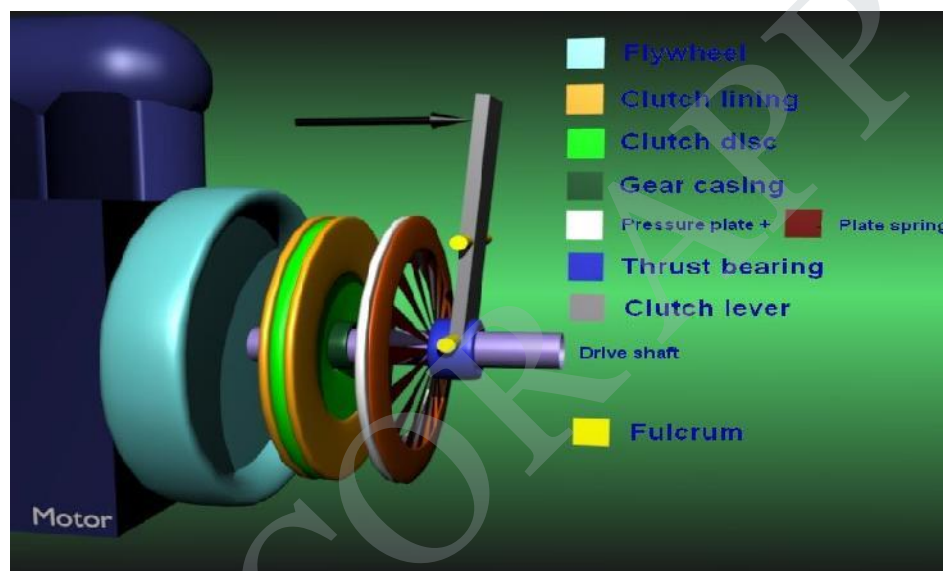

Fig: Exploded view of clutch

Types of Friction Materials:

The friction materials of the clutch plate are generally of 3 types:

- Mill Board Type
- Molded type
- Woven type

Mill Board type friction materials mainly include asbestos material with different types of impregnates.

Molded type friction materials are made from a matrix of asbestos fiber and starch or any other suitable binding materials. They are then heated to a certain temperature for moulding in dies under pressure. They are also made into sheets by rolling, pressing and backs till they are extremely hard and dense. Metallic wires are used sometimes to increase wear properties.

Woven types facing materials are made by impregnating a cloth with certain binders or by weaving threads of copper or brass wires covered with long fiber asbestos and cotton. The woven sheets treated with binding solution are baked and rolled.

TABLE: COEFFICIENTS OF FRICTION FOR CLUTCH FACING MATERIALS

Sl. No.	Material	Coefficient Of Material(μ)
1.	Leather	0.27
2.	Cork	0.37
3.	Cotton fabric	0.4-0.5
4.	Asbestos Base Materials	0.35-0.4

Properties Of Good Clutching:

- Good Wearing Properties
- High Resistance to heat
- High coefficient of friction
- Good Binders in it

Operation Of Clutch:

When the clutch pedal is pressed through pedal movement, the clutch release bearing presses on the clutch release lever plate which being connected to clutch release levers, forces these levers forward. This causes the pressure plate to compress pressure springs, thus allowing it to move away from the clutch driven plate. This action releases the pressure on the driven plate and flywheel, the flywheel is now free to turn independently, without turning the transmission.

When the clutch pedal is released, reverse action takes place i.e. the driven plate is again forced against the flywheel by the pressure plate- because of the force exerted by pressure springs. The pressure plate will keep on pressing the facings of driven plate until friction created becomes equal to the resistance of the vehicle. Any further increase in pressure will cause the clutch plate and the transmission shaft to turn along with flywheel, thus achieving vehicle movement.

3.2.1. Single Clutch Plate:

It is the most common type of clutch plate used in motor vehicles. Basically it consists of only one clutch plate, mounted on the splines of the clutch shaft. The flywheel is mounted on engine crankshaft and rotates with it. The pressure plate is bolted to the flywheel through clutch springs, and is free to slide on the clutch shaft when the clutch pedal is operated. When the clutch is engaged the clutch plate is gripped between the flywheel and pressure plate. The friction linings are on both the sides of the clutch plate. Due to the friction between the flywheel, clutch plate and the pressure plate the clutch plate revolves the flywheel. As the clutch plate revolves the clutch shaft also revolves. Clutch shaft is connected to the transmission gear box. Thus the engine power is transmitted to the crankshaft and then to the clutch shaft.

When the clutch pedal is pressed, the pressure plate moves back against the force of the springs, and the clutch plate becomes free between the flywheel and the pressure plate. Thus the flywheel remains rotating as long as the engine is running and the clutch shaft speed reduces slowly and finally it stops rotating. As soon as the clutch pedal is pressed, the clutch is said to be engaged, otherwise it remains engaged due to the spring forces.

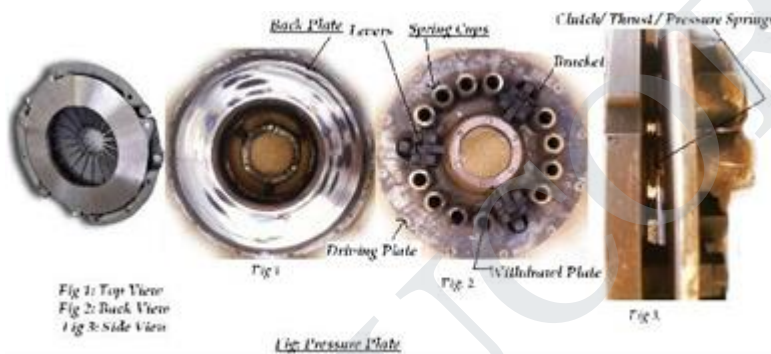

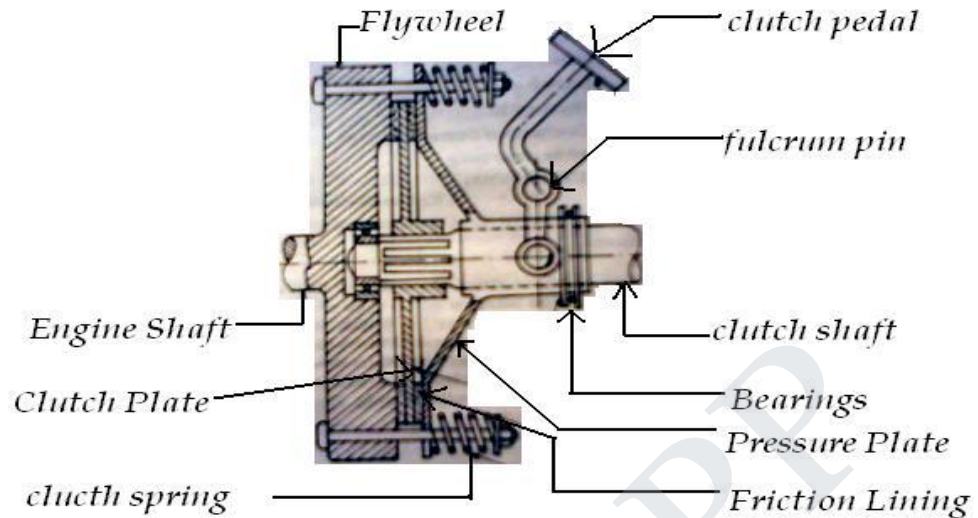

Fig: Single Plate Clutch

3.2.2. Multi-plate Clutch:

Multi-plate clutch consists of a number of clutch plates instead of only one clutch plate as in case of single plate clutch. As the number of clutch plates are increased, the friction surfaces also increase. The increased number of friction surfaces obviously increases the capacity of the clutch to transmit torque.

The plates are alternately fitted to engine and gear box shaft. They are firmly pressed by strong coil springs and assembled in a drum. Each of the alternate plate slides on the grooves on the flywheel and the other slides on splines on the pressure plate. Thus, each alternate plate has inner and outer splines.

The multi-plate clutch works in the same way as a single plate clutch by operating the clutch pedal. The multi-plate clutches are used in heavy commercial vehicles, racing cars and motor cycles for transmitting high torque. The multi-plate clutch may be dry or wet. When the clutch is operated in an oil bath, it is called a wet clutch. When the clutch is operated dry it is called dry clutch. The wet clutch is used in conjunction with or part of the automatic transmission.

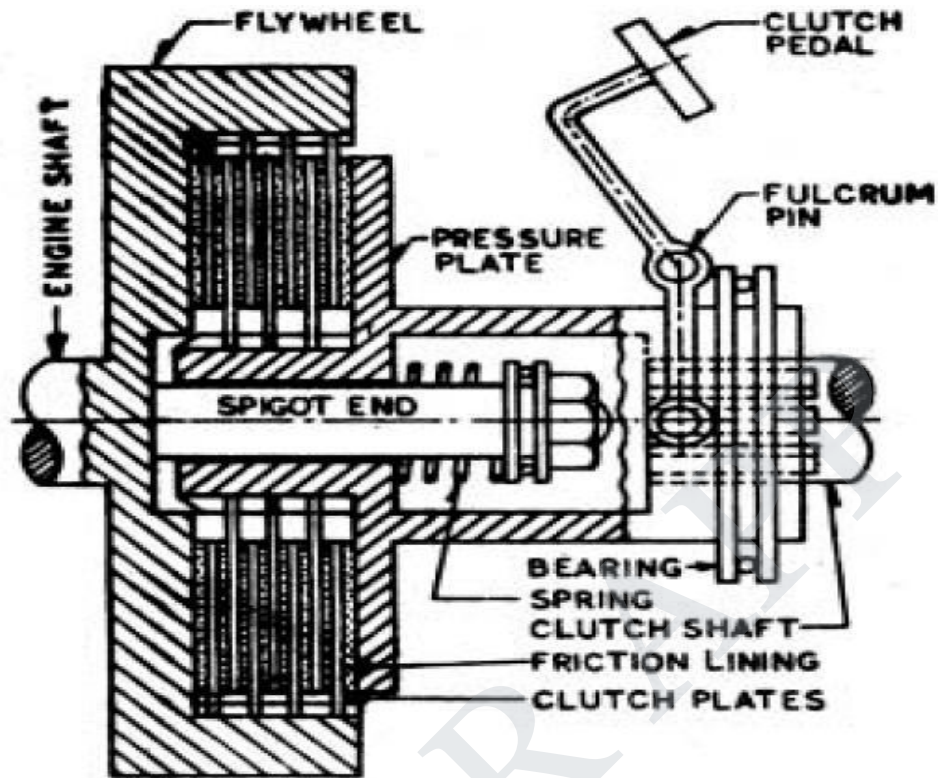

Fig : Multi-Plate Clutch



Fig: Cutway Model Of Multi-Plate Clutch



Fig: Exploded View Of Multi-Plate Clutch

Fig: Multi-Plate Clutch

3.2.3.Cone Clutch:

Cone clutch consists of friction surfaces in the form of cone. The engine shaft consists of female cone. The male cone is mounted on the splined clutch shaft. It has friction surfaces on the conical portion. The male cone can slide on the clutch shaft. When the clutch is engaged the friction surfaces of the male cone are in contact with that of the female cone due to force of the spring. When the clutch pedal is pressed, the male cone slides against the spring force and the clutch is

disengaged.

The only advantage of the cone clutch is that the normal force acting on the friction surfaces is greater than the axial force, as compare to the single plate clutch in which the normal force acting on the friction surfaces is equal to the axial force. The disadvantage in cone clutch is that if the angle of the cone is made smaller than 200 the male cone tends to bind in the female cone and it becomes difficult to disengage the clutch. Cone clutches are generally now only used in low peripheral speed applications although they were once common in automobiles and other combustion engine transmissions. They are usually now confined to very specialist transmissions in racing, rallying, or in extreme off-road vehicles, although they are common in power boats. Small cone clutches are used in synchronizer mechanisms in manual transmissions.

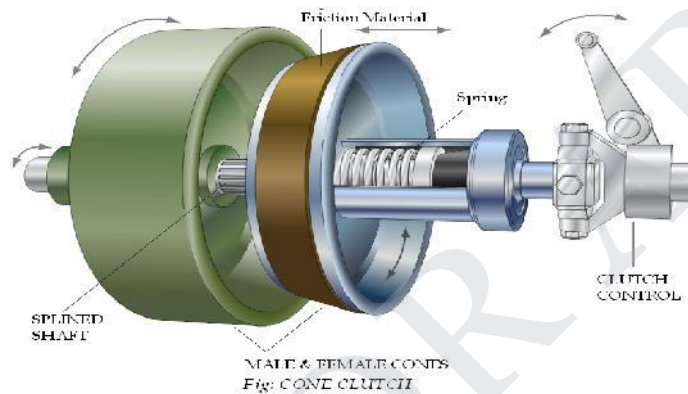

3.2.4. Dog & Spline Clutch:

This type of clutch is used to lock two shafts together or to lock a gear to shaft. It consists of a sleeve having two sets of internal splines. It slides on a splined shaft with smallest diameter splines. The bigger diameter splines match with the external dog clutch teeth on driving shaft. When the sleeve is made to slide on the splined shaft, its teeth match with the dog clutch teeth of the driving shaft. Thus the sleeve turns the splined shaft with the driving shaft.

The clutch is said to be engaged. To disengage the clutch, the sleeve is moved back on the splined shaft to have no contact with the driving shaft. This type of clutch has no tendency to slip. The driven shaft revolves exactly at the same speed of the driving shaft, as soon as the clutch is engaged. This is also known as positive clutch.

3.2.5. Centrifugal Clutch:

The centrifugal clutch uses centrifugal forces, instead of spring force for keeping it in engaged position. Also, it does not require clutch pedal for operating the clutch. The clutch is

operated automatically depending on engine speed. The vehicle can be stopped in gear without stalling the engine. Similarly the gear can be started in any gear by pressing the accelerator pedal.

A centrifugal clutch works through centrifugal force. The input of the clutch is connected to the engine crankshaft while the output drives gear box shaft, chain, or belt. As engine R.P.M. increases, weighted arms in the clutch swing outward and force the clutch to engage. The most common types have friction pads or shoes radially mounted that engage the inside of the rim of housing.

On the center shaft there are an assorted amount of extension springs, which connect to a clutch shoe. When the center shaft spins fast enough, the springs extend causing the clutch shoes to engage the friction face. It can be compared to a drum brake in reverse. The weighted arms force these disks together and engage the clutch.

When the engine reaches a certain RPM, the clutch activates, working almost like a continuously variable transmission. As the load increases the R.P.M. drops thereby disengaging the clutch and letting the rpm rise again and reengaging the clutch. If tuned properly, the clutch will tend to keep the engine at or near the torque peak of the engine.

These results in a fair bit of waste heat, but over a broad range of speeds it is much more useful than a direct drive in many applications. Weaker spring/heavier shoes will cause the clutch to engage at a lower R.P.M. while a stronger spring/lighter shoes will cause the clutch to engage at a higher R.P.M.

Semi-centrifugal Clutch:-

A semi centrifugal clutch is used to transmit power from high powered engines and racing car engines where clutch disengagements requires appreciable and tiresome drivers effort. The transmission of power in such clutches is partly by clutch springs and rest by centrifugal action of an extra weight provided in system. The clutch springs serve to transmit the torque up to normal speeds, while the centrifugal force assists at speeds higher than normal.

Besides clutch, pressure plate and splines shaft it mainly consists of:

Compression spring (3 numbers)

Weighted levers (3 numbers)

At normal speeds when the power transmission is low the spring keeps the clutch engaged, the weighted levers do not have any pressure on the pressure plate. At high speed, when the power transmission is high the weights fly off and levers exert pressure on the plate which keeps the clutch firmly engaged. Thus instead of having more stiff springs for keeping the clutch engaged firmly at high speeds, they are less stiff, so that the driver may not get any strain in operating the clutch.

when the speed decreases, the weights fall and the levers do not exert any pressure on the pressure plate. Only the spring pressure is exerted on the pressure plate which is sufficient to keep the clutch engaged.

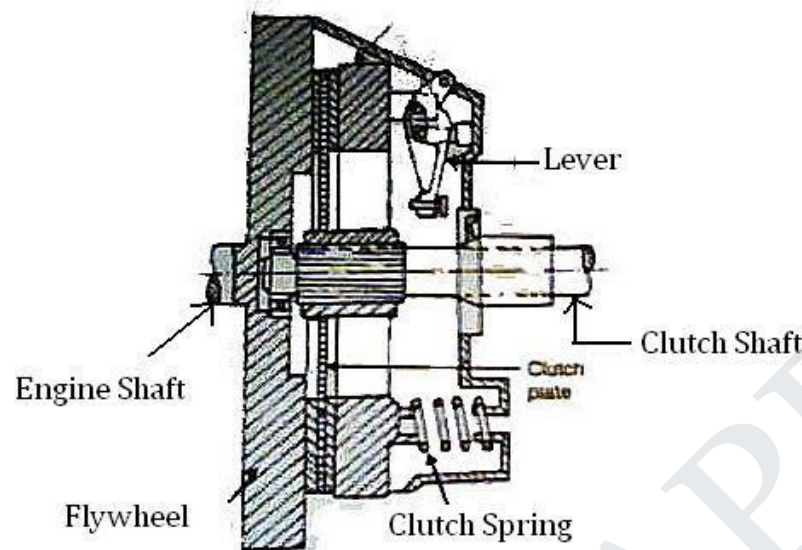

Fig: Semicentrifugal Clutch

3.2.6. Electromagnetic Clutch:

An electromagnetic clutch is a clutch (a mechanism for transmitting rotation) that is engaged and disengaged by an electromagnetic actuator. In this type of clutch, the flywheel consists of winding. The current is supplied to the winding from battery or dynamo.

When the current passes through the winding it produces an electromagnetic field which attracts the pressure plate, thereby engaging the clutch. When supply is cutoff, the clutch is disengaged. The gear lever consists of a clutch release switch. When then the driver holds the gear lever to change the gear the switch is operated cutting off the current to the winding which causes the clutch disengaged. At low speeds when the dynamo output is low, the clutch is not firmly engaged.

Therefore three springs are also provided on the pressure plate which helps the clutch engaged firmly at low speed also. Cycling is achieved by turning the voltage/current to the electromagnet on and off. Slippage normally occurs only during acceleration. When the clutch is fully engaged, there is no relative slip, assuming the clutch is sized properly, and thus torque transfer is 100% efficient.

The electromagnetic clutch is most suitable for remote operation since no linkages are required to control its engagement. It has fast, smooth operation. However, because energy dissipates as heat in the electromagnetic actuator every time the clutch is engaged, there is a risk of overheating. Consequently the maximum operating temperature of the clutch is limited by the temperature rating of the insulation of the electromagnet. This is a major limitation. Another disadvantage is higher initial cost.

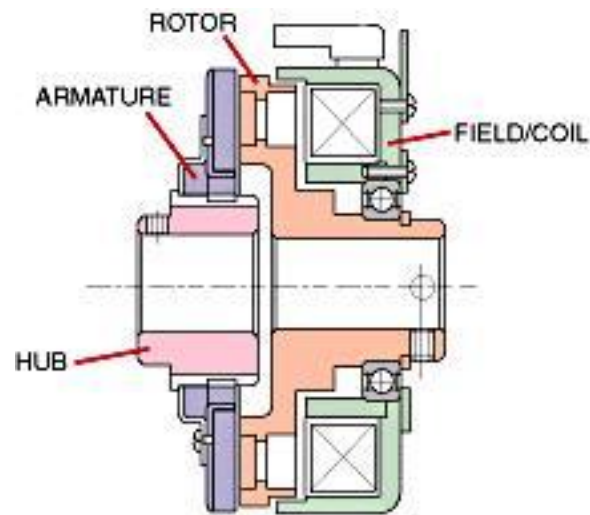

Fig: Electromagnetic Clutch

3.3.Gear Box;

A gearbox is a mechanical method of transferring energy from one device to another and is used to increase torque while reducing speed. Torque is the power generated through the bending or twisting of a solid material. This term is often used interchangeably with transmission. Located at the junction point of a power shaft, the gearbox is often used to create a right angle change in direction, as is seen in a rotary mower or a helicopter. Each unit is made with a specific purpose in mind, and the gear ratio used is designed to provide the level of force required. This ratio is fixed and cannot be changed once the box is constructed. The only possible modification after the fact is an adjustment that allows the shaft speed to increase, along with a corresponding reduction in torque. In a situation where multiple speeds are needed, a transmission with multiple gears can be used to increase torque while slowing down the output speed. This design is commonly found in automobile transmissions. The same principle can be used to create an overdrive gear that increases output speed while decreasing torque.

Principle Of Gearing

Consider a simple 4-gear train. It consists of a driving gear A on input shaft and a driven gear D on the output shaft. In between the two gears there are two intermediate gears B, C. Each of these gears are mounted on separate shaft. We notice that:

Gear A drives Gear B

$$\therefore \frac{N_b}{N_a} = \frac{T_a}{T_b}$$

Gear B drives Gear C

$$\therefore \frac{N_c}{N_b} = \frac{T_b}{T_c}$$

$$N_b \quad T_c$$

Gear C drives Gear D

$$\therefore \frac{N_d}{N_c} = \frac{T_c}{T_d}$$

Therefore, the over all speed ratios are:

$$\therefore \frac{N_d}{N_a} = \frac{T_c}{T_d} \times \frac{T_b}{T_c} \times \frac{T_a}{T_b} = \frac{T_a}{T_d}$$

3.3.1.Types of Gear Boxes: The following types of gear box are used in automobiles:

- Sliding Mesh
- Constant Mesh
- Synchromesh.

3.3.1. Sliding Mesh Gear Box

It is the simplest gear box. The following figure shows 4-speed gear box in neutral position. 4 gears are connected to the lay shaft/counter shaft. A reverse idler gear is mounted on another shaft and always remains connected to the reverse gear of countershaft. This “H” shift pattern enables the driver to select four different gear ratios and a reverse gear.

Gears in Neutral:

When the engine is running and clutch is engaged the clutch shaft gear drives the countershaft gear. The countershaft rotates opposite in direction of the clutch shaft. In neutral position only the clutch shaft gear is connected to the countershaft gear. Other gears are free and hence the transmission main shaft is not turning. The vehicle is stationary.

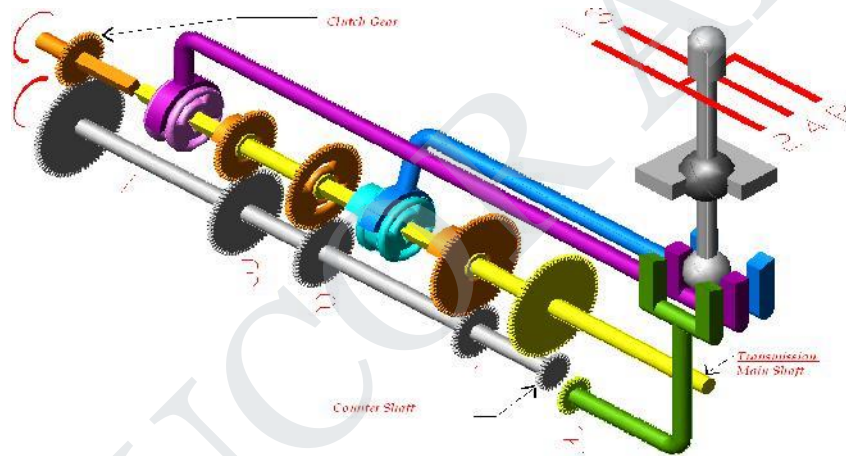
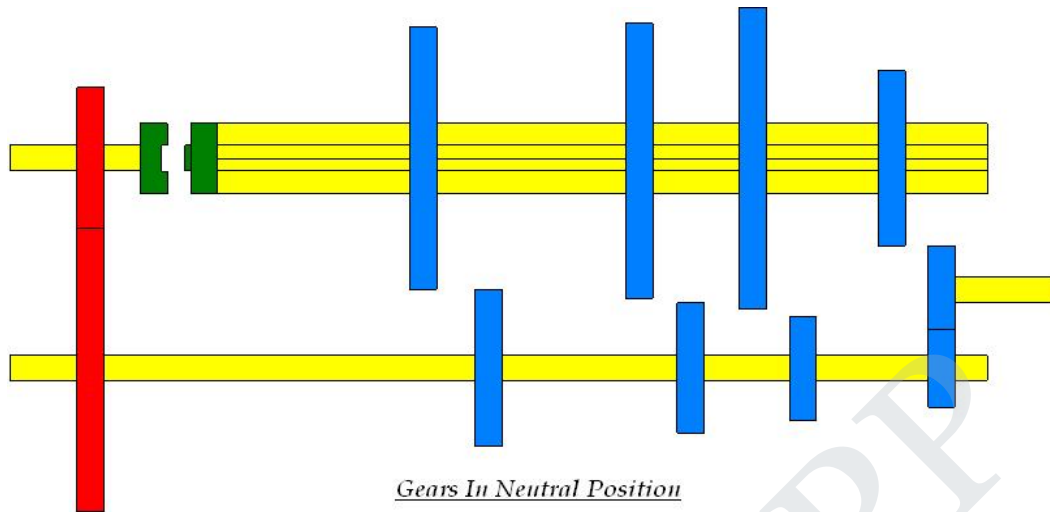

First or low shaft gear:

By operating the gear shift lever the larger gear on the main shaft is moved along the shaft to mesh with the first gear of the counter shaft. The main shaft turns in the same direction as that of the clutch shaft. Since the smaller countershaft is engaged with larger shaft gear a gear reduction of approximately 4:1 is obtained i.e. the clutch shaft turns 4 times for each revolution of main shaft.

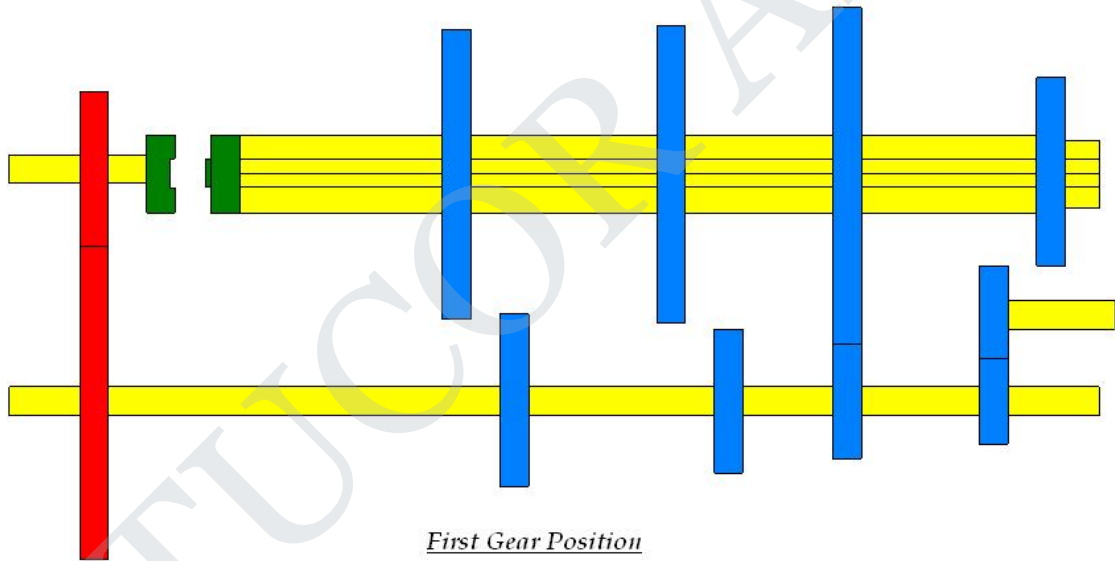
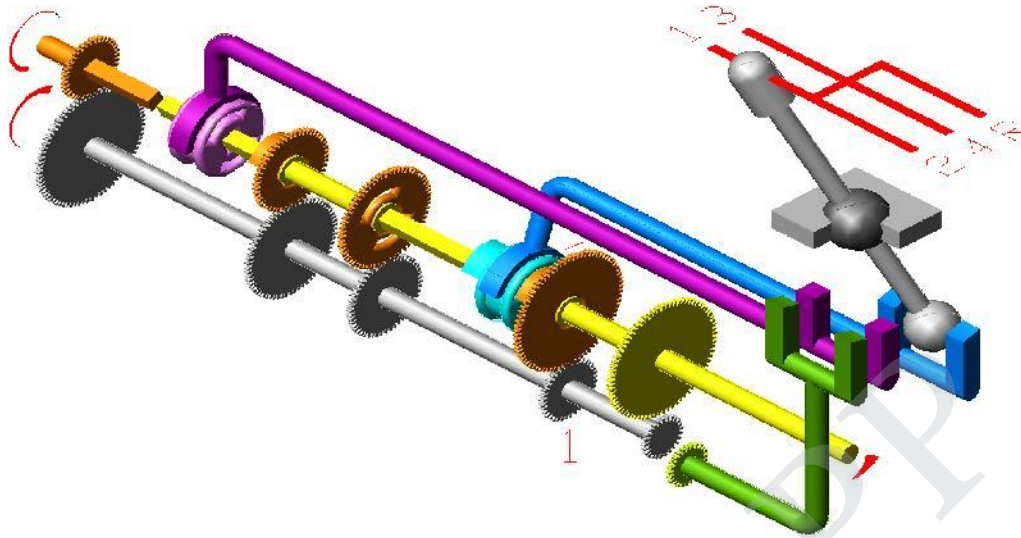

Second speed gear:

By operating the gear shift lever the third gear on the main shaft is moved along the shaft to mesh with the third gear of the counter shaft. The main shaft turns in same direction as clutch shaft. A gear reduction of approximately 3:1 is obtained.

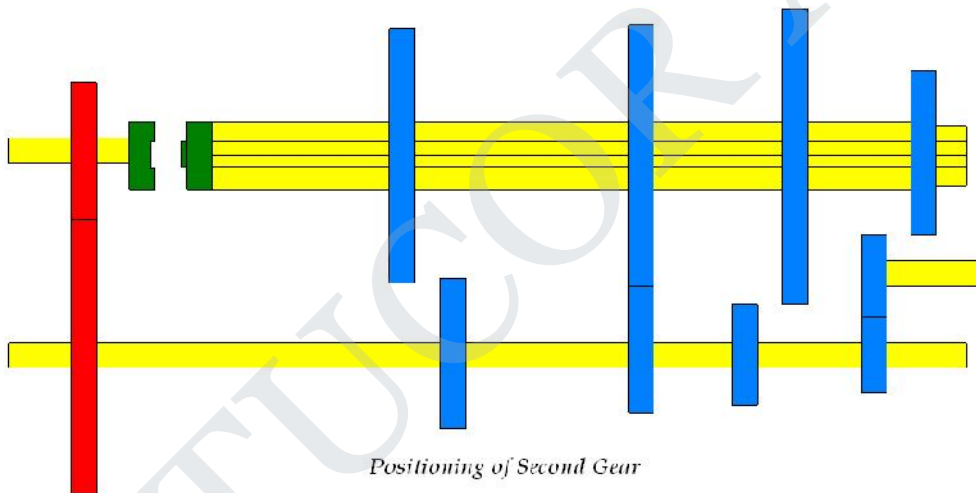
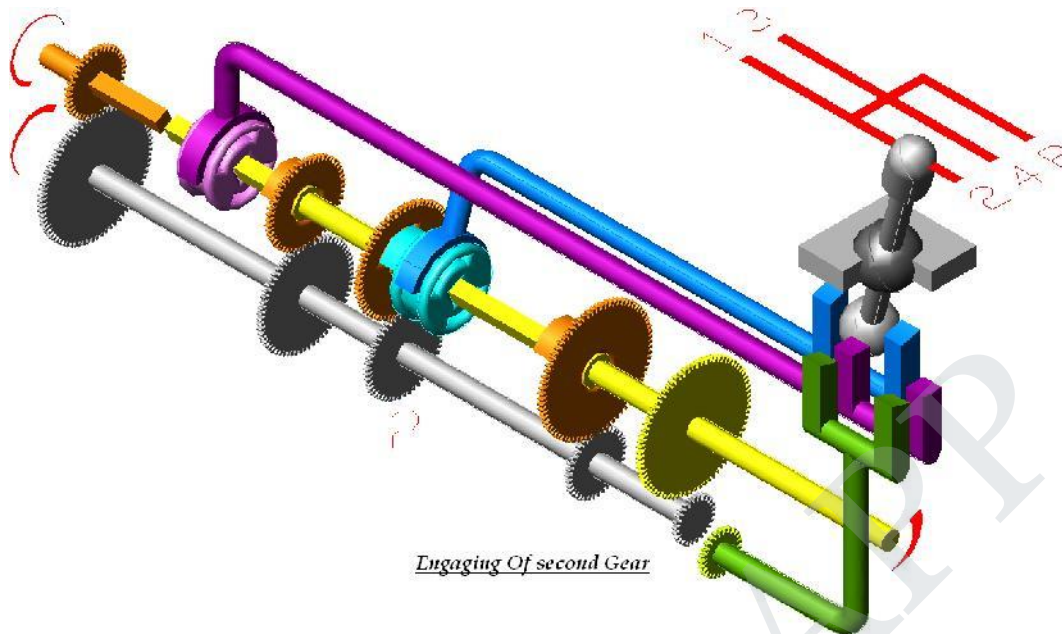

Third speed gear:

By operating the gear shift lever, the second gear of the main shaft and countershaft are demeshed and then the third gear of the main shaft are forced axially against the clutch shaft gear. External Teeth on the clutch shaft gear mesh with the internal teeth in the third and top gear. The main shaft turns in same direction as clutch shaft. A gear reduction of approximately 2:1 is obtained i.e. the clutch shaft turns 2 times for each revolution of main shaft.

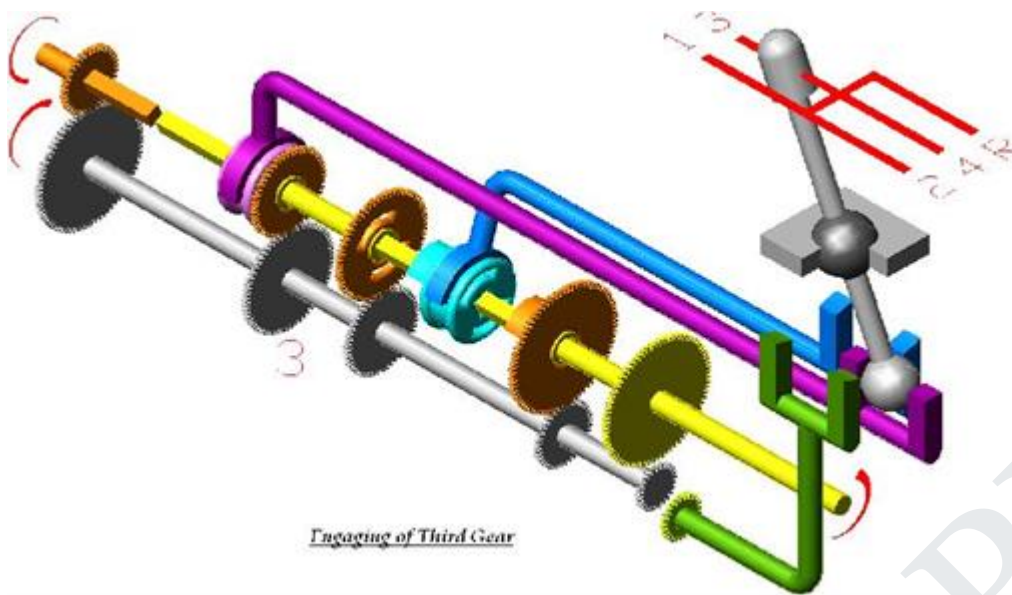

Engaging of Third Gear

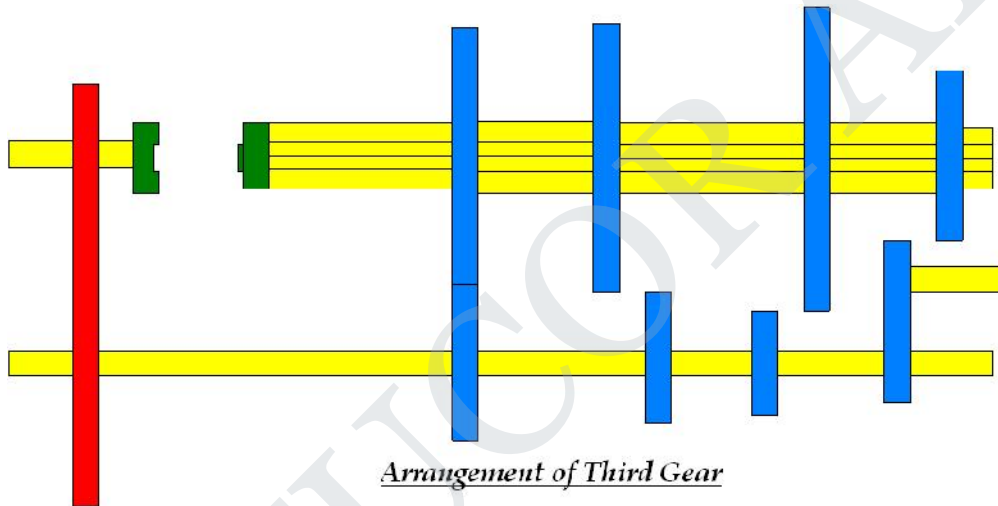

Arrangement of Third Gear

Fourth speed gear/ Top or High-Speed Gear:

By operating the gear shaft lever the third gears of the main and countershaft is demeshed and the gears present on the main shaft along with the shaft is forced axially against the clutch shaft gear. External teeth present on the main shaft engage with the internal teeth present on the main shaft. The main shaft turns along with the clutch shaft and a gear ratio of approximately 1:1 is obtained.

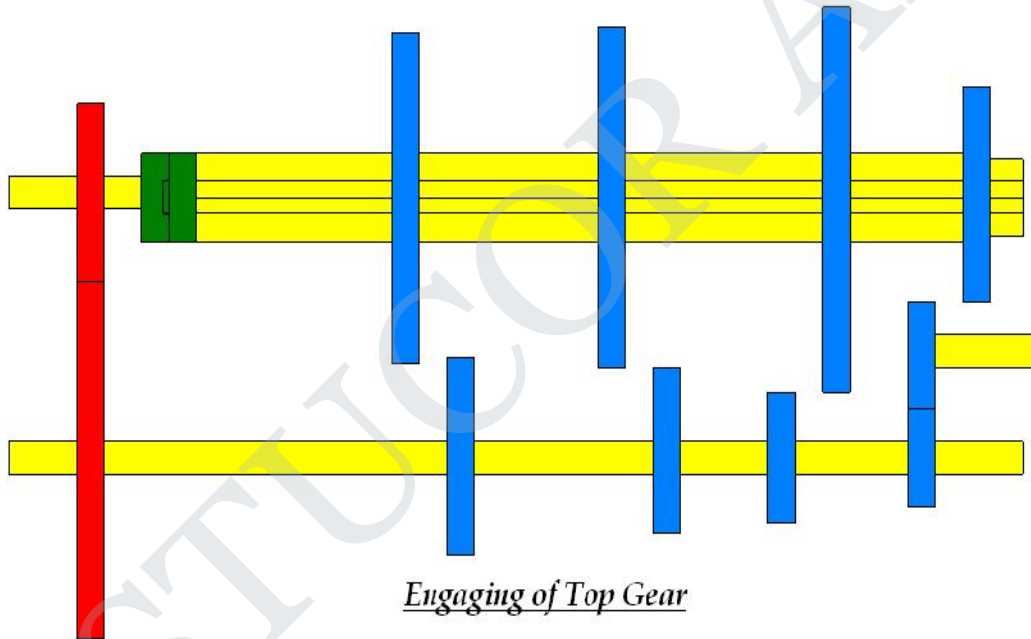
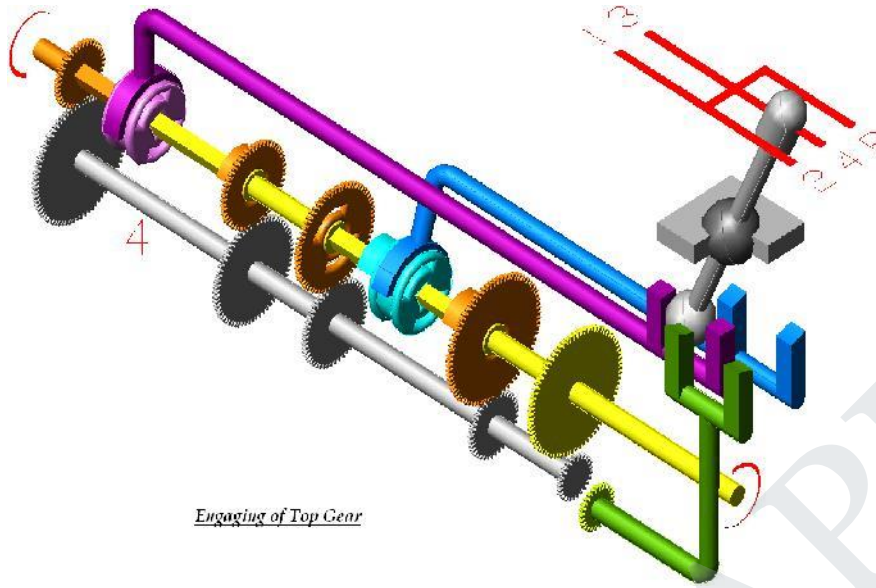

Reverse gear:

By operating the gear shift lever, the last gear present on the main shaft is engaged with the reverse idler gear. The reverse idler gear is always in mesh with the countershaft gear. Interposing the idler gear between the counter-shaft reverse gear and main shaft gear, the main shaft turns in the direction opposite to the clutch shaft. This reverses the rotation of the wheels so that the wheel backs.

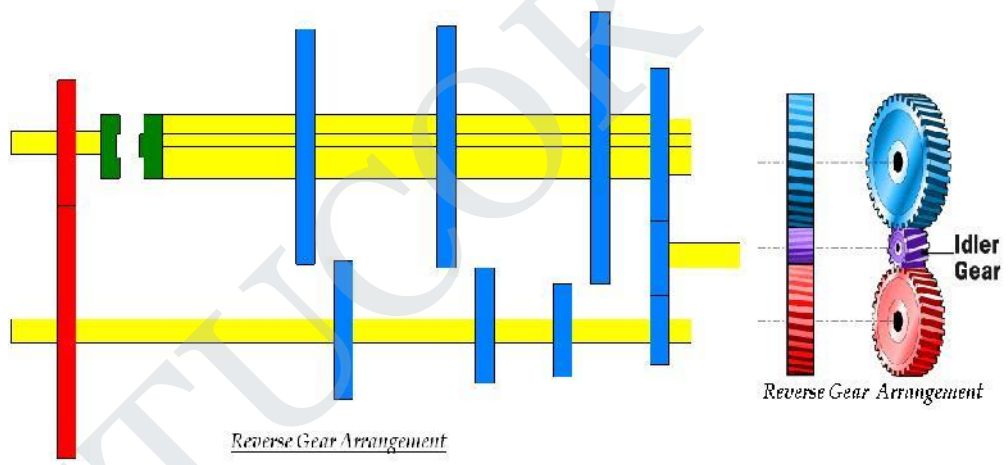
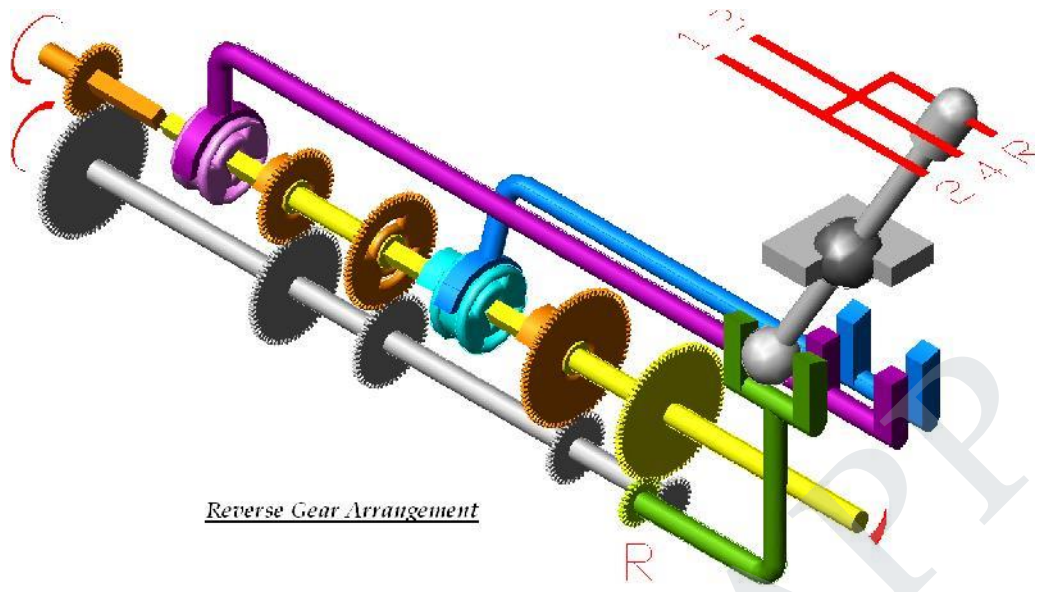

3.3.2.Constant Mesh Gear Box:

In this type of gear box, all gears of the main shaft are in constant mesh with the corresponding gears of the countershaft (Lay shaft). Two dog clutches are provided on the main shaft- one between the clutch gear and the second gear, and the other between the first gear and reverse gear. The main shaft is splined and all the gears are free on it. Dog clutch can slide on the shaft and rotates with it. All the gears on the countershaft are rigidly fixed with it.

When the left hand dog clutch is made to slide to the left by means of the gear shift lever, it meshes with the clutch gear and the top speed gear is obtained. When the left hand dog clutch meshes with the second gear, the second speed gear is obtained. Similarly by sliding the right hand dog clutch to the left and right, the first speed gear and reverse gear are obtained respectively. In this

gear box because all the gears are in constant mesh they are safe from being damaged and an unpleasant grinding sound does not occur while engaging and disengaging them.

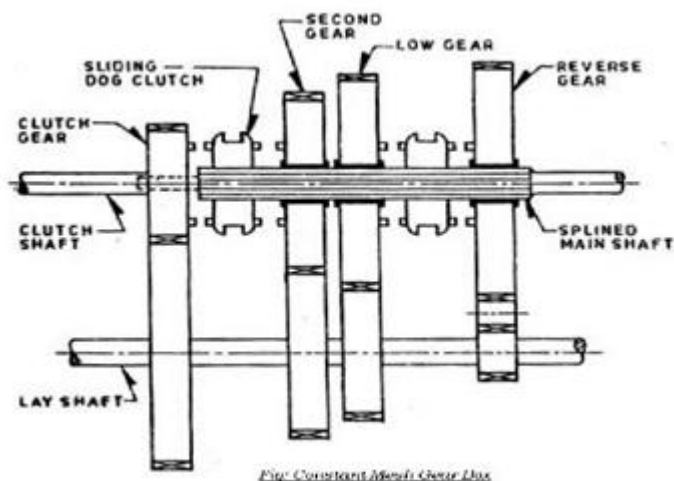

3.3.3. Synchromesh Gear Box:

In sliding Mesh Gear box the two meshing gears need to be revolve at equal peripheral speeds to achieve a jerk less engagement and it is true for constant mesh gear box in which the peripheral speeds of sliding dog and the corresponding gear on the output shaft must be equal. The peripheral speed is given by $V = \frac{\pi d_1 N_1}{60}$ Where d_1 and N_1 are pitch circle diameter and r.p.m. of gear and d_2 and N_2 diameter and r.p.m. of attached dog respectively.

The clutch is disengaged i.e. first declutching and the gear system is placed in its neutral position. Now the clutch is reengaged and acceleration pedal is pressed to adjust the engine speed according to driver's judgment. The clutch is disengaged (i.e. second declutching) again the appropriate gear is engaged and then the clutch is reengaged

It is that gear box in which sliding synchronizing units are provided in place of sliding dog clutches as in case of constant mesh gear box. With the help of synchronizing unit, the speed of both the driving and driven shafts is synchronized before they are clutched together through train of gears. The arrangement of power flow for the various gears remains the same as in constant mesh gear box. The synchronizer is made of frictional materials. When the collar tries to mesh with the gear, the synchronizer will touch the gear first and use friction force to drive the gear to spin at the same speed as the collar. This will ensure that the collar is meshed into the gear very smoothly without grinding. Synchromesh gear devices work on the principle that two gears to be engaged are first brought into frictional contact which equalizes their speed after which they are engaged readily and smoothly.

The following types of devices are mostly used in vehicles:

- Pin Type
- Synchronizer ring type

A synchronizing system is used for smooth meshing. Synchromesh works like a friction clutch. In the following figure two conical surfaces cone-1 is the part of the collar and the cone-2 is the part of the gear wheel. Cone1, 2 are revolving at different speeds. While cone-2 is revolving, cone-1 gradually slides into it. Friction slows or speeds up the gear wheel. Finally both the cones revolve at same speed.

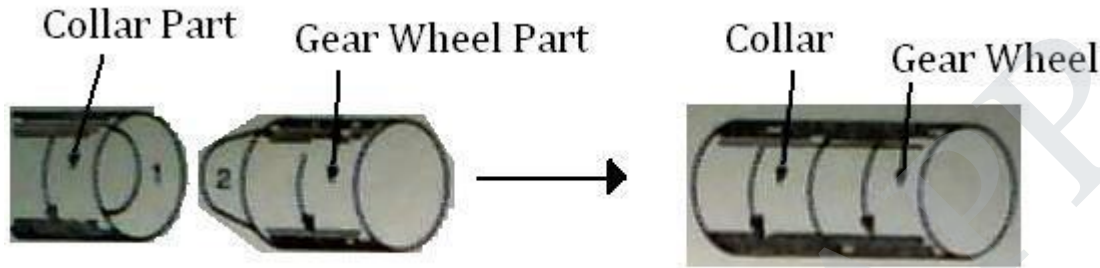

Fig: Two Cones acting as Friction Clutch

In the following Fig collar and gear wheel are separate and they are

revolving at different speeds. The internal cone comes in contact with the outer cone of the gear wheel. Friction slows or speeds up the gear wheel.

And when the collar and gear wheel rotate at same speed the spring loaded outer ring of the collar is pushed forward. The dog slide smoothly into mesh without clashing. The collar and gear wheel lock and revolve at same speed. This the principle of synchromesh.

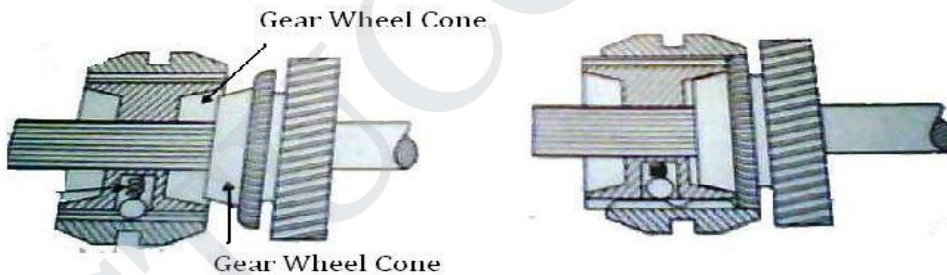

Fig: Synchro Mesh Unit

3.4. U- Joint:

A universal joint, U-joint, Cardan joint, Hardy-Spicer joint, or Hooke's joint is a linkage that transmits rotation between two non parallel shafts whose axes are coplanar but not coinciding., and is commonly used in shafts that transmit rotary motion. It is used in automobiles where it is used to transmit power from the gear box of the engine to the rear axle. The driving shaft rotates at a uniform angular speed, where as the driven shaft rotates at a continuously varying angular speed.

A complete revolution of either shaft will cause the other to rotate through a complete revolution at the same time. Each shaft has fork at its end. The four ends of the two fork are

connected by a centre piece, the arms of which rest in bearings, provided in fork ends. The centre piece can be of any shape of a cross, square or sphere having four pins or arms. The four arms are at right angle to each other.

When the two shafts are at an angle other than 180° (straight), the driven shaft does not rotate with constant angular speed in relation to the drive shaft; the more the angle goes toward 90° the jerkier the movement gets (clearly, when the angle $\beta = 90^\circ$ the shafts would even lock). However, the overall average speed of the driven shaft remains the same as that of driving shaft, and so speed ratio of the driven to the driving shaft on average is 1:1 over multiple rotations.

The angular speed ω_2 of the driven shaft, as a function of the angular speed of the driving shaft ω_1 and the angle of the driving shaft ϕ_1 , is found using:

$$\omega_2 = \omega_1 \cos\alpha / (1 - \sin^2\alpha \cdot \cos 2\theta)$$

For a given and set angle between the two shafts it can be seen that there is a cyclical variation in the input to output velocity ratio. Maximum values occur when $\sin \theta = 1$, i.e. when $\theta = 90^\circ$ and 270° . The denominator is greatest when $\theta = 0^\circ$ or 180° and this condition gives the minimum ratio of the velocities.

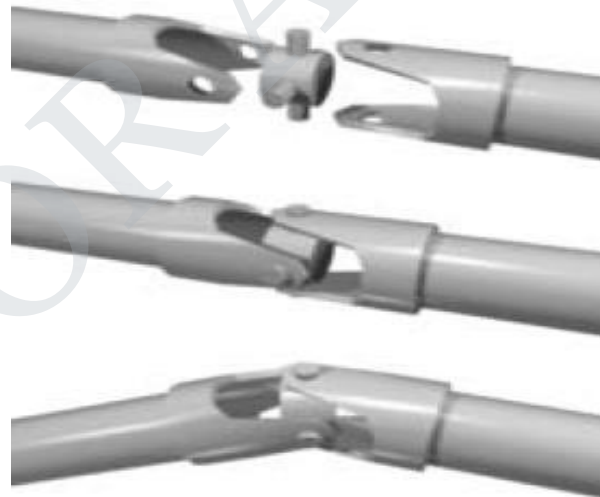
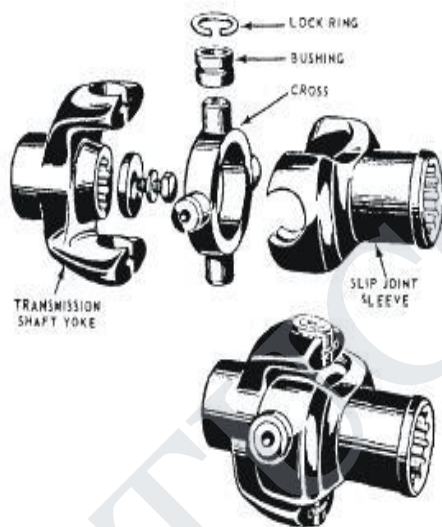
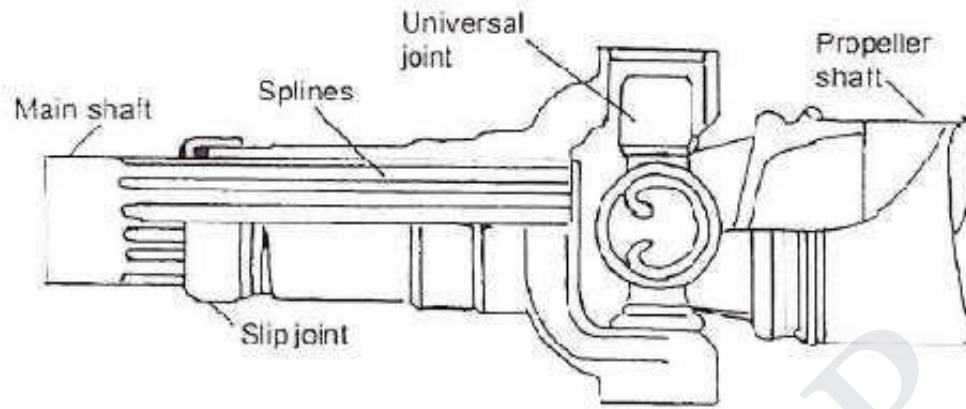

Fig: Components and assembly of U-Joint

Components of Hooke's Joint

Slip Joint in the Propeller Shaft;



Hook Joint in the Propeller Shaft;

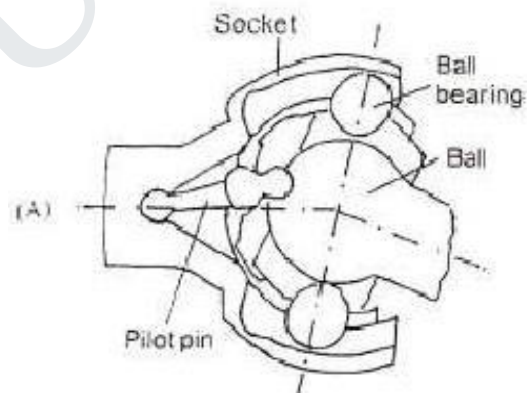
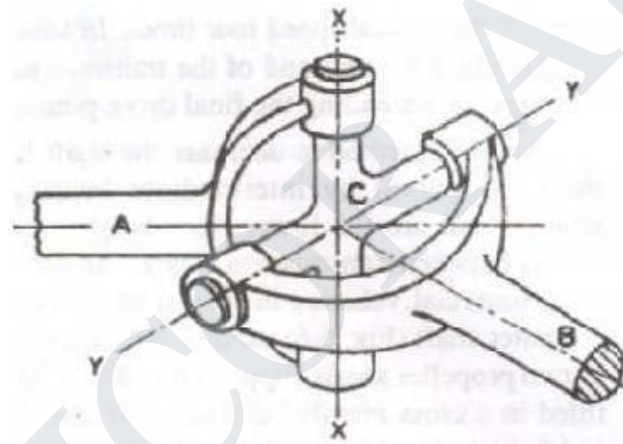

3.5. The Drive Shaft

The drive shaft, or propeller shaft, connects the transmission output shaft to the differential

pinion shaft. Since all roads are not perfectly smooth, and the transmission is fixed, the drive shaft has to be flexible to absorb the shock of bumps in the road. Universal, or "U-joints" allow the drive shaft to flex (and stop it from breaking) when the drive angle changes.

Drive shafts are usually hollow in order to weigh less, but of a large diameter so that they are strong. High quality steel, and sometimes aluminum are used in the manufacture of the drive shaft. The shaft must be quite straight and balanced to avoid vibrating. Since it usually turns at engine speeds, a lot of damage can be caused if the shaft is unbalanced, or bent. Damage can also be caused if the U-joints are worn out.

There are two types of drive shafts, the Hotchkiss drive and the Torque Tube Drive. The Hotchkiss drive is made up of a drive shaft connected to the transmission output shaft and the differential pinion gear shaft. U-joints are used in the front and rear. The Hotchkiss drive transfers the torque of the output shaft to the differential. No wheel drive thrust is sent to the drive shaft. Sometimes this drive comes in two pieces to reduce vibration and make it easier to install (in this case, three U-joints are needed). The two-piece types need ball bearings in a dustproof housing as center support for the shafts. Rubber is added into this arrangement for noise and vibration reduction.

The torque tube drive shaft is used if the drive shaft has to carry the wheel drive thrust. It is a hollow steel tube that extends from the transmission to the rear axle housing. One end is fastened to the axle housing by bolts. The transmission end is fastened with a torque ball. The drive shaft fits into the torque tube. A U-joint is located in the torque ball, and the axle housing end is splined to the pinion gear shaft. Drive thrust is sent through the torque tube to the torque ball, to transmission, to engine and finally, to the frame through the engine mounts. That is, the car is pushed forward by the torque tube pressing on the engine.

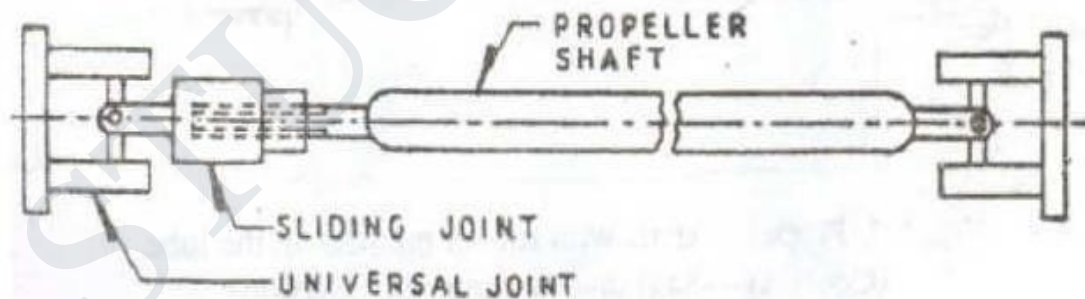

3.6. Differential Unit:

Differentials are a variety of gearbox, almost always used in one of two ways. In one of these, it receives one input and provides two outputs; this is found in every automobile. In automobile and other wheeled vehicles, the differential allows each of the driving wheels to rotate at different speeds, while supplying equal torque to each of them. In the other, less commonly encountered, it combines two inputs to create an output that is the sum (or difference) of the inputs.

In automotive applications, the differential and its housing are sometimes collectively called a "pumpkin" (because the housing resembles a pumpkin).

Purpose:-

The differential gear box has following functions:

- Avoid skidding of the rear wheels on a road turning.
- Reduces the speed of inner wheels and increases the speed of outer wheels, while drawing a curve.
- Keeps equal speeds of all the wheels while moving on a straight road.
- Eliminates a single rigid rear axle, and provides a coupling between two rear axles.

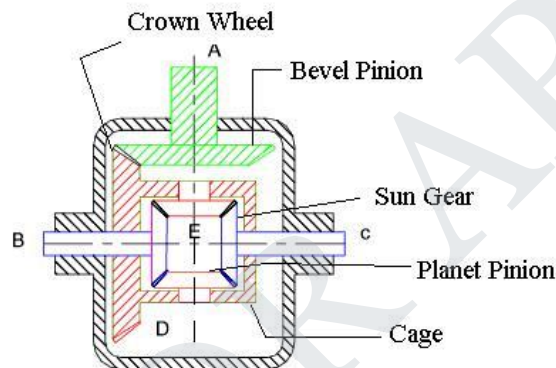

Fig: Differential gear Assembly

The following description of a differential applies to a "traditional" rear- or front-wheel-drive car or truck:

Power is supplied from the engine, via the transmission or gearbox, to a drive shaft termed as propeller shaft, which runs to the differential. A spiral bevel pinion gear at the end of the propeller shaft is encased within the differential itself, and it meshes with the large spiral bevel ring gear termed as crown wheel. The ring and pinion may mesh in hypoid orientation.

The ring gear is attached to a carrier, which holds what is sometimes called a spider, a cluster of four bevel gears in a rectangle, so each bevel gear meshes with two neighbors and rotates counter to the third that it faces and does not mesh with. Two of these spider gears are aligned on the same axis as the ring gear and drive the half shafts connected to the vehicle's driven wheels.

These are called the side gears. The other two spider gears are aligned on a perpendicular axis which changes orientation with the ring gear's rotation. These two gears are just called pinion gears, not to be confused with the main pinion gear. (Other spider designs employ different numbers of pinion gears depending on durability requirements.)

As the carrier rotates, the changing axis orientation of the pinion gears imparts the motion of the ring gear to the motion of the side gears by pushing on them rather than turning against them (that is, the same teeth stay in contact), but because the spider gears are not restricted from turning against each other, within that motion the side gears can counter-rotate relative to the ring gear and

to each other under the same force (in which case the same teeth do not stay in contact).

Thus, for example, if the car is making a turn to the right, the main ring gear may make 10 full rotations. During that time, the left wheel will make more rotations because it has further to travel, and the right wheel will make fewer rotations as it has less distance to travel. The side gears will rotate in opposite directions relative to the ring gear by, say, 2 full turns each (4 full turns relative to each other), resulting in the left wheel making 12 rotations, and the right wheel making 8 rotations.

The rotation of the ring gear is always the average of the rotations of the side gears. This is why if the wheels are lifted off the ground with the engine off, and the drive shaft is held (preventing the ring gear from turning inside the differential), manually rotating one wheel causes the other to rotate in the opposite direction by the same amount.

When the vehicle is traveling in a straight line, there will be no differential movement of the planetary system of gears other than the minute movements necessary to compensate for slight differences in wheel diameter, undulations in the road (which make for a longer or shorter wheel path), etc.

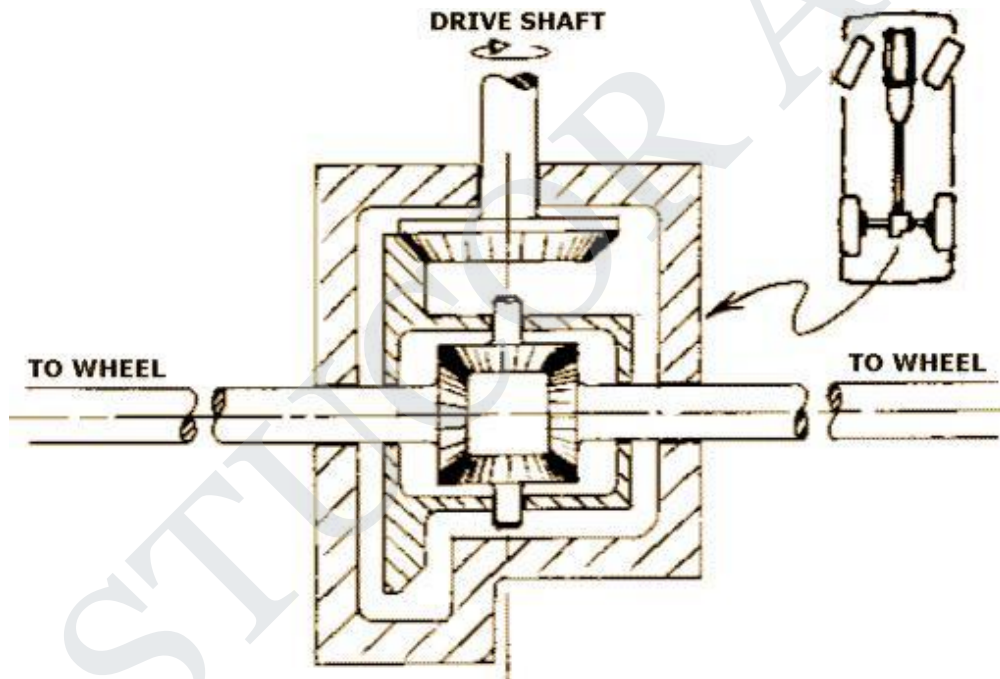

3.8. Automatic Transmission:

An automatic transmission (commonly "AT" or "Auto") is an automobile gearbox that can change gear ratios automatically as the vehicle moves, freeing the driver from having to shift gears manually.

Automatic Transmission Modes:

In order to select the mode, the driver would have to move a gear shift lever located on the steering column or on the floor next to him/her. In order to select gears/modes the driver must push a button in (called the shift lock button) or pull the handle (only on column mounted shifters) out. In some vehicles position selector buttons for each mode on the cockpit instead, freeing up space on the central console. Vehicles conforming to U.S. Government standards must have the modes ordered P-R-N-D-L (left to right, top to bottom, or clockwise). Prior to this, quadrant-selected automatic transmissions often utilized a P-N-D-L-R layout, or similar. Such a pattern led to a number of deaths and injuries owing to un-intentional gear miss-selection, as well the danger of having a selector (when worn) jump into Reverse from Low gear during engine braking maneuvers.

Automatic Transmissions have various modes depending on the model and make of the transmission. Some of the common modes are:

Park Mode (P):-

This selection mechanically locks the transmission, restricting the car from moving in any direction. A parking pawl prevents the transmission—and therefore the vehicle—from moving, although the vehicle's non-drive wheels may still spin freely. For this reason, it is recommended to use the hand brake (or parking brake) because this actually locks the (in most cases, rear) wheels and prevents them from moving. This also increases the life of the transmission and the park pin mechanism, because parking on an incline with the transmission in park without the parking brake engaged will cause undue stress on the parking pin. An efficiently-adjusted hand brake should also prevent the car from moving if a worn selector accidentally drops into reverse gear during early morning fast-idle engine warm ups.

Reverse (R):-

This puts the car into the reverse gear, giving the ability for the car to drive backwards. In order for the driver to select reverse they must come to a complete stop, push the shift lock button in (or pull the shift lever forward in the case of a column shifter) and select reverse. Not coming to a complete stop can cause severe damage to the transmission. Many modern automatic gearboxes have a safety mechanism in place, which does to some extent prevent (but doesn't completely avoid) inadvertently putting the car in reverse when the vehicle is moving.

This mechanism usually consists of a solenoid-controlled physical barrier on either side of the Reverse position, which is electronically engaged by a switch on the brake pedal. Therefore, the brake pedal needs to be depressed in order to allow the selection of reverse. Some electronic transmissions prevent or delay engagement of reverse gear altogether while the car is moving.

Neutral/No gear (N):-

This disconnects the transmission from the wheels so the car can move freely under its own weight. This is the only other selection in which the car can be started.

Drive (D):-

This allows the car to move forward and accelerate through its range of gears. The number of

gears a transmission has depends on the model, but they can commonly range from 3, 4 (the most common), 5, 6 (found in VW/Audi Direct Shift Gearbox), 7 (found in Mercedes 7G gearboxes, BMW M5 and VW/Audi Direct Shift Gearbox) and 8 in the newer models of Lexus cars. Some cars when put into D will automatically lock the doors or turn on the Daytime Running Lamps.

Overdrive ([D], Od, Or A Boxed D):-

This mode is used in some transmissions to allow early Computer Controlled Transmissions to engage the Automatic Overdrive. In these transmissions, Drive (D) locks the Automatic Overdrive off, but is identical otherwise. OD (Overdrive) in these cars is engaged under steady speeds or low acceleration at approximately 35-45 mph (approx. 72 km/h). Under hard acceleration or below 35-45 mph, the transmission will automatically downshift. Vehicles with this option should be driven in this mode unless circumstances require a lower gear.

Second (2 or S):-

This mode limits the transmission to the first two gears, or more commonly locks the transmission in second gear. This can be used to drive in adverse conditions such as snow and ice, as well as climbing or going down hills in the winter time. Some vehicles will automatically up-shift out of second gear in this mode if a certain rpm range is reached, to prevent engine damage.

First (1 or L):-

This mode locks the transmission in first gear only. It will not accelerate through any gear range. This, like second, can be used during the winter season, or for towing.

As well as the above modes there are also other modes, dependent on the manufacturer and model. Some examples include:

D5:- In Hondas and Acuras equipped with 5-speed automatic transmissions, this mode is used commonly for highway use (as stated in the manual), and uses all five forward gears.

D4:- This mode is also found in Honda and Acura 4 or 5-speed automatics and only uses the first 4 gears. According to the manual, it is used for "stop and go traffic", such as city driving.

D3:- This mode is found in Honda and Acura 4-speed automatics and only uses the first 3 gears. According to the manual, it is used for stop & go traffic, such as city driving. This mode is also found in Honda and Acura 5-speed automatics.

This is the manual selection of gears for automatics, such as Porsche's Tiptronic. This feature can also be found in Chrysler and General Motors products such as the Dodge Magnum and Pontiac G6. The driver can shift up and down at will, by toggling the shift lever (console mounted) like a semi-automatic transmission. This mode may be engaged either through a selector/position or by actually changing gear (e.g. tipping the gear-down paddles mounted near the driver's fingers on the steering wheel).

The predominant form of automatic transmission is hydraulically operated, using a fluid coupling/ torque converter and a set of planetary gear-sets to provide a range of torque multiplication.

Parts And Operation:-

A hydraulic automatic transmission consists of the following parts:

- Torque Converter/Fluid Coupling
- Planetary Gear Set
- Clutch packs & Bands
- Valve Body
- Hydraulic or Lubricating Oil

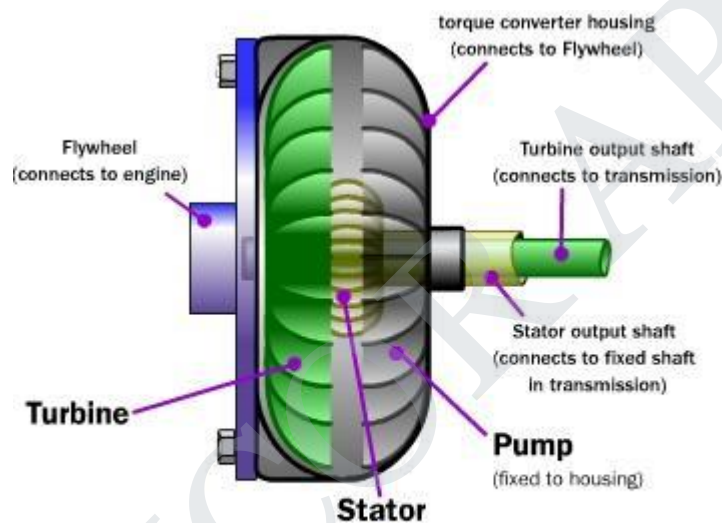

Fig: Cut section Model of Torque converter

Torque Converter/Fluid Coupling: -Unlike a manual transmission system, automatic transmission does not use a clutch to disconnect power from the engine temporarily when shifting gears. Instead, a device called a torque converter was invented to prevent power from being temporarily disconnected from the engine and also to prevent the vehicle from stalling when the transmission is in gear.

A fluid coupling/torque converter consists of a sealed chamber containing two toroidal-shaped, vaned components, the pump and turbine, immersed in fluid (usually oil). The pump or driving torus (the latter a General Motors automotive term) is rotated by the prime mover, which is typically an internal combustion engine or electric motor. The pump's motion imparts a relatively complex centripetal motion to the fluid. Simplified, this is a centrifugal force that throws the oil outwards against the coupling's housing, whose shape forces the flow in the direction of the turbine or driven torus (the latter also a General Motors term).

Here, Coriolis force reaction transfers the angular fluid momentum outward and across,

applying torque to the turbine, thus causing it to rotate in the same direction as the pump. The fluid leaving the center of the turbine returns to the pump, where the cycle endlessly repeats. The pump typically is connected to the flywheel of the engine—in fact, the coupling's enclosure may be part of the flywheel proper, and thus is turned by the engine's crankshaft. The turbine is connected to the input shaft of the transmission. As engine speed increases while the transmission is in gear, torque is transferred from the engine to the input shaft by the motion of the fluid, propelling the vehicle. In this regard, the behavior of the fluid coupling strongly resembles that of a mechanical clutch driving a manual transmission.

A torque converter differs from a fluid coupling in that it provides a variable amount of torque multiplication at low engine speeds, increasing "breakaway" acceleration. This is accomplished with a third member in the "coupling assembly" known as the stator, and by altering the shapes of the vanes inside the coupling in such a way as to curve the fluid's path into the stator. The stator captures the kinetic energy of the transmission fluid in effect using the left-over force of it to enhance torque multiplication.

Tiptronic transmission is a special type of automatic transmission with a computer controlled automatic shift. The driver can switch the transmission to manual mode, which lets her shift the gear at her wish sequentially up (+) or down (-) without disengaging the clutch. This works just like a manual transmission; however, it still uses a torque converter to transfer power from the engine. Unfortunately, this is less efficient than a manual transmission.



Fig: Torque converter

Planetary Gear-Set: - The automatic system for current automobiles uses a planetary gear set instead of the traditional manual transmission gear set. The planetary gear set contains four parts: sun gear, planet gears, planet carrier, and ring gear. Based on this planetary set design, sun gear, planet carrier, and ring gear spin centrifugally. By locking one of them, the planetary set can generate three different gear ratios, including one reverse gear, without engaging and disengaging the gear set. The gear set is actuated by hydraulic servos controlled by the valve body, providing two or more gear ratios.

Clutch Packs And Bands: - A clutch pack consists of alternating disks that fit inside a clutch

drum. Half of the disks are steel and have splines that fit into grooves on the inside of the drum.

The other half have a friction material bonded to their surface and have splines on the inside edge that fit grooves on the outer surface of the adjoining hub. There is a piston inside the drum that is activated by oil pressure at the appropriate time to squeeze the clutch pack together so that the two components become locked and turn as one.

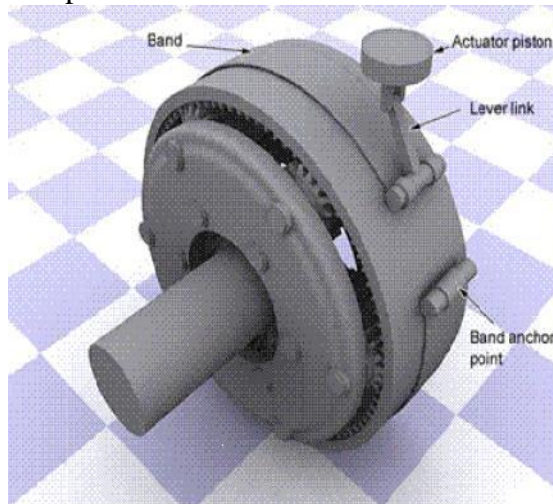

Figure 12: The structure of the actuator piston, lever link, and band system.

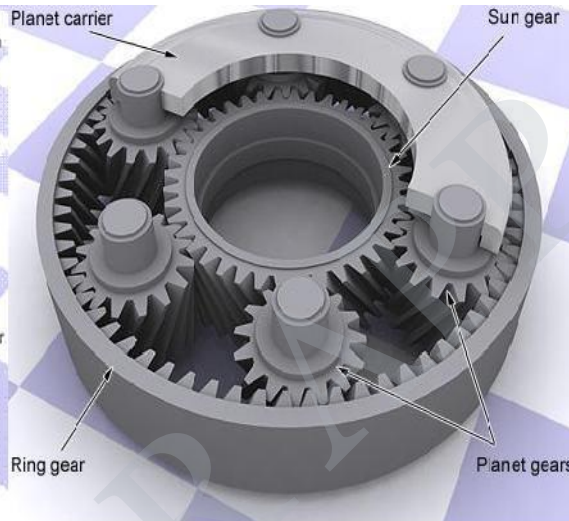

Figure 10 Planetary Gear Set.

A band is a steel strap with friction material bonded to the inside surface. One end of the band is anchored against the transmission case while the other end is connected to a servo. At the appropriate time hydraulic oil is sent to the servo under pressure to tighten the band around the drum to stop the drum from turning.

The bands come into play for manually selected gears, such as low range or reverse, and operate on the planetary drum's circumference. Bands are not applied when drive/overdrive range is selected, the torque being transmitted by the sprag clutches instead.

The sun gear is connected to a drum, which can be locked by a band. The ring gear is directly connected to the input shaft, which transfers power from the engine. The planet carrier is connected to the output shaft, which transfers power into the wheels.

Based on this design, when in neutral, both band and clutch sets are released. Turning the ring gear can only drive planet gears but not the planet carrier, which stays static if the car is not moving. The planet gears drive the sun gear to spin freely. In this situation, the input shaft is not able to transfer power to the output shaft. When shifting to 1st gear, the band locks the sun gear by locking the drum. The ring gear drives the planet carrier to spin. In this situation, the ring gear (input shaft) spins faster than the planet carrier (output shaft).

To shift to higher gear, the band is released and the clutch is engaged to force the sun gear

and planet carrier (output shaft) to spin at the same speed. The input shaft will also spin at the same speed as the output shaft, which makes the car run faster than in 1st gear. Using a compound planetary gear set generates more gear ratios with a special gear ratio, over-drive gear whose gear ratio is small than 1.

This will make the gear shift smoother. Both the band and clutch piston are pressurized by the hydraulic system. The part connecting the band or clutches to the hydraulic system is called the shift valve, while the one connecting the hydraulic system to the output shaft is called the governor.

The governor is a centrifugal sensor with a spring loaded valve. The faster the governor spins, the more the valve opens. The more the valve opens, the more the fluid goes through and the higher the pressure applied on the shift valve. Therefore, each band and clutch can be pushed to lock the gear based on a specific spin speed detected by the governor from the output shaft. To make the hydraulic system work efficiently, a complex maze of passages was designed to replace a large number of tubes. For modern cars, an electronic con-trolled (computer controlled) solenoid pack is used to detect throttle position, vehicle speed, engine speed, engine load, brake pedal position, etc., and to automatically choose the best gear for a moving vehicle.

Principally, a type of device known as a sprag or roller clutch is used for routine upshifts/downshifts. Operating much as a ratchet, it transmits torque only in one direction, freewheeling or "overrunning" in the other. The advantage of this type of clutch is that it eliminates the sensitivity of timing a simultaneous clutch release/apply on two planetaries, simply "taking up" the drivetrain load when actuated, and releasing automatically when the next gear's sprag clutch assumes the torque transfer.

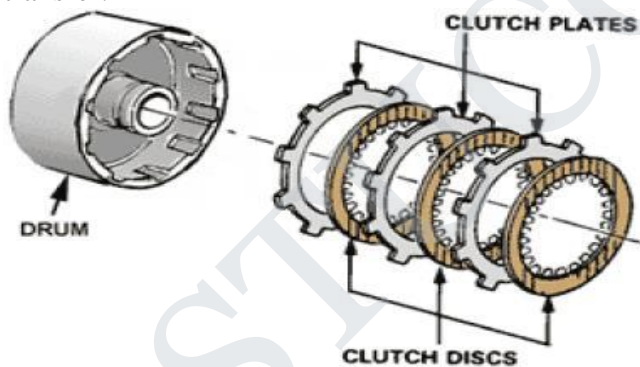

Fig: CLUTCH PACKS

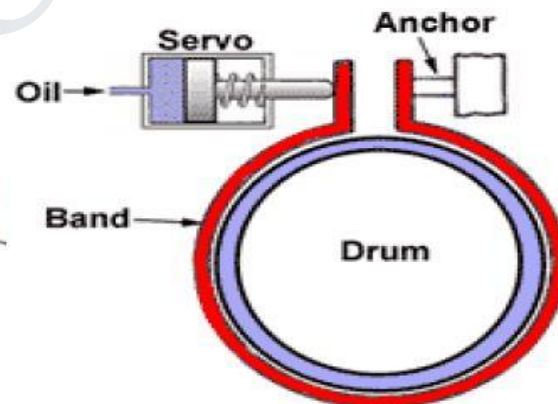

Fig: BANDS

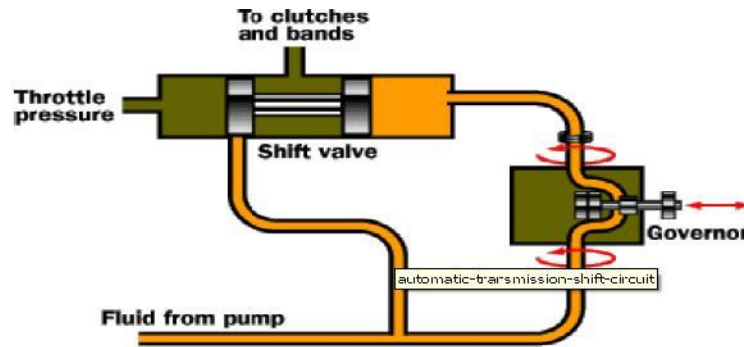

Fig: Hydraulic System

Valve Body: - Hydraulic control center that receives pressurized fluid from a main pump operated by the fluid coupling/torque converter. The pressure coming from this pump is regulated and used to run a network of spring-loaded valves, check balls and servo pistons.

The valves use the pump pressure and the pressure from a centrifugal governor on the output side (as well as hydraulic signals from the range selector valves and the throttle valve or modulator) to control which ratio is selected on the gearset; as the car and engine change speed, the difference between the pressures changes, causing different sets of valves to open and close.

Each of the many valves in the valve body has a specific purpose and is named for that function. For example the 2-3 shift valves activate the 2nd gear to 3rd gear up-shift or the 3-2 shift timing valve which determines when a downshift should occur.

The hydraulic pressure controlled by these valves drives the various clutch and brake band actuators, thereby controlling the operation of the planetary gearset to select the optimum gear ratio for the current operating conditions. However, in many modern automatic transmissions, the valves are controlled by electro-mechanical servos which are controlled by the Engine Management System or a separate transmission controller.

The most important valve and the one that you have direct control over is the manual valve. The manual valve is directly connected to the gear shift handle and covers and uncovers various passages depending on what position the gear shift is placed in. When you place the gear shift in Drive, for instance, the manual valve directs fluid to the clutch pack(s) that activates 1st gear.

It also sets up to monitor vehicle speed and throttle position so that it can determine the optimal time and the force for the 1 - 2 shifts. On computer controlled transmissions, you will also have electrical solenoids that are mounted in the valve body to direct fluid to the appropriate clutch packs or bands under computer control to more precisely control shift points.

Hydraulic & Lubricating Oil: - A component called Automatic Transmission Fluid (ATF) which is part of the transmission mechanism provides lubrication, corrosion prevention, and a hydraulic medium to convey mechanical power.

Primarily it is made of refined petroleum and processed to provide properties that promote smooth power transmission and increase service life. ATF is one of the parts of the automatic transmission that needs routine service as the vehicle ages.

3.9. Semi Automatic Transmission

A semi-automatic transmission (also known as clutch less manual transmission, automated manual transmission, e-gear, shift-tronic, flappy paddle gearbox, or paddle shift gearbox) is a system which uses electronic sensors, processors and actuators to do gear shifts on the command of the driver. This removes the need for a clutch pedal which the driver otherwise needs to depress before making a gear change, since the clutch itself is actuated by electronic equipment which can synchronize the timing and torque required to make gear shifts quick and smooth.

The system was designed by European automobile manufacturers to provide a better driving experience, especially in cities where congestion frequently causes stop-and-go traffic patterns. Like a tiptronic transmission, a semi-automatic transmission can also be switched to manual mode to perform gear shifting at the drivers wish.

The two most common semi-automatic transmissions

- Direct shift transmission (or dual-clutch transmission)
- Electro-hydraulic manual transmission (or sequential transmission)

Direct shift transmission: In direct shift transmission direct shift gear box is used. The Direct-Shift Gearbox or D.S.G. is an electronically controlled, twin-shaft dual-clutch manual gearbox, without a conventional clutch pedal, with full automatic or semi-manual control.

Unlike the conventional manual transmission system, there are two different gear/collar sets, with each connected to two different input/output shafts. The outer clutch pack drives gears 1, 3, 5 and reverse. It is just like two conventional manual transmission gear boxes in one. The inner clutch pack drives gears 2, 4, and 6. Instead of a standard large dry single-plate clutch, each clutch pack is a collection of four small wet interleaved clutch plates.

Due to space constraints, the two clutch assemblies are concentric. To automatically shift from 1st gear to 2nd gear, first the computer detects that the spinning speed of the input shaft is too high, and engages the 2nd gear's collar to the 2nd gear. The clutch then disengages from 1st gear's input shaft, and engages the 2nd gear's input shaft. Controlled by computer, the gear shift becomes extremely fast compared with a conventional manual transmission.

Using direct contact of the clutch instead of fluid coupling also improves power transmission efficiency. Another advanced technology used for direct shift trans-mission allows it to perform "double clutching" by shifting the gear to neutral first, adjusting the spinning speed of the input shaft, and then shifting to the next gear. This makes gear shifting very smooth.

Operation Modes Of D.S.G.:- "D" mode:

When the motor vehicle is stationary, in neutral, both clutch packs are fully disengaged. When the driver has selected D for drive (after pressing the foot brake pedal), the transmission's first

gear is selected on the first shaft, and the clutch prepares to engage. At the same time, the second gear is also selected, but the clutch pack for second gear remains fully disengaged. When the driver releases the brake pedal, the clutch pack for the first gear takes up the drive, and the vehicle moves forward. Pressing the accelerator pedal increases forward speed. As the car accelerates, the transmission's computer determines when the second gear (which is connected to the second clutch) should be fully utilized.

Depending on the vehicle speed and amount of power being requested by the driver (full throttle or part-throttle normal driving), the D.S.G. then up-shifts. During this sequence, the DSG disengages the first clutch while engaging the second clutch (all power from the engine is now going through the second shaft), thus completing the shift sequence. This sequence happens in 8 ms, and there is practically no power loss.

Once the vehicle has shifted up to second gear, the first gear is immediately de-selected, and third gear (being on the same shaft as 1st and 5th) is pre-selected, and is pending. Once the time comes to shift, the second clutch disengages and the first clutch re-engages. This method of operation continues in the same manner up to 6th gear. Down shifting is similar to up-shifting but in reverse order. The car's computer senses the car slowing down or more power required, and thus lines up a lower gear on one of the shafts not in use, and then completes the downshift.

The actual shift timings are determined by the D.S.G.'s Electronic Control Unit, or E.C.U., which commands a hydro-mechanical unit, and the two units combined are called a "mechatronics" unit. Because the D.S.G. & E.C.U. uses "fuzzy logic", the operation of the DSG is said to be "adaptive"; i.e. the DSG will "learn" how the user drives the car, and will tailor the shift points accordingly.

In the vehicle instrument display, between the speedometer and tachometer, the available shift positions are shown, the current position of the shift lever is highlighted, and the current gear ratio is also displayed as a number. Under "normal", progressive acceleration and deceleration, the DSG shifts in a "sequential" mode, i.e. under acceleration: 1 > 2 > 3 > 4 > 5 > 6, and the same sequence reversed for deceleration. However, if the car is being driven at sedate speeds, with a light throttle opening, and the accelerator pedal is then pressed fully to the floor, this activates the "kick-down" function. During kick-down, the DSG can skip gears, going from 6th gear straight down to 3rd gear.

"S" mode:

The floor selector lever also has an S position. When S is selected, "sport" mode is activated in the DSG. Sport mode still functions as a fully automatic mode, identical in operation to "D" mode, but up-shifts and down-shifts are made much higher up the engine rev-range. This aids a sportier driving manner, by utilizing considerably more of the available engine power, and also

maximizing engine braking. However, this mode does have a worsening effect on the vehicle fuel consumption, when compared to D mode. S is also highlighted in the instrument display, and like D mode, the currently used gear ratio is displayed as a number.

Manual (Tiptronic) Mode:

Additionally, the floor shift lever also has another plane of operation, for manual or tiptronic mode, with spring-loaded "+" and "-" positions. This plane is selected by moving the stick away from the driver (in vehicles with the drivers seat on the right, the lever is pushed to the left, and in left-hand drive cars, the stick is pushed to the right) when in "D" mode only. When this plane is selected, the D.S.G. can now be controlled like a manual gearbox, even though under a sequential shift pattern.

The readout in the instrument display changes to 6 -5- 4- 3- 2- 1, and just like the automatic modes, the currently used gear ratio is highlighted. To change up a gear, the lever is pushed forwards (against a spring pressure) towards the "+", and to change down, the lever is pulled rearwards towards the "-".

The DSG box can now be operated with the gear changes being (primarily) determined by the driver. This method of operation is commonly called "tiptronic". When accelerating in Manual/tiptronic mode, the D.S.G. will still automatically change up just before the red-line and when decelerating, it will change down automatically at very low revs, just before the engine idle speed (tick over). Furthermore, if the driver calls for a gear when it is not appropriate (i.e., engine speed near the red-line, and a down change is requested) the D.S.G. will delay the change until the engine revs are at an appropriate level to cope with the requested gear.

Paddle Shifters:

On certain "sporty" or high-powered cars paddle shifters are available. The paddle shifters have two distinct advantages: the driver can safely keep both hands on the steering wheel when using the Manual/tiptronic mode; and the driver can immediately manually override either of the automatic programs (D or S) on a temporary basis, and gain instant manual control of the D.S.G. box.

If the manual override of one of the automatic programs (D or S) is utilized intermittently, the gearbox will "default" back to the previously selected automatic mode after a predetermined duration of inactivity of the paddles, or when the car becomes stationary. Alternatively, should the driver wish to revert immediately to automatic control, this can be done by holding the "+" paddle for at least two seconds.

Electro Hydraulic Manual Transmission:

In electro-hydraulic manual transmission (also known as sequential transmission) the gear set is almost the same as the conventional transmission system, except that the shifting of the selector is not an "H" pattern. Instead, all selector forks are connected to a drum. The drum has several grooves, and each has a ball sliding in it. Each fork hooks up to a ball and can be moved forward and backward when the drum is turning. Based on the pattern of the grooves on the drum, by turning the drum, each fork can move forward and backward in turn, which makes gear selection sequential.

Therefore, it is impossible for an electro-hydraulic manual transmission to perform a gear shift from 1st to 3rd or 4th to 2nd. The shifting must be sequential, like 1st → 2nd → 3rd → 4th, or 4th → 3rd → 2nd → 1st.

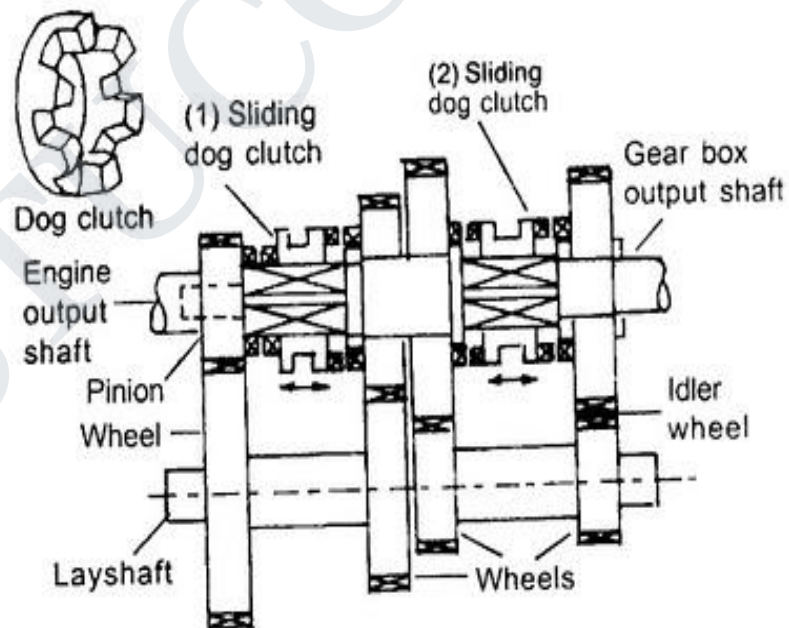
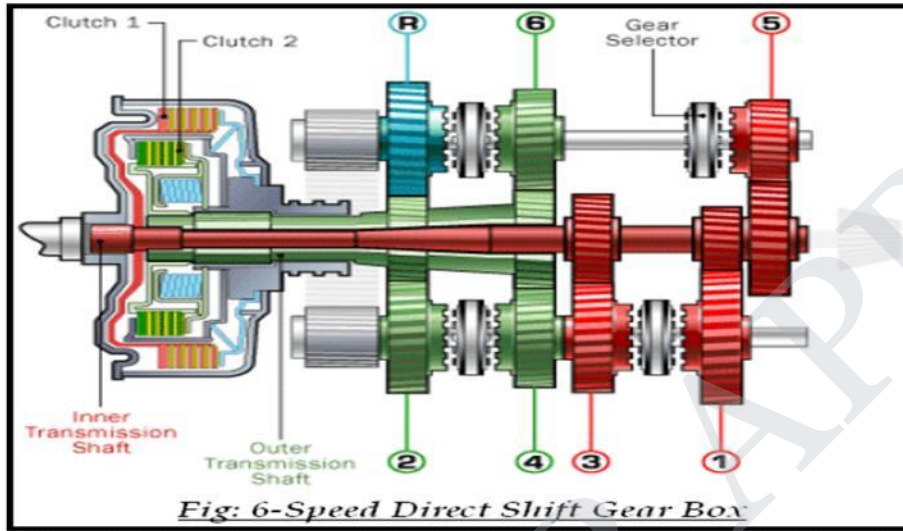

3.10.1. Hotchkiss drive;

The Hotchkiss drive is a system of power transmission. It was the dominant form of power transmission for front-engine, rear-wheel drive layout cars in the 20th century. The name comes from the French automobile firm of Hotchkiss, although it is clear that other makers (such as Peerless) used similar systems before Hotchkiss.

During the early part of the 20th century the two major competing systems of power transmission were the shaft-drive and chain-drive configurations. The Hotchkiss drive is a shaft-drive system (another type of direct-drive transmission system is the torque tube, which was also popular until the 1950s).

All shaft-drive systems consist of a driveshaft (also called a "propeller shaft" or Cardan shaft) extending from the transmission in front to the differential in the rear. The differentiating characteristic of the Hotchkiss drive is the fact that it uses universal joints at *both* ends of the driveshaft, which is not enclosed. The use of two universal joints, properly phased and with parallel alignment of the drive and driven shafts, allows the use of simple cross-type universals. (In a torque-tube arrangement only a single universal is used at the end of the transmission tail shaft, and this universal should be a constant velocity joint.)

In the Hotchkiss drive, slip-splines or a plunge-type (ball and trunnion u-joint) eliminate thrust transmitted back up the driveshaft from the axle, allowing simple rear-axle positioning using parallel leaf springs. (In the torque-tube type this thrust is taken by the torque tube to the transmission and thence to the transmission and motor mounts to the frame. While the torque-tube type requires additional locating elements, such as a Panhard rod, this allows the use of coil springs.)

Some Hotchkiss drive shafts are made in two pieces with another universal joint in the center for greater flexibility, typically in trucks and specialty vehicles built on truck frames. Some installations use rubber mounts to isolate noise and vibration. The 1984–1987 RWD Toyota Corolla (i.e., Corolla SR5 and GT-S) coupe is another example of a car that uses a 2-part Hotchkiss driveshaft with a rubber-mounted center bearing.

This design was the main form of power transmission for most cars from the 1920s through the 1970s. Presently (circa 2012), it remains common in pick-up trucks, and sport utility vehicles.

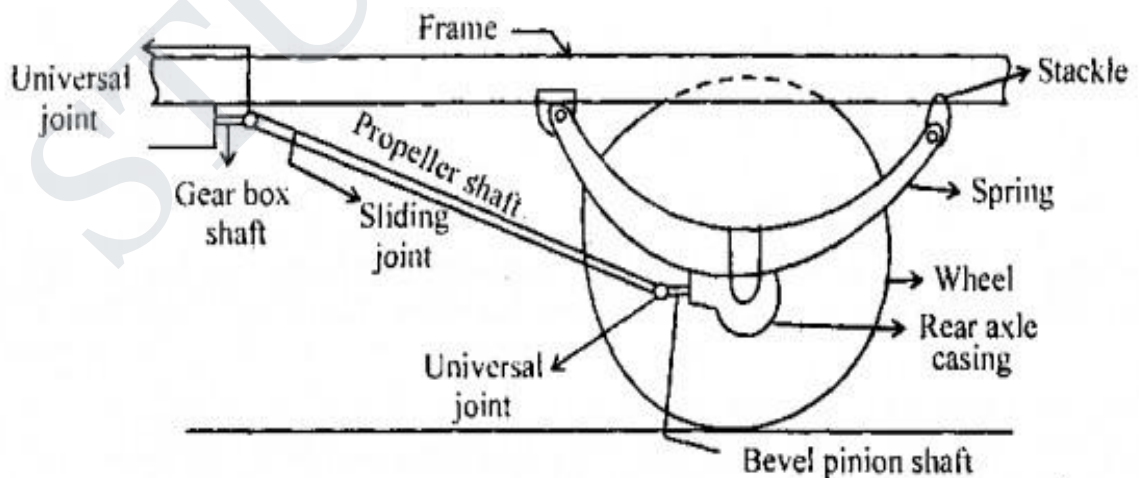

3.10.2. Torque tube Drive

A torque tube system is a driveshaft technology, often used in automobiles with a front engine and rear drive. It is not as widespread as the Hotchkiss drive, but is still occasionally used to this day. Drive shafts are sometimes also used for other vehicles and machinery.

The "torque" that is referred to in the name is not that of the driveshaft, along the axis of the car, but that applied by the wheels. The design problem that the torque tube solves is how to get the traction forces generated by the wheels to the car frame. The "torque tube" transmits this force by directly coupling the axle differential to the transmission and therefore propels the car forward by pushing on the engine/transmission and then through the engine mounts to the car frame^[citation needed].

In contrast, the Hotchkiss drive has the traction forces transmitted to the car frame by using other suspension components such as leaf springs or trailing arms. A ball and socket type of joint called a "torque ball" is used at one end of the torque tube to allow relative motion between the axle and transmission due to suspension travel. Since the torque tube does not constrain the axle in the lateral (side-to-side) direction a pan hard rod is often used for this purpose. The combination of the pan hard rod and the torque tube allows the easy implementation of soft coil springs in the rear to give good ride quality.

In addition to transmitting the traction forces, the torque tube is hollow and contains the rotating driveshaft. Inside the hollow torque ball is the universal joint of the driveshaft that allows relative motion between the two ends of the driveshaft. In most applications the drive shaft uses a single universal joint which has the disadvantage that it causes speed fluctuations in the driveshaft when the shaft is not straight. The Hotchkiss drive uses two universal joints which has the effect of canceling the speed fluctuations and gives a constant speed even when the shaft is no longer straight.

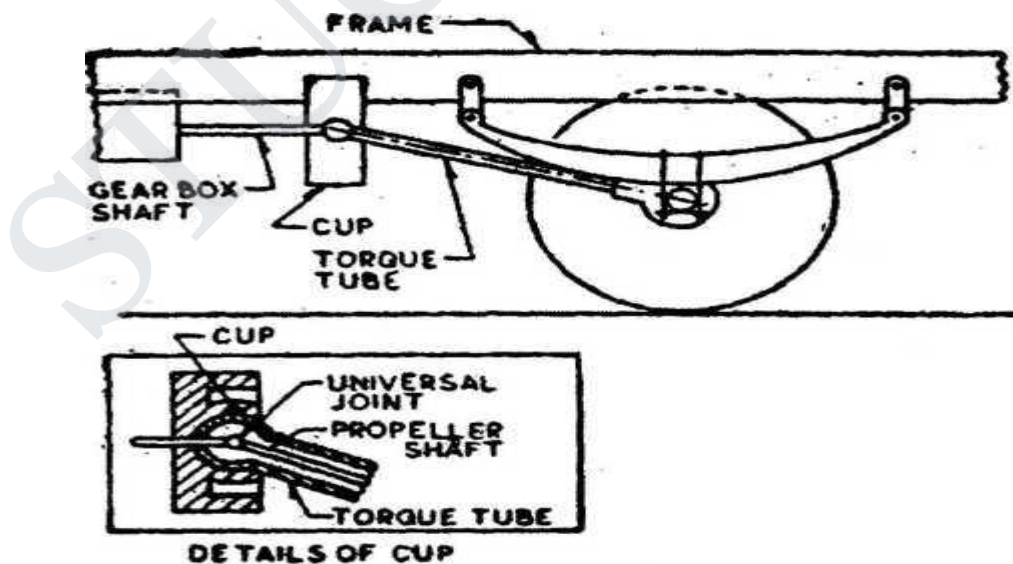

UNIT-IV STEERING.
BRAKES
AND SUSPENSION SYSTEMS

4.1. Introduction of Steering system

Steering is the collection of components, linkages, etc. which allow a vessel (ship,boat) or vehicle (car, motorcycle, bicycle) to follow the desired course. An exception is the case of rail transport by which rail tracks combined together with railroad switches (and also known as 'points' in British English) provide the steering function.

The most conventional steering arrangement is to turn the front wheels using a hand-operated steering wheel which is positioned in front of the driver, via the steering column, which may contain universal joints (which may also be part of the collapsible steering column design), to allow it to deviate somewhat from a straight line. Other arrangements are sometimes found on different types of vehicles, for example, a tiller or rear-wheel steering. Tracked vehicles such as bulldozers and tanks usually employ differential steering — that is, the tracks are made to move at different speeds or even in opposite directions, using clutches and brakes, to bring about a change of course or direction.

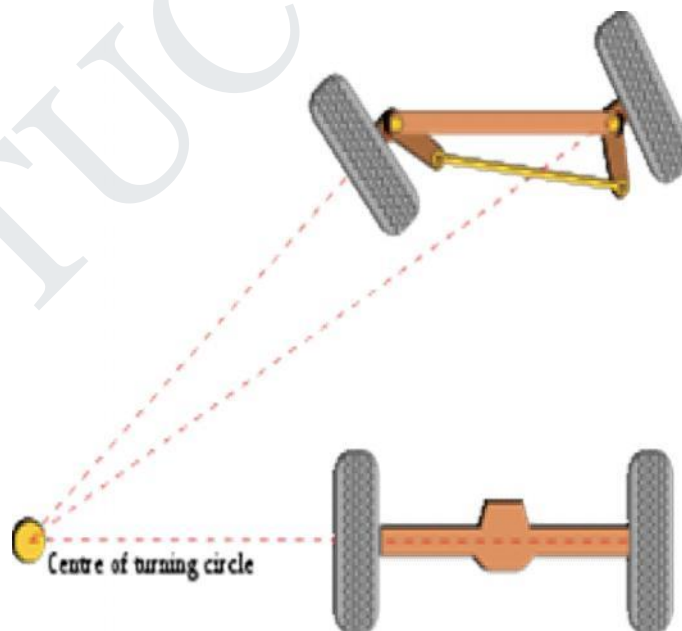

4.2. Ackermann steering geometry

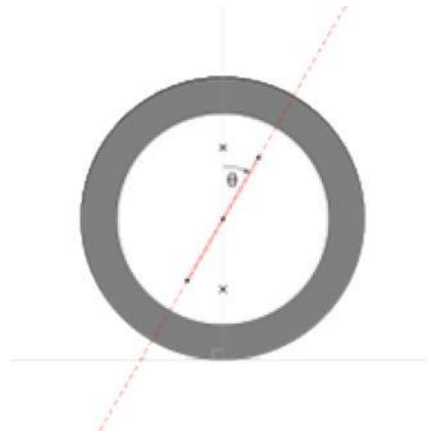

Caster angle θ indicates kingpin pivot line and gray area indicates vehicle's tire with the wheel moving from right to left. A positive caster angle aids in directional stability, as the wheel tends to trail, but a large angle makes steering more difficult.

Curves described by the rear wheels of a conventional automobile. While the vehicle moves with a constant speed its inner and outer rear wheels do not.

The basic aim of steering is to ensure that the wheels are pointing in the desired directions. This is typically achieved by a series of linkages, rods, pivots and gears. One of the fundamental concepts is that of caster angle – each wheel is steered with a pivot point ahead of the wheel; this makes the steering tend to be self-centering towards the direction of travel.

The steering linkages connecting the steering box and the wheels usually conform to a variation of Ackermann steering geometry, to account for the fact that in a turn, the inner wheel is actually travelling a path of smaller radius than the outer wheel, so that the degree of toe suitable for driving in a straight path is not suitable for turns. The angle the wheels make with the vertical plane also influences steering dynamics (see camber angle) as do the tires.

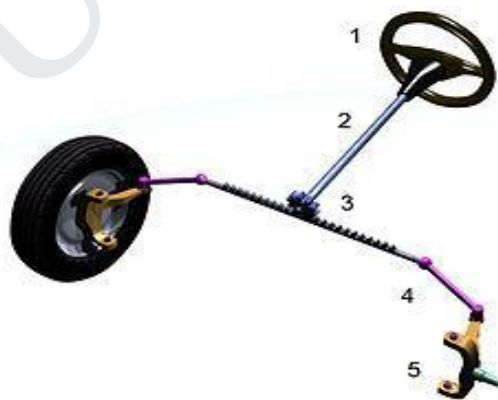

Rack and pinion, recirculating ball, worm and sector

Rack and pinion steering mechanism:

1. Steering wheel;
2. Steering column;
3. Rack and pinion;
4. Tie rod;
5. Kingpin

Rack and pinion unit mounted in the cockpit of an Ariel Atom sports car chassis. For most high volume production, this is usually mounted on the other side of this panel

Steering box of a motor vehicle, the traditional (non-assisted), you may notice that the system allows you to adjust the braking and steering systems, you can also see the attachment system to the frame.

Many modern cars use rack and pinion steering mechanisms, where the steering wheel turns the pinion gear; the pinion moves the rack, which is a linear gear that meshes with the pinion, converting circular motion into linear motion along the transverse axis of the car (side to side motion). This motion applies steering torque to the swivel pin ball joints that replaced previously used kingpins of the stub axle of the steered wheels via tie rods and a short lever arm called the steering arm.

The rack and pinion design has the advantages of a large degree of feedback and direct steering "feel". A disadvantage is that it is not adjustable, so that when it does wear and develop lash, the only cure is replacement.

Older designs often use the recirculating ball mechanism, which is still found on trucks and utility vehicles. This is a variation on the older sector design; the steering column turns a large screw (the "worm gear") which meshes with a sector of a gear, causing it to rotate about its axis as the worm gear is turned; an arm attached to the axis of the sector moves the Pitman arm, which is connected to the steering linkage and thus steers the wheels. The recirculating ball version of this apparatus reduces the considerable friction by placing large ball bearings between the teeth of the worm and those of the screw; at either end of the apparatus the balls exit from between the two pieces into a channel internal to the box which connects them with the other end of the apparatus, thus they are "recalculated".

The recirculating ball mechanism has the advantage of a much greater mechanical advantage, so that it was found on larger, heavier vehicles while the rack and pinion was originally limited to smaller and lighter ones; due to the almost universal adoption of power steering, however, this is no longer an important advantage, leading to the increasing use of rack and pinion on newer cars.

The recirculating ball design also has a perceptible lash, or "dead spot" on center, where a minute turn of the steering wheel in either direction does not move the steering apparatus; this is easily adjustable via a screw on the end of the steering box to account for wear, but it cannot be entirely eliminated because it will create excessive internal forces at other positions and the mechanism will wear very rapidly. This design is still in use in trucks and other large vehicles, where rapidity of steering and direct feel are less important than robustness, maintainability, and mechanical advantage.

The worm and sector was an older design, used for example in Willys and Chrysler vehicles, and the Ford Falcon (1960s).

Other systems for steering exist, but are uncommon on road vehicles. Children's toys and go-karts often use a very direct linkage in the form of abellcrank (also commonly known as a Pitman arm) attached directly between the steering column and the steering arms, and the use of cable-operated steering linkages (e.g. the Capstan and Bowstring mechanism) is also found on some home-built vehicles such as soapbox cars and recumbent tricycles.

4.3. Steering Gear Boxes;

The steering gears converts the rotary motion of the steering wheel into the to-and-fro motion of the link rod of the steering linkages. Moreover it also provides necessary leverage so that the driver is able to steer the vehicle without fatigue.

There are various types of steering gear boxes are available in automobile.

- Worm and Wheel steering gear box,
- Cam and double roller steering gear box,
- Worm and nut steering gear box,
- Recalculating ball type steering gear box,
- Rack and pinion steering gear box,

4.4. Power steering

In automobiles, power steering (also known as power assisted steering (PAS) or steering assist system) helps drivers steer by augmenting steering effort of the steering wheel.

Hydraulic or electric actuators add controlled energy to the steering mechanism, so the driver needs to provide only modest effort regardless of conditions. Power steering helps considerably when a vehicle is stopped or moving slowly. Also, power steering provides some feedback of forces acting on the front wheels to give an ongoing sense of how the wheels are interacting with the road; this is typically called "road feel".

Representative power steering systems for cars augment steering effort via an actuator, a hydraulic cylinder, which is part of a servo system. These systems have a direct mechanical

connection between the steering wheel and the linkage that steers the wheels.

This means that power-steering system failure (to augment effort) still permits the vehicle to be steered using manual effort alone.

Other power steering systems (such as those in the largest off-road construction vehicles) have no direct mechanical connection to the steering linkage; they require power. Systems of this kind, with no mechanical connection, are sometimes called "drive by wire" or "steer by wire", by analogy with aviation's "fly-by-wire". In this context, "wire" refers to electrical cables that carry power and data, not thin-wire-rope mechanical control cables.

In other power steering systems, electric motors provide the assistance instead of hydraulic systems. As with hydraulic types, power to the actuator (motor, in this case) is controlled by the rest of the power-steering system.

Some construction vehicles have a two-part frame with a rugged hinge in the middle; this hinge allows the front and rear axles to become non-parallel to steer the vehicle. Opposing hydraulic cylinders move the halves of the frame relative to each other to steer.

Power steering helps the driver of a vehicle to steer by directing some of the power to assist in swiveling the steered road wheels about their steering axes. As vehicles have become heavier and switched to front wheel drive, particularly using negative offset geometry, along with increases in tire width and diameter, the effort needed to turn the wheels about their steering axis has increased, often to the point where major physical exertion would be needed were it not for power assistance.

To alleviate this auto makers have developed power steering systems: or more correctly power-assisted steering—on road going vehicles there has to be a mechanical linkage as a failsafe. There are two types of power steering systems; hydraulic and electric/electronic. A hydraulic-electric hybrid system is also possible. A hydraulic power steering (HPS) uses hydraulic pressure supplied by an engine-driven pump to assist the motion of turning the steering wheel. Electric power steering (EPS) is more efficient than the hydraulic power steering, since the electric power steering motor only needs to provide assistance when the steering wheel is turned, whereas the hydraulic pump must run constantly.

In EPS, the amount of assistance is easily tunable to the vehicle type, road speed, and even driver preference. An added benefit is the elimination of environmental hazard posed by leakage and disposal of hydraulic power steering fluid. In addition, electrical assistance is not lost when the engine fails or stalls, whereas hydraulic assistance stops working if the engine stops, making the steering doubly heavy as the driver must now turn not only the very heavy steering—without any help—but also the power-assistance system itself.

Speed Sensitive Steering

An outgrowth of power steering is speed sensitive steering, where the steering is heavily assisted at low speed and lightly assisted at high speed. The auto makers perceive that motorists might need to make large steering inputs while manoeuvring for parking, but not while traveling at high speed. The first vehicle with this feature was the Citroën SM with its Diravi layout[citation needed], although rather than altering the amount of assistance as in modern power steering systems,

FIG. 1

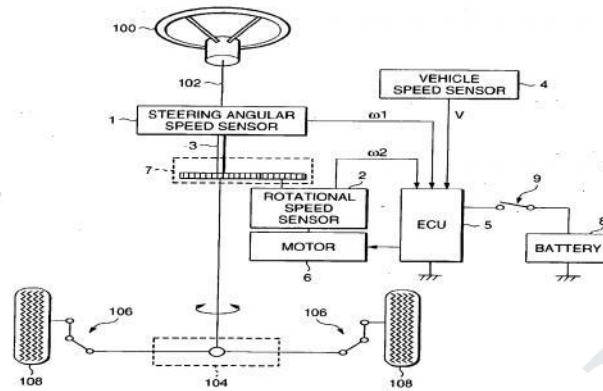

it altered the pressure on a centring cam which made the steering wheel try to "spring" back to the straight-ahead position. Modern speed-sensitive power steering systems reduce the mechanical or electrical assistance as the vehicle speed increases, giving a more direct feel. This feature is gradually becoming more common.

4.5. Suspension system;

Suspension system is the term given to the system of springs, shock absorbers and linkages that connects a vehicle to its wheels. It is basically cushion for passengers protects the luggage or any cargo and also itself from damage and wear.

Sir **William Brush** is the father of suspension system in automobiles.

The main role of suspension system are as follows:

- It supports the weight of vehicle .
- Provides smoother ride for the driver and passengers i.e. acts as cushion.
- Protects your vehicle from damage and wear .
- It also plays a critical role in maintaining self driving conditions.
- It also keeps the wheels pressed firmly to the ground for traction .
- It isolates the body from road shocks and vibrations which would otherwise be transferred to the passengers and load.

Principle :

When a tire hits an obstruction, there is a reaction force. The size of this reaction force depends on the unsprung mass at each wheel assembly.

In general, the larger the ratio of sprung weight to unsprung weight, the less the body and vehicle occupants are affected by bumps, dips, and other surface imperfections such as small

bridges. A large sprung weight to unsprung weight ratio can also impact vehicle control.

No road is perfectly flat i.e. without irregularities. Even a freshly paved highways have subtle imperfections that can be interact with vehicle's wheels. These are the imperfections that apply forces on wheels.

According to **Newton 's law of motion** all forces have both magnitude and direction. A bump in the road causes the wheel to move up and down perpendicular to the road surface. The magnitude of course ,depends on whether the wheel is striking a giant bump or a tiny speck. Thus, either the wheel experiences a vertical acceleration as it passes over an imperfection.

The suspension of a car is actually part of the chassis, which comprises all of the important systems located beneath the car's body. These system include :

- Frame
- Suspension system
- Steering system
- Tires or Wheels

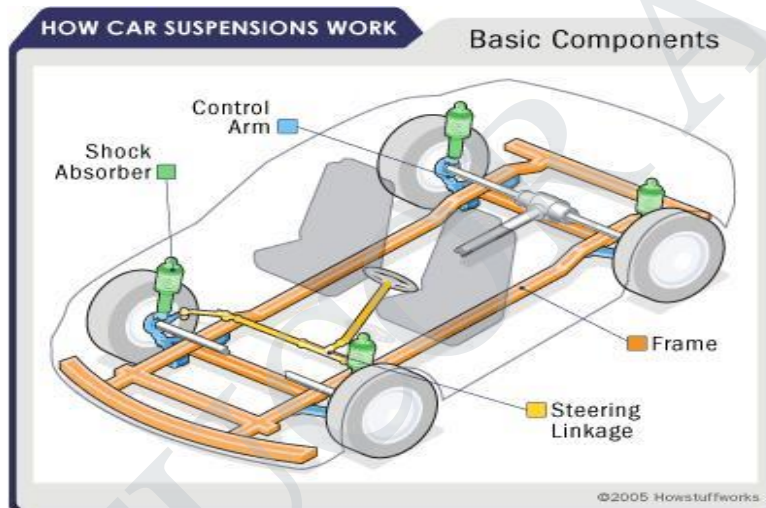

Components of Suspension system;

There are three fundamental components of any suspension system .

- Springs
 - Coil spring
 - Leaf springs
 - Air springs
- Dampers
 - Shock Absorbers
 - Struts:-
 - Anti-sway Bars
- Anti sway bars.

Types of Suspension system;

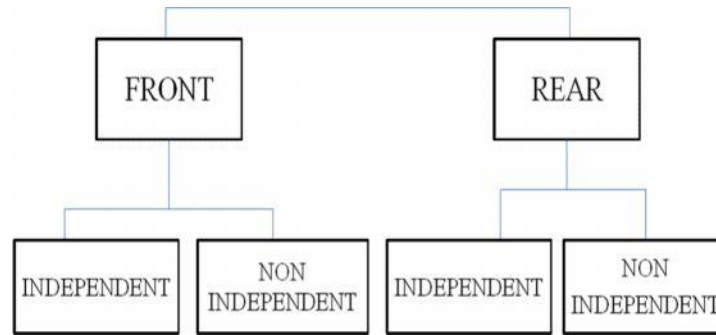

Advantages;

- Comfort to passengers
- Good handling
- Shields the vehicle from damage
- Increases life of vehicle
- Keeps the tires pressed firmly to ground.

4.6. Braking System;

A brake is a mechanical device which inhibits motion, slowing or stopping a moving object or preventing its motion. The rest of this article is dedicated to various types of vehicular brakes.

Most commonly brakes use friction between two surfaces pressed together to convert the kinetic energy of the moving object into heat, though other methods of energy conversion may be employed. For example regenerative braking converts much of the energy to electrical energy, which may be stored for later use. Other methods convert kinetic energy into potential energy in such stored forms as pressurized air or pressurized oil. Eddy current brakes use magnetic fields to convert kinetic energy into electric current in the brake disc, fin, or rail, which is converted into heat. Still other braking methods even transform kinetic energy into different forms, for example by transferring the energy to a rotating flywheel.

Brakes are generally applied to rotating axles or wheels, but may also take other forms such as the surface of a moving fluid (flaps deployed into water or air). Some vehicles use a combination of braking mechanisms, such as drag racing cars with both wheel brakes and a parachute, or airplanes with both wheel brakes and drag flaps raised into the air during landing.

Since kinetic energy increases quadratically with velocity ($K = mv^2/2$), an object moving at 10 m/s has 100 times as much energy as one of the same mass moving at 1 m/s, and consequently the theoretical braking distance, when braking at the traction limit, is 100 times as long. In practice, fast vehicles usually have significant air drag, and energy lost to air drag rises quickly with speed. Almost all wheeled vehicles have a brake of some sort. Even baggage carts and shopping carts may have them for use on a moving ramp. Most fixed-wing aircraft are fitted with wheel brakes on the undercarriage. Some aircraft also feature air brakes designed to reduce their speed in flight.

Notable examples include gliders and some World War II-era aircraft, primarily some fighter aircraft and many dive bombers of the era. These allow the aircraft to maintain a safe speed in a steep descent. The Saab B 17 dive bomber and Vought F4U Corsair fighter used the deployed undercarriage as an air brake. Friction brakes on automobiles store braking heat in the drum brake or disc brake while braking then conduct it to the air gradually. When traveling downhill some vehicles can use their engines to brake.

When the brake pedal of a modern vehicle with hydraulic brakes is pushed, ultimately a piston pushes the brake pad against the brake disc which slows the wheel down. On the brake drum it is similar as the cylinder pushes the brake shoes against the drum which also slows the wheel down. Brakes may be broadly described as using friction, pumping, or electromagnetic. One brake may use several principles: for example, a pump may pass fluid through an orifice to create friction: Frictional brakes are most common and can be divided broadly into "shoe" or "pad" brakes, using an explicit wear surface, and hydrodynamic brakes, such as parachutes, which use friction in a working fluid and do not explicitly wear. Typically the term "friction brake" is used to mean pad/shoe brakes and excludes hydrodynamic brakes, even though hydrodynamic brakes use friction.

Friction (pad/shoe) brakes are often rotating devices with a stationary pad and a rotating wear surface. Common configurations include shoes that contract to rub on the outside of a rotating drum, such as a band brake; a rotating drum with shoes that expand to rub the inside of a drum, commonly called a "drum brake", although other drum configurations are possible; and pads that pinch a rotating disc, commonly called a "disc brake".

Other brake configurations are used, but less often. For example, PCC trolley brakes include a flat shoe which is clamped to the rail with an electromagnet; the Murphy brake pinches a rotating drum, and the Ausco Lambert disc brake uses a hollow disc (two parallel discs with a structural bridge) with shoes that sit between the disc surfaces and expand laterally. Pumping brakes are often used where a pump is already part of the machinery. For example, an internal-combustion piston motor can have the fuel supply stopped, and then internal pumping losses of the engine create some braking. Some engines use a valve override called a Jake brake to greatly increase pumping losses. Pumping brakes can dump energy as heat, or can be regenerative brakes that recharge a pressure reservoir called a hydraulic accumulator.

Electromagnetic brakes are likewise often used where an electric motor is already part of the machinery. For example, many hybrid gasoline/electric vehicles use the electric motor as a generator to charge electric batteries and also as a regenerative brake. Some diesel/electric railroad locomotives use the electric motors to generate electricity which is then sent to a resistor bank and dumped as heat.

Types of Braking system in Automobile;

- By applications –
 1. Foot Brake,
 2. Hand brake.

- By Method of power –
 1. Mechanical brake,
 2. Hydraulic brake.
 3. Vacuum brake,
 4. Electrical brake and
 5. Air brake.
- By method of operations –
 1. Manual brake,
 2. Servo brake.
 3. Power operation.
- By construction –
 1. Drum type brake,
 2. Disc type brake.

4.7. Anti-lock braking system (ABS)

Anti-lock braking system (ABS) is an automobile safety system that allows the wheels on a motor vehicle to maintain tractive contact with the road surface according to driver inputs while braking, preventing the wheels from locking up (ceasing rotation) and avoiding uncontrolled skidding. It is an automated system that uses the principles of threshold braking and cadence braking which were practiced by skillful drivers with previous generation braking systems. It does this at a much faster rate and with better control than a driver could manage.

ABS generally offers improved vehicle control and decreases stopping distances on dry and slippery surfaces for many drivers; however, on loose surfaces like gravel or snow-covered pavement, ABS can significantly increase braking distance, although still improving vehicle control.

Since initial widespread use in production cars, anti-lock braking systems have evolved considerably. Recent versions not only prevent wheel lock under braking, but also electronically control the front-to-rear brake bias. This function, depending on its specific capabilities and implementation, is known as electronic brake force distribution (EBD), traction control system, emergency brake assist, or electronic stability control (ESC).

Operation

The anti-lock brake controller is also known as the CAB (Controller Anti-lock Brake).

Typically ABS includes a central electronic control unit (ECU), four wheel speed sensors, and at least two hydraulic valves within the brake hydraulics. The ECU constantly monitors the rotational speed of each wheel; if it detects a wheel rotating significantly slower than the others, a condition indicative of impending wheel lock, it actuates the valves to reduce hydraulic pressure to the brake at the affected wheel, thus reducing the braking force on that wheel; the wheel then turns faster.

Conversely, if the ECU detects a wheel turning significantly faster than the others, brake hydraulic pressure to the wheel is increased so the braking force is reapplied, slowing down the wheel. This process is repeated continuously and can be detected by the driver via brake pedal pulsation. Some anti-lock systems can apply or release braking pressure 15 times per second.^[17] Because of this, the wheels of cars equipped with ABS are practically impossible to lock even during panic braking in extreme conditions.

The ECU is programmed to disregard differences in wheel rotative speed below a critical threshold, because when the car is turning, the two wheels towards the center of the curve turn slower than the outer two. For this same reason, a differential is used in virtually all roadgoing vehicles. If a fault develops in any part of the ABS, a warning light will usually be illuminated on the vehicle instrument panel, and the ABS will be disabled until the fault is rectified.

Modern ABS applies individual brake pressure to all four wheels through a control system of hub-mounted sensors and a dedicated micro-controller. ABS is offered or comes standard on most road vehicles produced today and is the foundation for electronic stability control systems, which are rapidly increasing in popularity due to the vast reduction in price of vehicle electronics over the years.

Modern electronic stability control systems are an evolution of the ABS concept. Here, a minimum of two additional sensors are added to help the system work: these are a steering wheel angle sensor, and a gyroscopic sensor. The theory of operation is simple: when the gyroscopic sensor detects that the direction taken by the car does not coincide with what the steering wheel sensor reports, the ESC software will brake the necessary individual wheel(s) (up to three with the most sophisticated systems), so that the vehicle goes the way the driver intends. The steering wheel sensor also helps in the operation of Cornering Brake Control (CBC), since this will tell the ABS that wheels on the inside of the curve should brake more than wheels on the outside, and by how much.

ABS equipment may also be used to implement a traction control system (TCS) on acceleration of the vehicle. If, when accelerating, the tire loses traction, the ABS controller can detect the situation and take suitable action so that traction is regained. More sophisticated versions of this can also control throttle levels and brakes simultaneously.

Components of ABS

There are four main components of ABS:

- Speed sensors,
- Valves,
- Pump, and
- Controller.

Speed sensors

A speed sensor is used to determine the acceleration or deceleration of the wheel. These sensors use a magnet and a coil of wire to generate a signal. The rotation of the wheel or differential induces a magnetic field around the sensor. The fluctuations of this magnetic field generate a voltage in the sensor. Since the voltage induced in the sensor is a result of the rotating wheel, this sensor can become inaccurate at slow speeds. The slower rotation of the wheel can cause inaccurate fluctuations in the magnetic field and thus cause inaccurate readings to the controller.

Valves

There is a valve in the brake line of each brake controlled by the ABS. On some systems, the valve has three positions:

In position one, the valve is open; pressure from the master cylinder is passed right through to the brake.

In position two, the valve blocks the line, isolating that brake from the master cylinder. This prevents the pressure from rising further should the driver push the brake pedal harder.

In position three, the valve releases some of the pressure from the brake.

The majority of problems with the valve system occur due to clogged valves. When a valve is clogged it is unable to open, close, or change position. An inoperable valve will prevent the system from modulating the valves and controlling pressure supplied to the brakes.

Pump

The pump in the ABS is used to restore the pressure to the hydraulic brakes after the valves

STUCOR APP

have released it. A signal from the controller will release the valve at the detection of wheel slip. After a valve release the pressure supplied from the user, the pump is used to restore a desired amount of pressure to the braking system. The controller will modulate the pumps status in order to provide the desired amount of pressure and reduce slipping.

Controller

The controller is an ECU type unit in the car which receives information from each individual wheel speed sensor, in turn if a wheel loses traction the signal is sent to the controller, the controller will then limit the brake force (EBD) and activate the ABS modulator which actuates the braking valves on and off.

Use

There are many different variations and control algorithms for use in ABS. One of the simpler systems works as follows,

The controller monitors the speed sensors at all times. It is looking for decelerations in the wheel that are out of the ordinary. Right before wheel locks up, it will experience a rapid deceleration.

If left unchecked, the wheel would stop much more quickly than any car could. It might take a car five seconds to stop from 60 mph (96.6 km/h) under ideal conditions, but a wheel that locks up could stop spinning in less than a second.

The ABS controller knows that such a rapid deceleration is impossible, so it reduces the pressure to that brake until it sees an acceleration, then it increases the pressure until it sees the deceleration again. It can do this very quickly, before the tire can actually significantly change speed. The result is that the tire slows down at the same rate as the car, with the brakes keeping the tires very near the point at which they will start to lock up. This gives the system maximum braking power.

This replaces the need to manually pump the brakes while driving on a slippery or a low traction surface, allowing steering even in the most emergency braking conditions.

When the ABS is in operation the driver will feel a pulsing in the brake pedal; this comes from the rapid opening and closing of the valves. This pulsing also tells the driver that the ABS has been triggered. Some ABS systems can cycle up to 16 times per second.

4.8. Hydraulic braking system

The disc brake or disk brake is a device for slowing or stopping the rotation of a wheel while it is in motion. A brake disc (or rotor in U.S. English) is usually made of cast iron, but may in some cases be made of composites such as reinforced carbon-carbon or ceramic-matrix composites.

This is connected to the wheel and/or the axle. To stop the wheel, friction material in the form of brake pads (mounted on a device called a brake caliper) is forced mechanically, hydraulically, pneumatically or electromagnetically against both sides of the disc. Friction causes

the disc and attached wheel to slow or stop. Brakes (both disc and drum) convert motion to heat, but if the brakes get too hot, they will become less effective because they cannot dissipate enough heat. This condition of failure is known as brake fade.

Construction of Braking system;

The most common arrangement of hydraulic brakes for passenger vehicles, motorcycles, scooters, and mopeds, consists of the following:

- Brake pedal or lever
- A pushrod (also called an actuating rod)
- A master cylinder assembly containing a piston assembly
- Reinforced hydraulic lines

Brake caliper assembly usually consisting of one or two hollow aluminum or chrome-plated steel pistons (called caliper pistons), a set of thermally conductive brake pads and a rotor (also called a brake disc) or drum attached to an axle. The system is usually filled with a glycol-ether based brake fluid (other fluids may also be used).

At one time, passenger vehicles commonly employed drum brakes on all four wheels. Later, disc brakes were used for the front and drum brakes for the rear. However disc brakes have shown better heat dissipation and greater resistance to 'fading' and are therefore generally safer than drum brakes. So four-wheel disc brakes have become increasingly popular, replacing drums on all but the most basic vehicles. Many two-wheel vehicle designs, however, continue to employ a drum brake for the rear wheel. The following description uses the terminology for and configuration of a simple

In a hydraulic brake system, when the brake pedal is pressed, a pushrod exerts force on the piston(s) in the master cylinder, causing fluid from the brake fluid reservoir to flow into a pressure chamber through a compensating port. This results in an increase in the pressure of the entire hydraulic system, forcing fluid through the hydraulic lines toward one or more calipers where it acts upon one or two caliper pistons sealed by one or more seated O-rings (which prevent leakage of the fluid).

The brake caliper pistons then apply force to the brake pads, pushing them against the spinning rotor, and the friction between the pads and the rotor causes a braking torque to be generated, slowing the vehicle. Heat generated by this friction is either dissipated through vents and channels in the rotor or is conducted through the pads, which are made of specialized heat-tolerant materials such as kevlar or sintered glass.

Subsequent release of the brake pedal/lever allows the spring(s) in my master cylinder assembly to return the master piston(s) back into position. This action first relieves the hydraulic pressure on the caliper, then applies suction to the brake piston in the caliper assembly, moving it back into its housing and allowing the brake pads to release the rotor.

The hydraulic braking system is designed as a closed system: unless there is a leak in the

system, none of the brake fluid enters or leaves it, nor does the fluid get consumed through use.

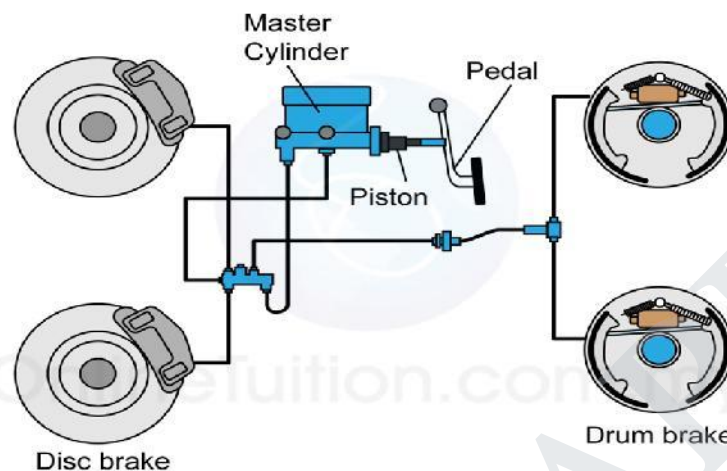

4.9. Pneumatic braking system

An air brake or, more formally, a compressed air brake system, is a type of friction brake for vehicles in which compressed air pressing on a piston is used to apply the pressure to the brake pad needed to stop the vehicle.

Air brakes are used in large heavy vehicles, particularly those having multiple trailers which must be linked into the brake system, such as trucks, buses, trailers, and semi-trailers in addition to their use in railroad trains.

George Westinghouse first developed air brakes for use in railway service. He patented a safer air brake on March 5, 1872. Westinghouse made numerous alterations to improve his air pressured brake invention, which led to various forms of the automatic brake. In the early 20th century, after its advantages were proven in railway use, it was adopted by manufacturers of trucks and heavy road vehicles.

Construction of Braking system;

Air brake systems are typically used on heavy trucks and buses. The system consists of service brakes, parking brakes, a control pedal, and an air storage tank. For the parking brake, there is a disc or drum brake arrangement which is designed to be held in the 'applied' position by spring pressure.

Air pressure must be produced to release these "spring brake" parking brakes. For the service brakes (the ones used while driving for slowing or stopping) to be applied, the brake pedal is pushed, routing the air under pressure (approx 100–120 psi or 690–830 kPa) to the brake chamber, causing the brake to be engaged. Most types of truck air brakes are drum brakes, though there is an

increasing trend towards the use of disc brakes in this application. The air compressor draws filtered air from the atmosphere and forces it into high-pressure reservoirs at around 120 psi (830 kPa).

Most heavy vehicles have a gauge within the driver's view, indicating the availability of air pressure for safe vehicle operation, often including warning tones or lights. Setting of the parking/emergency brake releases the pressurized air in the lines between the compressed air storage tank and the brakes, thus allowing the spring actuated parking brake to engage. A sudden loss of air pressure would result in full spring brake pressure immediately.

A compressed air brake system is divided into a supply system and a control system. The supply system compresses, stores and supplies high-pressure air to the control system as well as to additional air operated auxiliary truck systems (gearbox shift control, clutch pedal air assistance servo, etc.).

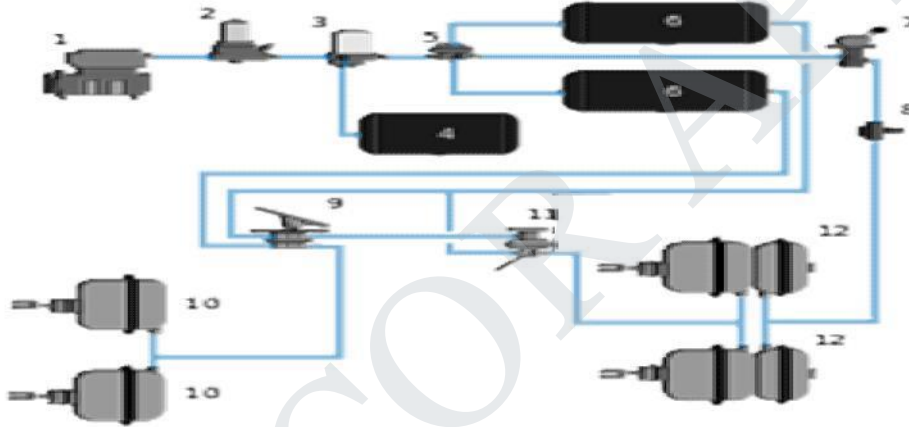

Highly simplified air brake diagram on a commercial road vehicle (does not show all air reservoirs and all applicable air valves). The air compressor is driven by the engine either by crankshaft pulley via a belt or directly from the engine timing gears. It is lubricated and cooled by the engine lubrication and cooling systems.

Compressed air is first routed through a cooling coil and into an air dryer which removes moisture and oil impurities and also may include a pressure regulator, safety valve and smaller purge reservoir. As an alternative to the air dryer, the supply system can be equipped with an anti-freeze device and oil separator. The compressed air is then stored in a reservoir (also called a wet tank) from which it is then distributed via a four way protection valve into the front and rear brake circuit air reservoir, a parking brake reservoir and an auxiliary air supply distribution point. The system also includes various check, pressure limiting, drain and safety valves. Air brake systems may include a wig wag device which deploys to warn the driver if the system air pressure drops too low.

Control system

The control system is further divided into two service brake circuits: the parking brake circuit and the trailer brake circuit. This dual brake circuit is further split into front and rear wheel circuits which receive compressed air from their individual reservoirs for added safety in case of an

air leak. The service brakes are applied by means of a brake pedal air valve which regulates both circuits.

The parking brake is the air operated spring brake type where its applied by spring force in the spring brake cylinder and released by compressed air via hand control valve. The trailer brake consists of a direct two line system: the supply line (marked red) and the separate control or service line (marked blue). The supply line receives air from the prime mover park brake air tank via a park brake relay valve and the control line is regulated via the trailer brake relay valve. The operating signals for the relay are provided by the prime mover brake pedal air valve, trailer service brake hand control (subject to a country's relevant heavy vehicle legislation) and the prime mover park brake hand control.

Advantages of Air Brakes;

Air brakes are used as an alternative to hydraulic brakes which are used on lighter vehicles such as automobiles. Hydraulic brakes use a liquid (hydraulic fluid) to transfer pressure from the brake pedal to the brake shoe to stop the vehicle. Air brakes have several advantages for large multitrailer vehicles:

- The supply of air is unlimited, so the brake system can never run out of its operating fluid, as hydraulic brakes can. Minor leaks do not result in brake failures.
- Air line couplings are easier to attach and detach than hydraulic lines; there is no danger of letting air into hydraulic fluid. So air brake circuits of trailers can be attached and removed easily by operators with little training.
- Air not only serves as a fluid for transmission of force, but also stores potential energy. So it can serve to control the force applied. Air brake systems include an air tank that stores sufficient energy to stop the vehicle if the compressor fails.
- Air brakes are effective even with considerable leakage, so an air brake system can be designed with sufficient "fail-safe" capacity to stop the vehicle safely even when leaking.

4.10. Loss of Traction:

One undesirable side effect of a differential is that it can reduce overall torque - the rotational force which propels the vehicle. The amount of torque required to propel the vehicle at any given moment depends on the load at that instant - how heavy the vehicle is, how much drag and friction there is, the gradient of the road, the vehicle's momentum and so on. For the purpose of this article, we will refer to this amount of torque as the "threshold torque".

The torque on each wheel is a result of the engine and transmission applying a twisting force against the resistance of the traction at that wheel. Unless the load is exceptionally high, the engine and transmission can usually supply as much torque as necessary, so the limiting factor is usually the traction under each wheel. It is therefore convenient to define traction as the amount of torque that can be generated between the tire and the ground before the wheel starts to slip. If the total traction

under all the driven wheels exceeds the threshold torque, the vehicle will be driven forward; if not, then one or more wheels will simply spin.

To illustrate how a differential can limit overall torque, imagine a simple rear-wheel-drive vehicle, with one rear wheel on asphalt with good grip, and the other on a patch of slippery ice. With the load, gradient, etc., the vehicle requires, say, 2000 N-m of torque to move forward (i.e. the threshold torque). Let us further assume that the non-spinning traction on the ice equates to 400 N-m, and the asphalt to 3000 N-m.

If the two wheels were driven without a differential, each wheel would push against the ground as hard as possible. The wheel on ice would quickly reach the limit of traction (400 N-m), but would be unable to spin because the other wheel has good traction. The traction of the asphalt plus the small extra traction from the ice exceeds the threshold requirement, so the vehicle will be propelled forward.

With a differential, however, as soon as the "ice wheel" reaches 400 N-m, it will start to spin, and then develop less traction ~300 N-m. The planetary gears inside the differential carrier will start to rotate because the "asphalt wheel" encounters greater resistance.

Instead of driving the asphalt wheel with more force, the differential will allow the ice wheel to spin faster, and the asphalt wheel to remain stationary, compensating for the stopped wheel by extra speed of the spinning ice wheel. The torque on both wheels will be the same - limited to the lesser traction of 300 N-m each. Since 600 N-m is less than the required threshold torque of 2000 N-m, the vehicle will not be able to move.

An observer simply sees one stationary wheel and one spinning wheel. It will not be obvious that both wheels are generating the same torque (i.e. both wheels are in fact pushing equally, despite the difference in rotational speed). This has led to a widely held misconception that a vehicle with a differential is really only "one-wheel-drive". In fact, a normal differential always provides equal torque to both driven wheels (unless it is a locking, torque-biasing, or limited slip type).

Traction control system (TCS),

A **traction control system (TCS)**, in German known as **Antriebsschlupfregelung (ASR)**, is typically (but not necessarily) a secondary function of the anti-lock braking system (ABS) on production motor vehicles, designed to prevent loss of traction of driven road wheels. TCS is activated when throttle input and engine torque are mismatched to road surface conditions.

Intervention consists of one or more of the following:

- Brake force applied to one or more wheels
- Reduction or suppression of spark sequence to one or more cylinders
- Reduction of fuel supply to one or more cylinders
- Closing the throttle, if the vehicle is fitted with drive by wire throttle
- In turbocharged vehicles, a boost control solenoid is actuated to reduce boost and therefore engine power.

Typically, traction control systems share the electro hydraulic brake actuator (which does not use the conventional master cylinder and servo) and wheel speed sensors with ABS.

UNIT-V

ALTERNATIVE ENERGY SOURCES

PROPERTIES OF ALTERNATE FUELS

Although a large number of fuel properties influence engine performance, subsets of these properties are reviewed to highlight differences among the petroleum-based and alternative fuels in this section.

1. Energy density:

Conventional gasoline (petrol), oxygenated and reformulated gasoline and diesel which are liquids have higher energy densities. Ethanol and methanol also are liquids at atmospheric pressure and ambient temperature. So, they are stored and handled similar to gasoline though they have less energy density. Methanol has about half the energy content of gasoline on a volume basis while ethanol has about two-thirds of energy density.

LPG while a gas at normal temperature and pressure is stored in a liquid form under the pressure in the range from 100 *psi* to 300 *psi*. While butane has higher energy density per m³ than propane, both propane and butane have lower energy content per m³ than diesel or petrol.

Natural gas is stored in the vehicle fuel tanks under pressure as a compressed gas. Even under fairly high pressure, both mass density and energy density of a gas are considerably less than liquid. The energy density disadvantage of CNG is partially resolved with LNG because

LNG is simply natural gas which has been liquefied. LNG tanks might be pressurized around 30 *psi* and hold the liquid at a temperature of -260° *F*. Sometimes, two to four times more LNG than CNG which can be stored on board.

2. Volatility:

Volatility indicates a fuel's ability to vapourize under different temperature and pressure. It is the property that most affects start up the engine performance and it is of particular interest for SI engines while high volatility is desirable in cold weather. It can cause loss of power or vapour lock in warmer weather. High volatility can also lead to increased evaporative emissions. Thus, volatility is controlled for both engine performance and emissions.

3. Octane number:

Octane number is a measure a fuel's tendency to knock in a SI engine. Knocking occurs when the gasoline-air vapour mixture prematurely self-ignites as the mixture is compressed during the upward movement of the piston. The self-ignition occurs before the cylinder reaches the top of its stroke thereby causing the cylinder to push against the crank shaft. It creates a knock which not only works against the motive power of the engine but also puts a strain on mechanical parts. Generally, the higher is the octane number, the higher will be the compression ratio which can be tolerated without knocking. Engines with higher compression ratio have more power and higher efficiencies.

4. *Cetane number:*

The combustion and ignition characteristics of CI engine fuels are expressed in the form of cetane number. Fuels with high cetane numbers have low auto-ignition temperature and short ignition delay times. Since a high octane number means a low cetane number, none of alternative fuels have cetane values high enough to be used alone in unmodified CI engines, However, engine designers are developing modified CI engines for heavy-duty use which include an ignition device and it changes to accommodate the lack of cetane value in these fuels.

5. *Heat of vapourization:*

Heat of vapourization affects both engine power and efficiency. It is the amount of heat absorbed by fuel as it evaporates from a liquid state which occurs when the fuel is mixed with air prior to combustion. High heat of vaporization leads to improved cooling ability. The higher cooling during the intake stroke of a SI engine results a denser air/fuel mixture. A denser mixture has two effects. They are (1) allowing for greater power and (2) permitting a greater compression ratio which improves both power and efficiency. However, although a high heat of vapourization improves power and efficiency, it also adds to cold start problems when there is less heat in the air or in the engine to vapourize the fuel prior to spark ignition.

The alcohol fuels have higher heat of vapourization than gasoline or diesel. For methanol, a typical power increase about 10 % from increased air/fuel mixture density has been observed in unmodified automotive engines using methanol instead of gasoline.

6. *Flame speed:*

The speed at which a flame front propagates through a fuel/air mixture can affect engine performance and emissions. High flame speed allows the complete combustion and potentially lean fuel mixtures. While liquid fuels have similar flame speed. methanol is thought to have a higher flame speed than gasoline. However, natural gas has a slow flame speed than other fuels which impairs the spark-engine efficiency unless the spark timing is advanced to compensate. Hydrogen has the highest flame speed of alternative fuels which reduces burning time and heat losses from the cylinder. It improves the thermal efficiency over fuels with lower flame speed.

7. *Flame temperature and luminosity:*

The alcohol fuels distinguish themselves in this area. For alcohol fuels, the flame temperature is lower than gasoline and luminosity is so low that less thermal energy is lost through conduction or radiation. Low flame temperature also helps to reduce the formation of nitrogen oxide. However, low luminosity is a safety issue because the flame is essentially invisible. Hydrogen also is virtually invisible when burning.

8. Auto-ignition temperature:

Auto-ignition temperature is a temperature at which the fuel will self-ignite. Self-ignition is a concern in the environment where the fuel might escape and come into contact with hot engine parts. As a safety feature, high auto-ignition temperatures are desirable. Hydrogen has the highest auto-ignition temperature about $1,065^{\circ}\text{F}$ followed by natural gas, propane, methanol and ethanol. Gasoline and diesel have the lowest auto-ignition temperatures at 495°F and 600°F respectively. Based on this measure, all alternative fuels have an advantage over gasoline. While both natural gas and hydrogen have high auto-ignition temperature, they require different amount of energy to ignite mixtures of fuel and air. Since the natural gas fuel/air mixtures are difficult to ignite, natural-gas-fuelled engines must use high-energy spark plugs. Hydrogen fuel/air mixtures need less energy to ignite. For stoichiometric fuel/air ratio, hydrogen requires one-tenth of the energy to ignite than hydrocarbon fuels.

9. Flashpoint:

The flashpoint is the lowest temperature at which combustible mixtures of fuel vapour and air form above the fuel. In the presence of a spark, such mixtures will ignite. A high flashpoint is desirable from a safety standpoint but none of alternative fuels has an advantage

in this area. All fuels but diesel has flashpoint at ambient or lower than the ambient temperature. However, the alcohol fuels have higher flashpoint than gasoline.

10. Flammability:

Flammability limits the range of fuel/air mixtures that ignite. From a safety perspective, a wide range is less desirable than a narrow range. Among hydrocarbon fuels, methanol has the widest flammability limits (7.3% to 36%) followed by ethanol. In partially filled or empty storage tanks, alcohol fuels are to produce more combustible mixture above fuel than other alternative hydrocarbon fuels.

USE OF NATURAL GAS IN AUTOMOBILES

Natural gas is a fossil fuel such as petroleum and coal. Natural gas is called *fossil fuel* because most scientists believe that it was formed from remains of ancient sea plants and animals. When the plants and tiny sea animals died, they sank at the bottom of oceans where they were buried by sediment and sand is turned into sedimentary rock. The layers of plants and animal matter and

sedimentary rock continued to build until the pressure and heat from the earth turned remains into petroleum and natural gas.

Various Forms of Natural Gas

1. Methane:

Natural gas is primarily methane (CH₄). It makes natural gas as a friendly fuel for the environment. Methane as a hydrocarbon is considered non-reactive. It means, hydrocarbon emissions of natural gas do not react with sunlight to create smog. When natural gas is used as an engine fuel, the Society of Automotive Engineers (SAE) has established a standard minimum methane content of 95%.

Advantages of methane as fuels in automobiles:

- (i) It has very low emissions of ozone-forming hydrocarbons, toxics and carbon monoxide.
- (ii) It can be made from a variety of feed stocks including renewable.
- (iii) It is excellent fuel especially for fleet vehicles.

Disadvantages of methane as fuels in automobiles:

- (i) Vehicle cost is higher.
- (ii) Vehicle range is lower.
- (iii) It has less convenient refuelling.

2. Ethanol:

Ethanol called "grain alcohol" is the primary automotive fuel in Brazil and ethanol/gasoline blend is known as "gasohol" which has been used in the United States for many years. Pure ethanol fuel offers the excellent performance and low hydrocarbon and toxic emissions. It can be produced domestically from corn or other crops as well as from cellulose materials such as wood or paper wastes which potentially minimizes the accumulation of greenhouse gases since these "renewable" feedstock draw carbon dioxide in atmosphere as they grow. With current technology and price structures, ethanol is more expensive than gasoline. New technologies offer the hope of significantly reduced cost.

Advantages of ethanol as fuels in automobiles:

- (i) It is excellent automotive fuel.
- (ii) It has very low emissions of ozone-forming hydrocarbons and toxics.
- (iii) It can be made from renewable sources.
- (iv) It can be domestically produced.

Disadvantages of ethanol as fuels in automobiles:

- (i) Fuel cost is high.
- (ii) Vehicle range is somewhat lower.

3. Methanol:

Methanol called "*wood alcohol*" is a high-performance liquid fuel which emits low level toxic and ozone-forming compounds. It can be produced at price comparable to gasoline from natural gas and it can also be produced from coal and wood. All major auto manufacturers have produced cars which run on "M85" which has a blend of 85% methanol and 15% gasoline. Cars that burn pure methanol (MI00) offer much greater air quality and efficiency.

Advantages of methanol as fuels in automobiles:

- (i) It is excellent automotive fuel.
- (iii) It has very low emissions of ozone-forming hydrocarbons and toxics.
- (iii) It can be made from a variety of feedstock including renewable.

Disadvantage of methanol as fuels in automobiles:

Vehicle range is less.

4. Propane:

Propane or liquefied petroleum gas (LPG) is a by-product of petroleum refining and natural gas production. It burns completely than gasoline but it is limited in supply. Propane-fuelled vehicles are already common in many parts of the world.

Advantages of propane as fuels in automobiles:

- (i) It is cheaper than gasoline today.
- (ii) It is widely available clean fuel today.
- (iii) Emissions are less in ozone forming hydrocarbons and toxics.
- (iv) It is excellent fuel especially for fleet vehicles.

Natural Gas Production:

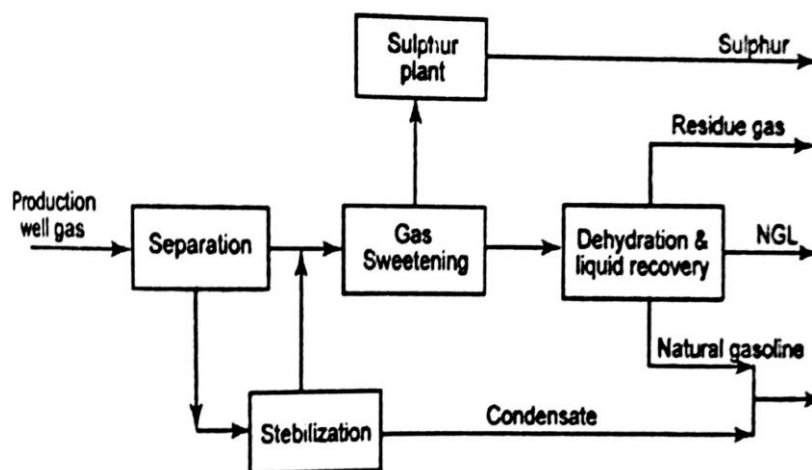

USE OF LPG IN AUTOMOBILES:

Most people pronounce Liquefied Petroleum Gas (LPG) as "*propane*" because LPG is mostly made up of propane. Actually, LPG is made of a mixture of propane and other similar types of hydrocarbon gases. Different batches of LPG have slightly different amount of various kind of hydrocarbon molecules. These hydrocarbons are gases at room temperature but turn to liquid when they are compressed. LPG is stored in special tanks which keep it under pressure. Therefore, it stays as liquid. The pressure of these tanks is usually about *14bar*.

LPG is the name given to the mixture of petroleum gases released during the extraction of crude oil and natural gas during refining the crude oil. It consists of a mixture of hydrocarbons including major components of propane and butane and minor components are normal-butane, iso-butane, pentane, ethane, propene and butene together with small quantities of additives including sulphur to give it an odour for safety reasons. Propane (C_3H_8) and butane (C_4H_{10}) are the main components but different mixing ratios are used in different countries which reflect the local market prices, production facilities and climatic conditions. LPG is a gas which can be stored in a liquid state under low pressure due to its low vapour tension.

Advantages of LPG:

1. It has very low sulphur level giving a rise to insignificant sulphate emissions.
2. It has low cold start emissions due to its gaseous state at ambient pressure and temperature.
3. It has relatively high octane number with propane having the best antiknock properties relative to other components.

4. It has lower peak pressure during combustion which generally reduces noise and improves durability. Noise levels can be less than 50% of equivalent diesel engines.

USE OF BIO-DIESEL IN AUTOMOBILES:

Biodiesel is a fuel derived from vegetable oil or animal fats. It can be used as an additive to or entirely replace conventional petroleum diesel fuel. The majority of biodiesel is made from soybean or canola oils but it is also made from waste stream sources such as used cooking oils or animal fats.

In most cases, biodiesel is mixed with conventional diesel because of high cost of biodiesel; engine compatibility issues and cold weather operating concerns are considered. Common blends are B20 or 20% biodiesel and B2 or 2% biodiesel. The environmental benefits of using biodiesel scales with the percentage of biodiesel contains in the blend.

- **B100:** 100% biodiesel offers the most overall environmental benefits. Use of B100 may require engine or fuel system component modification and it can cause operating problems especially in cold weather.
- **B20:** 20% biodiesel offers about one fifth of the environmental benefits of B100 but it can be more broadly applied to existing engines with little or no modification.
- **B2:** 2% biodiesel offers little environmental or petroleum dependence benefit and it could be potentially used an environmental marketing tool.

Biodiesel production

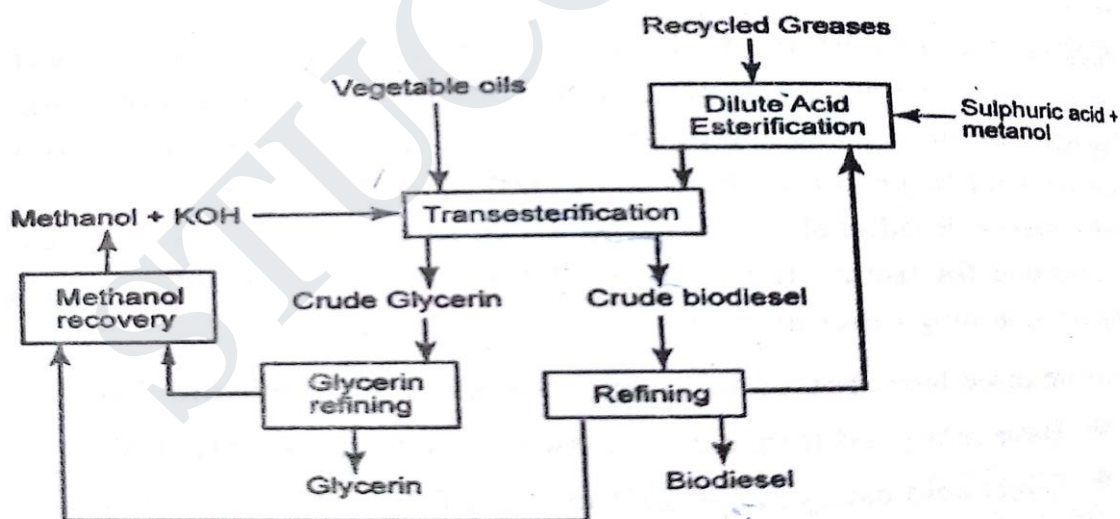

Biodiesel is produced from vegetable oils by converting the triglyceride oils to methyl (or ethyl) esters with a process known as *transesterification*. In transesterification process, alcohol reacts with the oil to

release three "ester chains" from the glycerin backbone of each triglyceride. The reaction requires heat and a strong base catalyst (e.g. sodium or potassium hydroxide which has already been mixed with the methanol) to achieve complete conversion of the vegetable oil into the separated esters and glycerin.

The methanol is charged in excess to assist in quick conversion and recovered for reuse. The glycerin can be further purified for sale to the pharmaceutical and cosmetic industries. The mono-alkyl esters become biodiesel with one-eighth the viscosity of the original vegetable oil. Each ester chain, usually 18 carbons in length for soy esters retains two oxygen atoms forming the "ester" and giving the product its unique combustion qualities as an oxygenated vegetable based fuel. Biodiesel is nearly 10% oxygen by weight. The general process of producing biodiesel is shown in Figure.

USE OF BIO-ETHANOL IN AUTOMOBILES

Ethanol fuel is *ethyl alcohol* (or simply *alcohol*) which is found as the similar type of alcohol in alcoholic beverages. It is most often used as a motor fuel mainly as a bio-fuel additive for gasoline. Bio-ethanol is one of form of renewable energy. It can be produced from agricultural feed-stocks. It can be made from very common crops such as sugar cane, potato, manioc and corn. Cellulosic ethanol offers more advantages because cellulose fibers, a major and universal component in plant cells walls can be used to produce ethanol. According to the International Energy Agency, cellulosic ethanol will allow ethanol fuels to play an important role in future.

Bio-Ethanol (Alcohol) Production

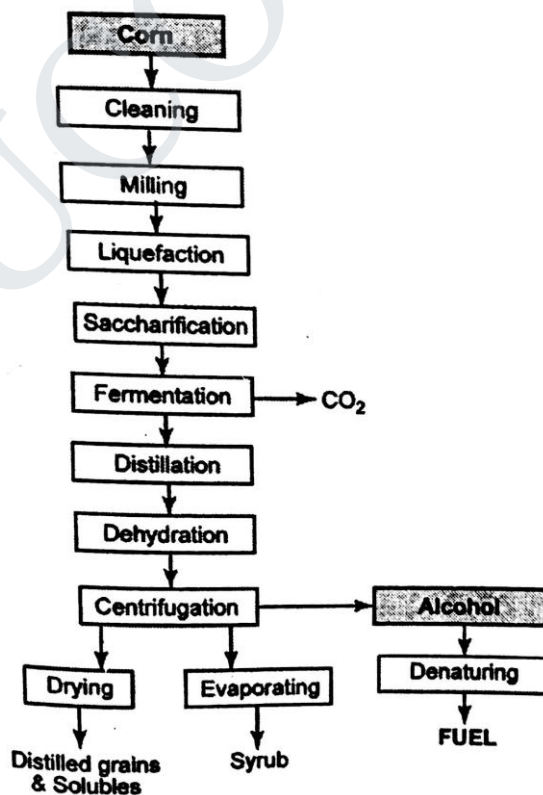

USE OF GASOHOL IN AUTOMOBILES

Gasohol is a mixture of 10% ethanol (ethyl alcohol) and 90% unleaded gasoline.

Although automobiles could be designed to operate on alcohol alone for the foreseeable future, the most economic use of ethanol is as an octane booster in gasoline. So, gasohol is a much cleaner fuel than gasoline itself. Gasohol can be used without modifying the carburettor or fuel injector, ignition timing or fuel lines of an automobile. This fuel has higher octane value and anti-knock properties than gasoline and burns slowly and completely results the reduced emissions of some pollutants but it also vapourizes more readily and potentially aggravating ozone pollution in warm weather.

Ethanol is an alternative energy source. It is an alcohol made by fermenting corn or other similar biomass material as explained earlier. There are three primary ways that ethanol can be used as a transportation fuel.

1. As a blend of 10 % ethanol with 90 % unleaded gasoline called "E-10' Unleaded";
- 2.As a component of reformulated gasoline, both directly and as ethyl tertiary butyl ether (ETBE)
3. As a primary fuel with 85 parts of ethanol blended with 15 parts of unleaded gasoline called "E-85."

USE OF HYDROGEN FUELS IN AUTOMOBILES:

Hydrogen is the lightest element which may someday replace heavier compounds as a source of energy for transportation and many other applications. Although low-cost technology to allow this odorless, colorless, diffuse gas to be collected, hydrogen's potential to be a clean energy source has some hope about a future "hydrogen economy" which would not rely on fossil fuels.

Production of Hydrogen

Hydrogen is the simplest and most abundant element in the universe which holds great promise as a fuel. Two methods are generally used to produce hydrogen gas such as ' electrolysis and synthesis gas production.

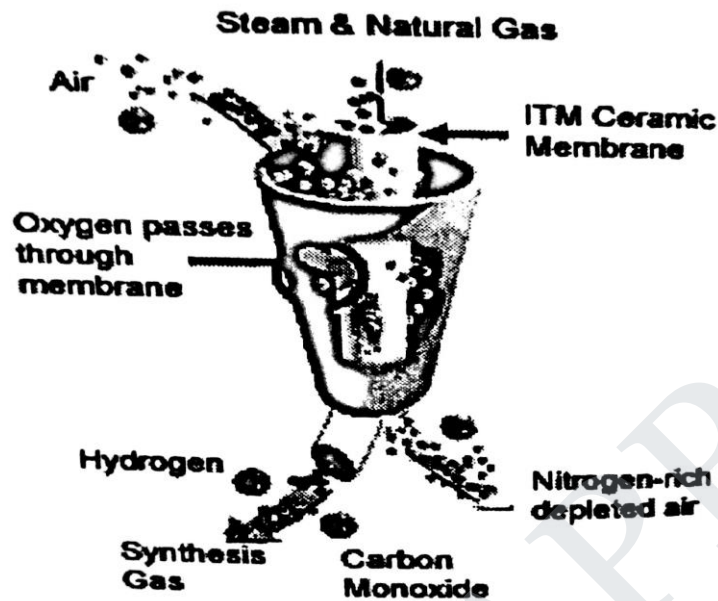

Engine Modification for Bio-Ethanol (Alcohol) and Gasohol

The addition of an ethanol E10 blend to petrol will increase the octane number of the petrol fuel by two points. Therefore, bio-ethanol is termed as an "octane enhancer". An ethanol 10 blend of fuel will normally have an oxygen content of 3.5%. The oxygen present

In ethanol affects the air to fuel ratio. The air / fuel ratio of ethanol is 12.7:1 which is slightly less than the 14.6: 1 air / Wei ratio used for conventional fuels.

1. Fuel filters:

It is necessary to change vehicle's fuel filter more often as ethanol blends can loosen solid deposits in fuel tanks and fuel lines.

2. Cold starting:

Ethanol blends have high latent heat of evaporation than pure petrol thereby having poor cold start ability in winter. Hence, some vehicles have small petrol tank fitted containing pure petrol for starting the vehicle in cold weather.

3. Mechanical modifications required/or bioethanol as a fuel in SI engine:

Generally, the modifications might be carried out in the following elements of engine irrespective of type of engines such as changes to cylinder walls, cylinder heads, valves and valve seats, pistons, piston rings, intake manifolds and carburetors, nickel plating of steel fuel lines, fuel tanks to prevent ethanol E20 corrosion and high fuel flow rate injectors to compensate oxygenate qualities of ethanol.

When gasoline containing more than 25% ethanol is used in SI engines, some modification must be made to the engine. Before mechanical modifications are undertaken on an engine, a choice must be made to the ease of reversibility of the engine change and the availability of alcohol fuel for all anticipated vehicle lies, cost of the engine modifications, and expertise required in making the engine modification.

(a) Reversible modifications:

These modifications can be done with the relative ease to permit operation on convention fuels. These modifications include as follows:

1. Changing the spark timing.
2. Changing the vacuum advance.
3. Modifying the carburetion for increased fuel flow.
4. Heating the air-fuel mixture to ensure the vapourization of the alcohol, and
5. Using various methods to enhance the cold starting ability of the engine.

(i) Spark timing:

The spark timing of an engine must be advanced to run on ethanol. It is done to provide ethanol with enough time to complete combustion since ethanol burns slower than gasoline.

(ii) Vacuum advance:

The vacuum advance affects the fuel economy of the engine operating on ethanol. So, the vacuum advance is set to give an additional 10° of advance over idle ignition time.

(iii) Carburettor modification:

Generally, engines require more volume of fuel when operated on ethanol as compared to operation on gasoline. The correct stoichiometric air-fuel mixture for ethanol is 9:1 while the correct mixture for gasoline is 14.7: 1. It is due to the difference in energy content per volume because ethanol has low energy content per volume than gasoline. The fuel-flow increase is achieved by modifying the carburetor. The general procedure for the fuel flow increase is to enlarge the carburettor fuel jet diameter 1.5times. It can be done by drilling out the original to replace the jet.

(iv) Preheating air-fuel mixture:

The air-ethanol fuel mixture requires 2.5 times more heat for vapourization the gasoline. Therefore, some additional heat may be desirable for the air fuel mixture before it enters the cylinder.

(v) Cold start modification:

One of main problems in using ethanol engine is low temperature. This problem arises due to the requirement of more heat for vapourization of ethanol than gasoline. The cold-start problem with ethanol can be overcome in several different ways. It can be overcome by the use of additives.

(b) Irreversible modifications:

Modifications are hard to remove. They also are usually more expensive, require more expertise and can be very hazardous when the engine fails. The possible modifications are:

1. Cam shaft change,
2. Increasing the engine compression ratio and
3. Using turbochargers or superchargers.

(i) Camshaft change:

The cam shaft is changed in such a way to provide more RPM torque, easier starting and better fuel economy.

(ii) Increasing in compression ratio:

The compression ratio is increased to increase the octane rating of ethanol to produce more power. The increased compression ratio is from 7: 2: 1 to 11:1.

(iii) Using turbochargers or superchargers:

The turbochargers and superchargers are used in order to increase the fuel admit pressure during suction stroke of the engine.

ELECTRIC VEHICLES

Battery-powered vehicles give off virtually no pollution and offer one of the best options for reducing motor vehicle emissions in polluted cities. The driving range of today's electric cars is limited by the amount of power and the battery can provide. Current batteries take hours to recharge and the cost of electric vehicles is high. Recent developments in electric vehicle technology show much promise for future.

Working of Electric Vehicles

Electric vehicles (EVs) do not burn gasoline in an engine. They use electricity stored on the car in batteries. Sometimes, 12 or 24 batteries or more are needed to power the car such as a remote-controlled and model electric car. EVs have an electric motor which turns wheels and a battery to run.

Electricity, the same energy that lights lamps and runs TV is stored in batteries on an EV. In an EV, batteries and other energy storage devices are used to store the electricity that powers the electric

motor in the vehicle. Figure shows the typical arrangement of batteries and electric motor in an electric car. The batteries can be lead acid batteries or Ni-cad (nickel-cadmium). EV batteries must be replenished by plugging in the vehicle to a power source.

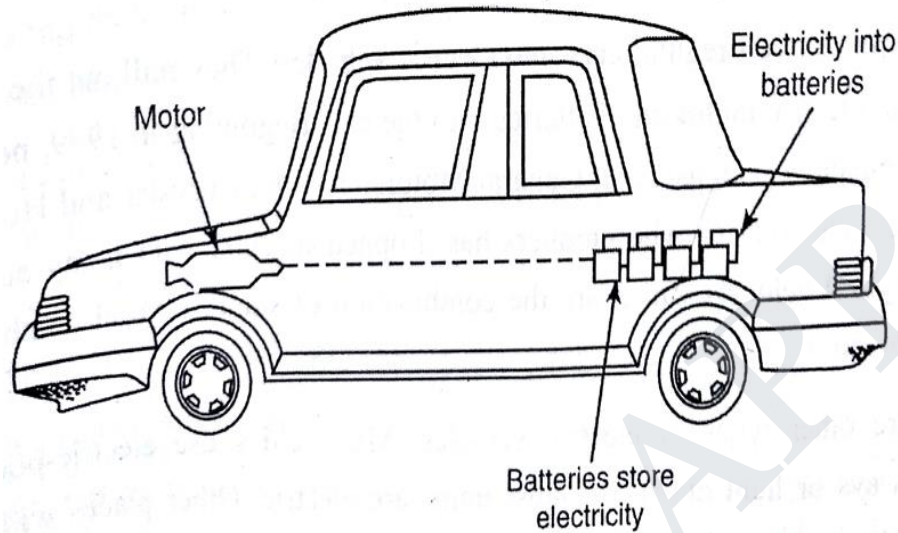

Benefits of Electric Vehicles

EVs are zero emission vehicles. It means, they produce no tailpipe or evaporative emissions that contribute to air pollution and global warming (although electricity production is not pollution-free).

The cost of electricity per kilowatt-hour usually compares favourably to gasoline but it varies depending on location. More than 95% of the electricity used to charge EVs originates from domestic resources. So, driving an EV reduces the nation's dependence on imported oil.

Limitations of Electric Vehicles

1. It has less initial torque.
2. It is more expensive.
3. Frequent recharging of battery is needed and also battery charging needs more time.

HYBRID VEHICLES

The word *hybrid* means, something is mixed together from two things. Usually, it refers to plants or animals that are bred from different dissimilar parents. Hybrid electric vehicles (HEVs) typically combine the internal combustion engine of a conventional vehicle with the battery and electric motor of an electric vehicle.

The combination offers low emissions, power, range and convenient fuelling of conventional (gasoline and diesel) vehicles and they never need to be plugged in. The inherent flexibility of HEVs makes them well suited for fleet and personal transportation.

Working Principle of Hybrid Vehicles

Hybrid electric vehicles (HEVs) are powered by two energy sources such as an energy conversion unit (combustion engine or fuel cell) and an energy storage device (batteries or ultra-capacitors) as shown in Figure. The energy conversion unit may be powered by gasoline, methanol, compressed natural gas, hydrogen or other alternative fuels. Hybrid electric vehicles have the potential to be two to three times more fuel-efficient than conventional vehicles.

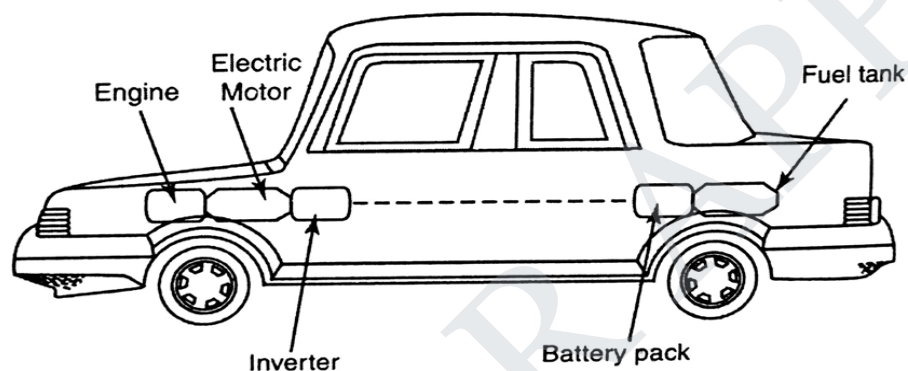

HEVs can have a parallel design, a series design or a combination of these two. In a parallel design, the energy conversion unit and electric propulsion system are connected directly to vehicle's wheels. The primary engine is used for highway driving. The electric motor provides the added power during hill climbing, acceleration and other periods of high demand. In a series design, the primary engine is connected to a generator which produces the electricity. The electricity charges the batteries which drive an electric motor which powers wheels. HEVs can also be built to use the series configuration at low speed and the parallel configuration for highway driving and acceleration.

In contrast to electric vehicles, batteries in HEVs do not need to be plugged into recharge. Instead, they are recharged using a regenerative braking or by using an on-board generator.

Parallel HEV Design

A hybrid electric vehicle (HEV) with a parallel configuration has a direct mechanical connection between hybrid power unit and wheels as in a conventional vehicle but it also has an electric motor which drives wheels as shown in Figure. For example, a parallel vehicle could use power produced by an internal combustion engine for highway driving while using both engine and electric motor power for accelerating.

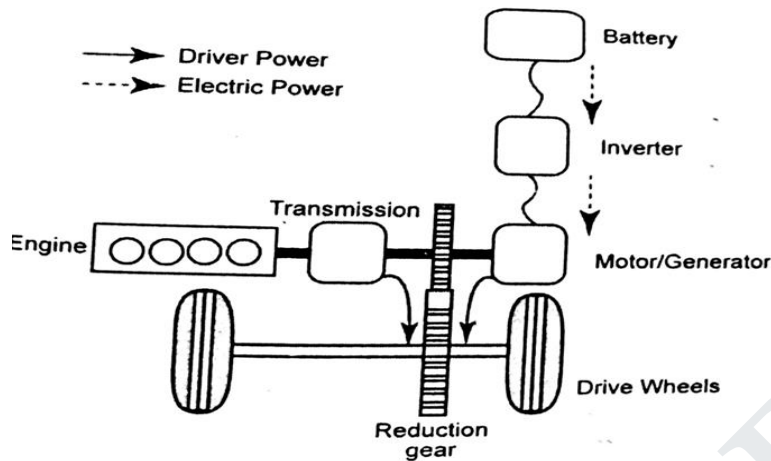

Some benefits of a parallel configuration are as follows:

1. A smaller engine provides more efficient operation and therefore, better fuel economy is without sacrificing acceleration power. The vehicle has more power because both engine and motor supply power simultaneously.
2. Most parallel vehicles do not need a separate generator because the motor regenerates batteries.

Series HEV Design

A hybrid electric vehicle (HEV) with a series configuration uses the heat engine or fuel cell with a generator to produce electricity for the battery pack and electric motor as shown in Figure. Series HEVs have no mechanical connection between hybrid power unit and wheels. All motive power is transferred from chemical energy to mechanical energy and from mechanical energy to electrical energy and then back to mechanical energy to drive wheels.

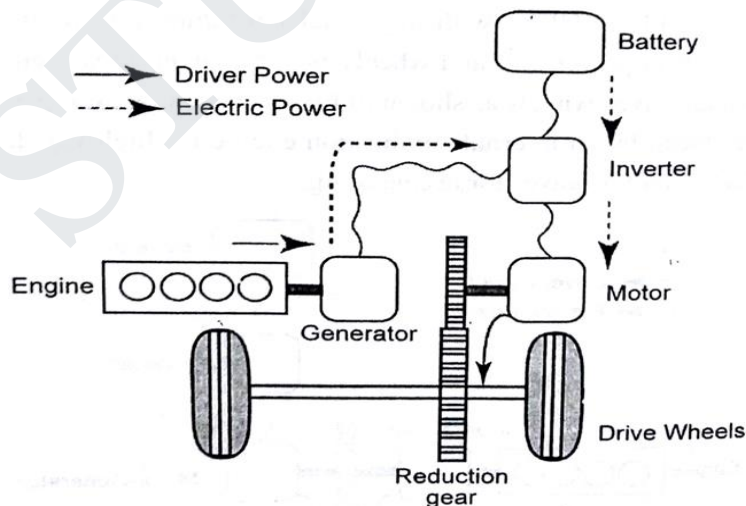

There are some benefits of a series configuration as follows:

1. The engine never idles which reduces vehicle emissions.
2. The engine can be continuously operated in its most efficient region.
3. The engine drives a generator to run at optimum performance.
4. The design allows for a variety of options when mounting engine and vehicle components.
5. Some series hybrids do not need a transmission.

USE OF FUEL CELLS IN AUTOMOBILES

A fuel cell produces electricity directly from the reaction between hydrogen (derived from a hydrogen-containing fuel or produced from the electrolysis of water) and oxygen from air. Like an internal combustion engine in a conventional car, it turns fuel into power by causing it to release energy. In an internal combustion engine, the fuel burns in tiny explosions that push the pistons up and down. When the fuel burns, it is being oxidized. In other words, the fuel combines oxygen and it produces energy in the form of heat and mechanical motion. In a fuel cell, the fuel is also oxidized but the resulting energy takes in the form of electricity. When powered by pure hydrogen, by-products of the reaction are heat and water.

A fuel cell power system has many components but its heart is the fuel cell stack which is made of many thin flat cells layered together. (Although the term *fuel cell* is often used to describe the entire stack strictly speaking, it refers only the individual cells.) Each cell produces electricity and output of all cells is combined to power the vehicle. Fuel cells have the potential to revolutionize the way we power our nation, offering cleaner, more-efficient alternatives to the combustion of gasoline and other fossil fuels.

The amount of power produced by a fuel cell depends on several factors including fuel cell type, cell size, the temperature at which it operates and the pressure at which the gases are supplied to the cell.

A single fuel cell produces enough electricity for only small applications. Therefore, to provide the power needed for most applications, individual fuel cells are combined in series into a fuel cell stack. A typical fuel cell stack may consist of hundreds of fuel cells.

Working Principle of a Fuel Cell

A fuel cell is an electrochemical device in which the chemical energy of a conventional fuel is directly converted into low voltage DC electrical energy. One of the main advantages of such device is that Carnot limitation on efficiency does not apply because the conversion can be carried out isothermally. A fuel cell is frequently described as a primary battery in which the fuel and oxidizer are stored in the battery and fed to it as needed.

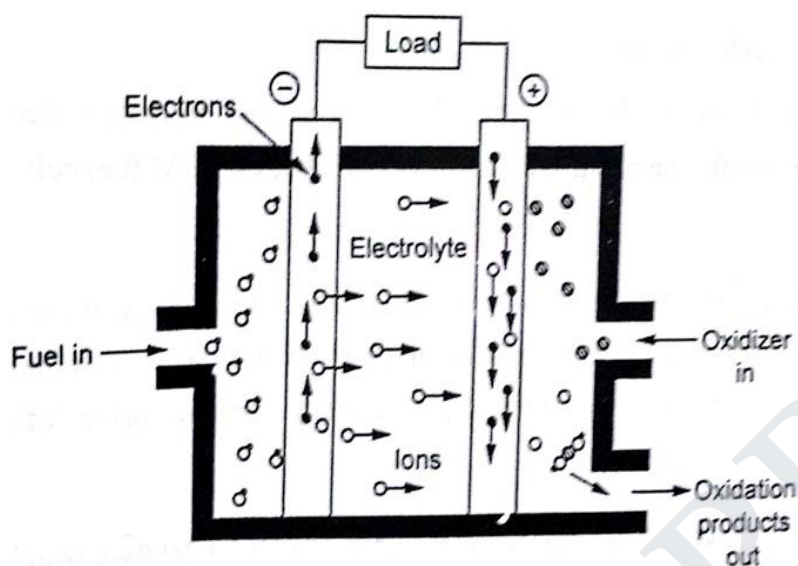

Figure shows a schematic diagram of a fuel cell. The fuel gas diffuses through the anode and it is oxidized. Therefore, it releases electrons to the external circuit. The oxidized fuel diffuses through the cathode and it is reduced by electrons coming from anode by the way of external circuit.

Parts of a Fuel Cell

Polymer Electrolyte Membrane (PEM) fuel cells are the current focus of research for fuel cell vehicle applications. PEM fuel cells are made from several layers of different materials as shown in the Figure. The three key layers in a PEM fuel cell include the following:

- Membrane electrode assembly
- Catalyst
- Hardware.

Types of Fuel Cells

Fuel cells are classified on the basis of electrolyte used. It determines the type of chemical reactions that take place in the cell, kind of catalysts required, temperature range in which the cell operates, fuel required and other factors. These characteristics in turn affect the applications for which these cells are most suitable. There are several types of fuel cells currently under development, each with its own advantages, limitations and potential applications.

1. Hydrogen-oxygen fuel cell
2. Polymer Electrolyte Membrane (PEM) fuel cell
3. Direct methanol fuel cell
4. Alkaline fuel cell

5. Phosphoric acid fuel cell
6. Molten carbonate fuel cell
7. Solid oxide fuel cell
8. Regenerative fuel cell.

STUCOR APP